



Operation Manual

Product name:

Pulse Blow Valve

Model/ Series/ Product Number

AXTS040*-2,3(B)-X2

SMC Corporation

Contents

Safety Instructions	• • • P	3,4
1. Specifications	• • • P	5
2. Port size and flow characteristics	• • • P	5
3. How to Order	• • • P	5
4. Configuration symbol	• • • P	6
5. Piping method	• • • P	7,8
6. Frequency adjustment	• • • P	9,10
7. Mounting	• • • P	11
8. Environment	• • • P	11
9. Lubricant oil	• • • P	11
10. Air source	• • • P	11



Safety Instructions

These safety instructions are intended to prevent hazardous situations and/or equipment damage. These instructions indicate the level of potential hazard with the labels of "Caution", "Warning" or "Danger". They are all important notes for safety and must be followed in addition to International Standards (ISO/IEC)^{*1)} and other safety regulations.

*1) ISO 4414: Pneumatic fluid power -- General rules relating to systems

ISO 4413: Hydraulic fluid power -- General rules relating to systems

IEC 60204-1: Safety of machinery -- Electrical equipment of machines (Part 1: General requirements) General requirements) General requirements)

ISO 10218-1992: Manipulating industrial robots-Safety



Caution

CAUTION indicates a hazard with a low level of risk which, if not avoided, could result in minor or moderate injury.

Warning

WARNING indicates a hazard with a medium level of risk which, if not avoided, could result in death or serious injury.

Danger

Danger indicates a hazard with a high level of risk which, if not avoided, could result in death or serious injury.

Warning

1. The compatibility of the product is the responsibility of the person who designs the equipment or decides its specifications.

Since the product specified here is used under various operating conditions, its compatibility with specific equipment must be decided by the person who designs the equipment or decides its specifications based on necessary analysis and test results.

The expected performance and safety assurance of the equipment will be the responsibility of the person who has determined its compatibility with the product.

This person should also continuously review all specifications of the product referring to its latest catalog information, with a view to giving due consideration to any possibility of equipment failure when configuring the equipment.

2. Only personnel with appropriate training should operate machinery and equipment.

The product specified here may become unsafe if handled incorrectly.

The assembly, operation and maintenance of machines or equipment including our products must be performed by an operator who is appropriately trained and experienced.

3. Do not service or attempt to remove product and machinery/equipment until safety is confirmed.

1. The inspection and maintenance of machinery/equipment should only be performed after measures to prevent falling or runaway of the driven objects have been confirmed.

2. When the product is to be removed, confirm that the safety measures as mentioned above are implemented and the power from any appropriate source is cut, and read and understand the specific product precautions of all relevant products carefully.

3. Before machinery/equipment is restarted, take measures to prevent unexpected operation and malfunction.

4. Contact SMC beforehand and take special consideration of safety measures if the product is to be used in any of the following conditions.

1. Conditions and environments outside of the given specifications, or use outdoors or in a place exposed to direct sunlight.

2. Installation on equipment in conjunction with atomic energy, railways, air navigation, space, shipping, vehicles, military, medical treatment, combustion and recreation, or equipment in contact with food and beverages, emergency stop circuits, clutch and brake circuits in press applications, safety equipment or other applications unsuitable for the standard specifications described in the product catalog.

3. An application which could have negative effects on people, property, or animals requiring special safety analysis.

4. Use in an interlock circuit, which requires the provision of double interlock for possible failure by using a mechanical protective function, and periodical checks to confirm proper operation. Inspect the product periodically to confirm proper operation.



Safety Instructions

Caution

The product is provided for use in manufacturing industries.

The product herein described is basically provided for peaceful use in manufacturing industries. If considering using the product in other industries, consult SMC beforehand and exchange specifications or a contract if necessary. If anything is unclear, contact your nearest sales branch.

Limited Warranty and Disclaimer/ Compliance Requirements

The product used is subject to the following “Limited warranty and Disclaimer” and “Compliance Requirements”.

Read and accept them before using the product.

Limited Warranty and Disclaimer

- ① **The warranty period of the product is 1 year in service or 1.5 years after the product is delivered, whichever is first.
Also, the product may have specified durability, running distance or replacement parts. Please consult your nearest sales branch.**
- ② **For any failure or damage reported within the warranty period which is clearly our responsibility, a replacement product or necessary parts will be provided.
This limited warranty applies only to our product independently, and not to any other damage incurred due to the failure of the product.**
- ③ **Prior to using SMC products, please read and understand the warranty terms and disclaimers noted in the specified catalog for the particular products.**

Compliance Requirements

1. The use of SMC products with production equipment for the manufacture of weapons of mass destruction(WMD) or any other weapon is strictly prohibited.
2. The exports of SMC products or technology from one country to another are governed by the relevant security laws and regulation of the countries involved in the transaction. Prior to the shipment of a SMC product to another country, assure that all local rules governing that export are known and followed.

1. Specifications

Valve construction	Metal seal
Fluid	Air
Max. operating pressure	1.0MPa
External pilot air pressure	0.2 to 1.0MPa (External pilot type)
Frequency adjustment range	1 to 5Hz (internal pilot type)
	1 to 8Hz (external pilot type)
Proof pressure	1.5MPa
Ambient and fluid temperature	-20 to +60 °C
Lubrication	No
Enclosure rating	IP65 equivalent
Weight	About 1,400g

※Use an External pilot pressure higher than IN port pressure.

2. Port size

Body port	Flow characteristics					
	Internal pilot type 1(P)⇒4(A)			External pilot type 3(R2)⇒2(B)		
	C [dm ³ /(s · bar)]	B	Cv	C [dm ³ /(s · bar)]	B	Cv
1/2	12	0.14	2.9	14	0.18	3.4

※This is the flow rate when the main valve is fully open.

3. How to order

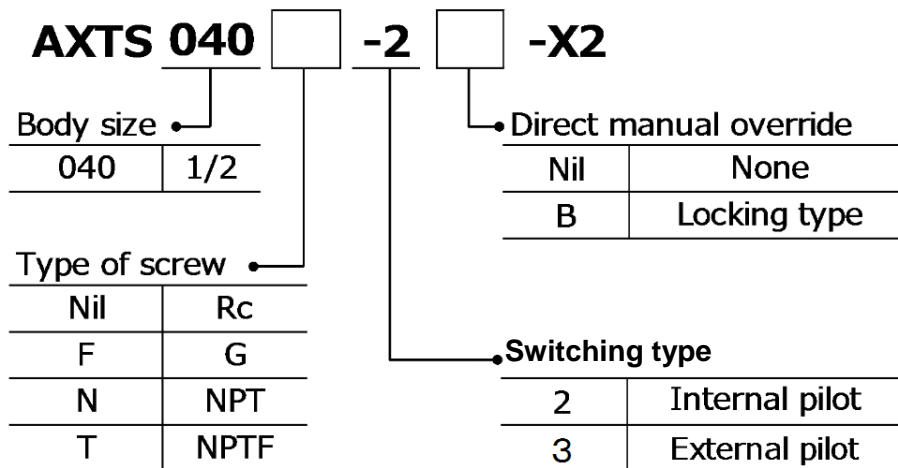

4. Configuration symbol

AXTS040*-2(B)-X2 Symbol for internal pilot fluid passage

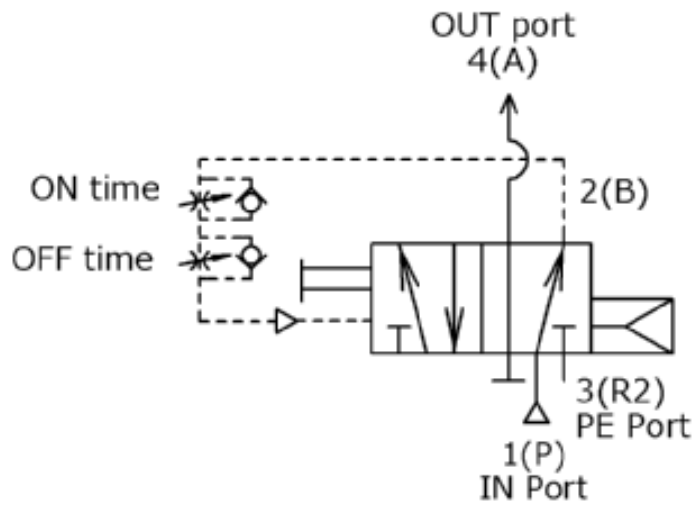

Fig.1 Symbol for internal pilot fluid passage.

- 1(P) Port:IN Port SUP.Air(for air blow)
- 4(A) Port:OUT Port
- 3(R2) Port: Released to atmosphere (pilot exhaust port with silencer)

AXTS040*-3(B)-X2 Symbol for internal pilot fluid passage

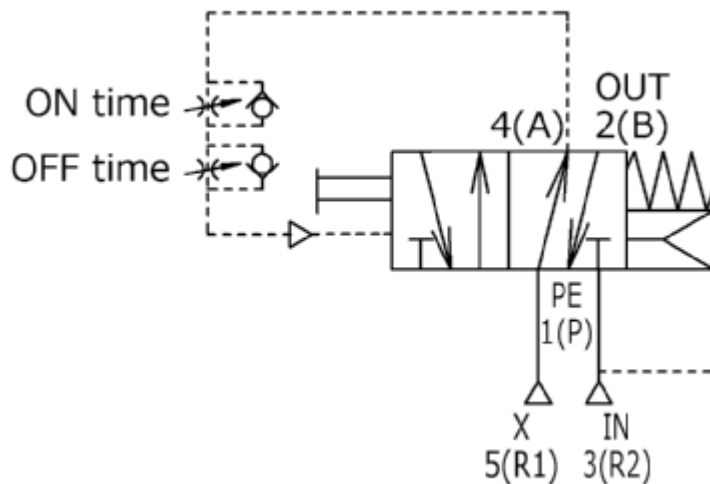

Fig.2 Symbol for external pilot fluid passage.

- 3(R2) port: IN Port SUP. air (for air blow)
- 2(B) port: OUT port
- 5(R1) port: External pilot air
- 1(P) port: Released to atmosphere (pilot exhaust port with silencer)

5. Piping

AXTS040*-2(B)-X2

Symbol for internal pilot fluid passage

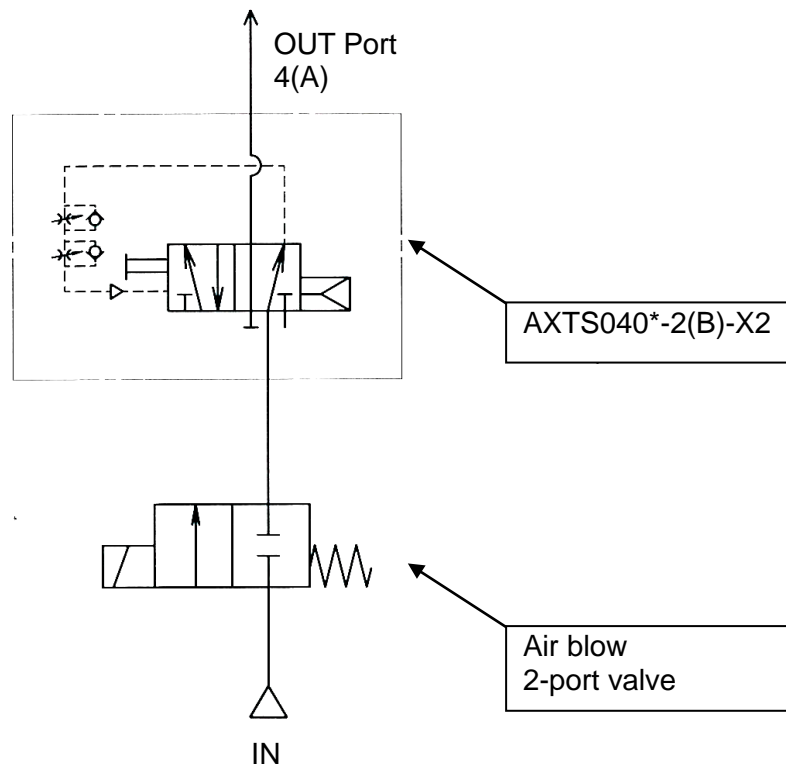

Fig.3 Symbol for internal pilot fluid passage.

Caution

- Continuous blow air can be changed to pulse air without electrical wiring by connecting the pulse blow valve between air blow 2 port valve and nozzle of existing equipment.
- When an air gun and a pressure regulator are connected to OUT port, the back pressure of the OUT port will be high. Therefore, the product cannot be used.
- When a vacuum ejector and a suction filter are connected to the OUT port, the back pressure of the OUT port will be higher due to the clogging of the filter and silencer of the vacuum ejector during operation. Therefore, the product cannot be used. In that case, please use the external pilot type to avoid the influence of the back pressure.
- Keep using the plug and port with silencer.
- Direct manual override is operated by flat blade screwdriver. Insert the flat blade driver to the groove until it contacts the bottom of the groove and turn the driver 90 degrees. Rotating direction does not matter. Do the same for release (push and rotate for 90 degrees).
- Tighten the piping using the correct torque shown below.

Table.1

Thread	Appropriate tightening torque (Nm)
1/2	20 to 25

AXTS040*-3(B)-X2 External pilot type

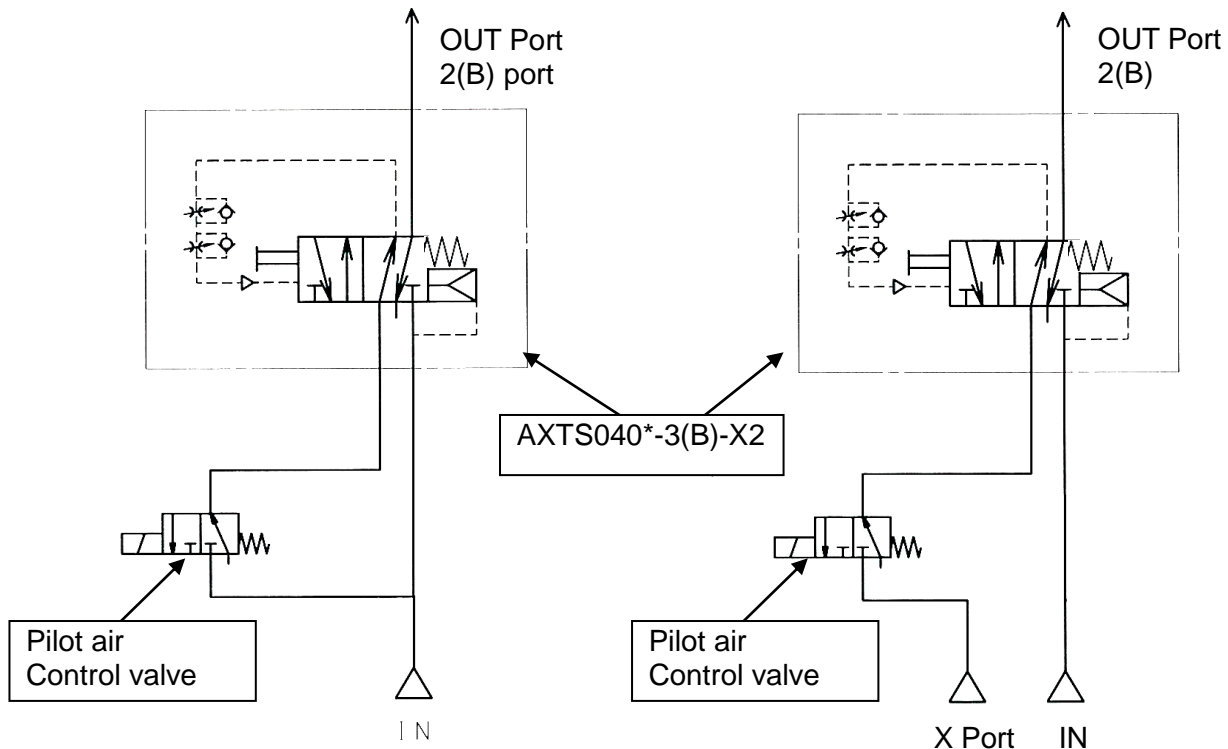

Fig.4 Piping for External pilot fluid passage 1

Fig.5 Piping for External pilot fluid passage 2

Caution

- The description of the sub plate and piping port do not match. Be careful with the piping port.
- For external pilot type, pulse air is only generated while pilot air is supplied. The blow is constantly stopped by the return spring when the pilot air is not supplied. Air may leak from the main valve as this is metal seal type. (Refer to Fig.4)
- When the minimum operating pressure or more is supplied to the X port, air pulse is generated even when IN port is pressure is less than the minimum operating pressure (Refer to Fig.4).
- When the IN port pressure constantly exceeds the minimum operating pressure, the same air can be connected to the IN port and X port (Refer to Fig.5).
- When the product is used in a condition where the OUT port back pressure varies, for example, vacuum ejector and / or suction filter is connected to the OUT port, please consider that the operation frequency will be changed.
- Keep using the plug and port with silencer.
- Direct manual override is operated by flat blade screwdriver. Insert the flat blade driver to the groove until it contacts the bottom of the groove and turn the driver 90 degrees. Rotating direction does not matter. Do the same for release (push and rotate for 90 degrees).
- Tighten the piping using the correct torque shown below.
- Use an External pilot pressure higher than IN port pressure.

Table.2

Thread	Appropriate tightening torque (Nm)
1/2	20 to 25

6. Frequency adjustment

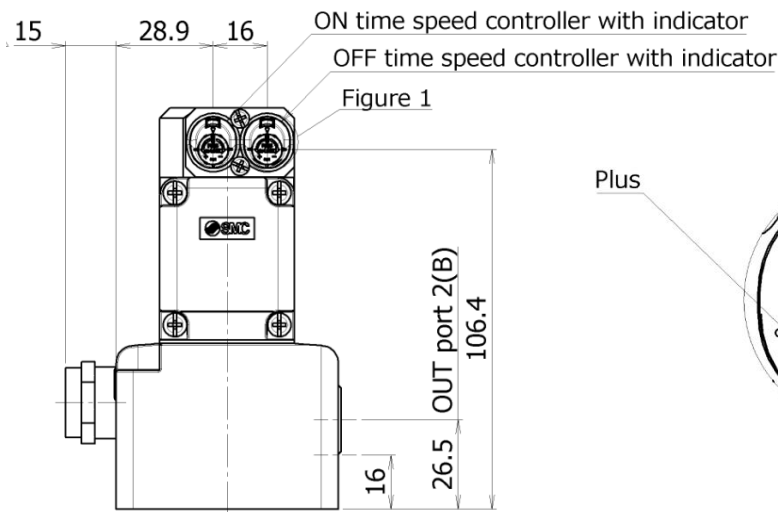

Fig.6 Adjustment needle

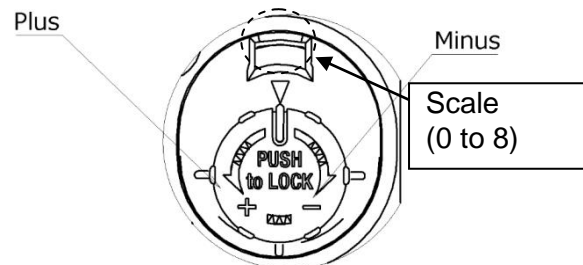

Fig.7 Adjustment needle Expansion

Caution

- ON time is shortened by rotating the ON time adjustment needle counterclockwise.
- OFF time is shortened by rotating the OFF time adjustment needle counterclockwise.
- Refer to the scale as a guideline for resetting. ON time ratio does not become 50% even when setting the adjustment needle for ON and OFF at the same value.
- Small amount of leakage exists even when the needle is fully close. Do not use the adjustment needle for the stopping of operation.
- When one needle is adjusted, the time for the opposite side will be slightly changed.
- Internal pilot: 1 to 5HZ and external pilot: 1 to 8Hz is reference.
- The charts on page 10 show the relation for the adjustment needle value and operation frequency. However, there is approx. 2Hz of variation depending on individuality.
- Operating conditions affect the operating frequency.
 - Except for the adjustment needle, conditions below affect the operating frequency.
 - (1) Bore size and piping length (upstream and downstream)
 - (2) Supply pressure (the higher, the faster)
 - (3) Nozzle (The smaller of the exhaust port, the faster)
- Blow air may not become pulse air depending on the volume of the downstream. Keep the product close to the nozzle as much as possible. (Guideline 1m)

Relation between the adjustment needle scale and operation frequency

AXTS040*-2(B)-X2 Internal pilot type

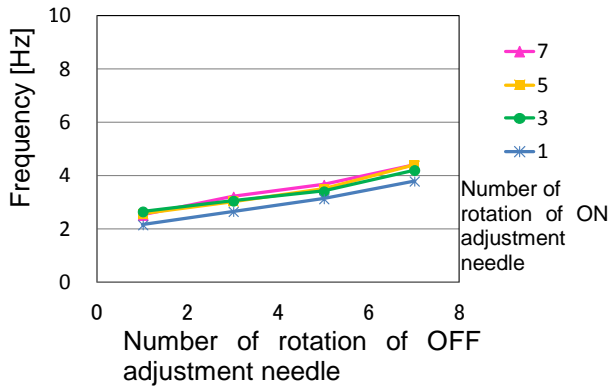

AXTS040*-2B-X2 Internal pilot valve
Ratio of operating frequency and ON time

		OFF adjustment			
		1	3	5	7
ON adjustment [Rotation]	1	2.1 Hz 31%	2.6 Hz 64%	3.1 Hz 74%	3.8 Hz 73%
	3	2.6 Hz 19%	3.0 Hz 60%	3.4 Hz 72%	4.2 Hz 71%
	5	2.6 Hz 21%	3.0 Hz 61%	3.5 Hz 70%	4.4 Hz 67%
	7	2.5 Hz 24%	3.2 Hz 58%	3.6 Hz 69%	4.4 Hz 67%

※ At an inlet pressure of 0.3MPa.

AXTS040*-3(B)-X2 External pilot type

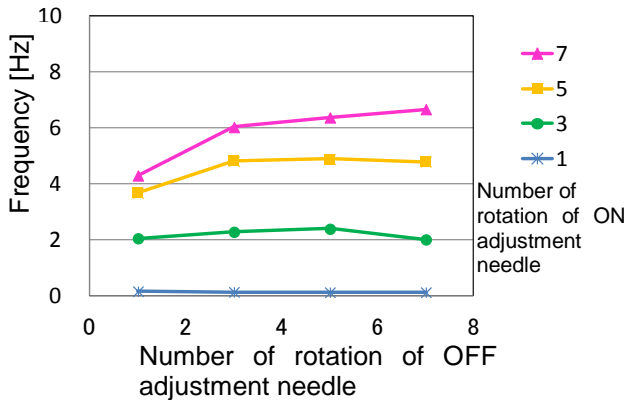

AXTS040*-3B-X2 External pilot valve
Ratio of operating frequency and ON time

		OFF adjustment			
		1	3	5	7
ON adjustment [Rotation]	1	0.1 Hz 2%	0.1 Hz 2%	0.1 Hz 1%	0.1 Hz 1%
	3	2.0 Hz 29%	2.3 Hz 17%	2.4 Hz 15%	2.0 Hz 14%
	5	3.7 Hz 51%	4.8 Hz 36%	4.9 Hz 32%	4.8 Hz 24%
	7	4.3 Hz 58%	6.0 Hz 43%	6.4 Hz 40%	6.7 Hz 32%

※ When both pressure X port and P port are 0.3MPa.

7. Mounting

Before connecting the valve, flush the piping of the upstream (supply pressure port side) and downstream (control equipment port side) to eliminate particles in the piping and foreign matter and scales generated during piping.

8. Environment

Please contact SMC if the product is used where corrosive gas, chemicals and their solutions, water vapor, or seawater droplets exist, or temperature exceeds 50°C, or vibration occurs.

9. Lubricant oil

The product has been lubricated for life by the manufacturer, and does not require lubrication in service.

10. Air Source

- ① Install an air filter of 5 μ m to the upstream of the solenoid valve (air source side). Install the filter as close to the valve as possible. Air resistance is large and the flow decreases when the filter element is clogged. Clean the filter element.
- ② Carbon powder and oil depleting materials generated from the air supply (mainly from the compressor) can cause an increase in friction on the spool causing it to stick. This may result in the valve failing to operate. If the supply pressure is pressurized for a long time with low quality air, then carbon powder or oil depleting materials contained in the compressed air might accumulate in the space between the spool and sleeve, which may cause the spool to stick. In this situation, the type of the compressor lubricating oil should be replaced with a good quality compressor lubrication oil that generates less oxidants. It is possible to prevent fine foreign matter from entering the valve by mounting a mist separator with high filtration accuracy (AM series) after a normal filter (AF series). If the product is used for extended period of time where a large amount of oil depleting materials exist, the cartridge element will be clogged and pressure drop becomes large. When the differential pressure reaches 0.1MPa or more, or the product is used more than a year, replace the cartridge element. Replace the element at least within 3 years of use.
- ③ If the product is used with the filter case fully accumulated with drain, it may enter into the downstream, causing operation failure of the valve. Discharge drain regularly. Cycle time for drain discharge is different depending on the weather and air consumption. The piping should be slightly sloped so that generated drain is pooled in one place with the drain cock for discharge to the outside. The slope for the piping should be 1:100.

Refer to "SMC Air Preparation System" for further details on air source. For details of filter, mist separator and regulator, refer to the operation manual for each parts.
AF series for the filter, AM series for the mist separator, and AR series for the regulator.

Revision history
A : Modify items in graph

SMC Corporation

4-14-1, Sotokanda, Chiyoda-ku, Tokyo 101-0021 JAPAN

Tel: + 81 3 5207 8249 Fax: +81 3 5298 5362

URL <https://www.smcworld.com>

This manual is subject to change without prior notice.
© 2020 SMC Corporation All Rights Reserved