

4 Ways of Connection

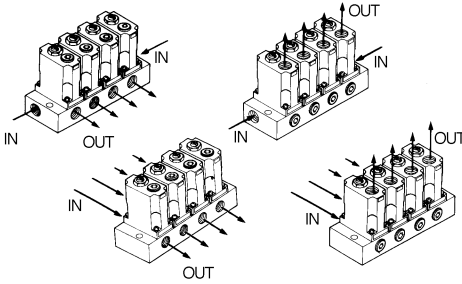

Small Size Pressure Gauge
ø15mm
Reverse flow function available
on the standard model

Space Saving



NARM1000-6A1-N01G

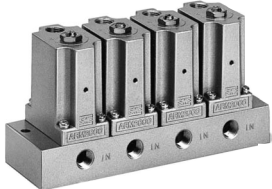

NARM2000-4B2

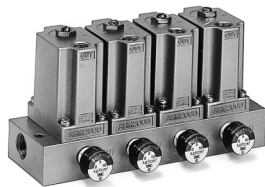

NARM2000-4A2-N01G

Symbol

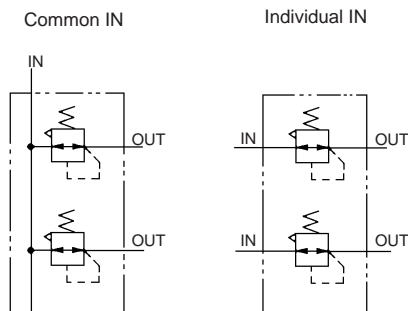

Standard Specifications

Fluid	Air
Proof pressure psig (MPa)	175 (1.2)
Max. operating pressure psig (MPa)	120 (0.8)
Set pressure range psig (MPa)	7~100 (0.05 to 0.7)
Ambient and fluid temperature	23°~140°F (-5 to 60°C) (No freezing)
Fluid	Air
Cracking pressure (Valve) psig (MPa)	3 (0.02)
Construction	Relief style

Port size/Weight

Model	Porting	Port size		Weight lb (g)	
		IN	OUT	Total weight (n: stations)	Regulator (Except manifold)
NARM1000	Common IN	1/8	1/8	(80 X n) + 23	.13 (57)
	Individual IN	1/8	1/8	(79 X n) + 25	
NARM2000	Common IN	1/4	1/8	(188 X n) + 43	.3 (136)
	Individual IN	1/8	1/8	(187 X n) + 45	

How to Order

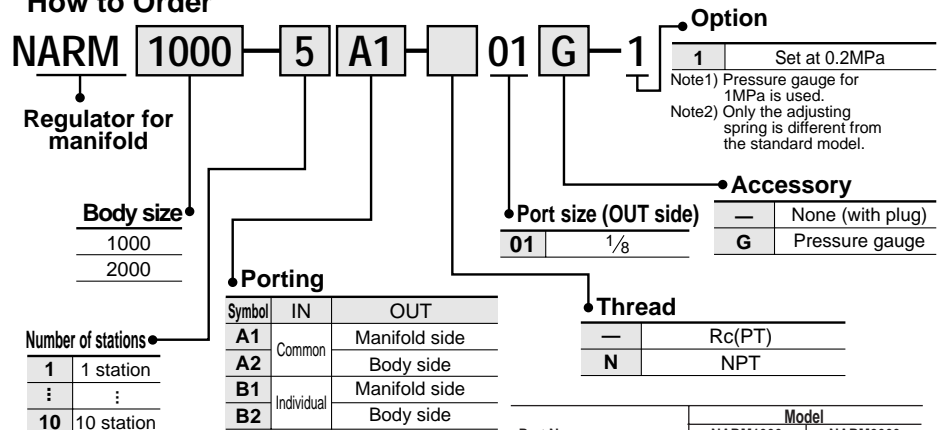

Note1) In case of A1 and B1, a pressure gauge or a plug is mounted at the body side, while in case of A2 and B2, at the manifold side.
Note2) Pressure gauges mounted in body are oriented so that the 6 o'clock position of the gauge is at the pressure adjusting screw.

Part Name	Model	
	NARM1000	NARM2000
Regulator w/o mflid	NARM1000A	NARM2000A
Pressure gauge	G15-P10-N01	G15-P10-N01
Blanking plate kit (plate, screws, and o-ring)	136114A	136214A
Manifold base, Common IN (A1, A2)	13612 ^{-*} -N	13622 ^{-*} -N
Manifold base, Individual IN (B1, B2)	13613 ^{-*} -N	13623 ^{-*} -N

* Denotes number of stations: 2-10 available.

Option: Pressure gauge G15-10-01

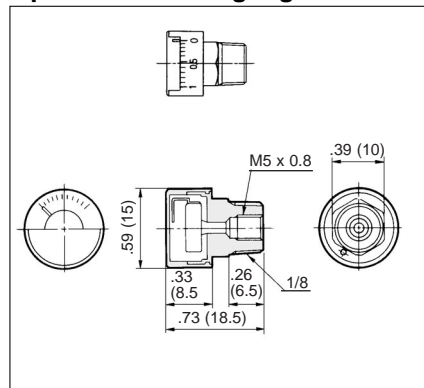

•Precautions:

How to Order

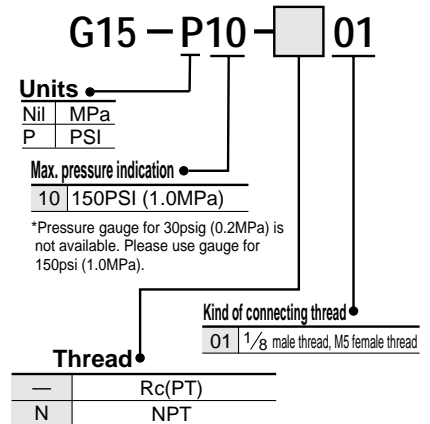

Regulator for Manifold
NARM1000, 2000

Construction (Individual IN)

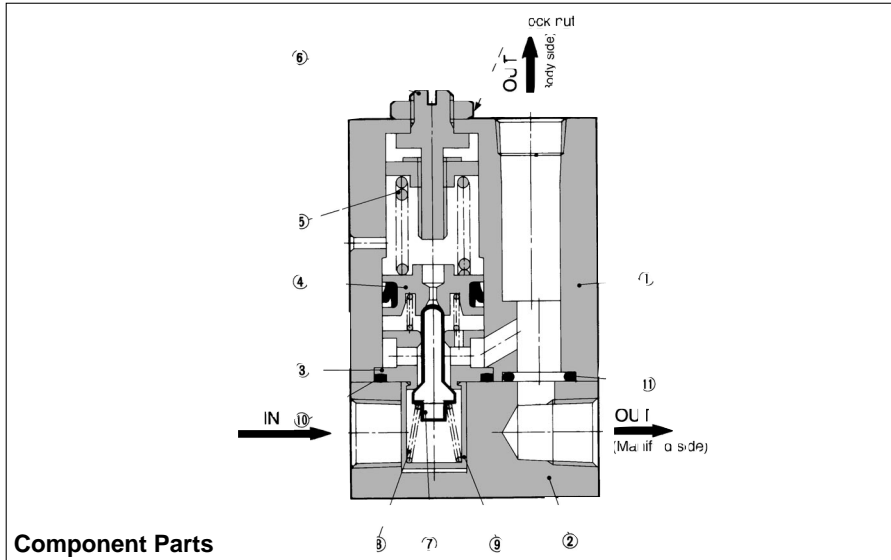

Component Parts

No.	Description	Material	Note
①	Body	ADC	Chromate
②	Manifold	Aluminum alloy	Chromate
③	Valve guide	Brass	
④	Piston	Brass	
⑤	Adjusting spring	Steel wire	Zinc chromate
⑥	Adjusting screw	Steel	Electroless nickel plating

Replacement Parts

No.	Description	Material	Part no.	
			NARM1000	NARM2000
⑦	Valve	Brass/NBR	134819	13626
⑧	Valve spring	Stainless steel	13615	13625
⑨	Valve retainer	POM	13614	13624
⑩	O-ring	NBR	16.5 x 13.5 x 1.5	23 x 20 x 1.5
⑪	O-ring	NBR	P7	P8

Setting

- Make sure to check the primary pressure before setting the secondary pressure. Turning the pressure adjustment handle clockwise increases the secondary pressure and turning it counterclockwise decreases the pressure. (To set the pressure, do so in the direction of pressure increase.)
- The secondary pressure must be set to 85% or less of the primary pressure.

⚠️ Precautions

Be sure to read before handling.
Refer to page 6 for Safety Instructions and precautions common to the products mentioned in this volume and refer to pages 7 and 8 for more detailed precautions of every series.

Mounting/Adjustment

⚠️ Warning

- In the case of the common IN type, supply pressure from the two IN ports from both ends. Failure to observe this procedure could lead to an excessive pressure drop.
- Set up the regulator while verifying the pressure that is indicated on the primary and the secondary pressure gauges. Turning the handle excessively could damage the internal parts.

⚠️ Caution

- Release the lock to adjust the pressure. After the adjustment, engage the lock. Failure to observe this procedure could damage the handle or cause the secondary pressure to fluctuate.

Maintenance

⚠️ Warning

- Make sure to perform a periodic inspection of the pressure gauge when it is used by installing it between a solenoid valve and an actuator, etc. Because of the possibility of creating sudden pressure fluctuations, the durability of the product could be shortened.
Under certain circumstances, the use of an electronic type pressure gauge is recommended.

Flow Characteristics

NARM1000 Supply pressure: 100 psig

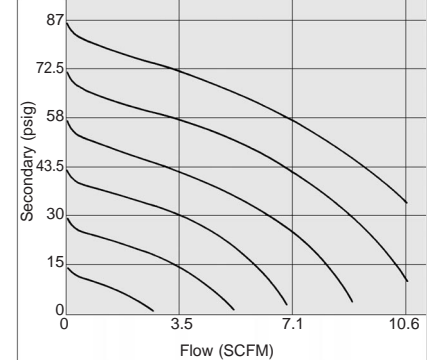

NARM2000

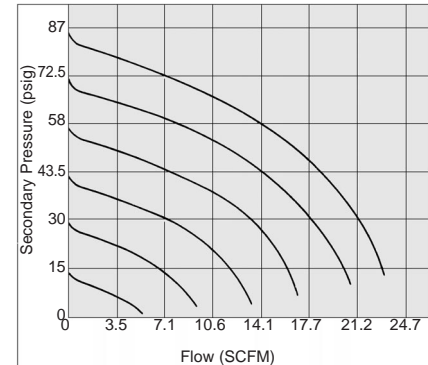

Pressure Characteristics

Initial setting Supply pressure: 0.7MPa(7.1kgf/cm²)
Secondary pressure: 0.2MPa(2.0kgf/c
Flow: .4 SCFM

NARM1000

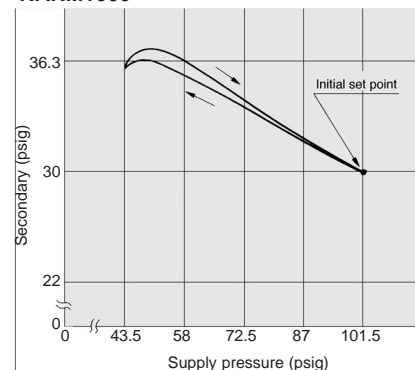

NARM2000

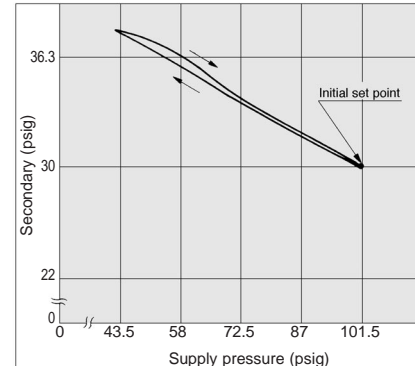

Dimensions

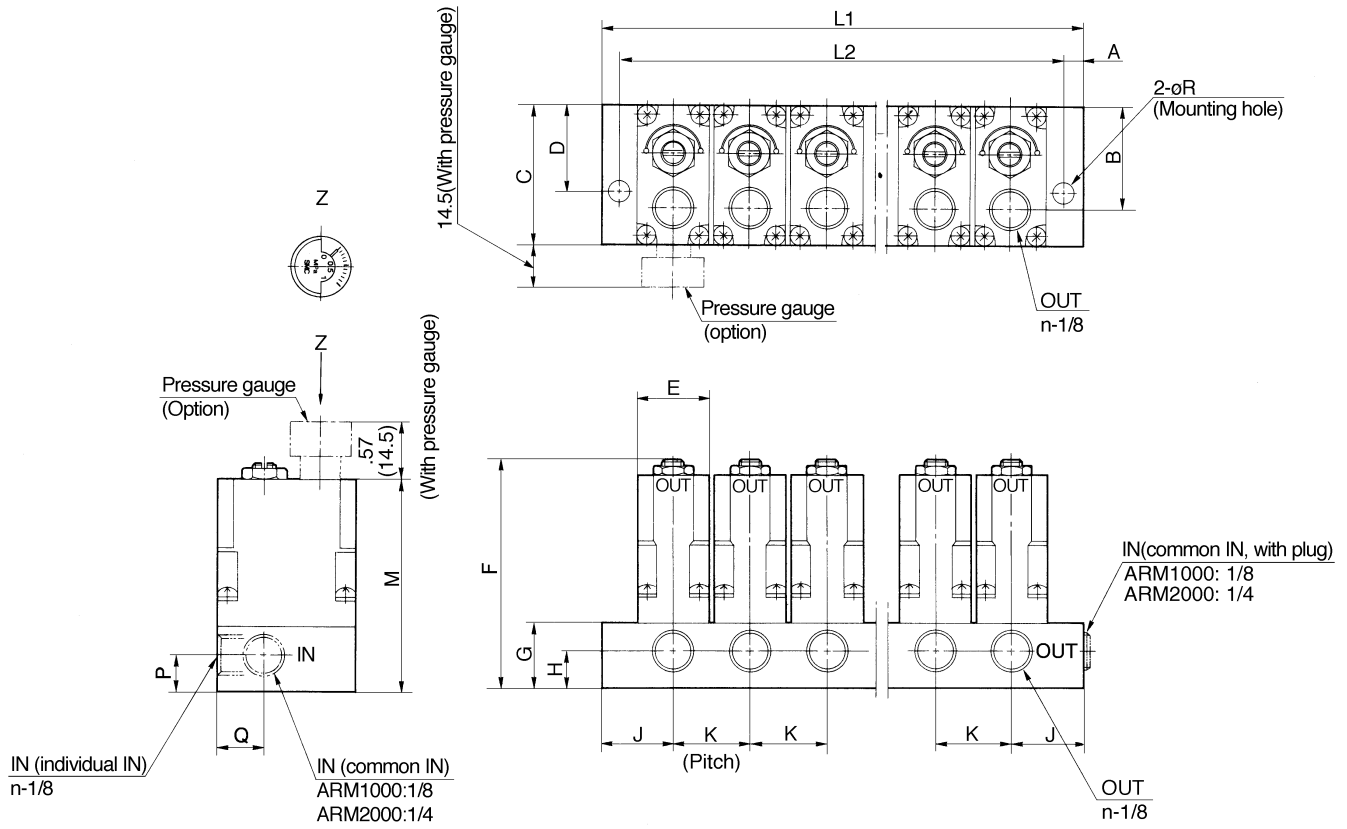

Dimensions

Model	Symbol	A	B	C	D	E	F	G	H	J	K	M	P	Q	R
NARM1000		.18	.98	1.34	.83	.71	2.20	.63	.35	.71	.75	2.05	.35	.45	.19
		(4.5)	(25)	(34)	(21)	(18)	(56)	(16)	(9)	(18)	(19)	(52)	(9)	(11.5)	(4.8)
NARM2000		.18	1.36	1.69	1.10	1.06	2.76	.79	.45	.94	1.10	2.60	.45	.65	.19
		(4.5)	(34.5)	(43)	(28)	(27)	(70)	(20)	(11.5)	(24)	(28)	(66)	(11.5)	(16.5)	(4.8)

Dimensions by number of stations

Model	Symbol	A	C	E	F	G	H	J	K	M	P
NARM1000	L1	1.42 (36)	2.17 (55)	2.91 (74)	3.66 (93)	4.41 (112)	5.16 (131)	5.91 (150)	6.65 (169)	7.40 (188)	8.15 (207)
	L2	1.06 (27)	1.81 (46)	2.56 (65)	3.31 (84)	4.06 (103)	4.80 (122)	5.55 (141)	6.30 (160)	7.05 (179)	7.80 (198)
NARM2000	L1	1.89 (48)	2.99 (76)	4.09 (104)	5.20 (132)	6.30 (160)	7.40 (188)	8.50 (216)	9.61 (244)	10.71 (272)	11.81 (300)
	L2	1.54 (39)	2.64 (67)	3.74 (95)	4.84 (123)	5.94 (151)	7.05 (179)	8.15 (207)	9.25 (235)	10.35 (263)	11.46 (291)

Regulator for Manifold
NARM2500, 3000

A modular type that can easily be mounted in a manifold station.

Optimal for central pressure control.

Pressure easily set using the new handle.
One-touch lock system.



NARM3000



NARM2500

How to Order

NARM **2500** **05** **A** **02** **G1**

Regulator for manifold

Body size

2500
3000

Number of stations

02	2 stations
⋮	⋮
10	10 stations

Accessory

—	None (with plug)
G1	K40A-MP1.0-N01M
G2	K40A-MP1.0-N01M

Port size (OUT side)

Symbol	Port size	Applicable model
02	NPT 1/4	NARM2500
03	NPT 3/8	NARM3000

Piping

Symbol	Type	IN
A	Common IN	From end plate
B	Individual IN	Below: OUT port or G port

Standard Specifications

Proof pressure psig (MPa)	220 (1.5)
Max. operating pressure psig (MPa)	150 (1.0)
Set pressure range psig (MPa)	7~120 (0.05 to 0.85)
Ambient and fluid temperature	23~140 (-5 to 60°C) (No freezing)
Fluid	Air
Construction	Relief type

Port size/Weight

Model	Piping	Port size NPT			Pressure gauge port size NPT	Weight lb (kg)	
		IN		OUT		Regulator	End plate
		Body	End plate				
NARM2500	Common IN	—	3/8	1/4	1/8	.57 (0.26)	.13 (0.06)
	Individual IN	1/4	—	1/4	1/8		
NARM3000	Common IN	—	1/2	3/8	1/8	1.04 (0.47)	.24 (0.11)
	Individual IN	3/8	—	3/8	1/8		

Symbol

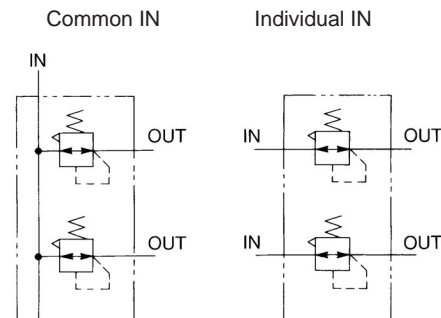

Weight by number of stations

Model	Stations	2	3	4	5	6	7	8	9	10
NARM2500	lb (kg)	1.50 (0.68)	2.12 (0.96)	2.71 (1.23)	3.33 (1.51)	3.92 (1.78)	4.54 (2.06)	5.14 (2.33)	5.75 (2.61)	6.37 (2.89)
NARM3000	lb (kg)	2.67 (1.25)	3.86 (1.75)	4.96 (2.25)	6.06 (2.75)	7.19 (3.26)	8.29 (3.76)	9.39 (4.26)	10.49 (4.76)	11.6 (5.26)

Option: Mounting bolt ass'y

Model	Part no.	Dimensions	Qty.	Note
NARM2500	136313	Hexagon socket head cap screw (M5 x 70)	4	With flat washer
NARM3000	136413	Hexagon socket head cap screw (M6 x 85)	4	With flat washer

Option: Bracket assembly

Individual IN type can be used as a single regulator.

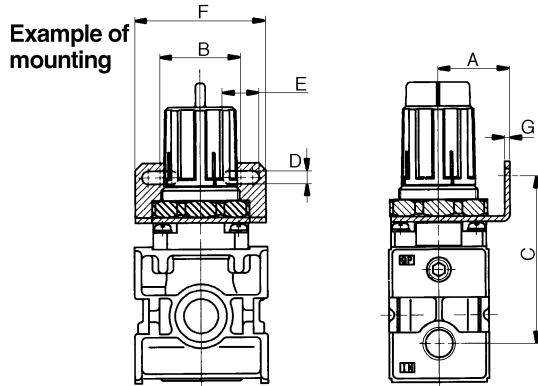

Model	Part no.	A	B	C	D	E	F	G
NARM2500	136314	1.18 (30)	1.34 (34)	2.76 (70)	.21 (5.4)	.61 (15.4)	2.17 (55)	.09 (2.3)
NARM3000	136414	1.61 (41)	1.57 (40)	2.97 (75.5)	.26 (6.5)	.31 (8)	2.09 (53)	.09 (2.3)

⚠️ Precautions

Be sure to read before handling.

Refer to page 6 for Safety Instructions and precautions common to the products mentioned in this volume and refer to pages 7 and 8 for more detailed precautions of every series.

Mounting/Adjustment

⚠️ Warning

- ① The adjustment handle must be operated manually. Using a tool to turn the handle could lead to damage.
- ② Set up the regulator while verifying the pressure that is indicated on the primary and the secondary pressure gauges. Turning the handle excessively could damage the internal parts.

⚠️ Caution

- ① Release the lock to adjust the pressure. After the adjustment, engage the lock. Failure to observe this procedure could damage the handle or cause the secondary pressure to fluctuate.
 - 1) On the NARM2500, pull the adjustment handle to release the lock and push the adjustment handle to engage the lock. If it does not lock easily, turn the handle slightly clockwise or counterclockwise before pushing it.

- 2) On the NARM3000, pull the adjustment handle to release the lock. (An orange colored line is provided at the bottom of the adjustment handle for visual checking.) Push the adjustment handle to engage the lock. If it does not lock easily, turn the handle slightly clockwise or counterclockwise; then, push it until the orange colored line is no longer visible.
- ② Turning the pressure adjustment handle clockwise increases the secondary pressure and turning it counterclockwise decreases the pressure.
- ③ Make sure to check the primary pressure before setting the pressure. The secondary pressure must be set to 85% or less of the primary pressure. Failure to observe this procedure could cause the secondary pressure to fluctuate.
- ④ In the case of the common IN type, supply pressure from the two IN ports from both ends. Failure to observe this procedure could lead to an excessive pressure drop.

Flow Characteristics Supply pressure: 100 psig

NARM2500

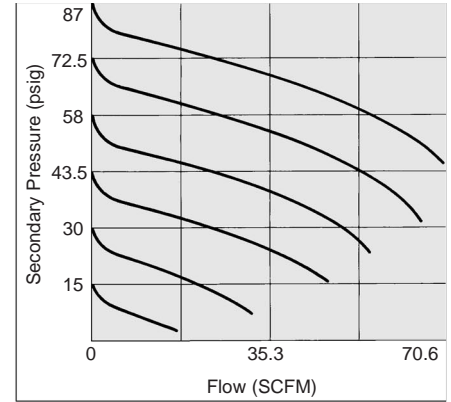

NARM3000

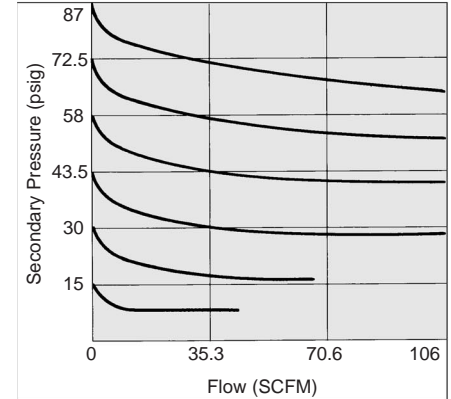

Supply pressure 100 psig
Secondary pressure 30 psig
Flow rate .7 SCFM

Pressure Characteristics

NARM2500

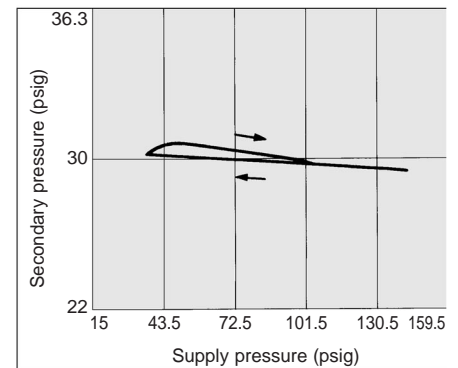

NARM3000

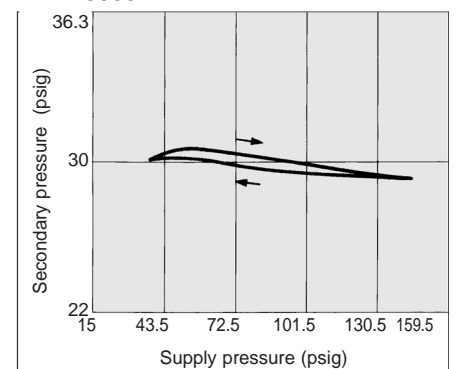

Regulator for Manifold
NARM2500, 3000

Construction

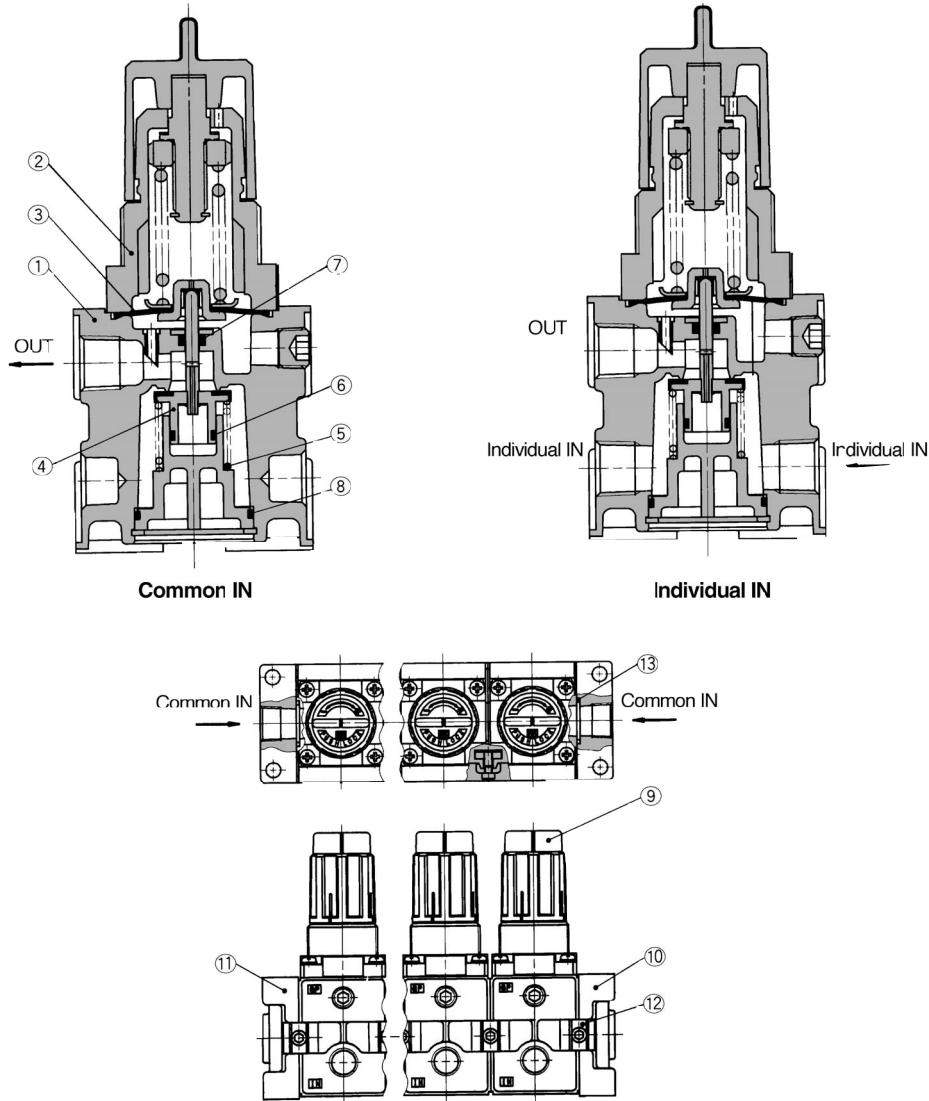

Main Parts

No.	Description	Material	Note
①	Body	Aluminum die casting	Chromate/Platinum silver painting
②	Bonnet	Polyacetal	

Component Parts

No.	Description	Material	Part no.	
			NARM2500	NARM3000
③	Diaphragm ass'y	NBR	1349161A	131515A
④	Valve ass'y	Brass/NBR	13639A	13649A
⑤	Valve spring	Stainless steel	136310	136410
⑥	Valve O-ring	NBR	11.5 X 8.5 X 1.5	14.5 X 10.5 X 2
⑦	O-ring	NBR	P3	P5
⑧	O-ring	NBR	28 X 25 X 1.5	35 X 31 X 2

Component Parts

Description	No.	Assembly		Part no.			
		Component	Qty.	NARM2500		NARM3000	
				Common IN	Individual IN	Common IN	Individual IN
Regulator	⑨	Regulator	1	NARM2500-A-N02	NARM2500-B-N02	NARM3000-A-N03	NARM3000-B-N03
End plate ass'y	⑩	End plate R	1	13636A	13636B (Except for O-ring)	13646A	13646B (Except for O-ring)
	⑪	End plate L	1				
	⑫	O-ring	1				
	⑬	Bracket Bracket A Bracket B Hexagon socket head cap screw	2 1 set 2 2				
Bracket ass'y	⑭	O-ring	1	136312	136412		
	⑮	Bracket A	2				
		Bracket B Hexagon socket head cap screw	1 set 2 2				

How to Order

(1) When adding n stations to ARM $\frac{2500}{3000} * A, B$

- Regulator n pcs.
- Bracket ass'y n pcs.

(2) When ordering regulators, end plate assembly and bracket assembly are assembled to make the manifold of n stations.

- Regulator n pcs.
- Bracket ass'y n pcs.
- End plate ass'y 1 pc.

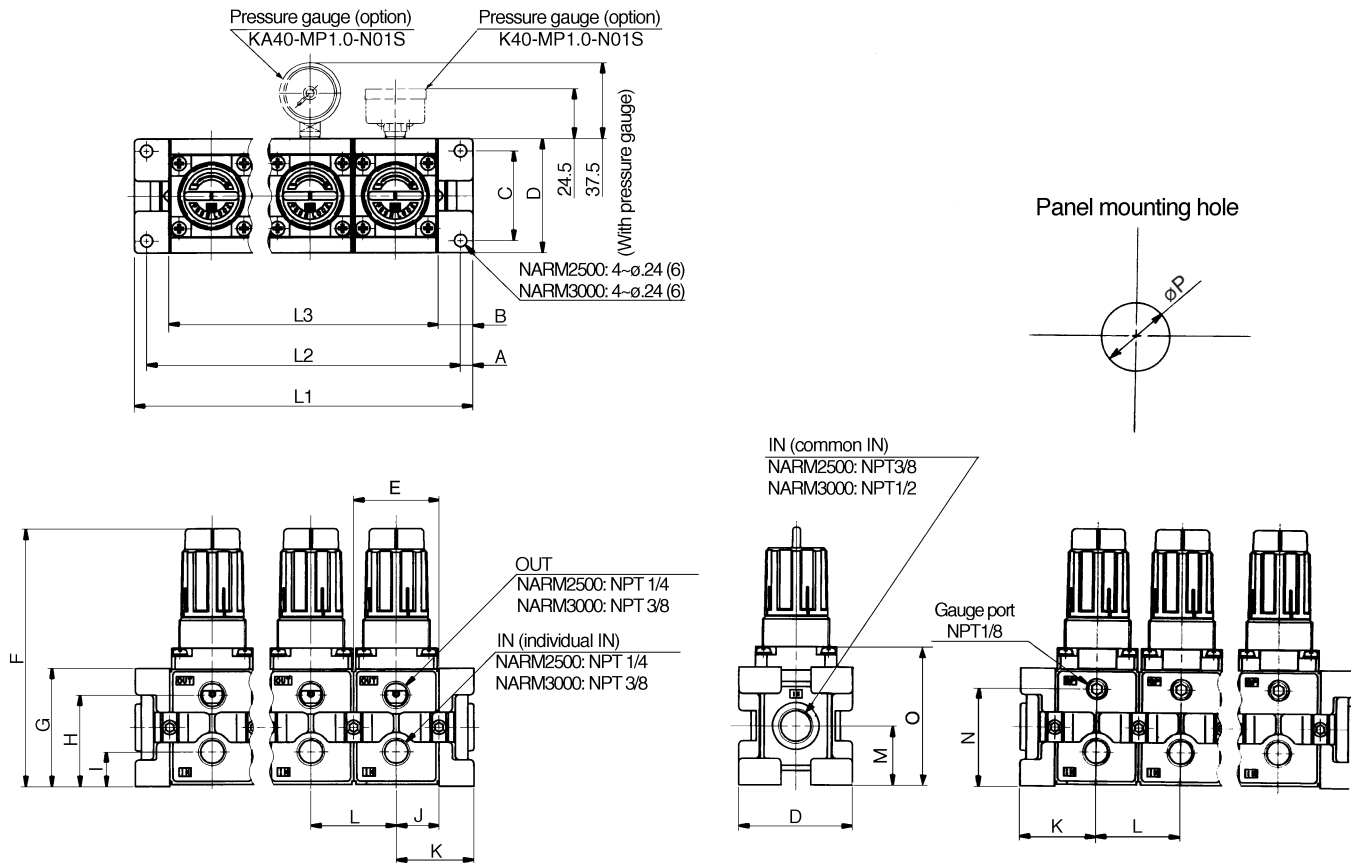

Dimensions

Model	Symbol	A	B	C	D	E	F	G	H	I	J	K	L	M	N	O	P
NARM2500		.24	.67	1.73	2.20	1.65	4.98	2.28	1.77	.67	.83	1.50	1.65	1.14	1.89	2.68	1.32
		(6)	(17)	(44)	(56)	(42)	(126.5)	(58)	(45)	(17)	(21)	(38)	(42)	(29)	(48)	(68)	(33.5)
NARM3000		.28	.83	2.13	2.68	2.17	6.04	2.76	2.09	.93	1.08	1.91	2.17	1.38	2.32	3.37	1.67
		(7)	(21)	(54)	(968)	(55)	(153.5)	(70)	(53)	(23.5)	(27.5)	(48.5)	(55)	(35)	(59)	(85.5)	(42.5)

Dimensions by number of stations

Model	Symbol	2	3	4	5	6	7	8	9	10
NARM2500	L1	4.66 (118)	6.30 (160)	7.95 (202)	9.61 (244)	11.26 (286)	12.91 (328)	14.57 (370)	16.22 (412)	17.87 (454)
	L2	4.17 (106)	5.83 (148)	7.48 (190)	9.13 (232)	10.79 (274)	12.44 (316)	14.09 (358)	15.75 (400)	17.40 (442)
	L3	3.31 (84)	4.96 (126)	6.61 (168)	8.27 (210)	9.92 (252)	11.57 (294)	13.23 (336)	14.88 (378)	16.54 (420)
NARM3000	L1	5.98 (152)	8.15 (207)	10.31 (262)	12.48 (317)	14.65 (372)	16.81 (427)	18.98 (482)	21.14 (537)	23.31 (592)
	L2	5.43 (138)	7.60 (193)	9.76 (248)	11.93 (303)	14.10 (358)	16.26 (413)	18.43 (468)	20.59 (523)	22.76 (578)
	L3	4.33 (110)	6.50 (165)	8.66 (220)	10.83 (275)	12.99 (330)	15.16 (385)	17.32 (440)	19.49 (495)	21.65 (550)