

Aluminum

New

RoHS

High Vacuum Angle Valve



Aluminum bodied

- Uniform baking temperature
- Minimal outgassing
- High corrosion resistance to fluorine gas
- Lightweight, Compact
- Minimal contamination from heavy metals

Possible to replace the bellows

Bellows assembly can be replaced which reduces maintenance costs and waste materials.

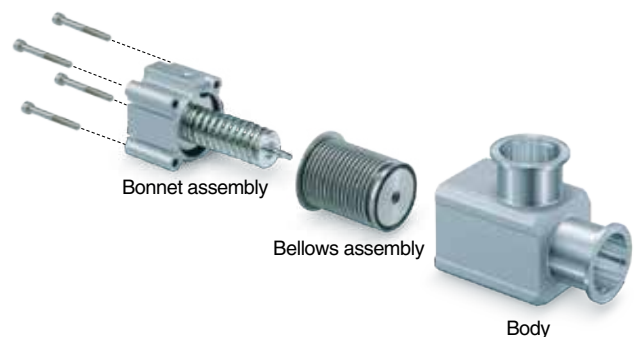

Flange Size Variations

Flange size	Operating pressure [Pa(abs)]		Leakage [Pa·m ³ /s or less]		Option
	KF (NW)	K (DN)	Internal	External	
ø16	●		10 ⁻⁶ to Atmospheric pressure	10 ⁻¹⁰	With auto switch With heater With indicator High temperature type
ø25	●				
ø40	●				
ø50	●				
ø63	●	●			
ø80	●	●			

Series XLA

Uniform baking temperature

Excellent thermal conductivity results in a uniform temperature for the entire valve body and a marked decrease in the condensation of gases inside the valve.

Comparison with KF25 flange

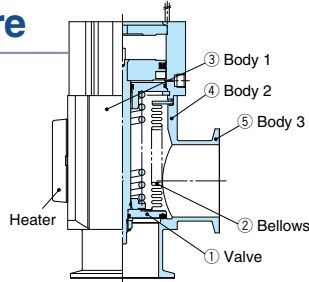

Temperature distribution of 248°F [120°C] specification

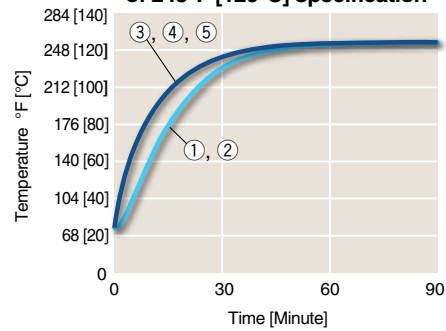

Lightweight, Compact

Large conductance, small body
Excellent resistance against fluorine corrosion (body)

Series XLA

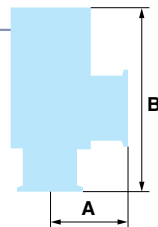

Model	A [mm]	B [mm]	Weight [kg]	Conductance
XLA-16-2	40	108	0.28	5
XLA-25-2	50	121	0.47	14
XLA-40-2	65	171	1.1	45
XLA-50-2	70	185	1.8	80
XLA-63-2	88	212	3.1	160
XLA-80-2	90	257	5.1	200

Low outgassing

Low outgassing makes it possible to use a lower capacity pump and also to shorten exhaust time.

Little heavy metal contamination

The valve does not contain heavy metals such as Ni (nickel) or Cr (chrome) and a low sputtering yield also helps to minimize heavy metal contamination of semiconductor wafers.

Heater is available for option.

For 212/248°F [100/120°C]



Auto switches are mountable.



High Vacuum Angle Valve Series Variations



Type	Series	Valve type	Shaft seal type	Application	Flange size										
					16	25	40	50	63	80	100	160			
Air operated	XLA		Single acting (N.C.)	Bellows seal	Dust free, cleaned	●	●	●	●	●	●				 Best Pneumatics
	XLAV (With solenoid valve)		Single acting (N.C.)	Bellows seal	Dust free, cleaned	●	●	●	●	●	●				
	XLC		Double acting			●	●	●	●	●	●				
	XLCV (With solenoid valve)			●	●	●	●	●	●						
	XLF		Single acting (N.C.)	O-ring seal	High speed operation	●	●	●	●	●	●	●	●	●	
	XLFV (With solenoid valve)					●	●	●	●	●	●	●	●	●	
	XLG		Double acting	O-ring seal	High operating cycles	●	●	●	●	●	●	●	●	●	
	XLGV (With solenoid valve)					●	●	●	●	●	●				
	XLD		Single acting (N.C.)	Bellows seal O-ring seal	For preventing turbulence of dusts	●	●	●	●	●					
	XLDV (With solenoid valve)				For preventing a pump from running overloaded	●	●	●	●	●					
Manual	XLH		Manual	Bellows seal	Dust free, cleaned	●	●	●	●						
Electro-magnetic	XLS		Single acting (N.C.)	(Bellows balance)	For portable equipment not requiring air	●	●								

*Models with a heater and high temperature type are not available with auto switches.

Aluminum High Vacuum Angle Valve Normally Closed/Bellows Seal Series XLA



XLA

How to Order

XLA - **16** **□** **□** **□** - 2 **M9N** **A** - **□**

① ② ③ ④ ⑤ ⑥ ⑦

① Flange size

Size
16
25
40
50
63
80

② Flange type

Symbol	Type	Applicable flange
Nil	KF(NW)	16, 25, 40, 50, 63, 80
D	K(DN)	63, 80

③ Indicator/Pilot port direction

Symbol	Indicator	Pilot port direction
Nil	Without indicator	Flange side
A	With indicator	Flange side
F		Left flange surface
G		Rear flange surface
J		Right flange surface
K	Without indicator	Left flange surface
L		Rear flange surface
M		Right flange surface

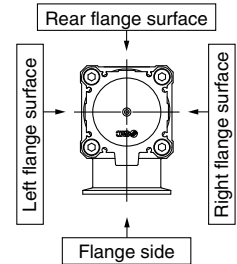

④ Temperature specifications/Heater

Symbol	Temperature	Heater
Nil	41 to 140°F [5 to 60°C]	—
High temperature type	41 to 302°F [5 to 150°C]	—
		With 212°F [100°C] heater
		With 248°F [120°C] heater

Note) Size 16 is not applicable to H4, H5, Size 25 not to H4.

⑥ Number of auto switches/Mounting position

Symbol	Quantity	Mounting position
Nil	Without auto switch	—
A	2 pcs.	Valve open/closed
B	1 pc.	Valve open
C	1 pc.	Valve closed

⑤ Auto switch type

Symbol	Model	Remarks
Nil	—	Without auto switch (without magnet)
M9N(M)(L)(Z)	D-M9N(M)(L)(Z)	Solid state auto switch
M9P(M)(L)(Z)	D-M9P(M)(L)(Z)	
M9B(M)(L)(Z)	D-M9B(M)(L)(Z)	
A90(L)	D-A90(L)	Reed auto switch (Not applicable to flange size 16)
A93(L)(Z)	D-A93(L)(Z)	
M9//	—	Without auto switch (with magnet)

Note 1) Auto switches shown above cannot be mounted on the high temperature type.

Note 2) Standard lead wire length is 0.5 m. Add "M" to the end of the part number when 1 m is desired, "L" when 3 m, and "Z" when 5 m.

Example) -2M9NL

⑦ Body surface treatment/Seal material and its changed part

• Body surface treatment

Symbol	Surface treatment
Nil	External: Hard anodized Internal: Raw material
A	External: Hard anodized Internal: Oxalic acid anodized

• Seal material

Symbol	Seal material	Compound no.
Nil	FKM	1349-80*
N1	EPDM	2101-80*
P1	Barrel Perfluoro®	70W
Q1	Kalrez®	4079
R1	Chemraz®	SS592
R2		SS630
R3		SSE38
S1	VMQ	1232-70*
T1	FKM for Plasma	3310-75*

* Produced by Mitsubishi Cable Industries, Ltd.

Barrel Perfluoro® is a registered trademark of Matsumura Oil Co., Ltd.
Kalrez® is a registered trademark of E. I. du Pont de Nemours and Company or its affiliates.
Chemraz® is a registered trademark of Greene, Tweed & Co.

• Seal material changed part and leakage

Symbol	Changed part ^{Note 2)}	Leakage [Pa·m ³ /s or less] ^{Note 1)}	
		Internal	External
Nil	None	1.3 x 10 ⁻¹⁰ (FKM)	1.3 x 10 ⁻¹¹ (FKM)
A	②, ③, ④	1.3 x 10 ⁻⁸	1.3 x 10 ⁻⁹
B	②, ③	1.3 x 10 ⁻⁸	1.3 x 10 ⁻⁹
C	④	1.3 x 10 ⁻¹⁰ (FKM)	1.3 x 10 ⁻⁹
D	②	1.3 x 10 ⁻⁸	1.3 x 10 ⁻¹¹ (FKM)
E	②, ④	1.3 x 10 ⁻⁸	1.3 x 10 ⁻⁹

Note 1) Values at normal temperature, excluding gas permeation

Note 2) Refer to "Construction" on page 4 for changed part. Number indicates parts number of "Construction" accordingly.

To order something other than "Nil" (standard), list the symbols starting with "X," followed by each symbol for "body surface treatment," "seal material" and then "changed part."

Example) XLA-16-2M9NA-XAN1A

Specifications

Model	XLA-16-2	XLA-25-2	XLA-40-2	XLA-50-2	XLA-63-2	XLA-80-2
Valve type	Normally closed (Pressurize to open, Spring seal)					
Fluid	Inert gas under vacuum					
Operating temperature	41 to 140°F [5 to 60°C] (High temperature type: 41 to 302°F [5 to 150°C])					
Operating pressure Pa(abs)	1 x 10 ⁻⁶ to Atmospheric pressure					
Conductance L/s <small>Note 1)</small>	5	14	45	80	160	200
Leakage Pa·m ³ /s	Internal	For standard seal material (FKM): 1.3 x 10 ⁻¹⁰ at normal temperature, excluding gas permeation				
	External	For standard seal material (FKM): 1.3 x 10 ⁻¹¹ at normal temperature, excluding gas permeation				
Flange type	KF(NW)				KF(NW), K(DN)	
Principal materials	Body: Aluminum alloy, Bellows: Stainless steel 316L, Chief part: Stainless steel, FKM (Standard seal material)					
Surface treatment	External: Hard anodized Internal: Raw material					
Pilot pressure	58 to 102 psi [0.4 to 0.7 MPa (G)]					
Pilot port size	M5			Rc1/8		
Weight kg	0.28	0.47	1.1	1.7	3.1	5.1

Note 1) Conductance is the value for the "molecular flow" of an elbow with the same dimensions.

Note 2) For heater specifications, refer to "Common Option [1] Heater" on page 6.

Construction/Operation

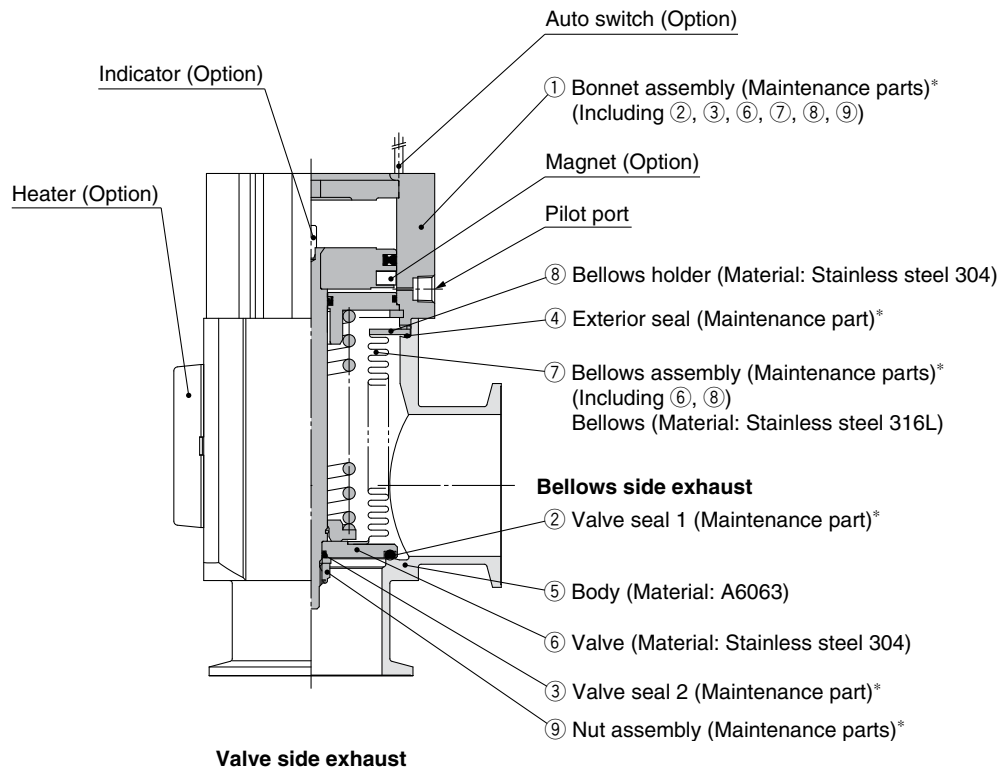

* Refer to "Maintenance Parts" on page 10.

<Working principle>

By applying pilot pressure from the pilot port, the piston-coupled valve overcomes the force of the spring or operating force by pressure, and the valve opens.

<Option>

Auto switch: The magnet activates the auto switch. With 2 auto switches, the open and closed positions are detected, and with 1 auto switch, either the open or closed position is detected. The temperature range is only available for general use (41 to 140°F [5 to 60°C]).

Heater: Heating is performed simply using thermistors. The valve body can be heated to approximately 212°F [100°C] or 248°F [120°C], depending on the size of the product. The type and number of thermistors to be used will vary depending on the size and setting temperature. In the case of high temperature specification, the bonnet assembly is a heat resistant structure.

Indicator: When the valve is open, a marker appears in the center of the upper surface of the bonnet.

Dimensions

XLA: Air operated

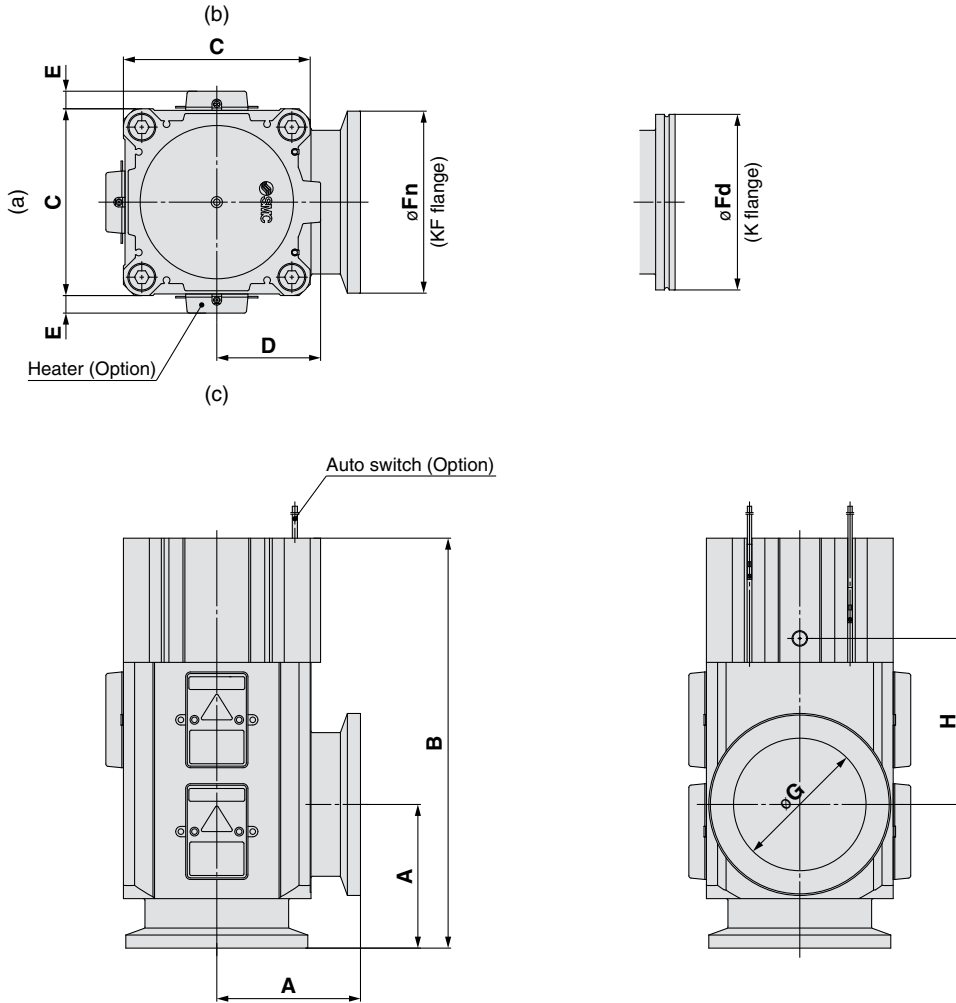

[mm]

Model	A	B	C	D	E ^{Note 1)}	Fn	Fd	G	H
XLA-16-2	40	108	38	20	—	30	—	17	44
XLA-25-2	50	121	48	27	12	40	—	26	44
XLA-40-2	65	171	66	39	11	55	—	41	67
XLA-50-2	70	185	79	46	11	75	—	52	72
XLA-63-2	88	212	100	55	11	87	95	70	76
XLA-80-2	90	257	117	65	11	114	110	83	104

Note 1) The E dimension applies when heater option is included. (Lead wire length: Approx. 1 m)

Note 2) (a), (b), (c) in the above drawing indicate heater mounting positions.

Moreover, heater mounting positions will differ depending on the type of heater.
For details, refer to "Common Option [2] Mounting position of heater" on page 6.

Common Option

1 Heater

Power consumption specifications are shown below.

Model		XLA-25-2	XLA-40-2	XLA-50-2	XLA-63-2	XLA-80-2	
Rated voltage for heater		90 to 240 VAC					
Heater assembly quantity used Heater power W (Nominal value) Inrush/Power consumption (Option symbol, Operating voltage)	Heater assembly quantity	—	1 pc.	1 pc.	1 pc.	1 pc.	
	H4 212°F [100°C]	100 V	—	200/40	200/50	400/100	600/150
		200 V	—	800/40	800/50	800/100	2400/150
	Heater assembly quantity	1 pc.	1 pc.	1 pc.	1 pc.	2 pcs.	
H5 248°F [120°C]	100 V	200/40	400/70	400/80	600/130	800/180	
	200 V	800/40	1600/80	1600/80	2400/130	3200/180	

* The inrush current of the heater flows for several ten seconds when using 100 V while it flows for several seconds when using 200 V. However, this inrush current decreases for some time.

* When the product uses multiple heater assemblies, do not turn on the power to each heater assembly at the same time. Turn on the power to each heater assembly one-by-one in order at intervals of 30 sec. since the inrush current is large.

* Refer to "Maintenance Parts" on page 10 for further details regarding quantity and type.

Inrush Current Flow Time (Reference)

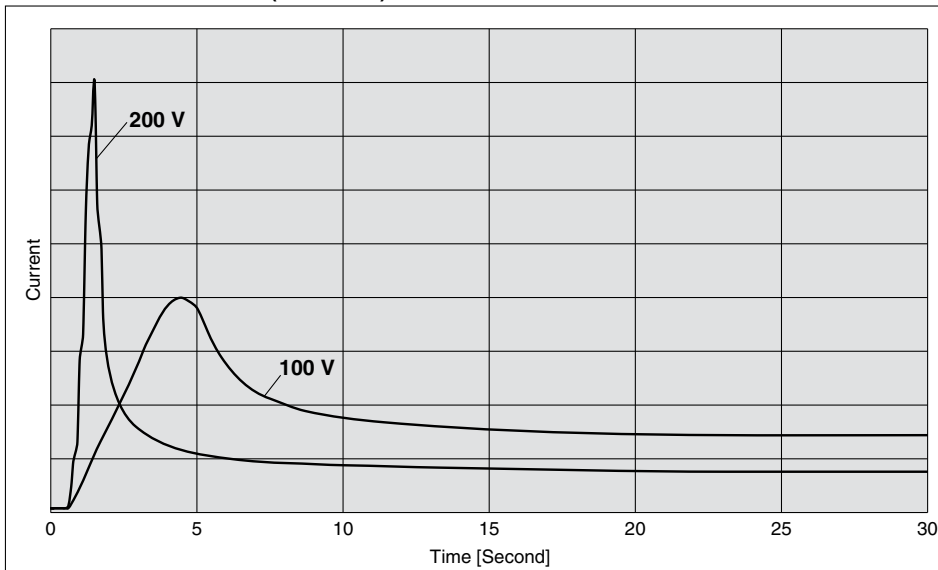

2 Mounting position of heater

Heater symbol	XLA-25-2	XLA-40-2	XLA-50-2	XLA-63-2	XLA-80-2
H4 (212°F [100°C])	—	(a)	(a)	(b), (c)	(a), (b), (c)
H5 (248°F [120°C])	(a)	(b), (c)	(b), (c)	(a), (b), (c)	(b), (c)

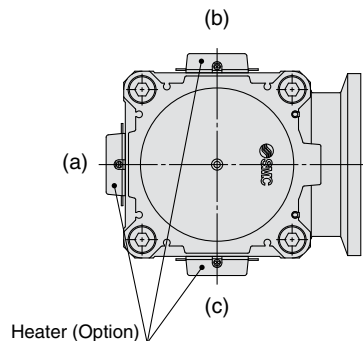

1 Seal Materials

Note that the following are general features and subject to change depending on processing conditions. For details, please contact sealing component manufacturers.

FKM (Fluororubber)

With low outgassing, low permanent setting and low gas permeation rates, this is the most popular seal material for high vacuums. Standard material used by SMC's high vacuum angle valve is Mitsubishi Cable Industries, Ltd. (Compound no. 1349-80). It is advisable to choose a model depending on its application, because an improved material compound (3310-75) which reduces the weight reduction ratio with O₂ plasma is also available.

Kalrez® * Kalrez® is a registered trademark of E. I. du Pont de Nemours and Company or its affiliates.

This material, perfluoroelastomer (FFKM), has excellent heat and chemical resistance, but its permanent setting is large, and special caution is required. Variations are available with improved plasma (O₂, CF₄) and particulate resistance; therefore, it is advisable to select types based on the application.

Compound no. 4079: Standard Kalrez®, excellent in gas and heat resistance.

Chemraz® * Chemraz® is a registered trademark of Greene, Tweed & Co. This material, perfluoroelastomer (FFKM), has excellent chemical and plasma resistance and has slightly higher heat resistance than FKM. Several variations of Chemraz® are available and it is advisable to choose based on the particular plasma being used and other conditions etc.

Compound no. SS592: Excellent physical properties and especially effective for moving parts.

Compound no. SS630: Applicable to both fixed and moving parts and compatible with a wide variety of applications.

Compound no. SSE38: The cleanest material among Chemraz®, developed for high density plasma instruments.

Barrel Perfluoro® * Barrel Perfluoro® is a registered trademark of Matsumura Oil Co., Ltd.

Compound no. 70W: Perfluoroelastomer (FFKM) which does not contain a metal filler. Resistant against NF₃, NH₃. Low particle generation under dry process conditions and relatively small permanent-setting.

Silicone (Silicone rubber, VMQ)

This material is relatively inexpensive, has good plasma resistance, but its gas permeation rate is high.

Optional seal material used by SMC's high vacuum angle valve is Mitsubishi Cable Industries, Ltd. (Compound no. 1232-70, White) It has a low weight reduction ratio and low particle generation within O₂ plasma and NH₃ gas environments.

EPDM (Ethylene propylene rubber)

Relatively lower priced and excellent in weatherability, chemical and heat resistance, but with no resistance at all to general mineral oil. Optional seal material used by SMC's high vacuum angle valve is Mitsubishi Cable Industries, Ltd. (Compound no. 2101-80) Resistant to NH₃ gas etc.

2 Shaft Sealing Method

Bellows

Bellows offer cleaner sealing with reduced dust generation and less outgassing. The two major bellows types are: Formed-bellows and Welded-bellows. Formed-bellows produce less dusts and offer higher dust resistance. Welded-bellows allow longer strokes, but generate more dusts and offer less dust resistance. Note that the endurance depends on length and speed of the strokes.

O-ring etc.

Due to entrainment of gases and dust generation, vacuum performance is somewhat inferior to the bellows type. However, high speed operation is possible and durability is comparatively high. In general, fluorinated grease is affixed to the shaft seal portion.

3 Response Time/Operation Time

Valve opening

The time from the application of voltage to the pilot solenoid valve until 90% of the valve (XL□) stroke has been completed, is the valve opening response time. Valve opening operation time indicates the time from the start of the stroke until 90% of movement has been completed. Both of these become faster as the pilot pressure is increased.

Valve closing

The time from the cut off of power to the pilot solenoid valve until 90% of the valve (XL□) return stroke has been completed, is the valve closing response time. Valve closing operation time indicates the time from valve opening until 90% of return movement has been completed. Both of these become slower as the pilot pressure is increased.

4 Molecular Flow Conductance

Orifice conductance

In the case of a ϕA (cm²) hole in an ultra-thin plate, conductance "C" results from "V", the average velocity of the gas; "R", the gas constant; "M", the molecular weight; and "T", the absolute temperature. From the formula $C=VA/4=(RT/2\pi M)^{0.5}A$, the conductance $C=11.6A$ (L/sec) at an air temperature of 68°F [20°C].

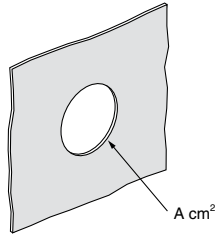

Cylinder conductance

With length "L" (cm) and diameter "D" (cm) where $L \gg D$, from the formula $C=(2\pi RT/M)^{0.5}D^3/6L$, the conductance $C=12.1 D^3/L$ (L/sec) at an air temperature of 68°F [20°C].

Short pipe conductance

From the Clausing factor "K" and hole conductance "C" in Graph 1. (Clausing factor drawing), the short pipe conductance CK is easily found as $CK=KC$.

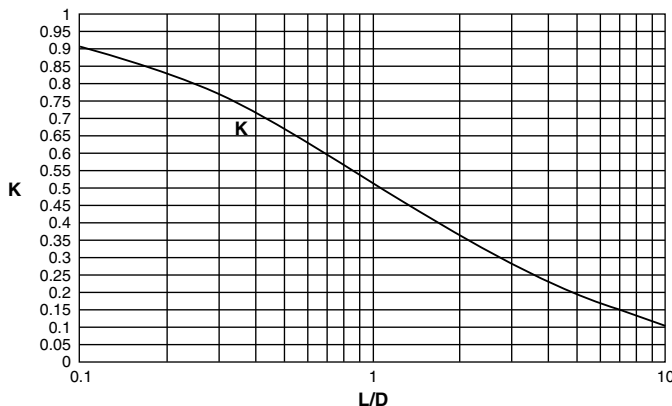

Graph 1. Clausing factor

Conductances combined

When each of the separate conductances are given as C_1 , C_2 and C_n , the composite conductance ΣC is expressed as:

$\Sigma C=1/(1/C_1+1/C_2+\dots+1/C_n)$ when in series, and

$\Sigma C=C_1+C_2+\dots+C_n$, when in parallel.

5 He Leakage

Surface leakage

This leakage occurs between surfaces of the sealing and the seal material. In the case of elastic body seal (elastomer), leakage values are confirmed within minutes of operation.

Leakage rate is measured at room temperature (68 to 86°F [20 to 30°C]).

Gas permeation

This is leakage caused by diffusion through the elastic body seal material. As temperature increases, the diffusion rate increases, and in many cases, becomes greater than surface leakage. The diffusion rate is proportional to the cross sectional area (cm²) of the seal, and inversely proportional to the seal width (distance between the atmosphere and the vacuum side). In the case of metal gaskets, only hydrogen diffusion should be considered.

6 Outgassing

This is a phenomenon where gases adhered or adsorbed to the metallic surface or its inside parts are released from the surface and drawn into the vacuum according to the pressure decrease. The smoothness of the surface and closeness of the oxidized layer can effect (increase/decrease) this.

7 Ultimate Pressure

Ultimate pressure P (Pa) is $P=Q/S$, where the sum of Weight flow rates for outgassing (Qg) and leakage Q(L) is Q(Pa·m³/s), and the exhaust speed is S(m³/s). The ultimate pressure is measured with Qg, Q(L)S shown as above, and the ultimate pressure of the pump itself. In the case of very low pressure, the exhaust characteristics of the actual pump can be the limiting factor. In particular, a deterioration of exhaust characteristics due to an unclean pump and invasion of the atmospheric moisture can be the major factor.

8 Exhaust Time (Low/Medium Vacuum)

The time (Δt) required to exhaust a chamber at low vacuum with volume V (L), from pressure P1 to P2, using a pump with pumping speed S (L/sec) is $\Delta t=2.3(V/S)\log(P1/P2)$. In high vacuum, this is subject to the ultimate pressure limit imposed by outgassing and leakage as characterized above.

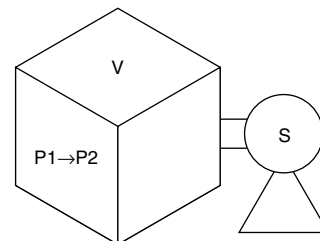

9 Baking

Gases such as oxygen and nitrogen, which have a small adsorption activation energy (E) and a short adsorption residence time (τ), are evacuated quickly. However, in the case of water, which has a high activation energy, evacuation does not progress quickly unless the temperature (T: absolute temperature) is raised to shorten residence time. This time is characterized as $\tau=\tau_0 \exp(E/RT)$ where R is the ideal gas constant and $\tau_0=(\text{approx.}) 10^{-13}$ sec.

Residence time of water at 68°F [20°C] is 5.5×10^{-6} sec, whereas at 302°F [150°C], it is 2.8×10^{-8} sec, or about 200 times shorter. The objective of baking is to exhaust water with long adsorption residence time more quickly.



Series XLA Specific Product Precautions 1

Be sure to read this before handling. Refer to the back cover for Safety Instructions. For Auto Switch Precautions, refer to "Handling Precautions for SMC Products" and the Operation Manual on SMC website, <http://www.smcworld.com>

Air Operated Angle Valve/Series XLA

Design

Warning

• All models

1. The body material is A6063, the bellows are made of stainless steel 316L, and other metal material in the vacuum section is stainless steel 304. Standard seal material in the vacuum section is FKM that can be changed to the other materials (refer to "How to Order"). Use fluids which are compatible with materials after confirming.
2. Select materials for the actuation pressure piping, and heat resistance for fittings that are suitable for the applicable operating temperatures.

• Model with auto switch

1. The auto switch section temperature should not exceed 140°F [60°C].

• Model with heater

1. For models with a heater (thermistor), a device should be installed to prevent overheating.
2. If using gases that cause a large amount of deposits, heat the valve body to prevent deposits in the valve.

Selection

Caution

• All models

1. For high vacuum valves used in the main exhaust lines of flat panel display manufacturing equipment and other large manufacturing equipment, the XLF(V) or XLG(V) series, employing O-ring seal type for improved durability, is recommended.
2. When controlling product responsiveness, take note of the size and length of piping, as well as the flow rate characteristics of the pilot solenoid valve.
3. Pilot pressure should be kept within the specified range.
58 to 73 psi [0.4 to 0.5 MPa] is recommended.
4. Use within the operating pressure range.
5. Use within the operating temperature range.
6. The actuating piston chamber and the bellows chamber are directly connected to atmosphere.
Use in an environment where dust emissions will not cause problems. (Please consult with SMC if the release of dust must be avoided.)
7. If a product other than built-in magnet type is selected without auto switches, then the auto switch cannot be mounted later.

Mounting

Caution

• All models

1. In high humidity environments, keep valves packaged until the time of installation.
2. For models with an auto switch, secure the lead wires so that they have sufficient slack, without any unreasonable force applied to them.
3. Perform piping so that excessive force is not applied to the flange section. When there is vibration of heavy objects or attachments, etc., secure them so that torque is not applied directly to the flanges.

Mounting

Caution

4. Vibration resistance allows for normal operation up to 30 m/s² (45 to 250 Hz), but continuous vibration may cause a decline in durability. Arrange piping to avoid excessive vibrations or shocks.

• High temperature type (H0, H4, H5)

1. For models with a heater (thermistor), take care not to damage the insulation components of the lead wires and connector section.
2. The setting temperature for models with a heater should be established without a draft or heat insulation. It will change depending on conditions such as heat retaining measures and the heating of other piping. Fine adjustment is not possible.
3. When installing heater accessories or mounting a heater, check insulation resistance at the actual operating temperature. Installation of a short circuit breaker etc. is recommended.
4. When a product is to be heated, only the body section should be heated, excluding the bonnet section.
5. When a heater is in operation, the entire product becomes hot. Be careful not to touch it with bare hands, as burns will result.

Piping

Caution

1. Before mounting, clean the flange seal surface and the O-ring with ethanol etc.
2. There is an indentation of 0.1 to 0.2 mm in order to protect the flange seal surface, and it should be handled so that the seal surface is not damaged in any way.
3. Exhaust direction
During operation, the direction of the exhaust may be determined freely, but in cases where a flow is generated by the exhaust, a decline in durability may result. The exhaust direction shown in the figure below (bellows side exhaust) is recommended. Take all available precautions, as the life of the equipment is affected by conditions of usage.

Recommended exhaust direction [Vacuum pump connected on bellows side]

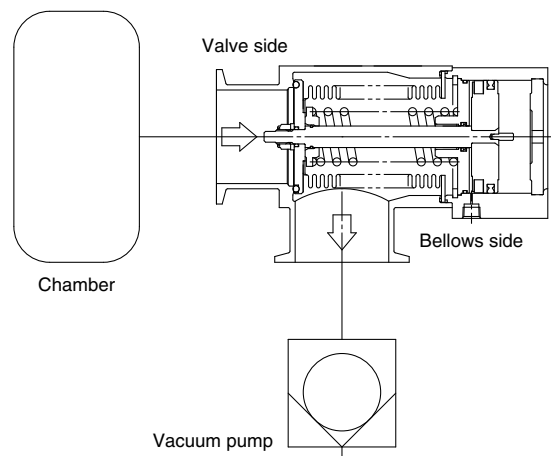



Series XLA Specific Product Precautions 2

Be sure to read this before handling. Refer to the back cover for Safety Instructions. For Auto Switch Precautions, refer to "Handling Precautions for SMC Products" and the Operation Manual on SMC website, <http://www.smcworld.com>

Air Operated Angle Valve/Series XLA

Maintenance

Warning

If the fluid or reaction product (deposit) may deteriorate safety, those who have domain knowledge and experience (specialist of the field) shall disassemble, clean and assemble the products.

Caution

- When removing deposits from a valve, take care not to damage any of its parts.
- Replace the product or bonnet assembly when the end of its service life is approached.
- If damage is suspected prior to the end of the service life, perform early maintenance. If there are scratches, dents or cracks on the seals (bellows or valve) due to handling or operating conditions, replace the parts.
For maintenance parts, refer to "Construction" or "Maintenance Parts."
- SMC specified parts should be used for service.
- When removing valve or exterior seals, take care not to damage the sealing surfaces. When installing the valve seal or exterior seal, be sure that the O-ring is not twisted.
- When the bellows assembly is replaced, do not hold the bellows directly.

Maintenance Parts

Air operated angle valve

Bonnet Assembly

Temperature specification	Indicator	Valve size					
		16	25	40	50	63	80
General use	None	XLA16-30-1-2	XLA25-30-1-2	XLA40-30-1-2	XLA50-30-1-2	XLA63-30-1-2	XLA80-30-1-2
	Yes	XLA16A-30-1-2	XLA25A-30-1-2	XLA40A-30-1-2	XLA50A-30-1-2	XLA63A-30-1-2	XLA80A-30-1-2
High temperature	None	XLA16-30-1H-2	XLA25-30-1H-2	XLA40-30-1H-2	XLA50-30-1H-2	XLA63-30-1H-2	XLA80-30-1H-2
	Yes	XLA16A-30-1H-2	XLA25A-30-1H-2	XLA40A-30-1H-2	XLA50A-30-1H-2	XLA63A-30-1H-2	XLA80A-30-1H-2

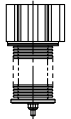

Bonnet assembly

Bellows Assembly/Nut Assembly

Description (Construction no.)	Valve size					
	16	25	40	50	63	80
Bellows assembly ⑦	XL1A16-2-101	XL1A25-2-101	XL1A40-2-101	XL1A50-2-101	XL1A63-2-101	XL1A80-2-101
Nut assembly ⑨	XL1A16-10-1	XL1A25-10-1	XL1A40-10-1	XL1A50-10-1		XL1A80-10-1



Bellows assembly

Note 1) In cases where the valve seal material is other than the standard (FKM: Compound no. 1349-80: made by Mitsubishi Cable Industries, Ltd.), add suffix symbol for seal material (as shown below) to the end of the part number.

Note 2) An auto switch magnet is not installed. In cases where an auto switch magnet is installed, add "-M9/" to the end of the part number. (Not available for high temperature type)

Note 3) Auto switch is not attached. When the product with the auto switch is required, add the symbol for the auto switch to the end of the part number.

Exterior Seal/Valve Seal 1, 2

Description (Construction no.)	Material	Valve size					
		16	25	40	50	63	80
Exterior seal ④	Standard	AS568-025V	AS568-030V	AS568-035V	AS568-039V	AS568-043V	AS568-045V
	Special	AS568-025□	AS568-030□	AS568-035□	AS568-039□	AS568-043□	AS568-045□
Valve seal 1 ②	Standard	B2401-V15V	B2401-V24V	B2401-P42V	AS568-227V	AS568-233V	B2401-V85V
	Special	B2401-V15□	B2401-V24□	B2401-P42□	AS568-227□	AS568-233□	B2401-V85□
Valve seal 2 ③	Standard	B2401-P4V	B2401-P5V	B2401-P6V	B2401-P8V		B2401-P10V
	Special	B2401-P4□	B2401-P5□	B2401-P6□	B2401-P8□		B2401-P10□

Note 4) In cases where the seal material is other than the standard (FKM: Compound no. 1349-80: made by Mitsubishi Cable Industries, Ltd.), add suffix symbol for seal material (as shown below) to the end of the part number (the place of □).

Note 5) Refer to "Construction" of each series for component part numbers.

Table 1: Suffix Symbol for Seal Material

Symbol	-XN1	-XP1	-XQ1	-XR1	-XR2	-XR3	-XS1	-XT1
Seal material	EPDM	Barrel Perfluoro®	Kalrez®		Chemraz®		VMQ	FKM for Plasma
Compound no.	2101-80*	70W	4079	SS592	SS630	SSE38	1232-70*	3310-75*

* Produced by Mitsubishi Cable Industries, Ltd.

Heater

Temperature specification	Valve size				
	25	40	50	63	80
H4 (212°F [100°C])	—	XL1A25-60S-1	XL1A25-60S-1	XL1A25-60S-2	XL1A25-60S-3
H5 (248°F [120°C])	XL1A25-60S-1	XL1A25-60S-2	XL1A25-60S-2	XL1A25-60S-3	XL1A25-60S-2 (2 sets)

Example) In the case of the XLA-80H5-2 with heater, 2 sets of the XL1A25-60S-2 are required.

Safety Instructions

These safety instructions are intended to prevent hazardous situations and/or equipment damage. These instructions indicate the level of potential hazard with the labels of “**Caution**,” “**Warning**” or “**Danger**.” They are all important notes for safety and must be followed in addition to International Standards (ISO/IEC)*1), and other safety regulations.

 **Caution:** **Caution** indicates a hazard with a low level of risk which, if not avoided, could result in minor or moderate injury.

 **Warning:** **Warning** indicates a hazard with a medium level of risk which, if not avoided, could result in death or serious injury.

 **Danger:** **Danger** indicates a hazard with a high level of risk which, if not avoided, will result in death or serious injury.

*1) ISO 4414: Pneumatic fluid power – General rules relating to systems.
ISO 4413: Hydraulic fluid power – General rules relating to systems.
IEC 60204-1: Safety of machinery – Electrical equipment of machines.
(Part 1: General requirements)
ISO 10218-1: Manipulating industrial robots – Safety.
etc.

Warning

1. The compatibility of the product is the responsibility of the person who designs the equipment or decides its specifications.

Since the product specified here is used under various operating conditions, its compatibility with specific equipment must be decided by the person who designs the equipment or decides its specifications based on necessary analysis and test results. The expected performance and safety assurance of the equipment will be the responsibility of the person who has determined its compatibility with the product. This person should also continuously review all specifications of the product referring to its latest catalog information, with a view to giving due consideration to any possibility of equipment failure when configuring the equipment.

2. Only personnel with appropriate training should operate machinery and equipment.

The product specified here may become unsafe if handled incorrectly. The assembly, operation and maintenance of machines or equipment including our products must be performed by an operator who is appropriately trained and experienced.

3. Do not service or attempt to remove product and machinery/equipment until safety is confirmed.

1. The inspection and maintenance of machinery/equipment should only be performed after measures to prevent falling or runaway of the driven objects have been confirmed.
2. When the product is to be removed, confirm that the safety measures as mentioned above are implemented and the power from any appropriate source is cut, and read and understand the specific product precautions of all relevant products carefully.
3. Before machinery/equipment is restarted, take measures to prevent unexpected operation and malfunction.

4. Contact SMC beforehand and take special consideration of safety measures if the product is to be used in any of the following conditions.

1. Conditions and environments outside of the given specifications, or use outdoors or in a place exposed to direct sunlight.
2. Installation on equipment in conjunction with atomic energy, railways, air navigation, space, shipping, vehicles, military, medical treatment, combustion and recreation, or equipment in contact with food and beverages, emergency stop circuits, clutch and brake circuits in press applications, safety equipment or other applications unsuitable for the standard specifications described in the product catalog.
3. An application which could have negative effects on people, property, or animals requiring special safety analysis.
4. Use in an interlock circuit, which requires the provision of double interlock for possible failure by using a mechanical protective function, and periodical checks to confirm proper operation.

Caution

1. The product is provided for use in manufacturing industries.

The product herein described is basically provided for peaceful use in manufacturing industries.

If considering using the product in other industries, consult SMC beforehand and exchange specifications or a contract if necessary.

If anything is unclear, contact your nearest sales branch.

Limited warranty and Disclaimer/ Compliance Requirements

The product used is subject to the following “Limited warranty and Disclaimer” and “Compliance Requirements”.

Read and accept them before using the product.

Limited warranty and Disclaimer

1. The warranty period of the product is 1 year in service or 1.5 years after the product is delivered, whichever is first.*2)

Also, the product may have specified durability, running distance or replacement parts. Please consult your nearest sales branch.

2. For any failure or damage reported within the warranty period which is clearly our responsibility, a replacement product or necessary parts will be provided. This limited warranty applies only to our product independently, and not to any other damage incurred due to the failure of the product.
3. Prior to using SMC products, please read and understand the warranty terms and disclaimers noted in the specified catalog for the particular products.

*2) Vacuum pads are excluded from this 1 year warranty.

A vacuum pad is a consumable part, so it is warranted for a year after it is delivered. Also, even within the warranty period, the wear of a product due to the use of the vacuum pad or failure due to the deterioration of rubber material are not covered by the limited warranty.

Compliance Requirements

1. The use of SMC products with production equipment for the manufacture of weapons of mass destruction (WMD) or any other weapon is strictly prohibited.
2. The exports of SMC products or technology from one country to another are governed by the relevant security laws and regulations of the countries involved in the transaction. Prior to the shipment of a SMC product to another country, assure that all local rules governing that export are known and followed.

Caution

SMC products are not intended for use as instruments for legal metrology.

Measurement instruments that SMC manufactures or sells have not been qualified by type approval tests relevant to the metrology (measurement) laws of each country. Therefore, SMC products cannot be used for business or certification ordained by the metrology (measurement) laws of each country.

 Safety Instructions Be sure to read “Handling Precautions for SMC Products” (M-E03-3) before using.



SMC Corporation of America
10100 SMC Blvd., Noblesville, IN 46060
www.smcusa.com
SMC Pneumatics (Canada) Ltd.
www.smc Pneumatics.ca

(800) SMC.SMC1 (762-7621)
e-mail: sales@smcusa.com
For International inquiries: www.smcworld.com