

ISO Cylinder ISO Standard (15552)

ø32, ø40, ø50, ø63, ø80, ø100

Lightweight **Up to 17%** **Weight reduced**

* Compared with the existing C96 series (ø40, 100 stroke)

■ By adopting a new cushion method (**Air cushion** + **Bumper cushion**),

Cycle time shortened

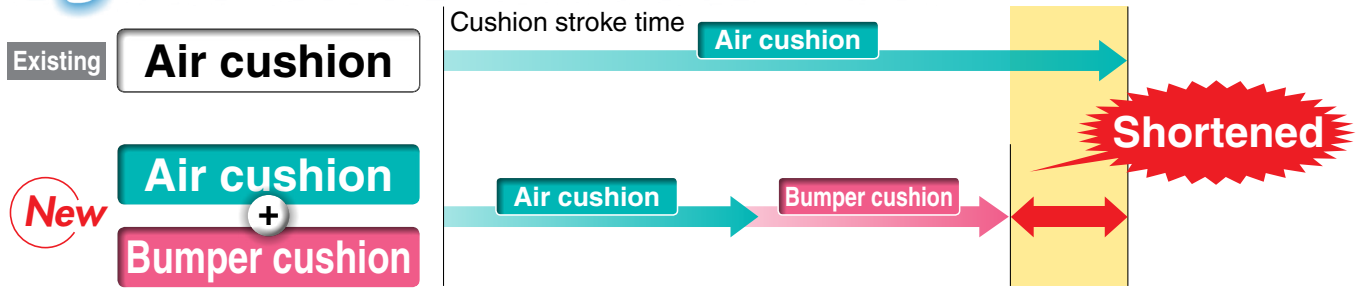

■ Bumper cushion reduces the metal noise that occurs when piston stops



Series C96

New Series C96

Weight reduced

Achieved weight reduction by changing rod cover shape and piston structure

(kg)

Bore size (mm)	New C96	Reduction rate
32	0.65	13%
40	0.96	17%
50	1.57	13%
63	1.94	14%
80	3.12	13%
100	4.03	12%

* Compared with the existing C96 series (ø40, 100 stroke)

Air cushion + Bumper cushion Combined structure

- The cushion stroke time can now be reduced with the double cushioning, which improves the cycle time.
- The bumper cushion reduces the metal noise that occurs when the piston stops at the end of the stroke.

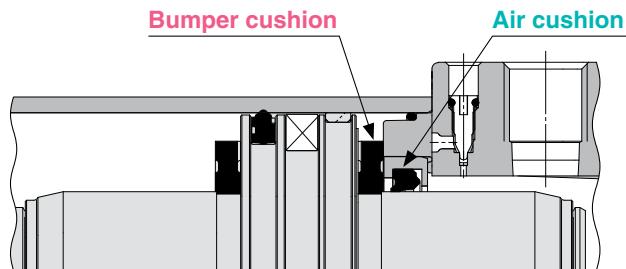

Rod end nut can be screwed up to TRP.

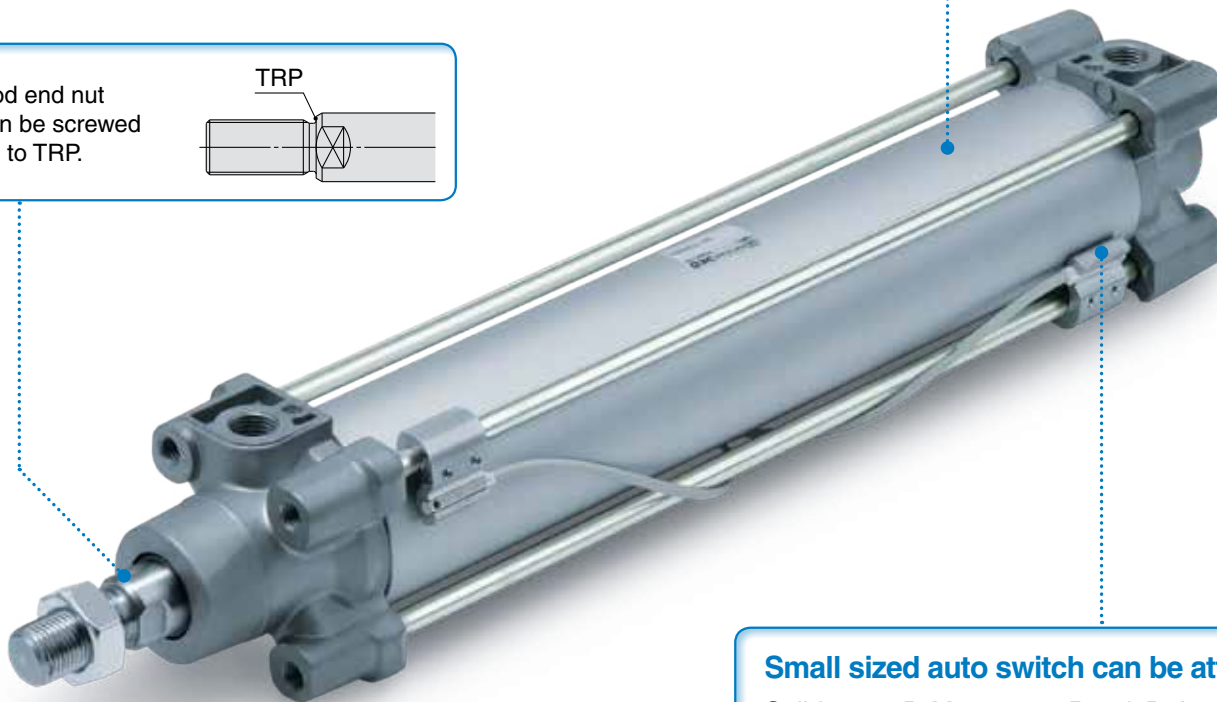
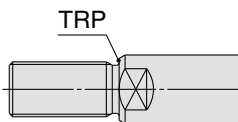

Small sized auto switch can be attached.

Solid state: D-M9□ Reed: D-A9□
D-M9□W

Auto switch mounting screw

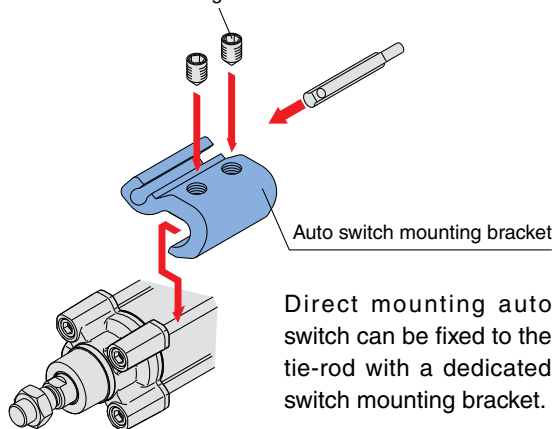

Improved handling performance

Auto switch mounting and mounting position adjustment can be made in a one way direction.

Tie-rod mounting auto switch

2-way

Direct mounting auto switch

1-way

Existing

New method

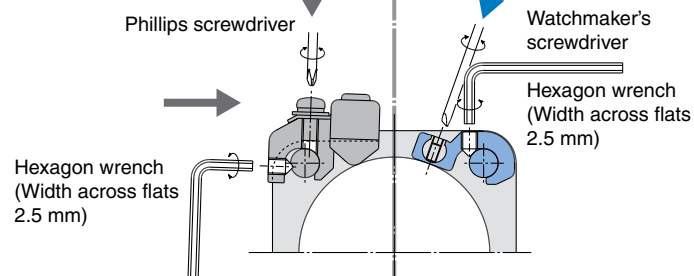

Various mounting bracket options

Mounting brackets can be combined according to the operating conditions.

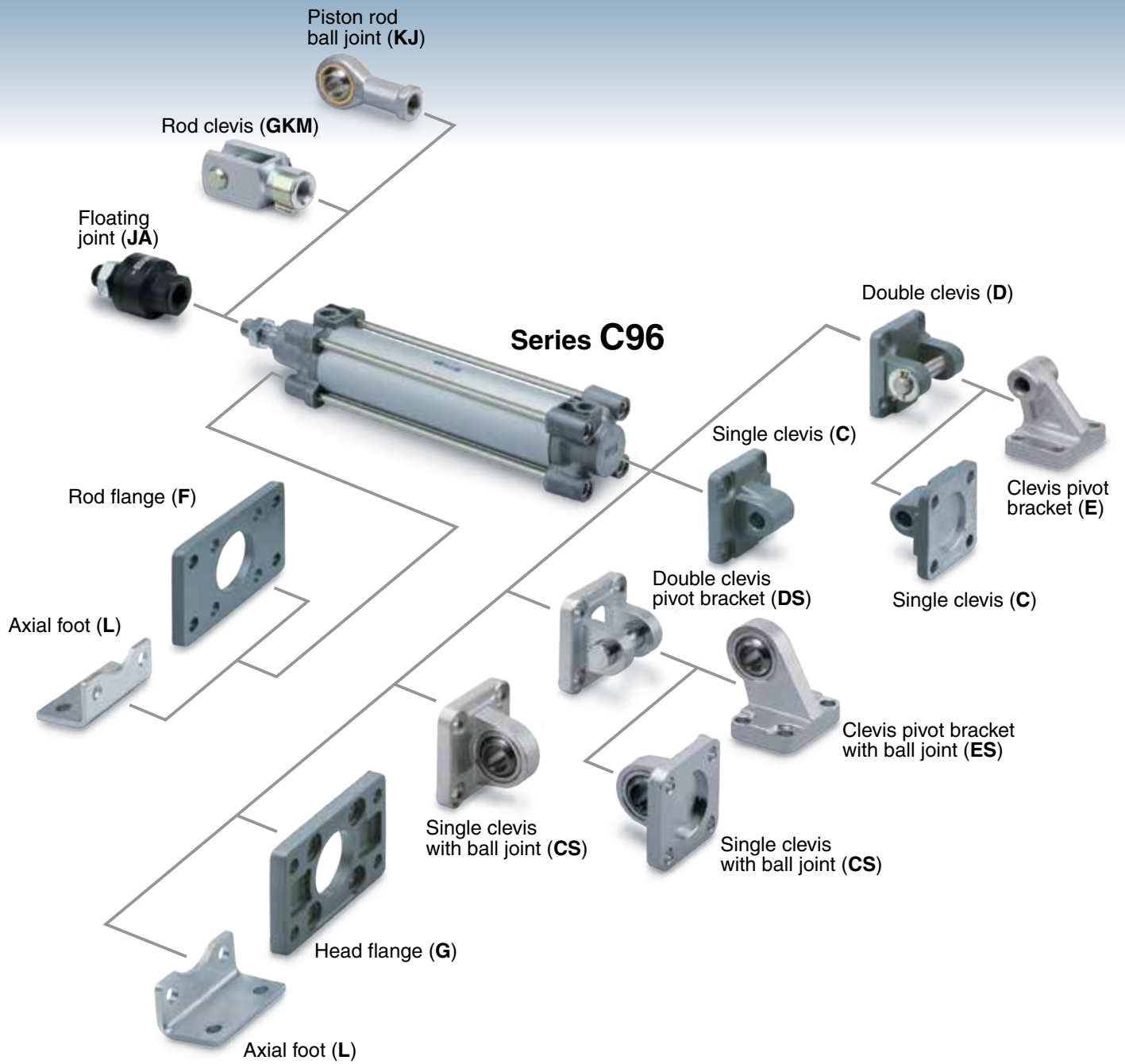

ISO Standard (15552)

Air Cylinder: Standard Type/Double Acting, Single Rod

Series C96

ø32, ø40, ø50, ø63, ø80, ø100

How to Order

C96S **B** **32** - **100** **C**

With auto switch **C96SD** **B** **32** - **100** **C** - **M9BW** **S**

Mounting ●

With auto switch ●
(Built-in magnet)

Bore size ●

Cylinder stroke ●
(mm)
Refer to "Standard Strokes" on page 4.

Auto switch ●

Number of auto switches

Nil	2 pcs.
S	1 pc.
3	3 pcs.
n	"n" pcs.

Auto switch

Nil	Without auto switch
-----	---------------------

* For applicable auto switches, refer to the table below.

● **Air cushion on both ends + Bumper cushion**

B	Basic
L	Axial foot
F	Rod flange
G	Head flange
C	Single clevis
D	Double clevis
T	Center trunnion

32	32 mm
40	40 mm
50	50 mm
63	63 mm
80	80 mm
100	100 mm

* Mounting brackets are shipped together, (but not assembled).
(except center trunnion type)

Applicable Auto Switches/Refer to the WEB catalog or the Best Pneumatics No. 2 for further information on auto switches.

Type	Special function	Electrical entry	Indicator light	Wiring (Output)	Load voltage		Auto switch model		Lead wire length (m)				Pre-wired connector	Applicable load				
					DC	AC	Tie-rod mounting	Band mounting	0.5 (Nil)	1 (M)	3 (L)	5 (Z)						
Solid state auto switch	—	Grommet	—	3-wire (NPN)	24 V	5 V, 12 V	—	M9N	●	●	●	○	○	IC circuit	Relay, PLC			
				3-wire (PNP)				M9P	●	●	●	○	○					
				2-wire				M9B	●	●	●	○	○					
		Terminal conduit		3-wire (NPN)	24 V	5 V, 12 V	—	100 V, 200 V	J51	●	—	●	○	—		—	IC circuit	
				2-wire					G39	—	—	—	—	—		—		
				3-wire (NPN)					K39	—	—	—	—	—		—	—	
	Diagnostic indication (2-color indication)	Grommet	Yes	24 V	5 V, 12 V	—	—	M9NW	—	●	●	●	○	○		IC circuit		
								3-wire (PNP)	M9PW	—	●	●	●	○		○	IC circuit	
								2-wire	M9BW	—	●	●	●	○		○	—	
		Grommet						3-wire (NPN)	M9NA**	—	○	○	●	○		○	IC circuit	
								3-wire (PNP)	M9PA**	—	○	○	●	○		○	IC circuit	
								2-wire	M9BA**	—	○	○	●	○		○	—	
With diagnostic output (2-color indication)	Grommet	—	24 V	5 V, 12 V	—	—	F59F	—	●	—	●	○	○	IC circuit				
Magnetic field resistant (2-color indication)							P4DW	—	—	—	●	●	○	—				
Reed auto switch	—	Grommet	Yes	3-wire (NPN Equivalent)	24 V	12 V	—	A96	—	●	—	●	—	—	IC circuit	Relay, PLC		
				No				2-wire	100 V	A93	—	●	—	●	●		—	—
									100 V or less	A90	—	●	—	●	—		—	IC circuit
									100 V, 200 V	A54	—	●	—	●	●		—	—
		Yes		2-wire	200 V or less	A64	—	●	—	●	—	—	—					
					—	A33	—	—	—	—	—	—	—	PLC				
		Terminal conduit		Yes	2-wire	24 V	100 V, 200 V	—	—	A34	—	—	—	—	—		—	Relay, PLC
										A44	—	—	—	—	—		—	
DIN terminal	Yes	2-wire	24 V	100 V, 200 V	—	—	A59W	—	●	—	●	—	—	Relay, PLC				
							Grommet	2-wire	24 V	—	—	—	—	—	●	—	●	—

** Water resistant type auto switches can be mounted on the above models, but in such case SMC cannot guarantee water resistance.

* Lead wire length symbols: 0.5 m Nil (Example) M9NW
 1 m M (Example) M9NWM
 3 m L (Example) M9NWL
 5 m Z (Example) M9NWZ

* Solid state auto switches marked with "○" are produced upon receipt of order.

* Since there are other applicable auto switches than listed above, refer to the WEB catalog or the Best Pneumatics No. 2 for details.

* For details about auto switches with pre-wired connector, refer to the WEB catalog or the Best Pneumatics No. 2.

* The D-A9I/M9I/M9IW/M9IA auto switches are shipped together, (but not assembled).
 (However, only the auto switch mounting brackets are assembled before shipment.)

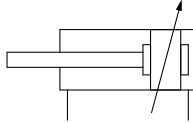

Specifications

Bore size (mm)	32	40	50	63	80	100
Action	Double acting					
Fluid	Air					
Proof pressure	218 psi (1.5 MPa)					
Max. operating pressure	145 psi (1.0 MPa)					
Min. operating pressure	7.3 psi (0.05 MPa)					
Ambient and fluid temperature	Without auto switch: -4 to 158 psi (-20 to 70°C) (No freezing) With auto switch: 14 to 140°F (-10 to 60°C) (No freezing)					
Lubrication	Not required (Non-lube)					
Operating piston speed	50 to 1000 mm/s					
Allowable stroke tolerance	Up to 500 stroke: $^{+2}_0$, 501 to 1000 stroke: $^{+2.4}_0$, 1001 to 1500 stroke: $^{+2.8}_0$, 1501 to 2000 stroke: $^{+3.2}_0$					
Cushion	Air cushion on both ends + Bumper cushion					
Port size	G1/8	G1/4	G1/4	G3/8	G3/8	G1/2
Mounting	Basic, Axial foot, Rod flange, Head flange, Single clevis, Double clevis, Center trunnion					

Minimum Stroke for Auto Switch Mounting

Refer to "Minimum Stroke for Auto Switch Mounting" on page 13.

Standard Strokes

Bore size (mm)	Standard stroke (mm)	Max. stroke ^{Note)}
32	25, 50, 80, 100, 125, 160, 200, 250, 320, 400, 500	1000
40	25, 50, 80, 100, 125, 160, 200, 250, 320, 400, 500	1900
50	25, 50, 80, 100, 125, 160, 200, 250, 320, 400, 500, 600	1900
63	25, 50, 80, 100, 125, 160, 200, 250, 320, 400, 500, 600	1900
80	25, 50, 80, 100, 125, 160, 200, 250, 320, 400, 500, 600, 700, 800	1900
100	25, 50, 80, 100, 125, 160, 200, 250, 320, 400, 500, 600, 700, 800	1900

Intermediate strokes are available.

Note) Please consult with SMC for longer strokes.

Accessories

Mounting		Basic	Foot	Rod flange	Head flange	Single clevis	Double clevis	Center trunnion
Standard	Rod end nut	●	●	●	●	●	●	●
	Clevis pin	—	—	—	—	—	●	—
Option	Piston rod ball joint	●	●	●	●	●	●	●
	Rod clevis	●	●	●	●	●	●	●
	Rod boot	●	●	●	●	●	●	●

* Do not use a piston rod ball joint (or floating joint) together with a single clevis with a ball joint (or clevis pivot bracket with a ball joint).

Series C96

Theoretical Output



(N)

Bore size (mm)	Rod size (mm)	Operating direction	Piston area (mm ²)	Operating pressure (MPa)									
				0.2	0.3	0.4	0.5	0.6	0.7	0.8	0.9	1.0	
32	12	OUT	804	161	241	322	402	482	563	643	724	804	
		IN	691	138	207	276	346	415	484	553	622	691	
40	16	OUT	1257	251	377	503	629	754	880	1006	1131	1257	
		IN	1056	211	317	422	528	634	739	845	950	1056	
50	20	OUT	1963	393	589	785	982	1178	1374	1570	1767	1963	
		IN	1649	330	495	660	825	989	1154	1319	1484	1649	
63	20	OUT	3117	623	935	1247	1559	1870	2182	2494	2805	3117	
		IN	2803	561	841	1121	1402	1682	1962	2242	2523	2803	
80	25	OUT	5027	1005	1508	2011	2514	3016	3519	4022	4524	5027	
		IN	4536	907	1361	1814	2268	2722	3175	3629	4082	4536	
100	25	OUT	7854	1571	2356	3142	3927	4712	5498	6283	7068	7854	
		IN	7363	1473	2209	2945	3682	4418	5154	5890	6627	7363	

Note) Theoretical output (N) = Pressure (MPa) x Piston area (mm²)

Weights

(kg)

Bore size (mm)		32	40	50	63	80	100
Basic weight	Basic	0.43	0.64	1.09	1.42	2.32	3.15
	Foot	0.16	0.20	0.38	0.46	0.89	1.09
	Flange	0.20	0.23	0.47	0.58	1.30	1.81
	Single clevis	0.16	0.23	0.37	0.60	1.07	1.73
	Double clevis	0.20	0.32	0.45	0.71	1.28	2.11
	Trunnion	0.71	1.10	1.73	2.48	4.25	5.95
Additional weight per 50 mm of stroke	All mounting brackets	0.11	0.16	0.24	0.26	0.40	0.44
Accessories	Piston rod ball joint	0.07	0.11	0.22		0.40	
	Rod clevis	0.09	0.15	0.34		0.69	

Calculation: Example) **C96SD40-100C**

- Basic weight 0.64 (kg) (Basic, ø40)
- Additional weight 0.16 (kg/50 st)
- Cylinder stroke 100 (st)
- Mounting bracket weight 0.32 (kg) (Double clevis)

$$0.64 + 0.16 \times 100 \div 50 + 0.32 = 1.28 \text{ kg}$$

Allowable Kinetic Energy

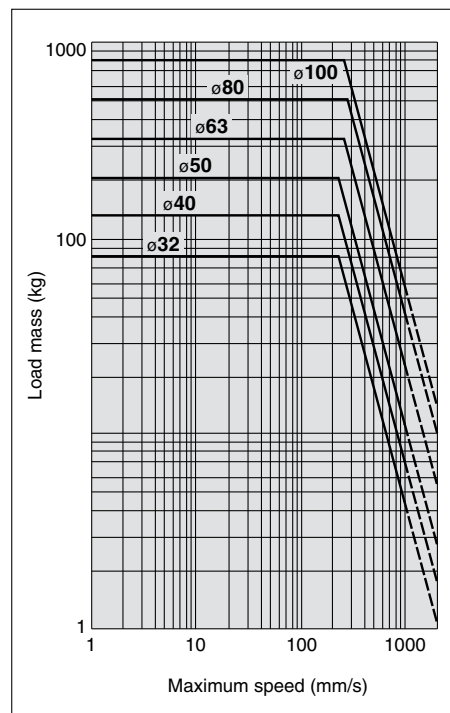

(Example) Find the upper limit of rod end load when an air cylinder of ø63 is operated at 500 mm/s. From a point indicating 500 mm/s on the axis of abscissas, extend a line upward and find a point where it intersects with a line for the 63 mm bore size. Extend a line from the intersection to the left and find a load mass 80 kg.

Construction

[First angle projection]

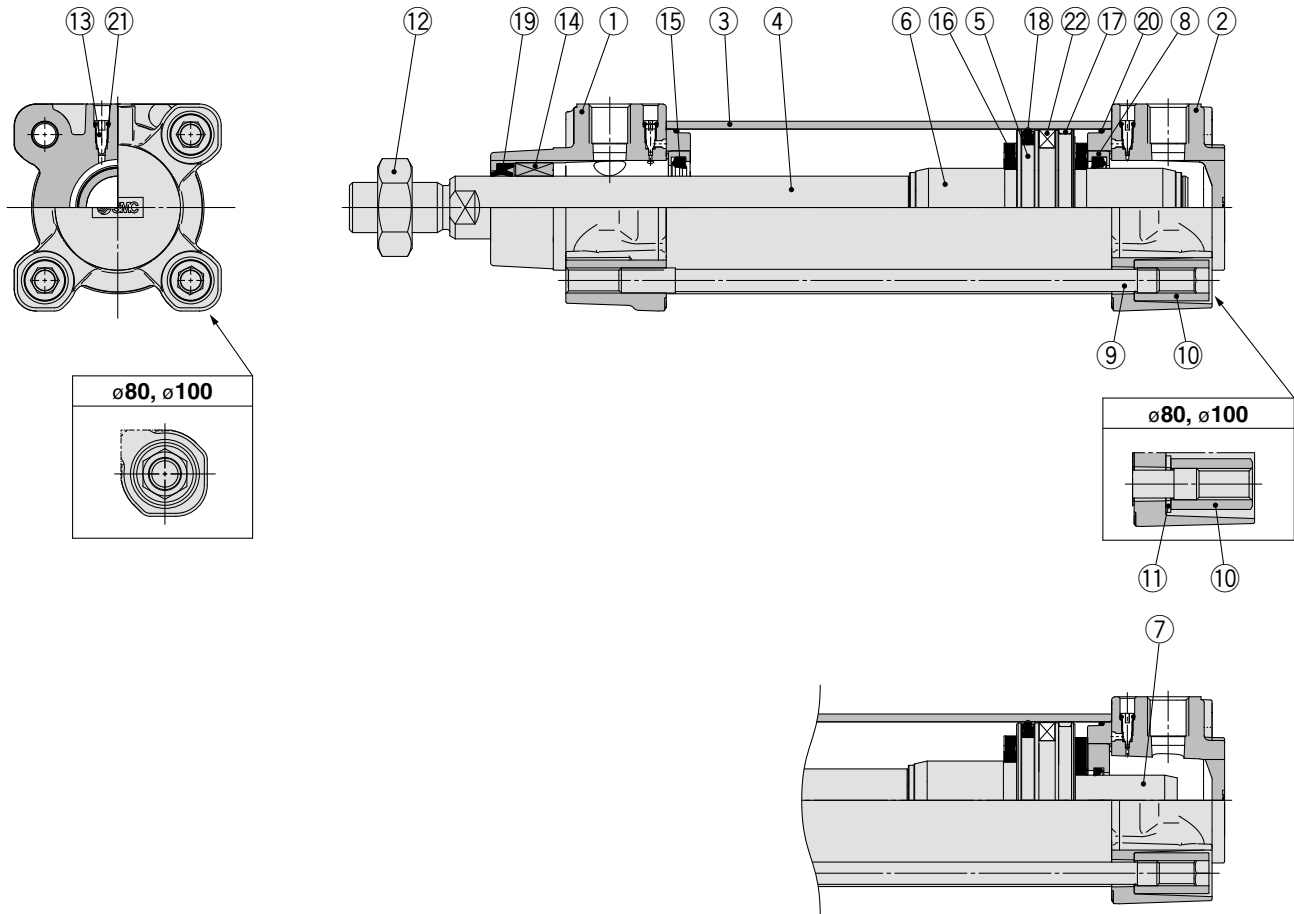

Component Parts

No.	Description	Material	Note
1	Rod cover	Aluminum die-cast	
2	Head cover	Aluminum die-cast	
3	Cylinder tube	Aluminum alloy	
4	Piston rod	Carbon steel	
5	Piston	Aluminum alloy	ø32 to ø63
		Aluminum die-cast	ø80, ø100
6	Cushion ring A	Aluminum alloy	
7	Cushion ring B	Aluminum alloy	
8	Cushion seal holder	Aluminum alloy	
9	Tie-rod	Carbon steel	
10	Tie-rod nut	Steel	
11	Flat washer	Steel	ø80, ø100
12	Rod end nut	Steel	
13	Cushion valve	Resin	
14	Bushing	Bearing alloy	
15	Cushion seal	Urethane	
16	Bumper	Urethane	
17	Wear ring	Resin	
18	Piston seal	NBR	
19	Rod seal	NBR	
20	Cylinder tube gasket	NBR	
21	Cushion valve seal	NBR	
22	Magnet		

Replacement Parts/Seal Kit (Single rod)

Bore size (mm)	Kit no.	Contents
32	CS95-32	Kits include items 15, 17, 18, 19, 20.
40	CS95-40	
50	CS95-50	
63	CS95-63	
80	CS95-80	
100	CS96-100	

* Seal kits consist of items 15, 17, 18, 19, 20 and can be ordered by using the seal kit number corresponding to each bore size.
* The seal kit includes a grease pack (10 g for ø32 to ø50, 20 g for ø63 and ø80, 30 g for ø100).

Order with the following part number when only the grease pack is needed.

Grease pack part number: GR-S-010 (10 g), GR-S-020 (20 g)

Series C96

Dimensions

[First angle projection]

Basic: C96S (D) B Bore size – Stroke C

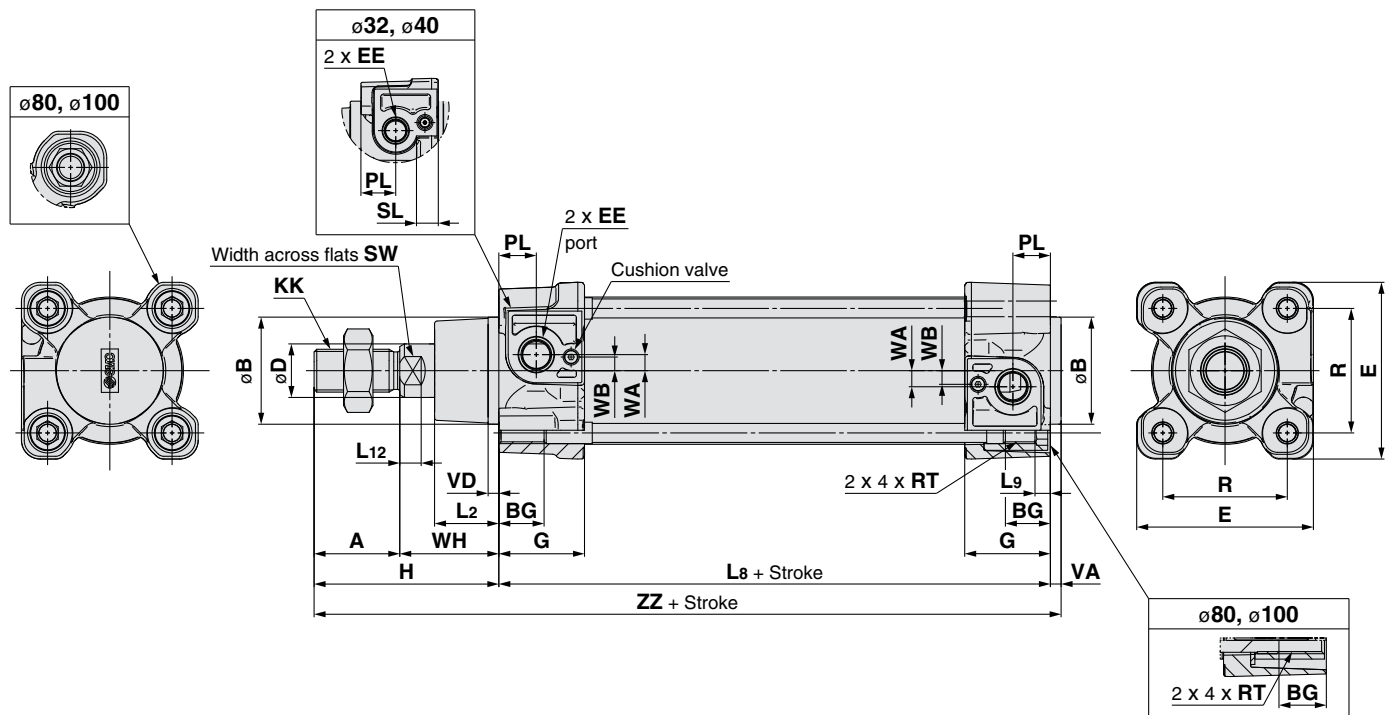

Bore size (mm)	Stroke range (mm)	A	ϕB d11	BG	ϕD	E	EE	G	H	KK	L2	L8	L9	L12	PL	R	RT	SL	SW	VA	VD	WA	WB	WH	ZZ
32	Up to 1000	22	30	16	12	47	G 1/8	28.9	48	M10 x 1.25	15	94	4	6	13	32.5	M6 x 1	8	10	4	4	4	7	26	146
40	Up to 1900	24	35	16	16	54	G 1/4	32.6	54	M12 x 1.25	17	105	4	6.5	14	38	M6 x 1	8	13	4	4	5	8.9	30	163
50	Up to 1900	32	40	16	20	66	G 1/4	32	69	M16 x 1.5	24	106	5	8	14	46.5	M8 x 1.25	—	17	4	4	6	5.1	37	179
63	Up to 1900	32	45	16	20	77	G 3/8	38.6	69	M16 x 1.5	24	121	5	8	16	56.5	M8 x 1.25	—	17	4	4	9	6.3	37	194
80	Up to 1900	40	45	17	25	99	G 3/8	38.4	86	M20 x 1.5	30	128	—	10	16	72	M10 x 1.5	—	22	4	4	11.5	6	46	218
100	Up to 1900	40	55	17	25	118	G 1/2	42.9	91	M20 x 1.5	32	138	—	10	18	89	M10 x 1.5	—	22	4	4	17	10	51	233

Dimensions

Axial foot (L)

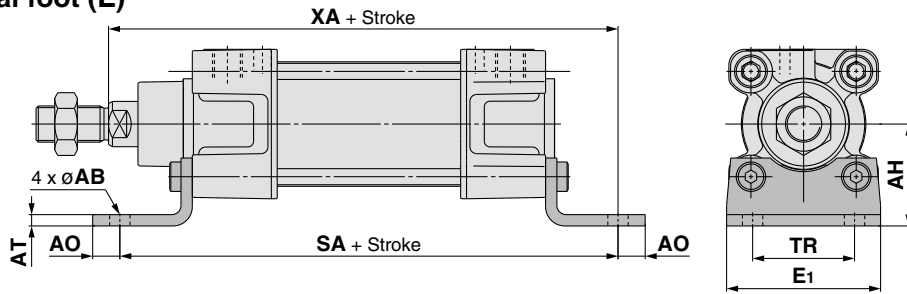

(mm)

Bore size (mm)	E1	TR	AH	AO	AT	AB	SA	XA
32	48	32	32	10	4.5	7	142	144
40	55	36	36	11	4.5	10	161	163
50	68	45	45	12	5.5	10	170	175
63	80	50	50	12	5.5	10	185	190
80	100	63	63	14	6.5	12	210	215
100	120	75	71	16	6.5	14.5	220	230

Center trunnion (T)

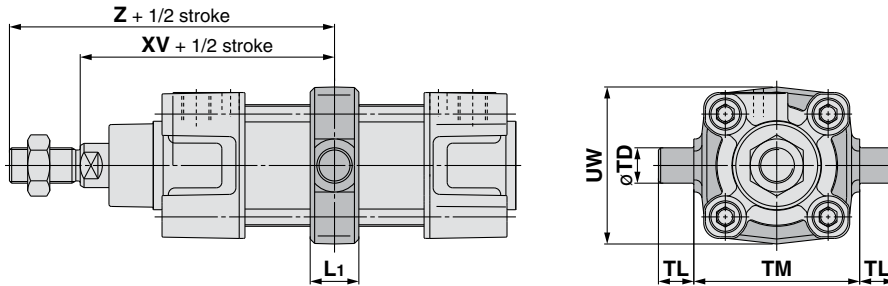

(mm)

Bore size (mm)	TM	TL	TD _{e8}	UW	L1	XV	Z
32	50	12	12	49	17	73	95
40	63	16	16	58	22	82.5	106.5
50	75	16	16	71	22	90	122
63	90	20	20	87	28	97.5	129.5
80	110	20	20	110	34	110	150
100	132	25	25	136	40	120	160

Rod flange (F)

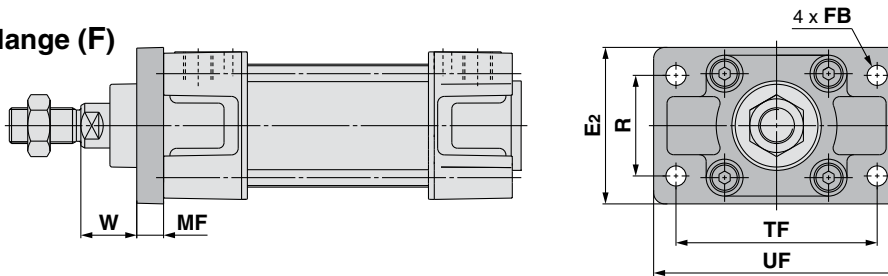

(mm)

Bore size (mm)	R	TF	FB	E2	UF	W	MF
32	32	64	7	50	79	16	10
40	36	72	9	55	90	20	10
50	45	90	9	70	110	25	12
63	50	100	9	80	120	25	12
80	63	126	12	100	153	30	16
100	75	150	14	120	178	35	16

Head flange (G)

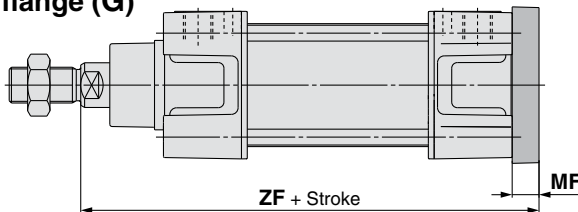

(mm)

Bore size (mm)	MF	ZF
32	10	130
40	10	145
50	12	155
63	12	170
80	16	190
100	16	205

**Single clevis (C)
Double clevis (D)**

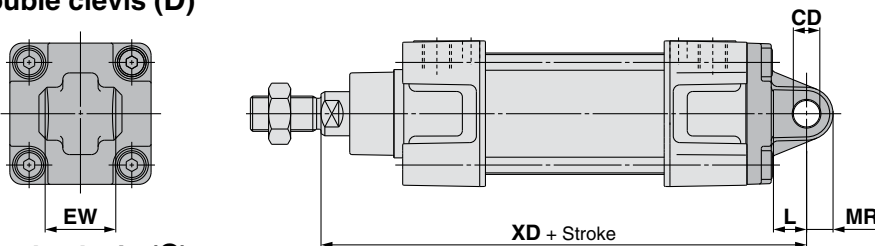

(mm)

Bore size (mm)	EW	CD _{H9}	L	MR	XD	UB _{h14}	CB _{H14}	EB
32	26 ^{-0.2} _{-0.6}	10	12	9.5	142	45	26	65
40	28 ^{-0.2} _{-0.6}	12	15	12	160	52	28	75
50	32 ^{-0.2} _{-0.6}	12	15	12	170	60	32	80
63	40 ^{-0.2} _{-0.6}	16	20	16	190	70	40	90
80	50 ^{-0.2} _{-0.6}	16	20	16	210	90	50	110
100	60 ^{-0.2} _{-0.6}	20	25	20	230	110	60	140

Single clevis (C)

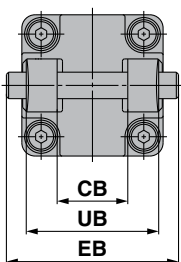

Double clevis (D)

Series C96

Accessories

Dimensions: Mounting Brackets

[First angle projection]

Axial foot (L)

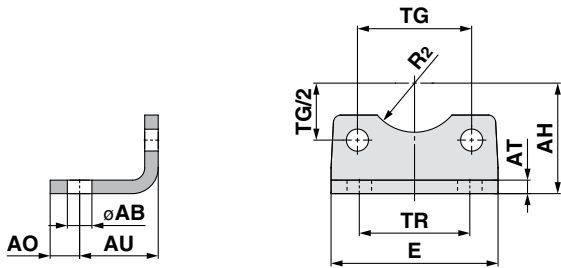

Bore size (mm)	Part no.	AB	TG _{±0.2}	E	TR	AO	AU	AH	AT	R2	Screw size
32	L5032	7	32.5	48	32	10	24	32	4.5	15	M6 x 16L
40	L5040	10	38	55	36	11	28	36	4.5	17.5	M6 x 16L
50	L5050	10	46.5	68	45	12	32	45	5.5	20	M8 x 20L
63	L5063	10	56.5	80	50	12	32	50	5.5	22.5	M8 x 20L
80	L5080	12	72	100	63	14	41	63	6.5	22.5	M10 x 20L
100	L5100	14.5	89	120	75	16	41	71	6.5	27.5	M10 x 20L

* Supplied with 4 mounting screws.

Flange (F, G)

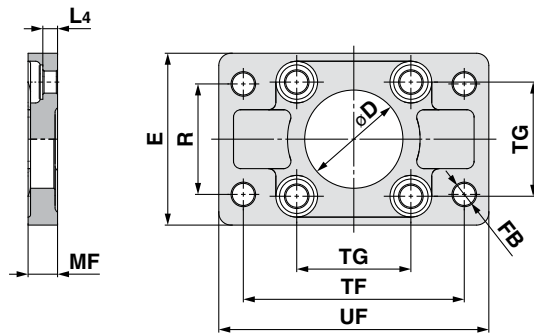

Bore size (mm)	Part no.	D _{H11}	øFB	TG _{±0.2}	E	R	MF	TF	UF	L4	Screw size
32	F5032	30	7	32.5	50	32	10	64	79	5	M6 x 20L
40	F5040	35	9	38	55	36	10	72	90	5	M6 x 20L
50	F5050	40	9	46.5	70	45	12	90	110	6.5	M8 x 20L
63	F5063	45	9	56.5	80	50	12	100	120	6.5	M8 x 20L
80	F5080	45	12	72	100	63	16	126	153	9	M10 x 25L
100	F5100	55	14	89	120	75	16	150	178	9	M10 x 25L

* Supplied with 4 mounting screws.

Single clevis (C)

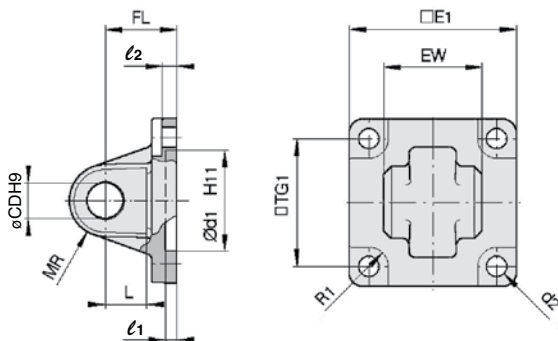

Bore size (mm)	Part no.	E ₁	EW	TG ₁	FL	l ₁	L	l ₂	ød ₁	øCD	MR	ød ₂	R ₁
32	C5032	45	26 ^{-0.2} _{-0.6}	32.5	22	5	12	5.5	30	10	9.5	6.6	6.5
40	C5040	51	28 ^{-0.2} _{-0.6}	38	25	5	15	5.5	35	12	12	6.6	6.5
50	C5050	64	32 ^{-0.2} _{-0.6}	46.5	27	5	15	6.5	40	12	12	9	8.5
63	C5063	74	40 ^{-0.2} _{-0.6}	56.5	32	5	20	6.5	45	16	16	9	8.5
80	C5080	94	50 ^{-0.2} _{-0.6}	72	36	5	20	10	45	16	16	11	11
100	C5100	113	60 ^{-0.2} _{-0.6}	89	41	5	25	10	55	20	20	11	12

* Supplied with 4 mounting screws.

Dimensions: Mounting Brackets, Pivot Brackets for Cylinder Mounting

[First angle projection]

Double clevis (D)

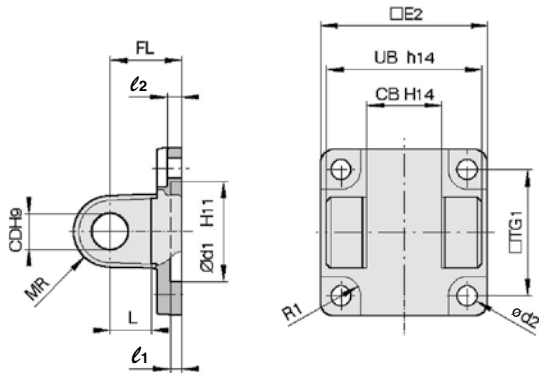

Bore size (mm)	Part no.	TG ₁	FL	l ₁	L	l ₂	ød ₁	øCD	MR	ød ₂	R ₁	E ₂	UB	CB
32	D5032	32.5	22	5	12	5.5	30	10	9.5	6.6	6.5	48	45	26
40	D5040	38	25	5	15	5.5	35	12	12	6.6	6.5	56	52	28
50	D5050	46.5	27	5	15	6.5	40	12	12	9	8.5	64	60	32
63	D5063	56.5	32	5	20	6.5	45	16	16	9	8.5	75	70	40
80	D5080	72	36	5	20	10	45	16	16	11	11	95	90	50
100	D5100	89	41	5	25	10	55	20	20	11	12	115	110	60

* Supplied with 4 mounting screws, clevis pin, and clevis pin bracket.

Clevis pivot bracket (E)

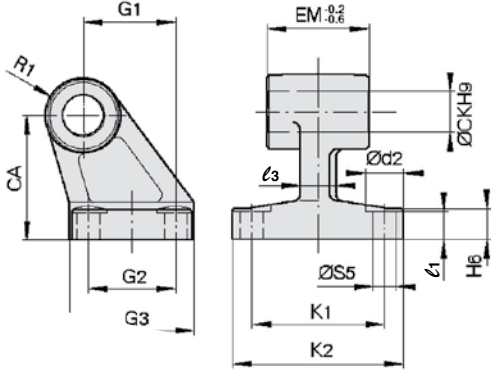

Bore size (mm)	Part no.	ød ₂	øCK	øS5	K ₁	K ₂ (Max.)	l ₃ (Max.)	G ₁	l ₁	G ₂	EM	G ₃ (Max.)	CA	H ₆	R ₁
32	E5032	11	10	6.6	38	51	10	21	7	18	26 ^{-0.2} _{-0.6}	31	32	8	10
40	E5040	11	12	6.6	41	54	10	24	9	22	28 ^{-0.2} _{-0.6}	35	36	10	11
50	E5050	15	12	9	50	65	12	33	11	30	32 ^{-0.2} _{-0.6}	45	45	12	12
63	E5063	15	16	9	52	67	14	37	11	35	40 ^{-0.2} _{-0.6}	50	50	12	15
80	E5080	18	16	11	66	86	18	47	12.5	40	50 ^{-0.2} _{-0.6}	60	63	14	15
100	E5100	18	20	11	76	96	20	55	13.5	50	60 ^{-0.2} _{-0.6}	70	71	15	19

Single clevis with ball joint (CS)

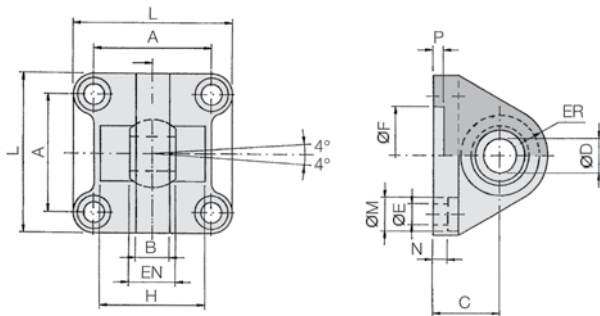

Bore size (mm)	Part no.	A	B (Max.)	C	øDH7	EN ₀ ^{-0.1}	ER (Max.)	øFH11	øE	L	øM	N	P	H _{±0.5}
32	CS5032	32.5	10.5	22	10	14	15	30	6.6	45	10.5	5.5	5	—
40	CS5040	38	12	25	12	16	18	35	6.6	55	11	5.5	5	—
50	CS5050	46.5	15	27	16	21	20	40	9	65	15	6.5	5	51
63	CS5063	56.5	15	32	16	21	23	45	9	75	15	6.5	5	—
80	CS5080	72	18	36	20	25	27	45	11	95	18	10	5	70
100	CS5100	89	18	41	20	25	30	55	11	115	18	10	5	—

* Supplied with 4 mounting screws.

Series C96

Dimensions: Pivot Brackets for Cylinder Mounting

[First angle projection]

Double clevis pivot bracket (DS)/for ES accessory

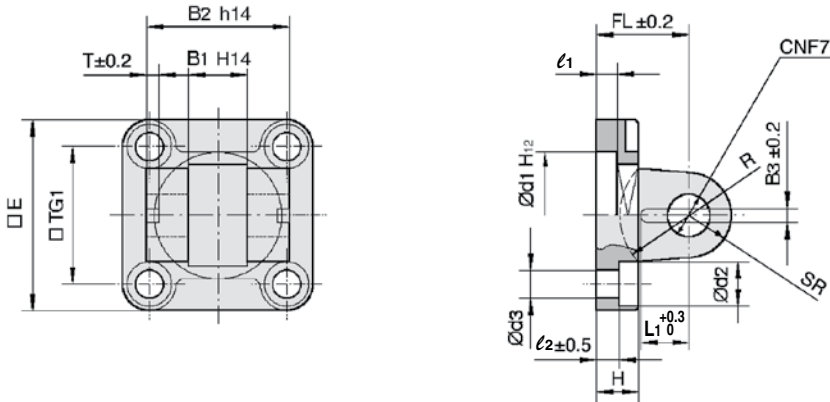

(mm)

Bore size (mm)	Part no.	E	B ₁	B ₂	B ₃	L ₁	TG ₁	T	l ₁ (Min.)	l ₂	FL	H (Max.)	Ød ₁	Ød ₂	Ød ₃	ØCN	SR (Max.)	R
32	DS5032	45	14	34	3.3	11.5	32.5	3	5	5.5	22	10	30	10.5	6.6	10	11	17
40	DS5040	55	16	40	4.3	12	38	4	5	5.5	25	10	35	11	6.6	12	13	20
50	DS5050	65	21	45	4.3	14	46.5	4	5	6.5	27	12	40	15	9	16	18	22
63	DS5063	75	21	51	4.3	14	56.5	4	5	6.5	32	12	45	15	9	16	18	25
80	DS5080	95	25	65	4.3	16	72	4	5	10	36	16	45	18	11	20	22	30
100	DS5100	115	25	75	6.3	16	89	4	5	10	41	16	55	18	11	20	22	32

* Supplied with 4 mounting screws, clevis pin, and clevis pin bracket.

Clevis pivot bracket with ball joint (ES)

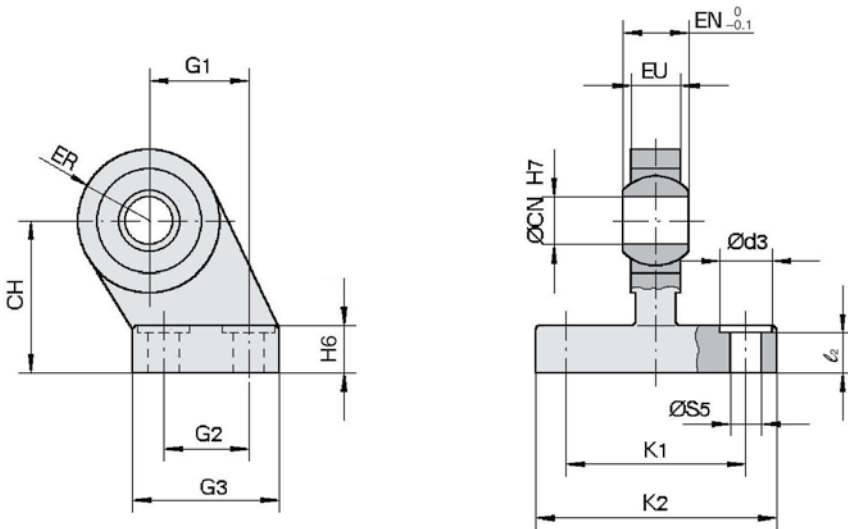

(mm)

Bore size (mm)	Part no.	Ød ₃	ØCN	ØS ₅	K ₁	K ₂ (Max.)	l ₂	G ₁	G ₂	G ₃ (Max.)	EN	EU	CH	H ₆	ER (Max.)
32	ES5032	11	10	6.6	38	51	8.5	21	18	31	14	10.5	32	10	15
40	ES5040	11	12	6.6	41	54	8.5	24	22	35	16	12	36	10	18
50	ES5050	15	16	9	50	65	10.5	33	30	45	21	15	45	12	20
63	ES5063	15	16	9	52	67	10.5	37	35	50	21	15	50	12	23
80	ES5080	18	20	11	66	86	11.5	47	40	60	25	18	63	14	27
100	ES5100	18	20	11	76	96	12.5	55	50	70	25	18	71	15	30

Dimensions: Piston Rod Accessories

[First angle projection]

Floating joint: JA

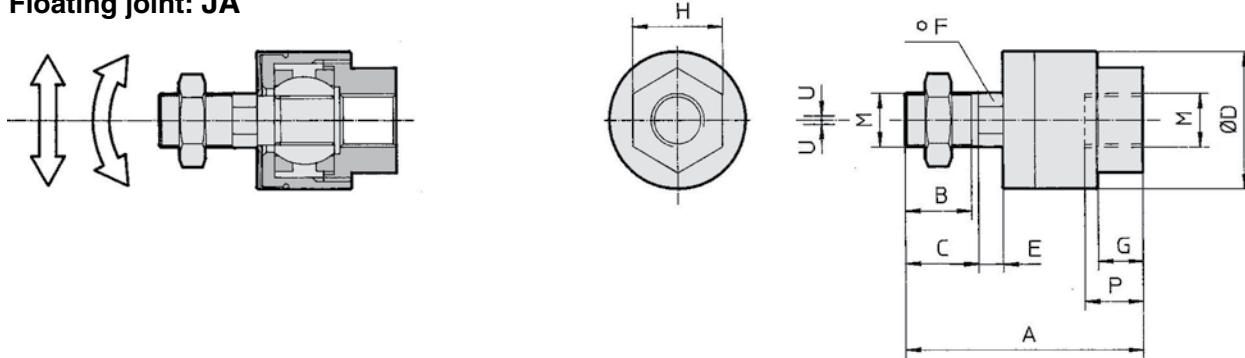

Bore size (mm)	Part no.	M	A	B	C	ØD	E	F	G	H	P	U	Load (kN)	Weight (g)	Angle
32	JA30-10-125	M10 x 1.25	49.5	19.5	—	24	5	8	8	17	9	0.5	2.5	70	±0.5°
40	JA40-12-125	M12 x 1.25	60	20	—	31	6	11	11	22	13	0.75	4.4	160	
50, 63	JA50-16-150	M16 x 1.5	71.5	22	—	41	7.5	14	13.5	27	15	1	11	300	
80, 100	JAH50-20-150	M20 x 1.5	101	28	31	59.5	11.5	24	16	32	18	2	18	1080	

* Black color

Rod clevis: GKM (ISO 8140)

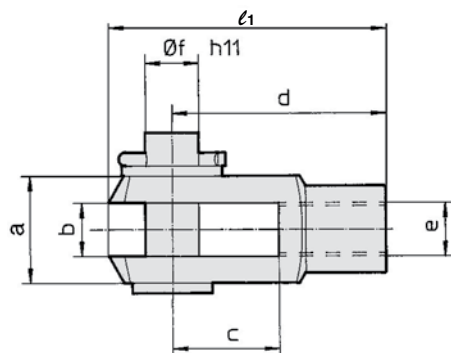

Bore size (mm)	Part no.	e	b	d	øf h11 (Shaft)	øf H9 (Hole)	l1	c (Min.)	a (Max.)
32	GKM10-20	M10 x 1.25	10 ^{+0.5} / _{+0.15}	40	10	10	52	20	20
40	GKM12-24	M12 x 1.25	12 ^{+0.5} / _{+0.15}	48	12	12	62	24	24
50, 63	GKM16-32	M16 x 1.5	16 ^{+0.5} / _{+0.15}	64	16	16	83	32	32
80, 100	GKM20-40	M20 x 1.5	20 ^{+0.5} / _{+0.15}	80	20	20	105	40	40

* Supplied with clevis pin and clevis pin bracket.

Piston rod ball joint: KJ (ISO 8139)

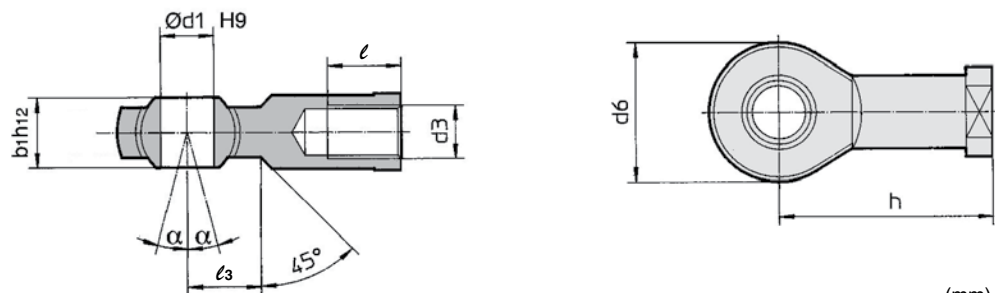

Bore size (mm)	Part no.	d3	ød1 H9	h	d6 (Max.)	b1 h12	l (Min.)	α	l3
32	KJ10D	M10 x 1.25	10	43	28	14	20	4°	15
40	KJ12D	M12 x 1.25	12	50	32	16	22	4°	17
50, 63	KJ16D	M16 x 1.5	16	64	42	21	28	4°	23
80, 100	KJ20D	M20 x 1.5	20	77	50	25	33	4°	27

Auto Switch Mounting

Minimum Stroke for Auto Switch Mounting

(mm)

Auto switch model	Number of auto switches	Support bracket other than center trunnion				
		ø32	ø40	ø50	ø63	ø80, ø100
D-M9□ D-M9□W	With 1 pc. With 2 pcs. (Different surfaces, Same surface)	10				
	With n pcs.	$10 + 40(n-2)/2$ $n = 2, 4, 6, 8...$				
D-M9□V D-M9□WV	With 1 pc. With 2 pcs. (Different surfaces, Same surface)	10				
	With n pcs.	$10 + 30(n-2)/2$ $n = 2, 4, 6, 8...$				
D-M9□A	With 1 pc. With 2 pcs. (Different surfaces, Same surface)	15	10			
	With n pcs.	$15 + 40(n-2)/2$ $n = 2, 4, 6, 8...$	$10 + 40(n-2)/2$ $n = 2, 4, 6, 8...$			
D-M9□AV	With 1 pc. With 2 pcs. (Different surfaces, Same surface)	10				
	With n pcs.	$10 + 30(n-2)/2$ $n = 2, 4, 6, 8...$				
D-A9□	With 1 pc. With 2 pcs. (Different surfaces, Same surface)	10				
	With n pcs.	$10 + 40(n-2)/2$ $n = 2, 4, 6, 8...$				
D-A9□V	With 1 pc. With 2 pcs. (Different surfaces, Same surface)	10				
	With n pcs.	$10 + 30(n-2)/2$ $n = 2, 4, 6, 8...$				
D-G39 D-K39 D-A3□	With 2 pcs. (Different surfaces)	35				
	With 2 pcs. (Same surface)	100				
	With n pcs. (Different surfaces)	$35 + 30(n-2)$ $n = 2, 3, 4...$				
	With n pcs. (Same surface)	$100 + 100(n-2)$ $n = 2, 3, 4...$				
D-A44	With 1 pc.	10				
	With 2 pcs. (Different surfaces)	35				
	With 2 pcs. (Same surface)	50				
	With n pcs. (Different surfaces)	$35 + 30(n-2)$ $n = 2, 3, 4...$				
	With n pcs. (Same surface)	$50 + 50(n-2)$ $n = 2, 3, 4...$				
D-A5□ D-A6□	With 1 pc. With 2 pcs. (Different surfaces, Same surface)	15			10	
	With n pcs. (Same surface)	$15 + 55(n-2)/2$ $n = 2, 4, 6, 8...$			$10 + 55(n-2)/2$ $n = 2, 4, 6, 8...$	
D-A59W	With 2 pcs. (Different surfaces, Same surface)	20			15	
	With n pcs. (Same surface)	$20 + 55(n-2)/2$ $n = 2, 4, 6, 8...$			$15 + 55(n-2)/2$ $n = 2, 4, 6, 8...$	
	With 1 pc.	15			25	
D-F5□ D-J5□ D-F5□W D-J59W D-F5BA D-F59F	With 2 pcs. (Different surfaces, Same surface)	15				
	With n pcs. (Same surface)	$15 + 55(n-2)/2$ $n = 2, 4, 6, 8...$				
	With 1 pc.	10				
D-F5NT	With 2 pcs. (Different surfaces, Same surface)	15			20	
	With n pcs. (Same surface)	$15 + 55(n-2)/2$ $n = 2, 4, 6, 8...$			$20 + 55(n-2)/2$ $n = 2, 4, 6, 8...$	
	With 1 pc.	10			20	
D-Y59□ D-Y7P D-Y7H D-Y7□W D-Z7□ D-Z80	With 1 pc. With 2 pcs. (Different surfaces, Same surface)	15	10			
	With n pcs.	$15 + 40(n-2)/2$ $n = 2, 4, 6, 8...$	$10 + 40(n-2)/2$ $n = 2, 4, 6, 8...$			
D-Y69□ D-Y7PV D-Y7□WV	With 1 pc. With 2 pcs. (Different surfaces, Same surface)	10				
	With n pcs.	$10 + 30(n-2)/2$ $n = 2, 4, 6, 8...$				
D-Y7BA	With 1 pc. With 2 pcs. (Different surfaces, Same surface)	20				
	With n pcs.	$20 + 45(n-2)/2$ $n = 2, 4, 6, 8...$				
D-P4DW	With 1 pc. With 2 pcs. (Different surfaces, Same surface)	15				
	With n pcs.	$15 + 65(n-2)/2$ $n = 2, 4, 6, 8...$				

Note) n = 3, 4, 5...

(mm)

Auto switch model	Number of auto switches	Center trunnion					
		ø32	ø40	ø50	ø63	ø80	ø100
D-M9□ D-M9□W	With 1 pc. With 2 pcs. (Different surfaces, Same surface)	75			85	90	95
	With n pcs.	$75 + 40(n-4)/2$ n = 4, 8, 12, 16...			$85 + 40(n-4)/2$ n = 4, 8, 12, 16...	$90 + 40(n-4)/2$ n = 4, 8, 12, 16...	$95 + 40(n-4)/2$ n = 4, 8, 12, 16...
D-M9□V D-M9□WV	With 1 pc. With 2 pcs. (Different surfaces, Same surface)	50	55		60	65	70
	With n pcs.	$50 + 30(n-4)/2$ n = 4, 8, 12, 16...	$55 + 30(n-4)/2$ n = 4, 8, 12, 16...		$60 + 30(n-4)/2$ n = 4, 8, 12, 16...	$65 + 30(n-4)/2$ n = 4, 8, 12, 16...	$70 + 30(n-4)/2$ n = 4, 8, 12, 16...
D-M9□A	With 1 pc. With 2 pcs. (Different surfaces, Same surface)	80			85	95	100
	With n pcs.	$80 + 40(n-2)/2$ n = 4, 8, 12, 16...			$85 + 40(n-2)/2$ n = 4, 8, 12, 16...	$95 + 40(n-2)/2$ n = 4, 8, 12, 16...	$100 + 40(n-2)/2$ n = 4, 8, 12, 16...
D-M9□AV	With 1 pc. With 2 pcs. (Different surfaces, Same surface)	55			65	70	75
	With n pcs.	$55 + 30(n-2)/2$ n = 4, 8, 12, 16...			$65 + 30(n-2)/2$ n = 4, 8, 12, 16...	$70 + 30(n-2)/2$ n = 4, 8, 12, 16...	$75 + 30(n-2)/2$ n = 4, 8, 12, 16...
D-A9□	With 1 pc. With 2 pcs. (Different surfaces, Same surface)	70	75		80	85	95
	With n pcs.	$70 + 40(n-4)/2$ n = 4, 8, 12, 16...	$75 + 40(n-4)/2$ n = 4, 8, 12, 16...		$80 + 40(n-4)/2$ n = 4, 8, 12, 16...	$85 + 40(n-4)/2$ n = 4, 8, 12, 16...	$95 + 40(n-4)/2$ n = 4, 8, 12, 16...
D-A9□V	With 1 pc. With 2 pcs. (Different surfaces, Same surface)	45	50		55	60	70
	With n pcs.	$45 + 30(n-4)/2$ n = 4, 8, 12, 16...	$50 + 30(n-4)/2$ n = 4, 8, 12, 16...		$55 + 30(n-4)/2$ n = 4, 8, 12, 16...	$60 + 30(n-4)/2$ n = 4, 8, 12, 16...	$70 + 30(n-4)/2$ n = 4, 8, 12, 16...
D-G39 D-K39 D-A3□	With 2 pcs. (Different surfaces)	60	65		75	80	85
	With 2 pcs. (Same surface)	90	95		100	105	110
	With n pcs. (Different surfaces)	$60 + 30(n-2)$ n = 2, 4, 6, 8...	$65 + 30(n-2)$ n = 2, 4, 6, 8...		$75 + 30(n-2)$ n = 2, 4, 6, 8...	$80 + 30(n-2)$ n = 2, 4, 6, 8...	$85 + 30(n-2)$ n = 2, 4, 6, 8...
	With n pcs. (Same surface)	$90 + 100(n-2)$ n = 2, 4, 6, 8...	$95 + 100(n-2)$ n = 2, 4, 6, 8...		$100 + 100(n-2)$ n = 2, 4, 6, 8...	$105 + 100(n-2)$ n = 2, 4, 6, 8...	$110 + 100(n-2)$ n = 2, 4, 6, 8...
D-A44	With 1 pc.	60	65		75	80	85
	With 2 pcs. (Different surfaces)	70			75	80	85
	With 2 pcs. (Same surface)	70			75	80	85
	With n pcs. (Different surfaces)	$70 + 30(n-2)$ n = 2, 4, 6, 8...			$75 + 30(n-2)$ n = 2, 4, 6, 8...	$80 + 30(n-2)$ n = 2, 4, 6, 8...	$85 + 30(n-2)$ n = 2, 4, 6, 8...
	With n pcs. (Same surface)	$70 + 50(n-2)$ n = 2, 4, 6, 8...			$75 + 50(n-2)$ n = 2, 4, 6, 8...	$80 + 50(n-2)$ n = 2, 4, 6, 8...	$85 + 50(n-2)$ n = 2, 4, 6, 8...
D-A5□ D-A6□	With 1 pc. With 2 pcs. (Different surfaces, Same surface)	60		80	95	105	110
	With n pcs. (Same surface)	$60 + 55(n-4)/2$ n = 4, 8, 12, 16...		$80 + 55(n-4)/2$ n = 4, 8, 12, 16...	$95 + 55(n-4)/2$ n = 4, 8, 12, 16...	$105 + 55(n-4)/2$ n = 4, 8, 12, 16...	$110 + 55(n-4)/2$ n = 4, 8, 12, 16...
D-A59W	With 2 pcs. (Different surfaces, Same surface)	60	70	85	105	110	115
	With n pcs. (Same surface)	$60 + 55(n-4)/2$ n = 4, 8, 12, 16...	$70 + 55(n-4)/2$ n = 4, 8, 12, 16...	$85 + 55(n-4)/2$ n = 4, 8, 12, 16...	$105 + 55(n-4)/2$ n = 4, 8, 12, 16...	$110 + 55(n-4)/2$ n = 4, 8, 12, 16...	$115 + 55(n-4)/2$ n = 4, 8, 12, 16...
	With 1 pc.	60	70	85	105	110	115
D-F5□ D-J5□ D-F5□W D-J59W D-F5BA D-F59F	With 2 pcs. (Different surfaces, Same surface)	90	95		100	110	115
	With n pcs. (Same surface)	$90 + 55(n-4)/2$ n = 4, 8, 12, 16...	$95 + 55(n-4)/2$ n = 4, 8, 12, 16...		$100 + 55(n-4)/2$ n = 4, 8, 12, 16...	$110 + 55(n-4)/2$ n = 4, 8, 12, 16...	$115 + 55(n-4)/2$ n = 4, 8, 12, 16...
	With 1 pc.	90	95		100	110	115
	With 2 pcs. (Different surfaces, Same surface)	100	105		110	120	125
D-F5NT	With n pcs. (Same surface)	$100 + 55(n-4)/2$ n = 4, 8, 12, 16...	$105 + 55(n-4)/2$ n = 4, 8, 12, 16...		$110 + 55(n-4)/2$ n = 4, 8, 12, 16...	$120 + 55(n-4)/2$ n = 4, 8, 12, 16...	$125 + 55(n-4)/2$ n = 4, 8, 12, 16...
	With 1 pc.	100	105		110	120	125
	With 1 pc. With 2 pcs. (Different surfaces, Same surface)	75	80		85	95	100
D-Y59□ D-Y7P D-Y7H D-Y7□W D-Z7□ D-Z80	With n pcs. (Same surface)	$75 + 40(n-4)/2$ n = 4, 8, 12, 16...	$80 + 40(n-4)/2$ n = 4, 8, 12, 16...		$85 + 40(n-4)/2$ n = 4, 8, 12, 16...	$95 + 40(n-4)/2$ n = 4, 8, 12, 16...	$100 + 40(n-4)/2$ n = 4, 8, 12, 16...
	With 1 pc. With 2 pcs. (Different surfaces, Same surface)	55			60	70	75
D-Y69□ D-Y7PV D-Y7□WV	With n pcs. (Same surface)	$55 + 30(n-4)/2$ n = 4, 8, 12, 16...			$60 + 30(n-4)/2$ n = 4, 8, 12, 16...	$70 + 30(n-4)/2$ n = 4, 8, 12, 16...	$75 + 30(n-4)/2$ n = 4, 8, 12, 16...
	With 1 pc. With 2 pcs. (Different surfaces, Same surface)	85	90		100	105	110
D-Y7BA	With n pcs. (Same surface)	$85 + 45(n-4)/2$ n = 4, 8, 12, 16...	$90 + 45(n-4)/2$ n = 4, 8, 12, 16...		$100 + 45(n-4)/2$ n = 4, 8, 12, 16...	$105 + 45(n-4)/2$ n = 4, 8, 12, 16...	$110 + 45(n-4)/2$ n = 4, 8, 12, 16...
	With 1 pc. With 2 pcs. (Different surfaces, Same surface)	110			115	125	130
D-P4DW	With n pcs. (Same surface)	$110 + 65(n-4)/2$ n = 4, 8, 12, 16...			$115 + 65(n-4)/2$ n = 4, 8, 12, 16...	$125 + 65(n-4)/2$ n = 4, 8, 12, 16...	$130 + 65(n-4)/2$ n = 4, 8, 12, 16...

Note) n = 3, 4, 5...

Series C96

Auto Switch Proper Mounting Position (Detection at stroke end) and Its Mounting Height

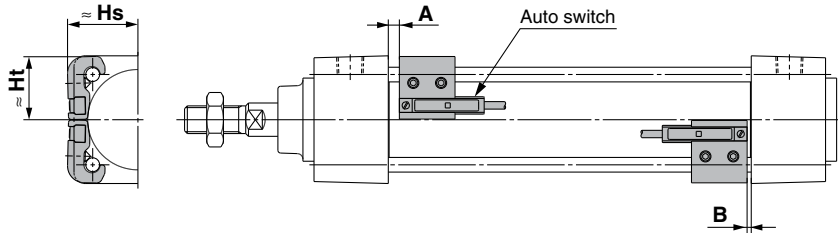

Auto Switch Proper Mounting Position

(mm)

Auto switch model	D-M9□ D-M9□V D-M9□A		D-A9□ D-A9□V		D-Y59 D-Y69 D-Y7P D-Y7H D-Y7□W D-Y7BA D-Z7□ D-Z80		D-P4DW		D-G39 D-K39 D-A3□ D-A44 D-A5□ D-A6□		D-F5□ D-J5□ D-F59F		D-J51		D-A59W		D-F5NT		
	A	B	A	B	A	B	A	B	A	B	A	B	A	B	A	B	A	B	
Bore size																			
32	14	10.5	10	6.5	7.5	4	7	3.5	4	0	10.5	7	10	6.5	8	4.5	15.5	12	
40	14	14	10	10	7.5	7.5	7	7	4	4	10.5	10.5	10	10	8	8	15.5	15.5	
50	15.5	14.5	11.5	10.5	9	8	8.5	7.5	5.5	4.5	12	11	11.5	10.5	9.5	8.5	17	16	
63	16.5	15.5	12.5	11.5	10	9	9.5	8.5	6.5	5.5	13	12	12.5	11.5	10.5	9.5	18	17	
80	21.5	18	17.5	14	15	11.5	14.5	11	11.5	8	18	14.5	17.5	14	15.5	12	23	19.5	
100	21.5	19	17.5	15	15	12.5	14.5	12	11.5	9	18	15.5	17.5	15	15.5	13	23	20.5	

Note) Adjust the auto switch after confirming the operating conditions in the actual setting.

Auto Switch Mounting Height

(mm)

Auto switch model	D-M9□ D-M9□W D-M9□A D-A9□		D-A9□V		D-M9□V D-M9□WV D-M9□AV		D-A5□ D-A6□ D-A59W		D-F5□ D-J5□ D-F59F D-F5□W D-J59W D-F5BA D-F5NT		D-G39 D-K39 D-A3□		D-A44		D-Y59□ D-Y7P D-Y7□W D-Y7BA D-Z7□ D-Z80		D-Y69□ D-Y7PV D-Y7□WV		D-P4DW	
	Hs	Ht	Hs	Ht	Hs	Ht	Hs	Ht	Hs	Ht	Hs	Ht	Hs	Ht	Hs	Ht	Hs	Ht	Hs	Ht
Bore size																				
32	24.5	23	27.5	23	30.5	23	35	24.5	32.5	25	67	27.5	77	27.5	25.5	23	26.5	23	38	31
40	28.5	25.5	31.5	25.5	34	25.5	38.5	27.5	36.5	27.5	71.5	27.5	81.5	27.5	29.5	26	30	26	42	33
50	33.5	31	36	31	38.5	31	43.5	34.5	41	34	77	—	87	—	33.5	31	34.5	31	46.5	39
63	38.5	36	40.5	36	43	36	48.5	39.5	46	39	83.5	—	93.5	—	39	36	40	36	51.5	44
80	46.5	45	49	45	52	45	55	46.5	52.5	46.5	92.5	—	103	—	47.5	45	48.5	45	58	51.5
100	54	53.5	57	53.5	59.5	53.5	62	55	59.5	55	103	—	113.5	—	55.5	53.5	56.5	53.5	65.5	60.5

Auto Switch Mounting Brackets/Part No.

Auto switch model	Bore size (mm)					
	ø32	ø40	ø50	ø63	ø80	ø100
D-M9□/M9□V D-M9□W/M9□WV D-M9□A/M9□AV D-A9□/A9□V	BMB5-032	BMB5-032	BA7-040	BA7-040	BA7-063	BA7-063
D-G39/K39 D-A3□/A44	BMB2-032	BMB2-040	BMB1-050	BMB1-063	BMB1-080	BMB1-100
D-F5□/J5□ D-F5□W/J59W D-F59F D-F5BA D-F5NT D-A5□/A6□ D-A59W	BT-03	BT-03	BT-05	BT-05	BT-06	BT-06
D-P4DW	BMB3T-040	BMB3T-040	BMB3T-050	BMB3T-050	BMB3T-080	BMB3T-080
D-Y59□/Y69□ D-Y7P/Y7PV D-Y7□W D-Y7□WV D-Y7BA D-Z7□/Z80	BMB4-032	BMB4-032	BMB4-050	BMB4-050	BA4-063	BA4-063

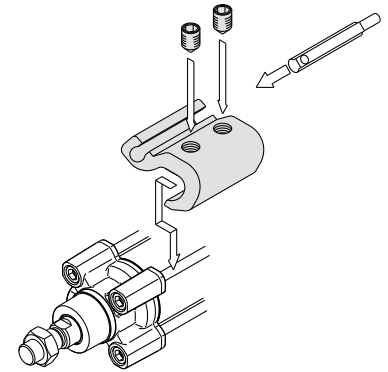

• Mounting example for D-A9□(V),

[Stainless Steel Mounting Screw]

The following stainless steel mounting screw kit (including set screws) is available. Use it in accordance with the operating environment. (Since the auto switch mounting bracket is not included, order it separately.)

BBA1: For D-A5/A6/F5/J5

Note 1) For details on BBA1, refer to page 20.

The D-F5BA auto switch is set on the cylinder with the stainless steel screws above when shipped from factory.

When only an auto switch is shipped independently, the BBA1 is attached.

Note 2) When using the D-M9□A(V) or Y7BA, please do not use the iron set screws included with the auto switch mounting bracket (BMB5-032, BA7-□□□, BMB4-□□□, BA4-□□□) shown above, instead order the set of stainless steel set screws (BBA1), and please use the stainless steel set screws (M4 x 6 L) included in BBA1.

Operating Range

Auto switch model	Bore size (mm)					
	32	40	50	63	80	100
D-M9□/M9□V D-M9□W/M9□WV D-M9□A/M9□AV	4	4.5	5	6	6	6
D-A9□/A9□V	7	7.5	8.5	9.5	9.5	10.5
D-Y59□/Y69□ D-Y7P/Y7□V D-Y7□W/Y7□WV D-Y7BA	5.5	5.5	7	7.5	6.5	5.5
D-Z7□/Z80	7.5	8.5	7.5	9.5	9.5	10.5
D-F5□/J5□ D-F5□W/J59W D-F5BA/F5NT D-F59F	3.5	4	4	4.5	4.5	4.5
D-A5□/A6□	9	9	10	11	11	11
D-A59W	13	13	13	14	14	15
D-G39/K39	9	9	9	10	10	11
D-A3□/A44	9	9	10	11	11	11
D-P4DW	4	4	4	4.5	4	4.5

* Values which include hysteresis are for guideline purposes only, they are not a guarantee (assuming approximately ±30% dispersion) and may change substantially depending on the ambient environment.

Series C96

Other than the applicable auto switches listed in “How to Order”, the following auto switches are mountable.

Refer to the **WEB catalog** or the Best Pneumatics No. 2 for the detailed specifications.

Type	Part no.	Electrical entry	Features	
Sold state	D-M9NV, M9PV, M9BV	Grommet (Perpendicular)	—	
	D-Y69A, Y69B, Y7PV		Diagnostic indication (2-color indication)	
	D-M9NWV, M9PWV, M9BWV			Water resistant (2-color indication)
	D-Y7NWV, Y7PWV, Y7BWV			
	D-M9NAV, M9PAV, M9BAV		Grommet (In-line)	—
	D-Y59A, Y59B, Y7P	Diagnostic indication (2-color indication)		
	D-F59, F5P, J59			Water resistant (2-color indication)
	D-Y7NW, Y7PW, Y7BW	With timer		
	D-F59W, F5PW, J59W			Magnetic field resistant (2-color indication)
	D-F5BA, Y7BA			
	D-F5NT			
	D-P5DW			
	Reed	D-A93V, A96V	Grommet (Perpendicular)	—
D-A90V		Grommet (In-line)	Without indicator light	
D-A67, Z80				
D-A53, A56, Z73, Z76			—	

* Normally closed (NC = b contact) solid state auto switches (D-F9G/F9H/Y7G/Y7H) are also available.

For details, refer to the **WEB catalog** or the Best Pneumatics No. 2.

* With pre-wired connector is also available for solid state auto switches. For details, refer to the **WEB catalog** or the Best Pneumatics No. 2.

How to Mount and Move the Auto Switch

Mounting Bracket Tie-rod Mounting Type

<Applicable Auto Switch>

Solid state switch ... D-G39, D-K39

Reed switch D-A33, D-A34, D-A44

How to Mount and Move the Auto Switch

D-A3□, D-G3/K3 type

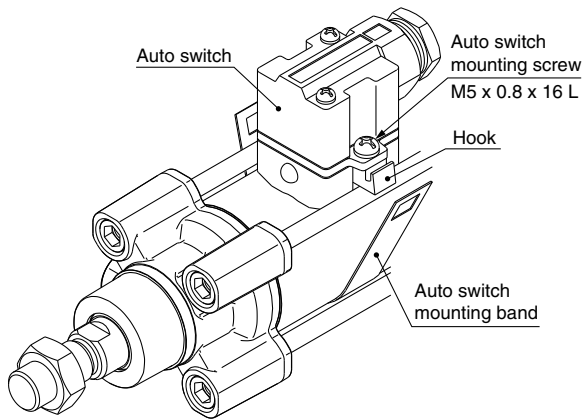

D-A44 type

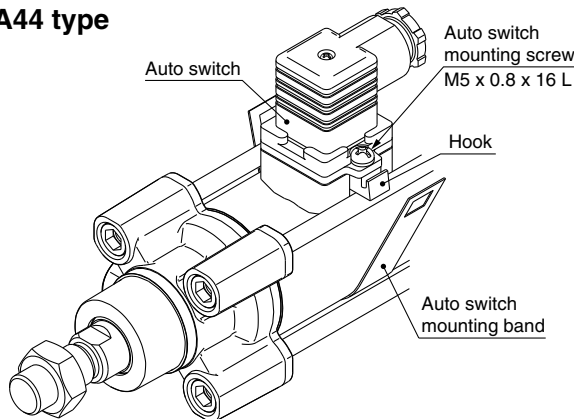

1. Loosen the auto switch mounting screws at both sides to pull down the hook.
2. Put an auto switch mounting band on the cylinder tube and set it at the auto switch mounting position, and then hook the band.
3. Screw lightly the auto switch mounting screw (M5 x 0.8 x 16 L).
4. Set the whole body to the detecting position by sliding, tighten the mounting screw (M5 x 0.8 x 16 L) to secure the auto switch. (The tightening torque should be about 1.5 to 2.2 lbf-ft (2 to 3 N-m).)
5. When changing the detecting position, carry out in the state of 3.

Auto Switch Mounting Bracket Part No. (Band)

Cylinder series	Applicable bore size (mm)					
	32	40	50	63	80	100
C96	BMB2-032	BMB2-040	BMB1-050	BMB1-063	BMB1-080	BMB1-100

<Applicable Auto Switch>

Solid state switch ... D-M9N(V), D-M9P(V), D-M9B(V)

D-M9NW(V), D-M9PW(V), D-M9BW(V)

D-M9NA(V), D-M9PA(V), D-M9BA(V)

Reed switch D-A90(V), A93(V), A96(V)

How to Mount and Move the Auto Switch

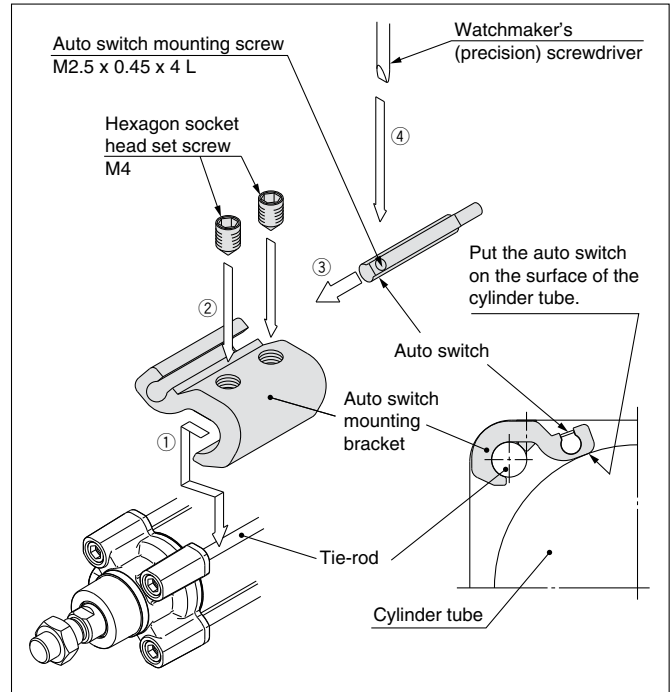

1. Fix it to the detecting position with a set screw by installing an auto switch mounting bracket in cylinder tie-rod and letting the bottom surface of an auto switch mounting bracket contact the cylinder tube firmly.
2. Fix it to the detecting position with a set screw (M4). (Use a hexagon wrench.)
3. Fit an auto switch into the auto switch mounting groove to set it roughly to the mounting position for an auto switch.
4. After confirming the detecting position, tighten up the mounting screw (M2.5 x 0.45 x 4 L) attached to an auto switch, and secure the auto switch.
5. When changing the detecting position, carry out in the state of 3.

Note 1) To protect auto switches, ensure that main body of an auto switch should be embedded into auto switch mounting groove with a depth of 15 mm or more.

Note 2) Set the tightening torque of a hexagon socket head set screw (M4) to be 0.74 to 0.89 lbf-ft (1.0 to 1.2 N-m).

Note 3) When tightening an auto switch mounting screw (M2.5), use a watchmaker's screwdriver with a grip diameter of 5 to 6 mm. Also, set the tightening torque to be 0.04 to 0.11 lbf-ft (0.05 to 0.15 N-m). As a guide, turn 90° from the position where it comes to feel tight.

Auto Switch Mounting Bracket Part No. (Including Bracket, Set Screw)

Cylinder series	Applicable bore size (mm)					
	32	40	50	63	80	100
C96	BMB5-032	BMB5-032	BA7-040	BA7-040	BA7-063	BA7-063

Note 1) When using the D-M9□A(V), please order stainless steel screw set BBA1 separately (page 20), and use the stainless steel set screws, after selecting set screws of the appropriate length for the cylinder series—as shown in the table above.

Note 2) Color or gloss differences in the metal surfaces have no effect on metal performance. The special properties of the chromate (trivalent) applied to the main body of the auto switch mounting bracket for BA7□ and BMB5□ result in differences in coloration depending on the production lot, but these have no adverse impact on corrosion resistance.

Mounting Bracket Tie-rod Mounting Type

<Applicable Auto Switch>

Solid state switch ... D-Y59^A_B, Y69^A_B, D-Y7P(V)
 D-Y7NW(V), Y7PW(V), Y7BW(V)
 D-Y7BA
 Reed switch D-Z73, Z76, Z80

How to Mount and Move the Auto Switch

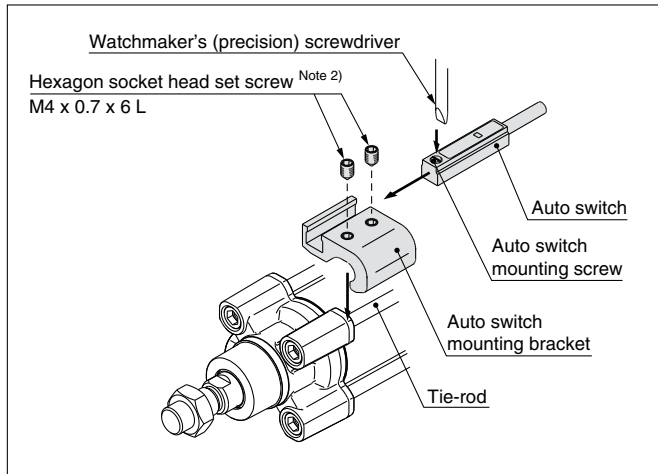

Note 1) When tightening an auto switch mounting screw, use a watchmaker's screwdriver with a handle diameter of 5 to 6 mm. Also, set the tightening torque to be 0.04 to 0.07 lbf-ft (0.05 to 0.1 N-m).
As a guide, turn 90° from the position where it comes to feel tight. Set the tightening torque of a hexagon socket head set screw (M4 x 0.7 x 6 L) to be 0.74 to 0.89 lbf-ft (1.0 to 1.2 N-m).

1. Fix it to the detecting position with a set screw by installing an auto switch mounting bracket in cylinder tie-rod and letting the bottom surface of an auto switch mounting bracket contact the cylinder tube firmly. (Use a hexagon wrench.)
 2. Fit an auto switch into the auto switch mounting groove to set it roughly to the mounting position for an auto switch.
 3. After confirming the detecting position, tighten up the mounting screw attached to an auto switch, and secure the auto switch.
 4. When changing the detecting position, carry out in the state of 2.
- * To protect auto switches, ensure that main body of an auto switch should be embedded into auto switch mounting groove with a depth of 15 mm or more.

Auto Switch Mounting Bracket Part No. (Including Bracket, Set Screw)

Cylinder series	Applicable bore size (mm)					
	32	40	50	63	80	100
C96	BMB4-032	BMB4-032	BMB4-050	BMB4-050	BA4-063	BA4-063

Note 2) When using the D-Y7BA, please order stainless steel screw set BBA1 separately (page 20), and use the stainless steel set screws, after selecting set screws of the appropriate length for the cylinder series — as shown in the table above.

<Applicable Auto Switch>

Solid state switch ... D-P4DW

How to Mount and Move the Auto Switch

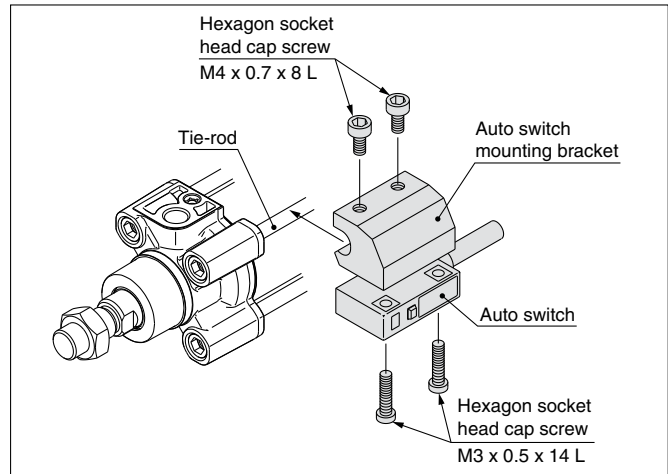

1. Slightly screw the hexagon socket head cap screw (M4 x 0.7 x 8 L) into the M4 tapped portion of auto switch mounting bracket. (2 locations) Use caution that the tip of the hexagon socket head cap screw should not stick out to the concave portion of auto switch mounting bracket.
2. Put a hexagon socket head cap screw (M3 x 0.5 x 14 L) through the auto switch's through-hole (2 locations), and then push it down into the M3 tapped part on the auto switch mounting bracket while turning it lightly.
3. Place the concave part of the auto switch mounting bracket into the cylinder tie-rod, and slide the auto switch mounting bracket in order to set roughly to the detecting position.
4. After reconfirming the detecting position, tighten the M3 mounting screw to secure the auto switch by making the bottom face of auto switch attached to the cylinder tube. (Tightening torque of M3 screw should be 0.37 to 0.52 lbf-ft (0.5 to 0.7 N-m).)
5. Tighten up M4 screw of auto switch mounting bracket to secure the auto switch mounting bracket. (Ensure that tightening torque of M4 screw should be set 0.74 to 0.89 lbf-ft (1.0 to 1.2 N-m).)

Auto Switch Mounting Bracket Part No. (Including Bracket, Screw)

Cylinder series	Applicable bore size (mm)					
	32	40	50	63	80	100
C96	BMB3T-040	BMB3T-040	BMB3T-050	BMB3T-050	BMB3T-080	BMB3T-080

Mounting Bracket Tie-rod Mounting Type

<Applicable Auto Switch>

Solid state switch ... D-F59, D-F5P

D-J59, D-J51, D-F5BA

D-F59W, D-F5PW, D-J59W

D-F59F, D-F5NT

Reed switch D-A53, D-A54, D-A56, D-A64, D-A67

D-A59W

1. Fix the auto switch on the auto switch mounting bracket with the auto switch mounting screw (M4) and install the set screw (M4).
2. Fit the auto switch mounting bracket into the cylinder tie-rod and then fix the auto switch at the detecting position with a set screw (M4).
(Be sure to put the auto switch on the surface of cylinder tube.) (Use a hexagon wrench.)
3. When changing the detecting position, loosen the set screw to move the auto switch and then re-fix the auto switch on the cylinder tube. (Tightening torque of M4 screw should be 0.74 to 0.89 lbf-ft (1.0 to 1.2 N-m).)

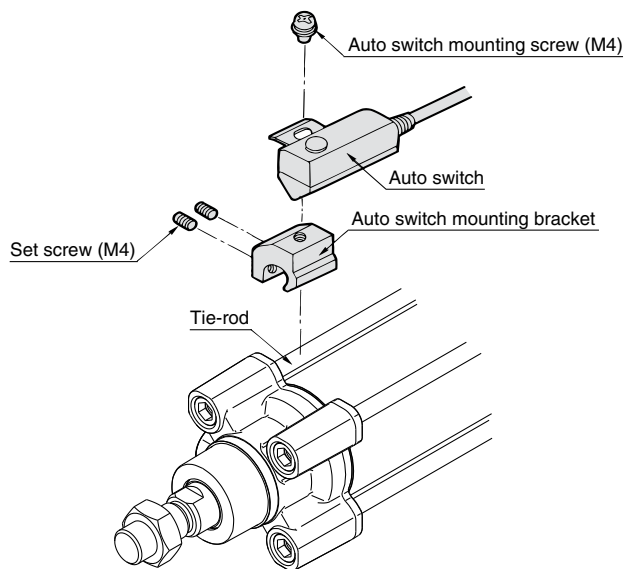

Auto Switch Mounting Bracket Part No. (Including Bracket, Screw, Set Screw)

Cylinder series	Applicable bore size (mm)					
	32	40	50	63	80	100
C96	BT-03	BT-03	BT-05	BT-05	BT-06	BT-06

The following stainless steel mounting screw kit (including set screws) is available. Use it in accordance with the operating environment. (Since the auto switch mounting bracket is not included, order it separately.)

BBA1: For D-A5/A6/F5/J5

The D-F5BA auto switch is set on the cylinder with the stainless steel screws above when shipped from factory.

When only an auto switch is shipped independently, the BBA1 is attached.

Stainless Steel Mounting Screw Set

Part no.	Contents				Applicable auto switch mounting bracket part no.	Applicable auto switch
	No.	Description	Size	Q'ty		
BBA1	1	Auto switch mounting screw	M4 x 0.7 x 8 L	1	BT-□□	D-A5, A6 D-F5, J5
	2	Set screw	M4 x 0.7 x 6 L	2	BT-03, BT-04, BT-05 BT-06, BT-08, BT-12	D-Z7, Z8 D-Y5, Y6, Y7
					BMB5-032 BA7-040, BA7-063, BA7-080	D-A9 D-M9
					BT-16, BT-18A, BT-20	D-A5, A6 D-F5, J5
	3	Set screw	M4 x 0.7 x 8 L	2	BS4-125, BS4-160 BS4-180, BS4-200	D-Z7, Z8 D-Y5, Y6, Y7
					BS5-125, BS5-160 BS5-180, BS5-200	D-A9 D-M9

Note) Use the set screw after selecting the appropriate length for the auto switch mounting bracket.

(Example) When using the BA7-040, select the 6 L type. 8 L type is not required.

Prior to Use

Auto Switch Connection and Example

Sink Input Specifications

3-wire, NPN

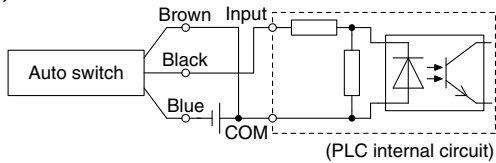

2-wire

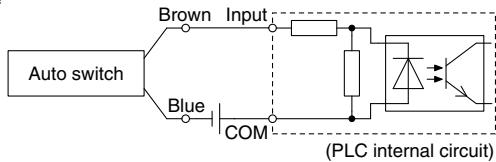

Source Input Specifications

3-wire, PNP

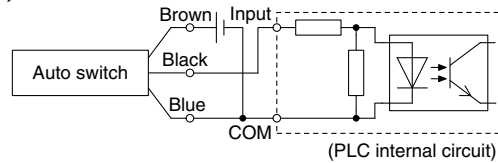

2-wire

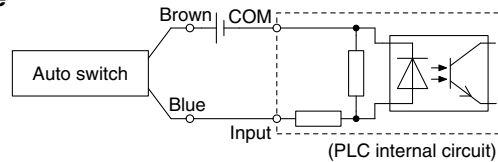

Connect according to the applicable PLC input specifications, as the connection method will vary depending on the PLC input specifications.

Example of AND (Series) and OR (Parallel) Connection

* When using solid state auto switches, ensure the application is set up so the signals for the first 50 ms are invalid.

3-wire AND connection for NPN output

(Using relays)

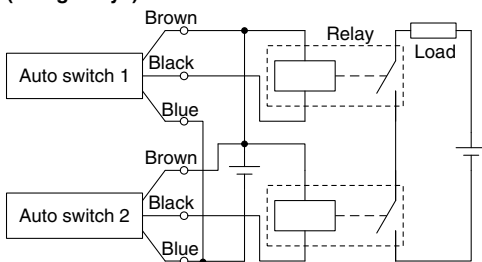

(Performed with auto switches only)

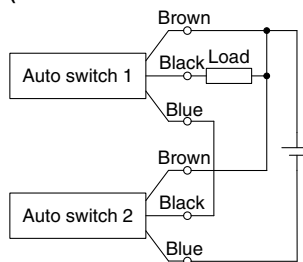

3-wire OR connection for NPN output

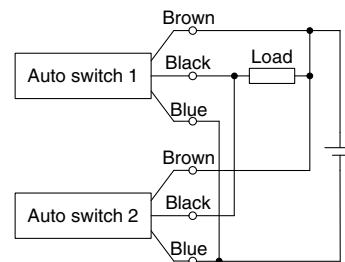

3-wire AND connection for PNP output

(Using relays)

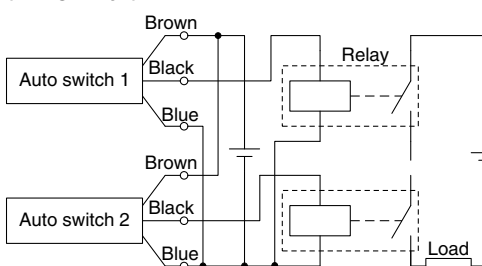

(Performed with auto switches only)

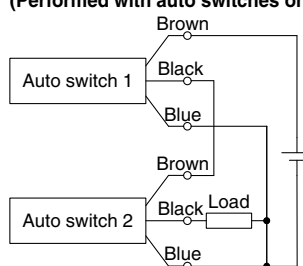

3-wire OR connection for PNP output

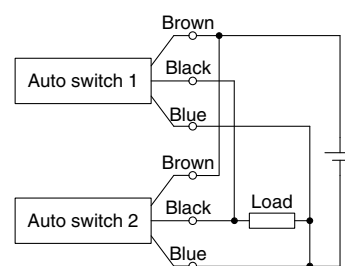

2-wire AND connection

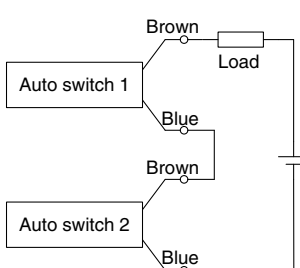

When two auto switches are connected in series, a load may malfunction because the load voltage will decline when in the ON state. The indicator lights will light up when both of the auto switches are in the ON state. Auto switches with load voltage less than 20 V cannot be used.

$$\begin{aligned} \text{Load voltage at ON} &= \text{Power supply voltage} - \text{Residual voltage} \times 2 \text{ pcs.} \\ &= 24 \text{ V} - 4 \text{ V} \times 2 \text{ pcs.} \\ &= 16 \text{ V} \end{aligned}$$

Example: Power supply is 24 VDC
Internal voltage drop in auto switch is 4 V.

2-wire OR connection

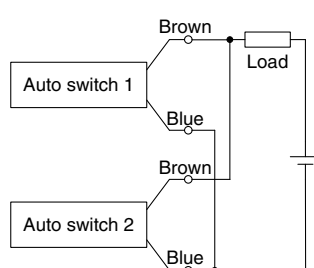

(Solid state)
When two auto switches are connected in parallel, malfunction may occur because the load voltage will increase when in the OFF state.

(Reed)
Because there is no current leakage, the load voltage will not increase when turned OFF. However, depending on the number of auto switches in the ON state, the indicator lights may sometimes grow dim or not light up, due to the dispersion and reduction of the current flowing to the auto switches.

$$\begin{aligned} \text{Load voltage at OFF} &= \text{Leakage current} \times 2 \text{ pcs.} \times \text{Load impedance} \\ &= 1 \text{ mA} \times 2 \text{ pcs.} \times 3 \text{ k}\Omega \\ &= 6 \text{ V} \end{aligned}$$

Example: Load impedance is 3 k Ω .
Leakage current from auto switch is 1 mA.

Series C96

Specific Product Precautions

Be sure to read this before handling. Refer to the back cover for Safety Instructions.
For Actuator and Auto Switch Precautions, refer to “Handling Precautions for SMC Products”
and the Operation Manual on SMC website, <http://www.smcworld.com>

Adjustment

Warning

1. Do not open the cushion valve more than the allowable number of rotations (following table).

Although the cushion valve is caulked as a retaining mechanism, do not open the cushion valve more than the allowable number of rotations. If air is supplied and operation started without confirming the above condition, the cushion valve may be ejected from the cover.

The allowable number of rotations refers to the number of rotations until the restrictor of the cushion valve is completely opened from the completely closed state.

2. Keep the screwing torque and the unscrewing torque of the cushion valve to the allowable torque or below (following table).

If a screwing torque or unscrewing torque beyond the allowable torque is applied, the valve will be damaged when the valve is closed completely or exceeds the retaining mechanism when the valve is opened completely, which will dislocate the engagement of the screw and eject the valve.

Bore size (mm)	Cushion valve width across flats	Hexagon wrench	Allowable number of rotations	Allowable torque lbf-ft (N·m)
32, 40	2	JIS 4648 Hexagon wrench key2	4	0.015 (0.02)
50, 63	2	JIS 4648 Hexagon wrench key2	4.5	0.015 (0.02)
80, 100	3	JIS 4648 Hexagon wrench key3	5.5	0.044 (0.06)

3. Be certain to activate the air cushion at the stroke end.

When the air cushion is inactivated, if the allowable kinetic energy exceeds the value on page 5, the piston rod assembly or the tie-rod may be damaged. Set the air cushion to valid when operating the cylinder.

Caution

1. When replacing brackets, use the hexagon wrenches shown below.

Bore size (mm)	Width across flats	Tightening torque
32, 40	4	3.5 lbf-ft (4.8 N·m)
50, 63	5	7.7 lbf-ft (10.4 N·m)
80, 100	6	13.4 lbf-ft (18.2 N·m)

Safety Instructions

These safety instructions are intended to prevent hazardous situations and/or equipment damage. These instructions indicate the level of potential hazard with the labels of “**Caution**,” “**Warning**” or “**Danger**.” They are all important notes for safety and must be followed in addition to International Standards (ISO/IEC)*1), and other safety regulations.

 **Caution:** **Caution** indicates a hazard with a low level of risk which, if not avoided, could result in minor or moderate injury.

 **Warning:** **Warning** indicates a hazard with a medium level of risk which, if not avoided, could result in death or serious injury.

 **Danger:** **Danger** indicates a hazard with a high level of risk which, if not avoided, will result in death or serious injury.

- *1) ISO 4414: Pneumatic fluid power – General rules relating to systems.
ISO 4413: Hydraulic fluid power – General rules relating to systems.
IEC 60204-1: Safety of machinery – Electrical equipment of machines.
(Part 1: General requirements)
ISO 10218-1: Manipulating industrial robots – Safety.
etc.

Warning

1. The compatibility of the product is the responsibility of the person who designs the equipment or decides its specifications.

Since the product specified here is used under various operating conditions, its compatibility with specific equipment must be decided by the person who designs the equipment or decides its specifications based on necessary analysis and test results. The expected performance and safety assurance of the equipment will be the responsibility of the person who has determined its compatibility with the product. This person should also continuously review all specifications of the product referring to its latest catalog information, with a view to giving due consideration to any possibility of equipment failure when configuring the equipment.

2. Only personnel with appropriate training should operate machinery and equipment.

The product specified here may become unsafe if handled incorrectly. The assembly, operation and maintenance of machines or equipment including our products must be performed by an operator who is appropriately trained and experienced.

3. Do not service or attempt to remove product and machinery/equipment until safety is confirmed.

1. The inspection and maintenance of machinery/equipment should only be performed after measures to prevent falling or runaway of the driven objects have been confirmed.
2. When the product is to be removed, confirm that the safety measures as mentioned above are implemented and the power from any appropriate source is cut, and read and understand the specific product precautions of all relevant products carefully.
3. Before machinery/equipment is restarted, take measures to prevent unexpected operation and malfunction.

4. Contact SMC beforehand and take special consideration of safety measures if the product is to be used in any of the following conditions.

1. Conditions and environments outside of the given specifications, or use outdoors or in a place exposed to direct sunlight.
2. Installation on equipment in conjunction with atomic energy, railways, air navigation, space, shipping, vehicles, military, medical treatment, combustion and recreation, or equipment in contact with food and beverages, emergency stop circuits, clutch and brake circuits in press applications, safety equipment or other applications unsuitable for the standard specifications described in the product catalog.
3. An application which could have negative effects on people, property, or animals requiring special safety analysis.
4. Use in an interlock circuit, which requires the provision of double interlock for possible failure by using a mechanical protective function, and periodical checks to confirm proper operation.

Caution

1. The product is provided for use in manufacturing industries.

The product herein described is basically provided for peaceful use in manufacturing industries.

If considering using the product in other industries, consult SMC beforehand and exchange specifications or a contract if necessary.

If anything is unclear, contact your nearest sales branch.

Limited warranty and Disclaimer/ Compliance Requirements

The product used is subject to the following “Limited warranty and Disclaimer” and “Compliance Requirements”.

Read and accept them before using the product.

Limited warranty and Disclaimer

1. The warranty period of the product is 1 year in service or 1.5 years after the product is delivered, whichever is first.*2)
Also, the product may have specified durability, running distance or replacement parts. Please consult your nearest sales branch.
2. For any failure or damage reported within the warranty period which is clearly our responsibility, a replacement product or necessary parts will be provided.
This limited warranty applies only to our product independently, and not to any other damage incurred due to the failure of the product.
3. Prior to using SMC products, please read and understand the warranty terms and disclaimers noted in the specified catalog for the particular products.

*2) **Vacuum pads are excluded from this 1 year warranty.**

A vacuum pad is a consumable part, so it is warranted for a year after it is delivered.
Also, even within the warranty period, the wear of a product due to the use of the vacuum pad or failure due to the deterioration of rubber material are not covered by the limited warranty.

Compliance Requirements

1. The use of SMC products with production equipment for the manufacture of weapons of mass destruction (WMD) or any other weapon is strictly prohibited.
2. The exports of SMC products or technology from one country to another are governed by the relevant security laws and regulations of the countries involved in the transaction. Prior to the shipment of a SMC product to another country, assure that all local rules governing that export are known and followed.

Caution

SMC products are not intended for use as instruments for legal metrology.

Measurement instruments that SMC manufactures or sells have not been qualified by type approval tests relevant to the metrology (measurement) laws of each country. Therefore, SMC products cannot be used for business or certification ordained by the metrology (measurement) laws of each country.

Safety Instructions

Be sure to read “Handling Precautions for SMC Products” (M-E03-3) before using.

SMC Corporation of America
10100 SMC Blvd., Noblesville, IN 46060
www.smcusa.com

SMC Pneumatics (Canada) Ltd.
www.smc Pneumatics.ca

(800) SMC.SMC1 (762-7621)
e-mail: sales@smcusa.com
International inquiries: www.smcworld.com

