

New

RoHS

# Lightweight and Compact Type Floating Joint

**Compact**

Model	Connection thread	Shortened dimensions	Overall length
JT20	M8 x 1.25	12.3 mm	27.2 mm
JT32	M10 x 1.25	13.0 mm	33.0 mm
JT40	M14 x 1.5	19 mm	43.0 mm



New JT Series

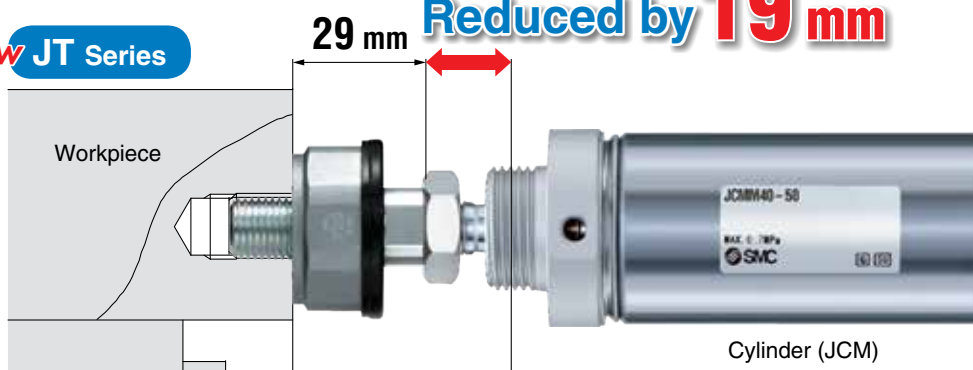

JA Series

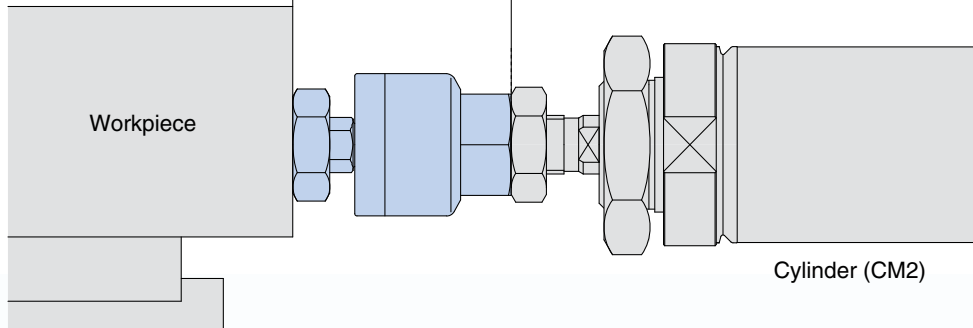

Max. **Weight 56% lighter**  
 50 g → 22 g (Compared to JA20)

Size	JA Series	New JT Series
20	50 g	22 g
32	70 g	38 g
40	160 g	98 g

- Screw size is the same as the screw size for standard JA series.
- Applicable for space saving cylinder (JCM series)
- With dustproof cover

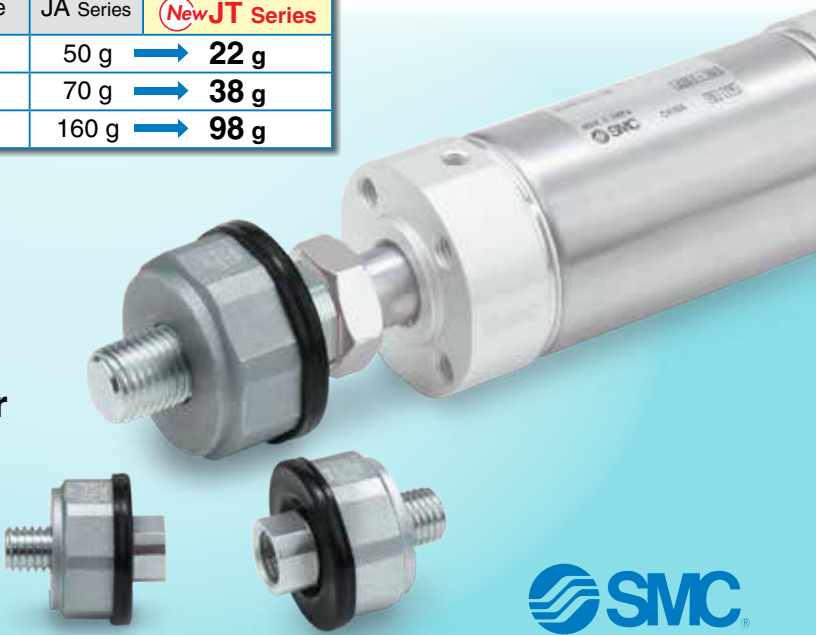

## JT Series

## Floating Joint *JT Series*

More compact and light-weight combination are available by using the JT series with a JCM series cylinder.

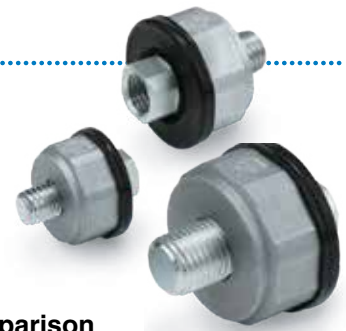

Reduction of length when using JT and JCM

**Max. 77 mm**

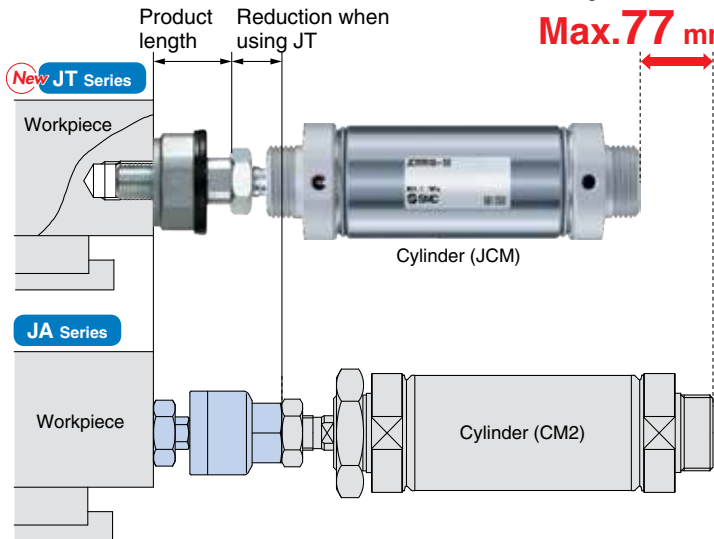







### Overall Length Comparison

Size	JA + CM2 Series	New JT + JCM Series	Reduction rate
20	139.5 mm	90.2 mm	35%
32	149.0 mm	96.0 mm	36%
40	189.0 mm	112.0 mm	41%

### Weight Comparison

Size	JA + CM2 Series	New JT + JCM Series	Reduction rate
20	190 g	102 g	46%
32	350 g	188 g	46%
40	720 g	378 g	48%

## Series Variations

Series	Supply pressure for cylinder		Applicable cylinder bore size [mm]	Mounting	Page
<b>JT Series</b> (Lightweight and compact type) 	Pneumatic cylinder	102 psi [0.7 MPa] or less	20, 25, 32, 40	Basic	Page 2 of this catalog
<b>JC Series</b> (Light weight type for light load) 	Pneumatic cylinder	145 psi [1 MPa] or less	20, 25, 32, 40, 50, 63	Basic	Refer to the <b>Web Catalog</b> or Best Pneumatics.
<b>JA Series</b> (Standard) 	Pneumatic cylinder	102psi [0.7 MPa] or less 145 psi [1 MPa] or less	6, 10, 15 20, 25, 32, 40, 50, 63, 80, 100, 125 140, 160, (180, 200)	Basic, Foot, Flange	
	Hydraulic cylinder	507 psi [3.5 MPa] or less	20, 25, 32, 40, 50, 63, 80, 100, 125 140, 160, (180, 200)		
<b>JAH Series</b> (Heavy load) 	Hydraulic cylinder	1015 psi [7 MPa] or less	40, 50, 63, 80, 100	Basic, Foot, Flange	
<b>JB Series</b> (For compact cylinders) 	Pneumatic cylinder	145 psi [1 MPa] or less	12, 16, 20, 25, 32, 40 50, 63, 80, 100	Basic (Female thread)	
<b>JS Series</b> (Stainless steel type) 	Pneumatic cylinder	145 psi [1 MPa] or less	10, 16, 20, 25, 32, 40 50, 63, (80, 100)	Basic	
	Hydraulic cylinder	508 psi [3.5 MPa] or less	20, 25, 32, 40, 50, 63		

( ) Available as special product

# Standard/Lightweight and Compact Type Floating Joint

# JT Series



## Specifications

Model	Nominal thread size	Allowable axial force lbf [N]	Allowable eccentricity U [mm]	Rotating angle [°]	Operating temperature range
JT20	M8 x 1.25	49.5 [220]	0.5	±2	14 to 158°F [-10 to 70°C]
JT32	M10 x 1.25	126 [560]	0.5	±2	
JT40	M14 x 1.5	198 [880]	0.75	±2	

### Operating range

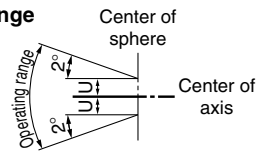

## Applicable Cylinder

Model	Applicable cylinder *1		Recommended cylinder
	Bore size	Operating pressure	
JT20	ø20	102 psi [0.7 MPa] or less	JC□M20 (Rod end male thread type)
JT32	ø25		JC□M25 (Rod end male thread type)
	ø32		JC□M32 (Rod end male thread type)
JT40	ø40		JC□M40 (Rod end male thread type)

\*1: Make sure to use a cylinder with a built-in cushion mechanism.

## How to Order

### JT 20

Size	Applicable cylinder	Nominal thread size
20	For ø20	M8 x 1.25
32	For ø25	M10 x 1.25
	For ø32	M10 x 1.25
40	For ø40	M14 x 1.5

## Operating Conditions

Operating pressure	Pneumatic cylinder: 102 psi [0.7 MPa] or less
Mounting	Basic
Operating temperature	14 to 158°F [-10 to 70°C]

# JT Series

## Construction

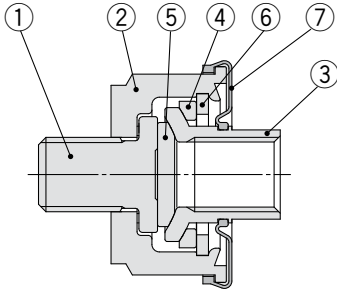

No.	Description	Material	Note
1	Stud	Carbon steel	Zinc chromated
2	Bowl	Aluminum alloy	Chromated
3	Socket	Carbon steel	Zinc chromated
4	Ring	Rolled steel	Nitriding treatment
5	Slider	Rolled steel	Nitriding treatment
6	Plate	Rolled steel	Zinc chromated
7	Dust cover	Synthetic rubber	

### Replacement Part

No.	Description	Part no.	Applicable model
7	Dust cover	P215420-07	For JT20
		P215432-07	For JT32
		P215440-07	For JT40

## Dimensions

### JT20 to 40

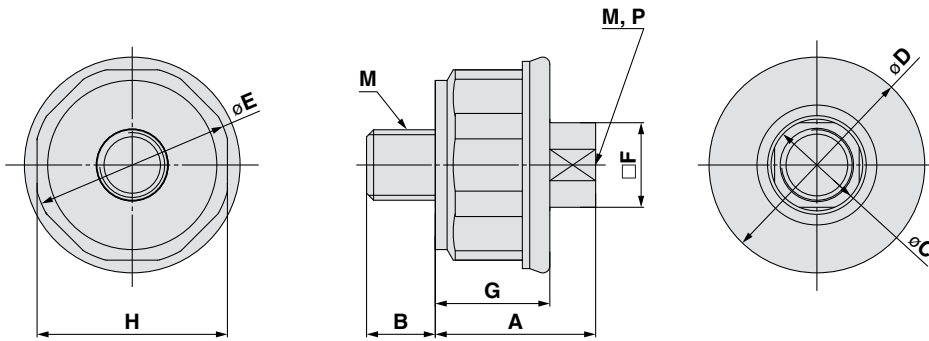
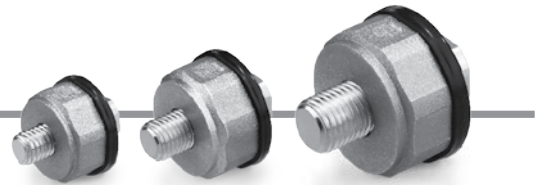

**Standard** Pneumatic: Up to 102 psi [0.7 MPa]

[mm]

Model	Connection thread M	A	B	øC	øD	øE	□F	G	Width across flats H	Maximum thread depth P	Weight
JT20	M8 x 1.25	19.2	8	11	(25.4)	23	10	13.6	22	9.5	22 g
JT32	M10 x 1.25	23	10	13.4	(30.6)	28	12	16.3	27	11.5	38 g
JT40	M14 x 1.5	29	14	19	(40.4)	37.4	17	20.3	36	15.5	98 g

\*: Value in ( ) is the dimension when the dust cover is used.



# JT Series

## Specific Product Precautions 1

Be sure to read this before handling the products. Refer to the back cover for Safety Instructions. For Actuator Precautions, refer to Handling Precautions for SMC Products and the Operation Manual on the SMC website, <http://www.smcworld.com>

### Design

#### ⚠ Warning

##### 1. Check the application.

This product is a shaft coupling for linear reciprocating motion used to absorb slight misalignment of the workpiece and the cylinder during linear motion. It is not a shaft coupling for rotation. Do not use it for an application in which rotation or oscillation is applied.

##### 2. Use a foot type or flange type bracket to mount a cylinder.

If a clevis type or trunnion type bracket is used, the cylinder shaft will not be fixed and it will be able to rotate. This mounting method, which exceeds the allowable eccentricity and rotating angle of the floating joint, may cause breakage or malfunction of the product.

##### 3. Use within the range of specifications.

Operation of the product under loading or with eccentricity outside of allowable specification may cause breakage or malfunction.

##### 4. Use a cylinder with a built-in cushion mechanism.

When a driven object is stopped, ensure the impact force of the object being transferred to the floating joint is prevented by using a cylinder with a built-in cushion mechanism (rubber cushion or air cushion).

To stop the cylinder at the intermediate position, use an external shock absorbing mechanism such as a shock absorber. If the cushion mechanism or the external shock absorbing mechanism is not used, an excessive impact force will be generated when stopping the cylinder and this may cause breakage or malfunction of the product.

##### 5. Install an external stopper to avoid run-away of the equipment.

If there is a risk of equipment damage or injury in the case of equipment running out of control or dropping off the driven object due to loose connecting screws, install an external stopper to avoid run-away of the equipment.

##### 6. Play in the axial direction

The JT series has play in the axial direction. (Default: 0.15 mm or less) When positioning the driven object, avoid the influence of play using a knock pin or external stopper.

### Mounting

#### ⚠ Warning

##### 1. Maintenance space

Allow sufficient space for maintenance and inspection.

##### 2. Operate the socket by hand before mounting to ensure it moves smoothly.

The dust cover may stick to the socket. Move the dust cover at the base of the socket with fingers, or twist the socket right and left gently to free it before mounting.

### Mounting

#### ⚠ Warning

##### 3. Tighten the product to the appropriate torque for the screw size using an appropriate tool. In addition, apply a locking adhesive.

When connecting the driven object to the cylinder rod with a floating joint, hold the octagonal and square parts with an appropriate wrench and tighten the floating joint to the appropriate tightening torque. Refer to the table on the right for the appropriate tightening torque.

The floating joint may be broken or malfunction if parts other than the octagonal or square parts are gripped and rotated with pliers or a wrench, or if it is tightened to an excessive torque. As a countermeasure against loosening caused by vibration or other reasons, apply locking adhesive.

#### Wrench Size and Tightening Torque

Model	Stud (Male thread side)		Socket (Female thread side)	
	Wrench size (Bowl)	Tightening torque lbf-ft [N·m]	Wrench size (Socket)	Tightening torque lbf-ft [N·m]
JT20	Width: 22	9 [12]	Width: 10	6 to 9 [8 to 12]
JT32	Width: 27	18 [24]	Width: 12	11 to 18 [15 to 24]
JT40	Width: 36	50 [68]	Width: 17	30 to 50 [40 to 68]

#### Reference drawing for correct mounting

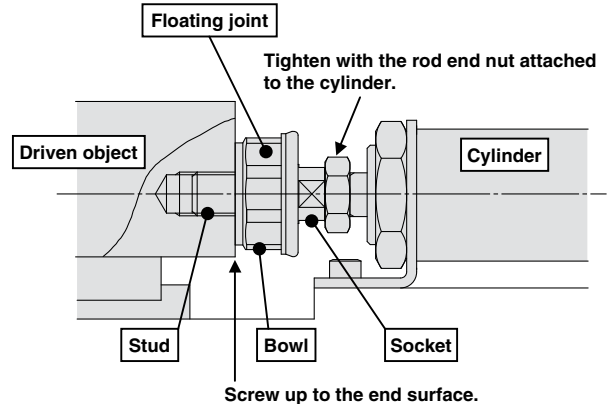

### Operating Environment

#### ⚠ Warning

##### 1. Avoid using in a location where the product could be splashed by liquids such as coolants and water. Also, avoid locations where exposed to a large amount of dust or foreign matter.

If liquid or dust gets inside the floating joint from the gap of the dust cover, it may cause a malfunction. Install a protective cover if the product is directly splashed by liquids or foreign matter can be accumulated.

##### 2. Do not expose the product to direct sunlight for an extended period of time.



## JT Series

# Specific Product Precautions 2

Be sure to read this before handling the products. Refer to the back cover for Safety Instructions. For Actuator Precautions, refer to Handling Precautions for SMC Products and the Operation Manual on the SMC website, <http://www.smcworld.com>

### Operation

#### Warning

- 1. Use the product so that the kinetic energy does not exceed the allowable value of the cylinder.**

The JC□M series cylinder is recommended to be used with the JT series. When operating the equipment, adjust the stroke end velocity according to the load so that the kinetic energy is no more than that of the allowable value of the cylinder.

Speed when stopping (stroke end velocity)  $\approx$  Average speed  $\times$  1.4

Also, when using cylinders or equipment other than the JC□M series, adjust the stroke end velocity according to the load so that the kinetic energy is no more than that of the allowable value of the JC□M series.

### Maintenance

#### Warning

- 1. Implement regular inspections as necessary when starting-up etc. Confirm that there is no loosening of the connection between the driven object and the cylinder.**

When the equipment is operated at high frequency, screws and play in the axial direction can increase and occur easily over time. Make sure to inspect the equipment before starting work to confirm that the screws have not been loosened and the play has not significantly increased.

- 2. If the play in the axial direction becomes larger or abnormal operation is found, replace the product.**

Play in the axial direction of the floating joint will increase over time, even if the product is used constantly. If the amount of play becomes excessive to the application or the operation is inflexible, replace the product itself.

- 3. Confirm that there is no weakening of the rubber bumper within the cylinder or adjustment error of the air cushion.**

If the rubber bumper of the cylinder is weakened or the adjustment of the air cushion is incorrect, an excessive impact force will be generated when the cylinder reaches its end of stroke, this may cause breakage or malfunction of the product. Replace the cylinder if the rubber bumper is weakening or readjust the air cushion if an adjustment error is found.

### Other

#### Caution

- 1. Chromate treatment is performed for the bowl of JT series for rust prevention. There may be slight variation in the evenness and tone of color, but this does not affect the resistance against rust or product performance.**

If the product with even tone of color is required for the application, it is available as a special request. Please contact SMC.



## Safety Instructions

These safety instructions are intended to prevent hazardous situations and/or equipment damage. These instructions indicate the level of potential hazard with the labels of “**Caution**,” “**Warning**” or “**Danger**.” They are all important notes for safety and must be followed in addition to International Standards (ISO/IEC)\*1), and other safety regulations.

 **Caution:** **Caution** indicates a hazard with a low level of risk which, if not avoided, could result in minor or moderate injury.

 **Warning:** **Warning** indicates a hazard with a medium level of risk which, if not avoided, could result in death or serious injury.

 **Danger:** **Danger** indicates a hazard with a high level of risk which, if not avoided, will result in death or serious injury.

\*1) ISO 4414: Pneumatic fluid power – General rules relating to systems.  
ISO 4413: Hydraulic fluid power – General rules relating to systems.  
IEC 60204-1: Safety of machinery – Electrical equipment of machines.  
(Part 1: General requirements)  
ISO 10218-1: Manipulating industrial robots – Safety.  
etc.

### Warning

#### 1. The compatibility of the product is the responsibility of the person who designs the equipment or decides its specifications.

Since the product specified here is used under various operating conditions, its compatibility with specific equipment must be decided by the person who designs the equipment or decides its specifications based on necessary analysis and test results. The expected performance and safety assurance of the equipment will be the responsibility of the person who has determined its compatibility with the product. This person should also continuously review all specifications of the product referring to its latest catalog information, with a view to giving due consideration to any possibility of equipment failure when configuring the equipment.

#### 2. Only personnel with appropriate training should operate machinery and equipment.

The product specified here may become unsafe if handled incorrectly. The assembly, operation and maintenance of machines or equipment including our products must be performed by an operator who is appropriately trained and experienced.

#### 3. Do not service or attempt to remove product and machinery/equipment until safety is confirmed.

1. The inspection and maintenance of machinery/equipment should only be performed after measures to prevent falling or runaway of the driven objects have been confirmed.
2. When the product is to be removed, confirm that the safety measures as mentioned above are implemented and the power from any appropriate source is cut, and read and understand the specific product precautions of all relevant products carefully.
3. Before machinery/equipment is restarted, take measures to prevent unexpected operation and malfunction.

#### 4. Contact SMC beforehand and take special consideration of safety measures if the product is to be used in any of the following conditions.

1. Conditions and environments outside of the given specifications, or use outdoors or in a place exposed to direct sunlight.
2. Installation on equipment in conjunction with atomic energy, railways, air navigation, space, shipping, vehicles, military, medical treatment, combustion and recreation, or equipment in contact with food and beverages, emergency stop circuits, clutch and brake circuits in press applications, safety equipment or other applications unsuitable for the standard specifications described in the product catalog.
3. An application which could have negative effects on people, property, or animals requiring special safety analysis.
4. Use in an interlock circuit, which requires the provision of double interlock for possible failure by using a mechanical protective function, and periodical checks to confirm proper operation.

### Caution

#### 1. The product is provided for use in manufacturing industries.

The product herein described is basically provided for peaceful use in manufacturing industries.  
If considering using the product in other industries, consult SMC beforehand and exchange specifications or a contract if necessary.  
If anything is unclear, contact your nearest sales branch.

## Limited warranty and Disclaimer/ Compliance Requirements

The product used is subject to the following “Limited warranty and Disclaimer” and “Compliance Requirements”.  
Read and accept them before using the product.

### Limited warranty and Disclaimer

1. The warranty period of the product is 1 year in service or 1.5 years after the product is delivered, whichever is first.\*2)  
Also, the product may have specified durability, running distance or replacement parts. Please consult your nearest sales branch.
2. For any failure or damage reported within the warranty period which is clearly our responsibility, a replacement product or necessary parts will be provided. This limited warranty applies only to our product independently, and not to any other damage incurred due to the failure of the product.
3. Prior to using SMC products, please read and understand the warranty terms and disclaimers noted in the specified catalog for the particular products.

\*2) **Vacuum pads are excluded from this 1 year warranty.**  
A vacuum pad is a consumable part, so it is warranted for a year after it is delivered. Also, even within the warranty period, the wear of a product due to the use of the vacuum pad or failure due to the deterioration of rubber material are not covered by the limited warranty.

### Compliance Requirements

1. The use of SMC products with production equipment for the manufacture of weapons of mass destruction (WMD) or any other weapon is strictly prohibited.
2. The exports of SMC products or technology from one country to another are governed by the relevant security laws and regulations of the countries involved in the transaction. Prior to the shipment of a SMC product to another country, assure that all local rules governing that export are known and followed.

### Caution

#### SMC products are not intended for use as instruments for legal metrology.

Measurement instruments that SMC manufactures or sells have not been qualified by type approval tests relevant to the metrology (measurement) laws of each country. Therefore, SMC products cannot be used for business or certification ordained by the metrology (measurement) laws of each country.

 **Safety Instructions** Be sure to read the “Handling Precautions for SMC Products” (M-E03-3) and “Operation Manual” before use.

# Global Manufacturing, Distribution and Service Network

## Worldwide Subsidiaries

### EUROPE

**AUSTRIA**  
SMC Pneumatik GmbH (Austria)

**BELGIUM**  
SMC Pneumatics N.V./S.A.

**BULGARIA**  
SMC Industrial Automation Bulgaria EOOD

**CROATIA**  
SMC Industrijska Automatika d.o.o.

**CZECH**  
SMC Industrial Automation CZ s.r.o.

**DENMARK**  
SMC Pneumatik A/S

**ESTONIA**  
SMC Pneumatics Estonia

**FINLAND**  
SMC Pneumatics Finland OY

**FRANCE**  
SMC Pneumatique S.A.

**GERMANY**  
SMC Pneumatik GmbH

**GREECE**  
SMC Hellas EPE

**HUNGARY**  
SMC Hungary Ipari Automatizálási Kft.

**IRELAND**  
SMC Pneumatics (Ireland) Ltd.

**ITALY**  
SMC Italia S.p.A.

**LATVIA**  
SMC Pneumatics Latvia SIA

**LITHUANIA**  
SMC Pneumatics Lietuva, UAB

**NETHERLANDS**  
SMC Pneumatics BV

**NORWAY**  
SMC Pneumatics Norway A/S

**POLAND**  
SMC Industrial Automation Polska Sp.z.o.o.

**ROMANIA**  
SMC Romania S.r.l.

**RUSSIA**  
SMC Pneumatik LLC.

**SLOVAKIA**  
SMC Priemyselná Automatizácia, s.r.o.

**SLOVENIA**  
SMC Industrijska Avtomatika d.o.o.

**SPAIN / PORTUGAL**  
SMC España, S.A.

**SWEDEN**  
SMC Pneumatics Sweden AB

**SWITZERLAND**  
SMC Pneumatik AG

**UK**  
SMC Pneumatics (U.K.) Ltd.

### ASIA

**CHINA**  
SMC (China) Co., Ltd.

**HONG KONG**  
SMC Pneumatics (Hong kong) Ltd.

**INDIA**  
SMC Pneumatics (India) Pvt. Ltd.

**JAPAN**  
SMC Corporation

**MALAYSIA**  
SMC Pneumatics (S.E.A.) Sdn. Bhd.

**PHILIPPINES**  
SMC Pneumatics (Philippines), Inc.

**SINGAPORE**  
SMC Pneumatics (S.E.A.) Pte. Ltd.

**SOUTH KOREA**  
SMC Pneumatics Korea Co., Ltd.

**TAIWAN**  
SMC Pneumatics (Taiwan) Co., Ltd.

**THAILAND**  
SMC Thailand Ltd.

### NORTH AMERICA

**CANADA**  
SMC Pneumatics (Canada) Ltd.

**MEXICO**  
SMC Corporation (Mexico) S.A. DE C.V.

**USA**  
SMC Corporation of America

### SOUTH AMERICA

**ARGENTINA**  
SMC Argentina S.A.

**BOLIVIA**  
SMC Pneumatics Bolivia S.R.L.

**BRAZIL**  
SMC Pneumaticos do Brazil Ltda.

**CHILE**  
SMC Pneumatics (Chile) S.A.

**PERU**  
SMC Corporation Peru S.A.C.

**VENEZUELA**  
SMC Neumatica Venezuela S.A.

### OCEANIA

**AUSTRALIA**  
SMC Pneumatics (Australia) Pty. Ltd.

**NEW ZEALAND**  
SMC Pneumatics (N.Z.) Ltd.

## U.S. & Canadian Sales Offices

### WEST

Austin  
Dallas  
Los Angeles  
Phoenix  
Portland  
San Francisco

### EAST

Atlanta  
Birmingham  
Boston  
Charlotte  
Nashville  
New Jersey  
Rochester  
Tampa

### CENTRAL

Chicago  
Cincinnati  
Cleveland  
Detroit  
Indianapolis  
Milwaukee  
Minneapolis  
St. Louis

### CANADA

Montreal  
Toronto  
Vancouver  
Windsor

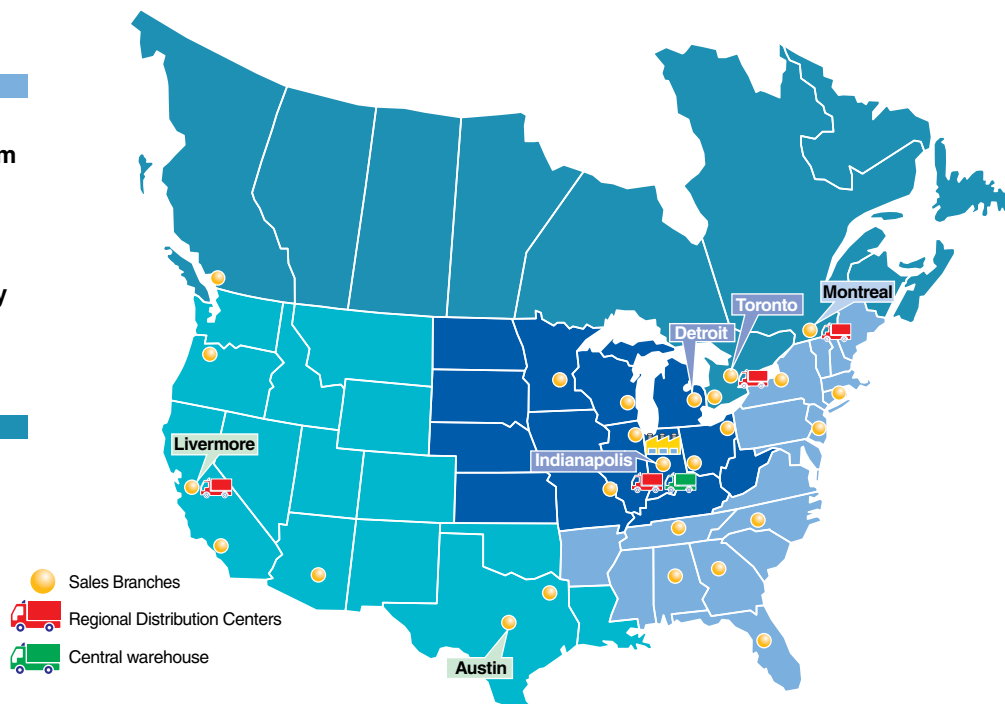

**SMC Corporation of America**  
10100 SMC Blvd., Noblesville, IN 46060  
[www.smcusa.com](http://www.smcusa.com)

**SMC Pneumatics (Canada) Ltd.**  
[www.smcpcneumatics.ca](http://www.smcpcneumatics.ca)

(800) SMC.SMC1 (762-7621)  
e-mail: [sales@smcusa.com](mailto:sales@smcusa.com)  
International inquiries: [www.smcworld.com](http://www.smcworld.com)

