

NEW PRODUCTS GUIDE

Digest version

Vol. 2



3 Port Solenoid Valve/Residual Pressure Release Valve with Detection of Main Valve Position VP/VG	P.01
Fieldbus System (Gateway Decentralized Type) EX500	P.03
3 Port 3 Position Valve VEX3	P.06
5 Port Solenoid Valve VQ4000/5000	P.07
5 Port Solenoid Valve VQC4000/5000	P.08
Compact Guide Cylinder MGP	P.09
Compact Guide Cylinder/With Flange MGP	P.10
Heat Resistant 2-Color Indicator Solid State Auto Switch/Direct Mounting Type D-M9□J	P.10
Compact Guide Cylinder JMGP	P.11
Compact Cylinder JCQ	P.12

Air Cylinder JMB	P.13
Air Cylinder MB	P.14
Air Cylinder MB1	P.14
Cylinder Speed Checker IN574-95/-73	P.15
Rotary Actuator/Vane Type CRB1	P.17
Vacuum Ejector/Body Ported Type ZH	P.18
Vacuum Unit ZK2	P.19
Vacuum Filter AFJ	P.21
Moisture Control Tube IDK	P.23
Water Regulator WR110-□-X224/WR110-□-X215	P.24

Water Strainer WF300	P.24
3-Screen Display High-Precision Digital Pressure Switch ZSE20(F)/ISE20	P.25
Speed Controller with Indicator AS-FS	P.30
Card Motor LAT3	P.31
4 Axis Step Motor Controller (Parallel I/O) JXC73/83	P.32
Step Motor Controller JXC91	P.33
Rotary Joint MQR-X229	P.34
Large Size Booster Relay XT240	P.34



3 Port Solenoid Valve/

Residual Pressure Release Valve with Detection of Main Valve Position

VP/VG Series

*1. Refer to page 2 for compliant products.
*2. Refer to page 2 for certified products.

For details, refer to the **WEB catalog** or the catalog of each product.

CAT.NAS11-111

With Detection of Main Valve Position

Category 2

The detecting function of the main valve position detects a mismatch between the input signal and valve operation.

Residual pressure release valve



Safety limit switch

VP542-X536

Redundant system can be constructed easily.

Category 3, 4

When the dual residual pressure release valve is used, if one of the valves fails to operate, the other one releases residual pressure.

Dual Residual Pressure Release Valve
VP544-X538

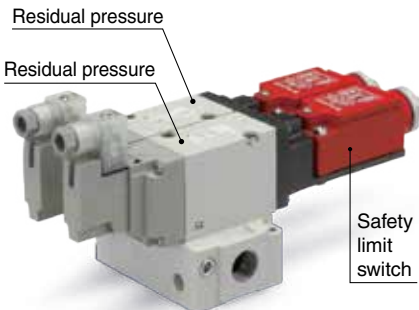

With Soft Start-up Function
VP544-X555

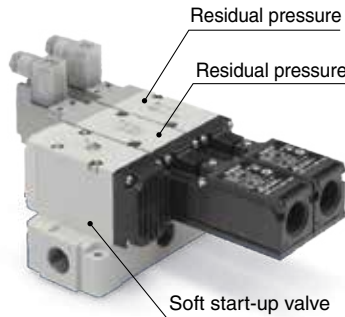

Dual Residual Pressure Release Valve
VG342-X87



Redundant System

A system in which even if one part fails, the whole system will fulfill its required function. This is usually achieved by having dual channels of operation, such as dual valves, dual wiring, dual guard switches etc.

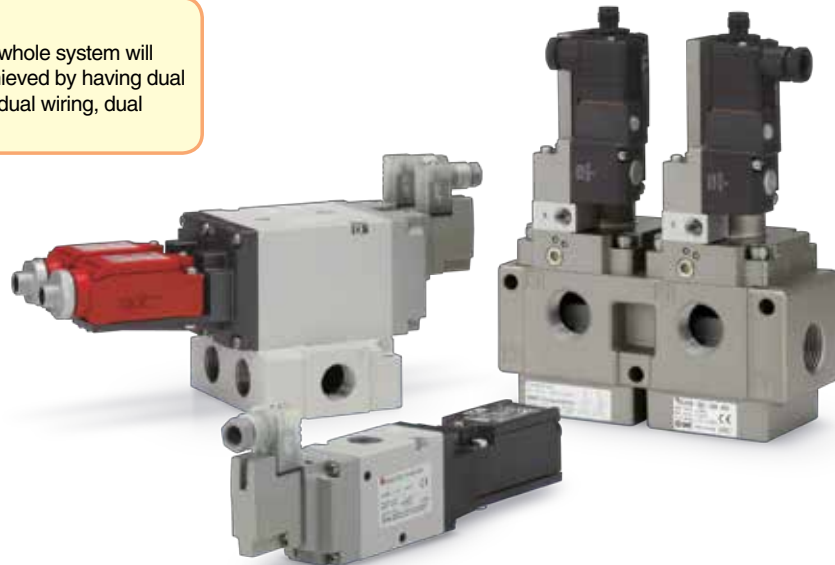

Highly reliable construction

- ① The main valve position is detected by transferring the main valve movement directly to the reed safety limit switch with the rod.

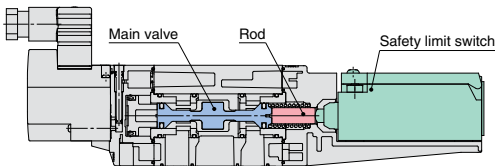

- ① Long service life: B10d: 10 million times*
- ② The return spring releases the residual pressure securely regardless of pressure level.

* For VP500/700, safety limit switch made by OMRON

Safety limit switch can be selected.



Made by OMRON



Made by Rockwell Automation

Conduit (VP series only) and M12 M12 connector with 6 pins is available. M12 connector (4 pin) types are available.

With soft start-up function (-X555)

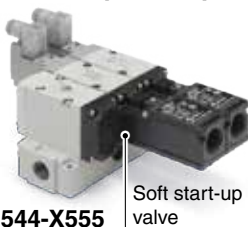

VP544-X555 Soft start-up valve

- A function to gradually increase the initial pressure of the pneumatic system has been added to the dual residual pressure release valve.
- Fixed orifice and variable throttle are available as a throttle for adjusting the pressure increase. ($\phi 1$, $\phi 1.5$, $\phi 2$)

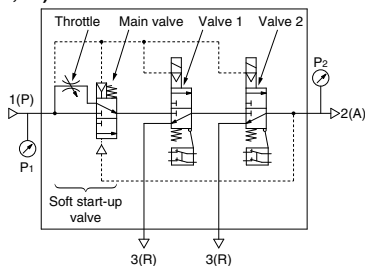

Output Pressure (P2) vs Time Graph

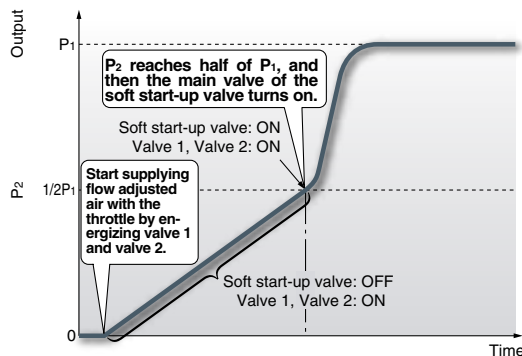

Standards and Enclosure

Series	Category	Safety limit switch manufacturer	Standards						Enclosure
			Machinery Directive	2006/42/EC		CE	cUL	RoHS	
			Harmonized standards	EN ISO13849-1: 2008 EN ISO13849-2: 2012	EN ISO4414: 2010				
Residual Pressure Release Valve VP542/742-X536	2	OMRON Corporation							IP65
		Rockwell Automation, Inc.							
Dual Residual Pressure Release Valve VP544/744-X538	3, 4	OMRON Corporation							IP65
		Rockwell Automation, Inc.							
Dual Residual Pressure Release Valve with Soft Start-up Function VP544/744-X555	3, 4	OMRON Corporation							IP65
		Rockwell Automation, Inc.							
Dual Residual Pressure Release Valve VG342-X87	3, 4	OMRON Corporation						*	IP40
		Rockwell Automation, Inc.							

* Only port size 3/4"

Series Variations

Series	Category	Port size	Thread	Flow rate characteristics C [dm ³ /(s·bar)] 1→2 (P→A)				
				5	10	15	20	25
Residual Pressure Release Valve VP542-X536	2	3/8"	Rc G	8.9				
Residual Pressure Release Valve VP742-X536		1/2"	NPT	15.1				
Dual Residual Pressure Release Valve VP544-X538	3, 4	3/8"	Rc G	6.5				
Dual Residual Pressure Release Valve VP744-X538		1/2"	NPT	10.3				
Dual Residual Pressure Release Valve with Soft Start-up Function VP544-X555	3, 4	3/8"	Rc G	5.2				
Dual Residual Pressure Release Valve with Soft Start-up Function VP744-X555		1/2"	NPT	9.8				
Dual Residual Pressure Release Valve VG342-X87	3, 4	3/4"	Rc G NPT	26.6				

Can be connected to Modular type F.R.L. units.

- Applicable models*
- VP544/744-X538
 - VP544/744-X555

* Please contact SMC for the VP542/742-X536.

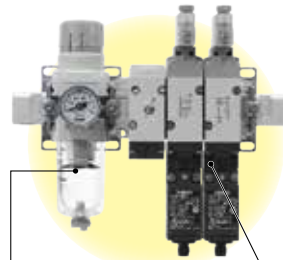

Filter regulator (Optional accessory)

Dual residual pressure release valve with soft start-up function

Fieldbus System

(Gateway Decentralized Type)

EX500 Series

Gateway Decentralized System 2 added!



For details, refer to the **WEB catalog** or the catalog of each product.

CAT.NAS02-26

Description	Compatible protocol	Number of inputs/outputs	Number of valve manifold and Input Unit connections	Branch cable length	New function
New Gateway Decentralized System 2	EtherNet/IP	128 inputs/128 outputs	Max. 16 Units	Max. 20 m	Web server function • Valve operation test • Connection diagnostic • Short-circuit diagnostic
Gateway Decentralized System	DeviceNet	64 inputs/64 outputs	Max. 8 Units	Max. 10 m	—

Decentralized valve installation

Valves can be installed near the actuators!

- Reduced piping space and piping materials
- Reduced wiring space
- No need to set the address for the valve manifold and Input Unit.

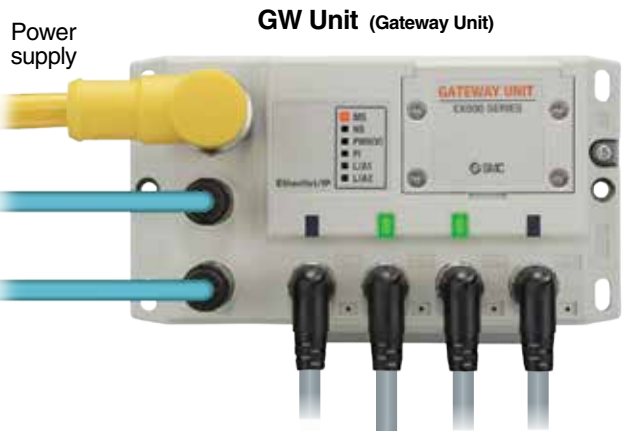

● Number of branch ports: **4**

Number of inputs/outputs → **128** inputs/**128** outputs

● Number of inputs/outputs per branch: Max. **32** inputs/**32** outputs

Number of valve manifold connections → Max. **8** Units*

● Number of valve manifold connections per branch: Max. **2** Units*

Number of Input Unit connections → Max. **8** Units

● Number of Input Unit connections per branch: Max. **2** Units

Total cable length per branch → Max. **20** m

* When the number of outputs is set to "16 outputs" using a built-in setting switch of the SI Unit.

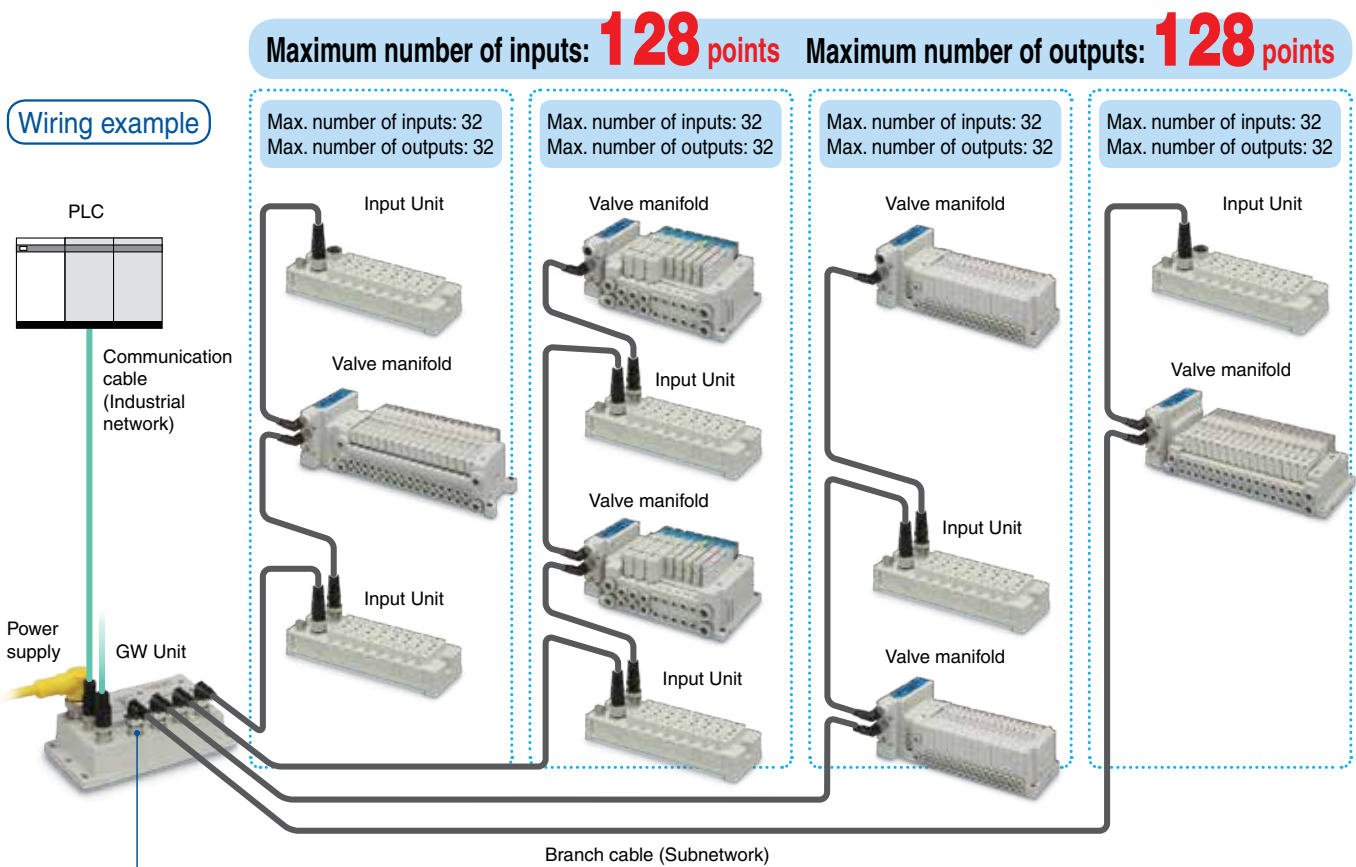

Branch port

Two valve manifolds can be connected to one branch port.

SI Unit has a built-in setting switch which switches the number of outputs (32 points / 16 points) of the valve manifold connected to the SI Unit. By setting the number of outputs to 16 points, two valve manifolds can be installed to one branch port.

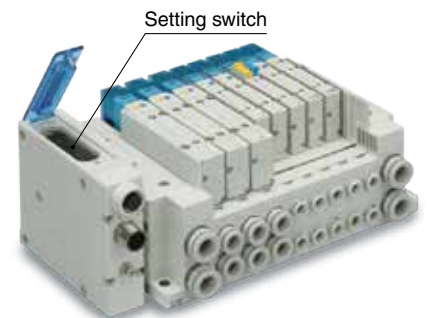

SI Unit

Web server function

Valve operation test (ON/OFF), connection diagnostic between valve manifold and Input Unit, and short-circuit diagnostic of input device can be performed on a Web browser.

A password can be used for the valve operation test (ON/OFF) for security.

The location of the error can be identified. Details of the error can be identified on a Web browser.

No need to set the address

I/O mapping for the SI Unit and Input Unit is set by the Gateway Unit automatically.

The Unit installation order is not specified.

(The upper limit of the inputs / outputs is 32 points for one branch port.)

Accessories can be ordered together.

Accessories including cables and connectors can be ordered together to SMC.

Time for selecting parts, ordering and managing lead time can be reduced.

Applicable to output devices other than valve manifold.

By using output block, lights and buzzers can be operated.

Specified valve manifold can be controlled by supplying power from a different system.

By using a Y branch connector, power from a different system can be supplied to the SI Unit (valve manifold).

<Example of use>

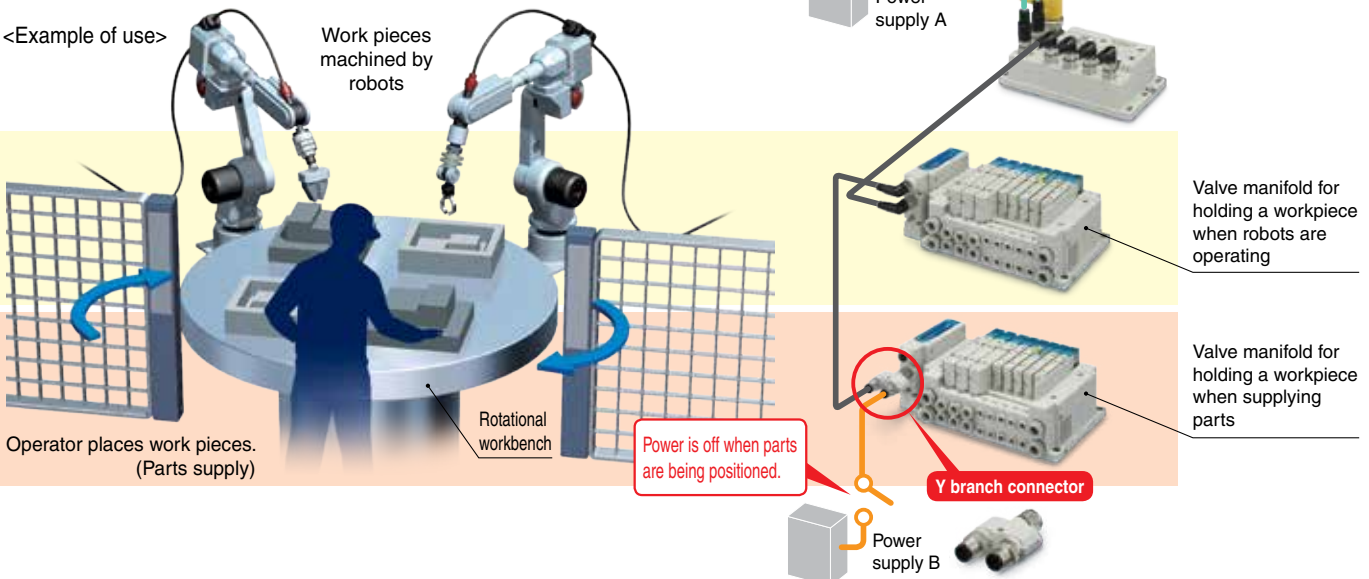

Pilot Solenoid

Air Operated



CAT.NAS11-112

3 Port 3 Position Valve

VEX3 Series

For details, refer to the **WEB catalog** or the catalog of each product.

Intermediate stopping of cylinders up to $\varnothing 125^*$ is possible.



* For VEX3 $\frac{3}{4}$ 2□, 300 mm/s, horizontal movement

Power consumption: 1 W

3 Manual override options added

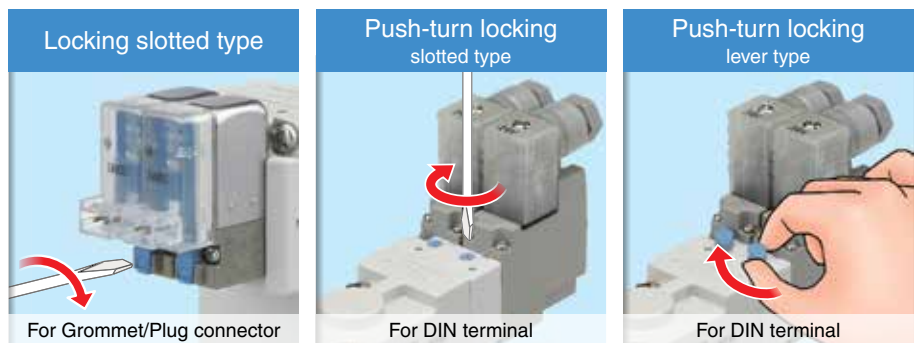

Variations

	Body size	Port size	Flow rate characteristics ¹ C [dm ³ /(s·bar)]	Applicable cylinder ²			
				ø63	ø80	ø100	ø125
Body ported	VEX312□	1/4	3.5		●		
	VEX332□	3/8	8.7			●	
Base mounted	VEX322□	1/4	4.4		●		
	VEX342□	1/2	14				●

*1 For 2 (A) → 3 (R) *2 For 300 mm/s, horizontal movement



Metal Seal

Rubber Seal

5 Port Solenoid Valve

VQ4000/5000 Series

For details, refer to the **WEB catalog** or the catalog of each product.



CAT.NAS11-104

Installation volume

42% Reduction

Installation area

26% Reduction

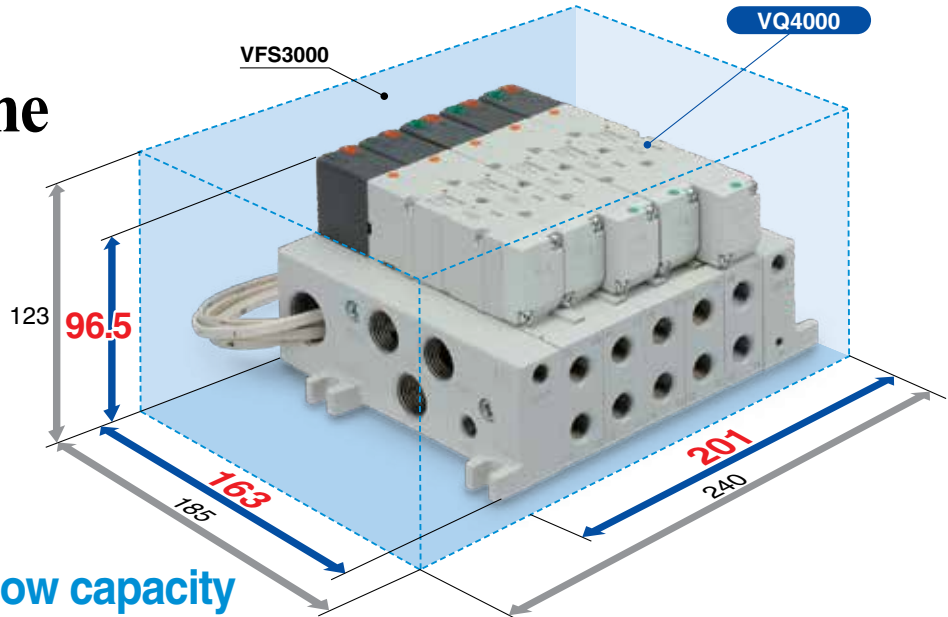

- Compact and large flow capacity

VQ4000 Possible to drive cylinders up to $\varnothing 160^*$

VQ5000 Possible to drive cylinders up to $\varnothing 180^*$

* When the average speed is 200 mm/s.

VQ4000: 25 mm pitch

C [dm³/(s·bar)]: 7.3*

VQ5000: 41 mm pitch

C [dm³/(s·bar)]: 17*

* 2-position single, rubber seal, 4/2 → 5/3 (A/B → R1/R2)

Power saving

	Power consumption [W]	Maximum operating pressure [MPa]
New VQ	0.4 (0.95)	1.0
Current product	0.5 (1.0)	0.7

* Low wattage type () : Standard

- Long service life

100 million cycles

* According to SMC life test conditions

- Enclosure IP65 compliant
Dust-tight/Water-jet-proof

* When manifold is IP65 compliant.

* Except F and T1 kits



Metal Seal

Rubber Seal

5 Port Solenoid Valve

VQC4000/5000 Series

For details, refer to the **WEB catalog** or the catalog of each product.



CAT.NAS11-108

Compact and large flow capacity

VQC4000 Possible to drive cylinders up to $\varnothing 160$

VQC5000 Possible to drive cylinders up to $\varnothing 180$ * When the average speed is 200 mm/s.



VQC4000: 25 mm pitch

C [dm³/(s·bar)]: 7.3*

VQC5000: 41 mm pitch

C [dm³/(s·bar)]: 17*

* 2-position single, rubber seal: 4/2 → 5/3 (A/B → R1/R2)

Connector type manifold

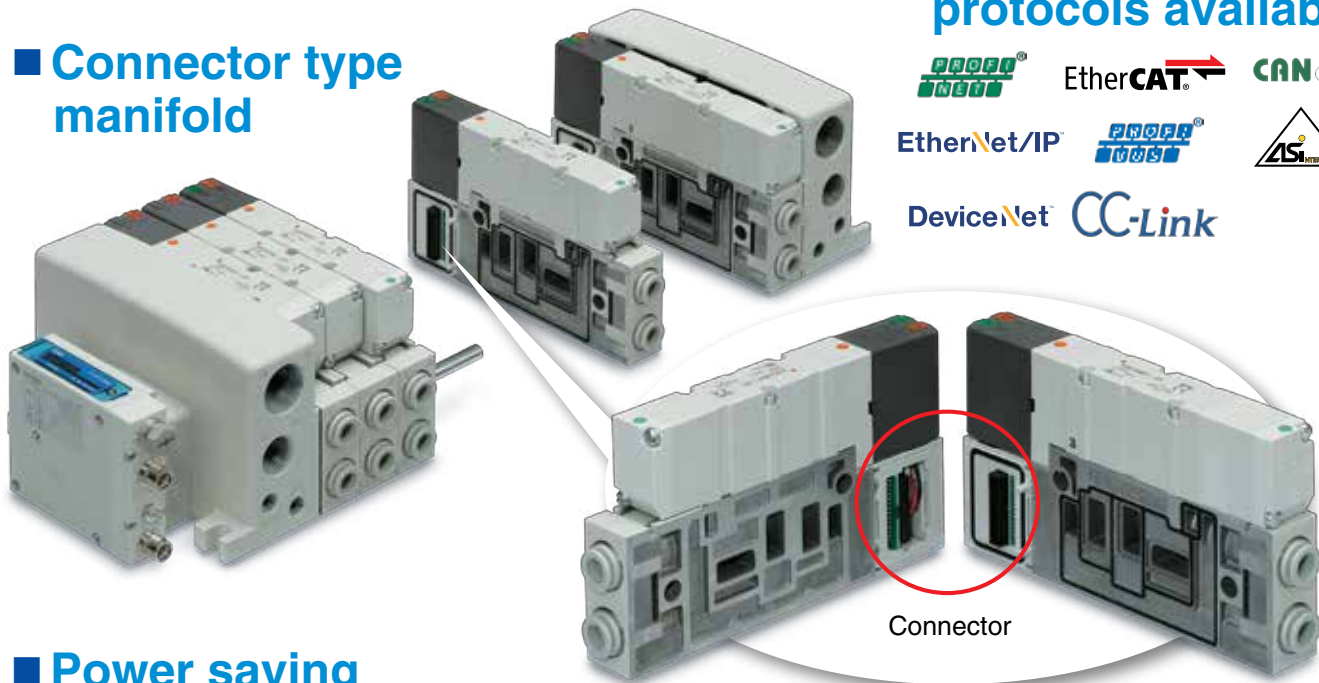

Extensive range of protocols available



EtherNet/IP



DeviceNet

CC-Link

Connector

Power saving

	Power consumption [W]	Maximum operating pressure [MPa]
New VQC	0.4 (0.95)	1.0
Current product	0.5 (1.0)	0.7

* Low wattage type (): Standard

Long service life

100 million cycles

* According to SMC life test conditions

Enclosure IP67 compliant

* Except F and P kits



Compact Guide Cylinder

ø12, ø16, ø20, ø25, ø32, ø40, ø50, ø63, ø80, ø100

MGP Series

- Cylinder with stable lubrication function (Lube-retainer) and Guide unit with Lube-retainer added.
- Shock absorber soft type RJ series type (-XB22) and Spatter resistant specification (-XC88, 89, 91) added.

For details, refer to the **WEB catalog** or the catalog of each product.



CAT.NAS20-219

Weight reduced by up to **24%** with a shorter guide rod and thinner plate



3 types of bearing can be selected.

● Slide bearing

MGPM series

● Ball bushing

MGPL series

● High precision ball bushing

MGPA series



for MGPM40-25 stroke

Guide rod shortened

Max. **22 mm**

Space required between the bottom of the cylinder body and your equipment is reduced.

Space saving



With air cushion

Water resistant cylinder

Compact Guide Cylinder

With Flange

∅12, ∅16, ∅20, ∅25, ∅32, ∅40, ∅50, ∅63, ∅80, ∅100

MGP Series

Plate side flange type added.



For details, refer to the **WEB catalog** or the catalog of each product.

15-E649

Application Example

Delivery

Compact guide cylinder with flange

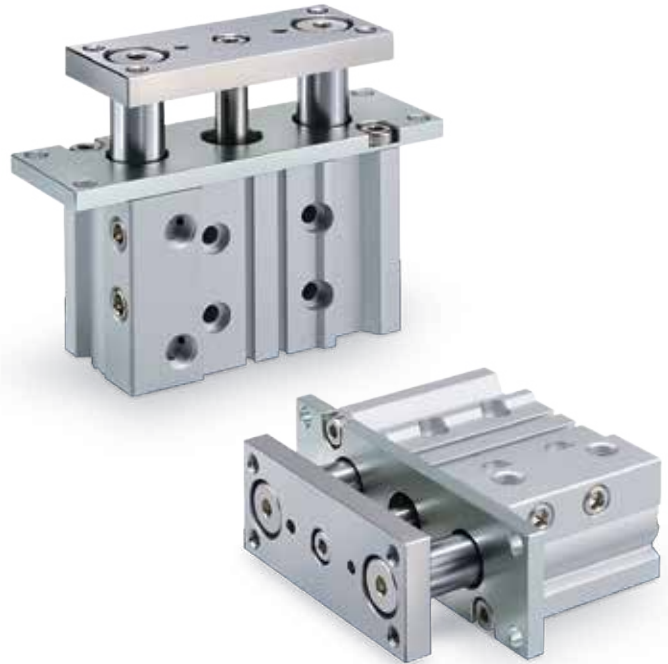
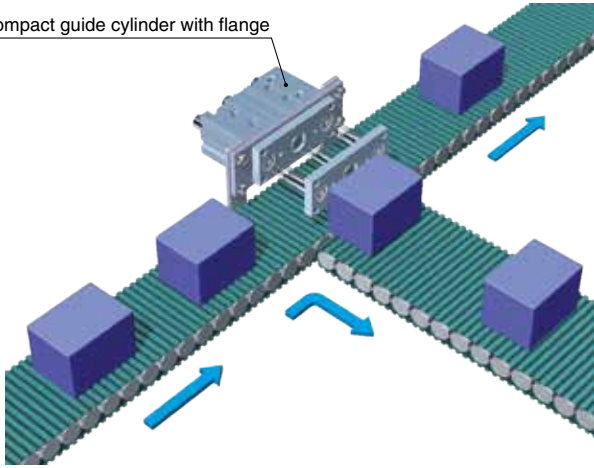

Heat Resistant 2-Color Indicator Solid State Auto Switch Direct Mounting Type



For details, refer to the **WEB catalog** or the catalog of each product.

15-E644

D-M9□J Series

Heat resistant (Max. 302°F [150°C]) type added to the D-M9□ compact auto switch. Choice of output types: PNP, NPN

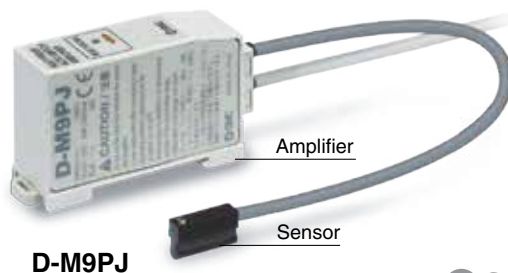

D-M9PJ

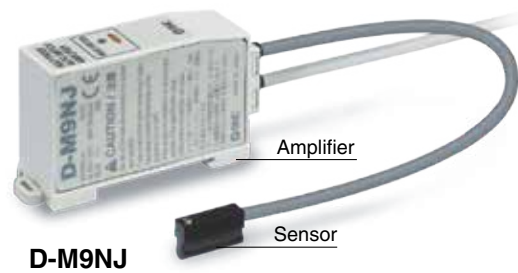

D-M9NJ



Compact Guide Cylinder

ø12, ø16, ø20, ø25, ø32, ø40, ø50, ø63

JMGP Series

Bore sizes ø40, ø50, ø63 added.



CAT.NAS20-238

For details, refer to the WEB catalog or the catalog of each product.

Compact

Overall length shortened

Height shortened

JMGP ø32

JMGP ø32

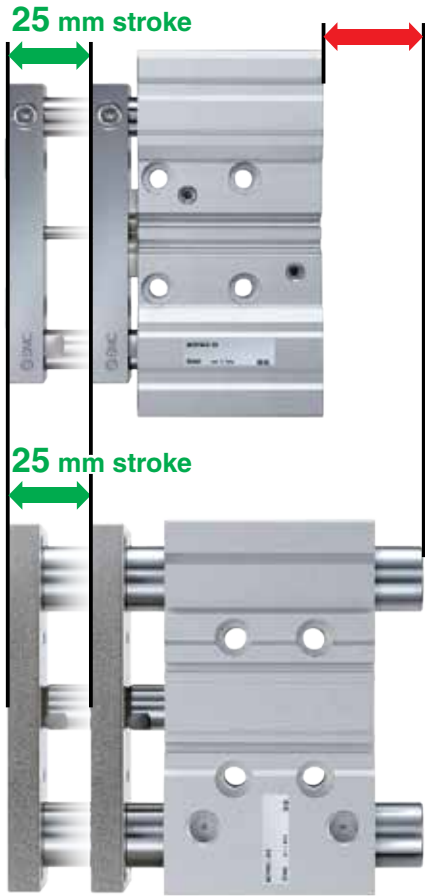

30.5 mm

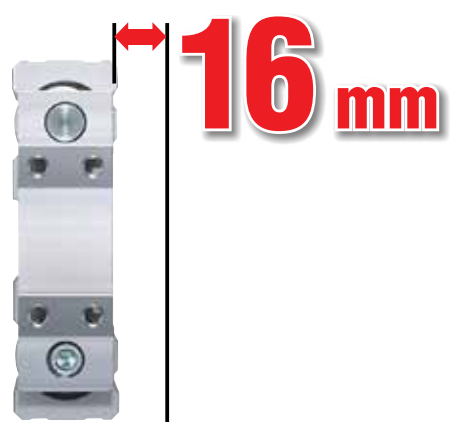

16 mm

Current product ø32

Current product ø32

Weight

Max. **69% lighter**

0.32 kg → 0.1 kg

(Compared with the current MGP-Z series, ø16, 10 mm stroke)

● Suitable for pushing, lifting or clamping in a transport line.



Compact Cylinder

ø12, ø16, ø20, ø25, ø32, ø40, ø50, ø63

JCQ Series

Bore sizes ø40, ø50, ø63 added.

RoHS



For details, refer to the WEB catalog or the catalog of each product.

CAT.NAS20-239

Compact

Overall length shortened

Width shortened



6.5 mm



6 mm

Height shortened

4 mm



Current product ø20
(CDQS series)

Current product ø20
(CDQS series)

JCQ ø20

Max.
Weight **45% lighter**

150 g → 82 g

(Compared with the current CDQS series, ø25, 10 mm stroke)



Air Cylinder

RoHS



CAT.NAS20-240

ø32, ø40, ~~ø45~~, ø50, ~~ø56~~, ø63, ~~ø67~~, ø80, ~~ø85~~, ø100

JMB Series

For details, refer to the **WEB catalog** or the catalog of each product.

Bore sizes ø63 to ø100 added. ø63 to ø100 added.

Intermediary Bore Sizes

- Air saving
- Space saving

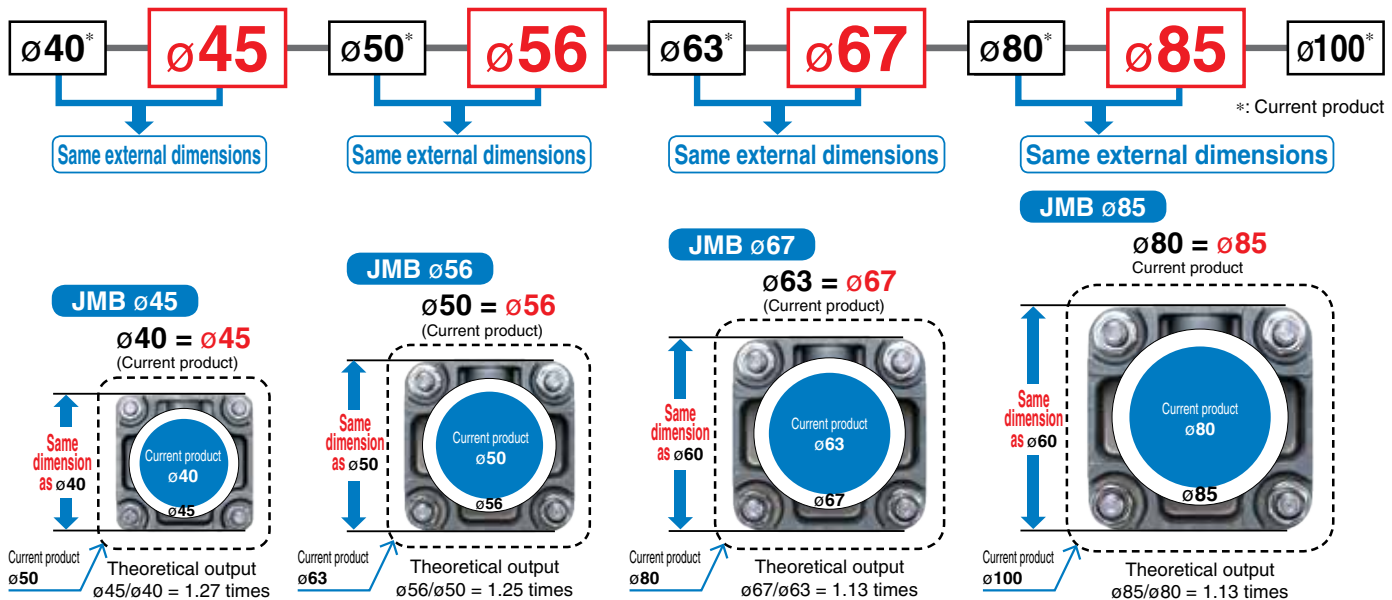

Overall length shortened



Max.

Weight

30% lighter

1.43 kg → 1.00 kg

(Compared with the current MB series, ø50, 100 mm stroke)

Air Cylinder

ø32, ø40, ø50, ø63, ø80, ø100, ø125

MB Series

Non-rotating rod type added. (Single rod, Double rod)



For details, refer to the WEB catalog or the catalog of each product.

CAT.NAS20-231

Weight **16% lighter** (ø63-100 stroke)

New MB Series

Current model

1.69 kg <<< 2.01 kg



Reduced weight by changing the shape of the rod cover and head cover.

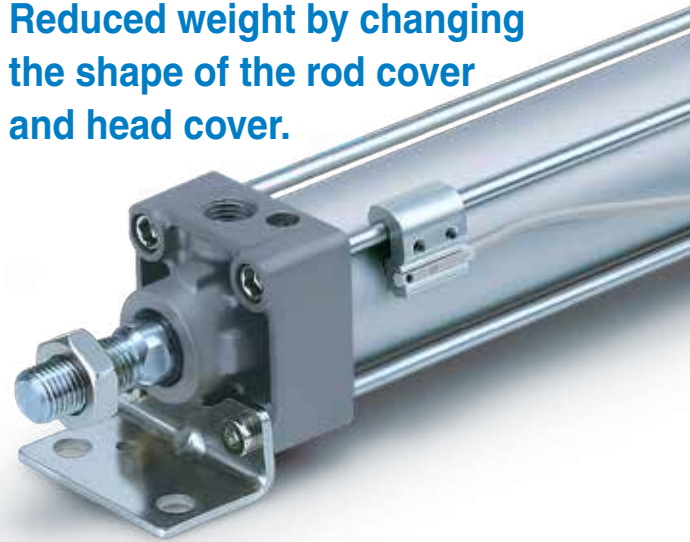

Air Cylinder

ø32, ø40, ø50, ø63, ø80, ø100, ø125

MB1 Series

Non-rotating rod type added.



For details, refer to the WEB catalog or the catalog of each product.

CAT.NAS20-234

Weight **10% lighter** (ø63-50 stroke)

New MB1 Series

Current model

1.7 kg <<< 1.9 kg

Reduced weight by changing the shape of the rod cover and head cover.

Can mount small auto switches on 4 surfaces.

Dust-protected Fastener on auto switch mounting groove for dust-prevention (Option)



Cylinder Speed Checker (Built-in Magnet Cylinder) IN574-95/-73



For details, refer to the **WEB catalog**
or the catalog of each product.

14-E641

3
measurement
modes

Speed (mm/s)

Time required for stroke (s)

Operation count (Times)



**Realizes increase in efficiency with
visualization of air cylinder operation.**

- Quantification of cycle time improvements
- For reduction of numerical management/adjustment labor when starting up equipment
- For reduction of numerical confirmation/inspection labor during periodic maintenance

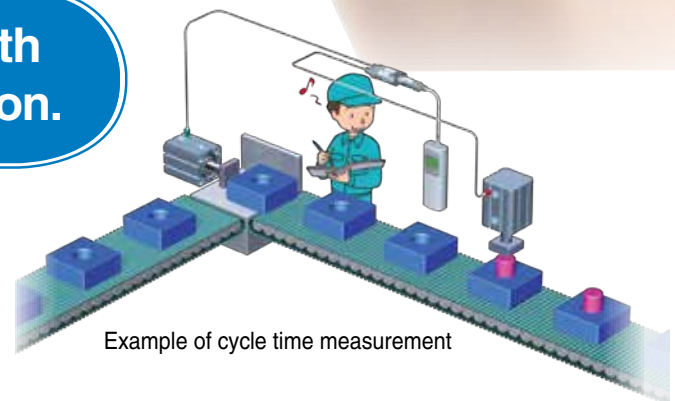

Example of cycle time measurement

⚠ Caution The measurement may not be performed with an air gripper or rotary actuator, or the measurement deviation may increase. Please contact SMC for more information.

3 Measurement Modes

Speed (mm/s)

Measures the speed of cylinders.

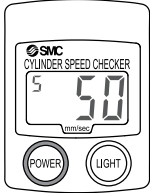

Rated measurement range (Note)
-1999 to 1999 mm/s

Note) Minus (-) is added to the measured value to distinguish the extension and retraction of a cylinder.

Rod extension end: Positive direction

Rod retraction end: Reverse direction (-)

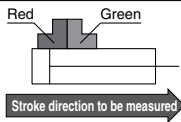

* Although a measurement can be done even when the sensor is mounted in the reverse direction, the display direction is also reversed.

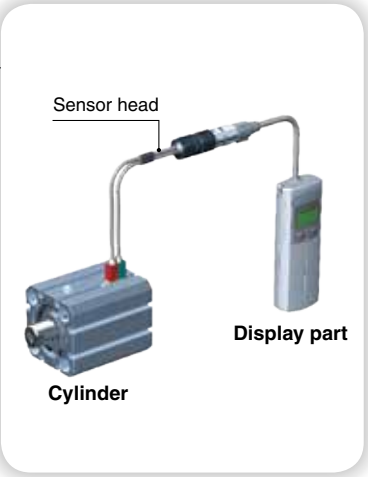
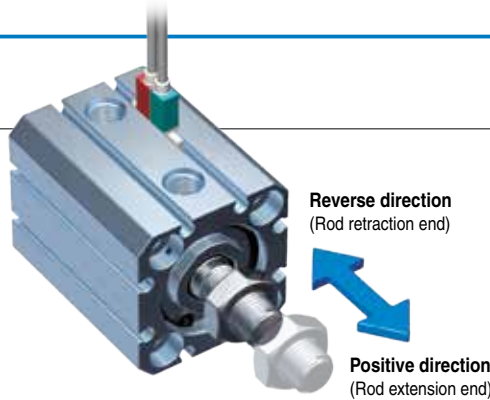

Time required for stroke (s)

Measures the time required for the stroke of the cylinder (rod retraction end to rod extension end).

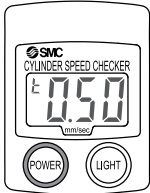

Rated measurement range (Note)
-999.9 to 999.9 s

Note) Minus (-) is added to the measured value to distinguish the extension and retraction of a cylinder.

Rod extension end: Positive direction

Rod retraction end: Reverse direction (-)

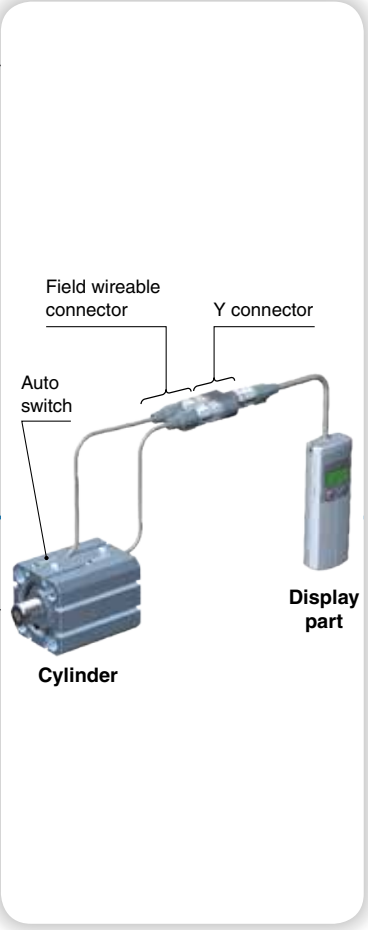
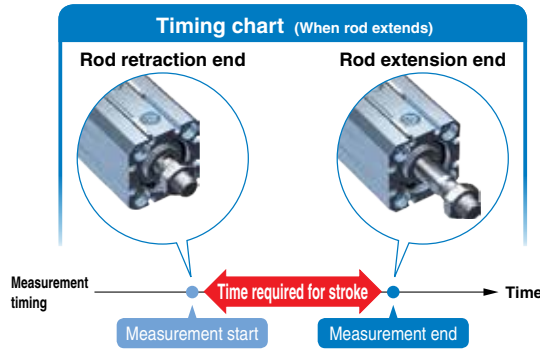

Operation count (Times)

Measures the operation count of a cylinder for 1 minute.

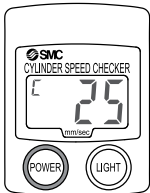

Rated measurement range (Note)
0 to 999 time

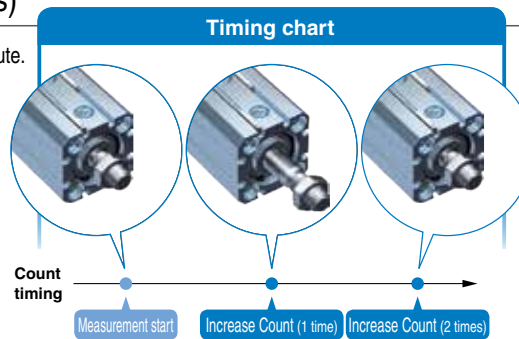

- Compact: 40 (Width) x 110 (Height) x 20 (Depth) mm
- Lightweight: Approx. 65 g (Body)/25 g (Sensor)
* Excluding dry cell batteries.
- Battery powered: 2A dry cell battery x 2, continuous use for 15 hours or more.

- With backlight
- With auto power-off function*
* If a button is not operated for 15 min. or more, the power supply will turn off automatically.



Vane Type Rotary Actuator

50, 63, 80, 100

CRB1 Series

Compact auto switches are mountable! (D-M9□)

For details, refer to the WEB catalog or the catalog of each product.



CAT.NAS20-247



Compact auto switch D-M9□

Stainless steel specification for main parts

Made to Order

Size: 50, 63, 80, 100

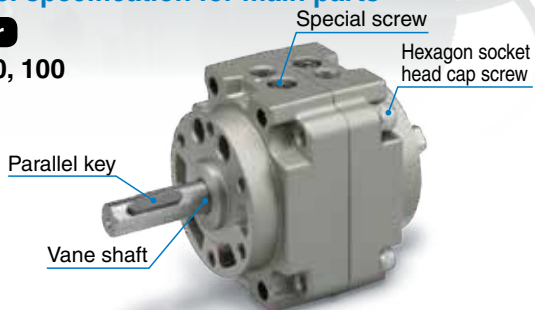

Two different port locations (side and axial) are available.



Mounting

Direct mounting

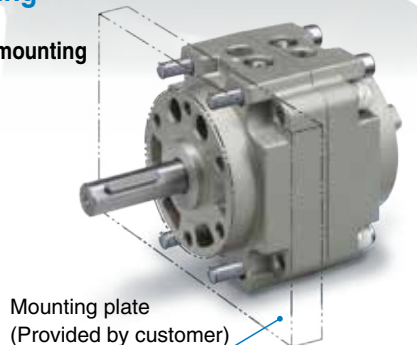

Foot mounting



Vacuum Ejector

Body Ported Type

ZH Series



For details, refer to the **WEB catalog** or the catalog of each product.

CAT.NAS100-109

Compact and Lightweight

Overall length Max. **11%** reduction (6.7 mm shorter)

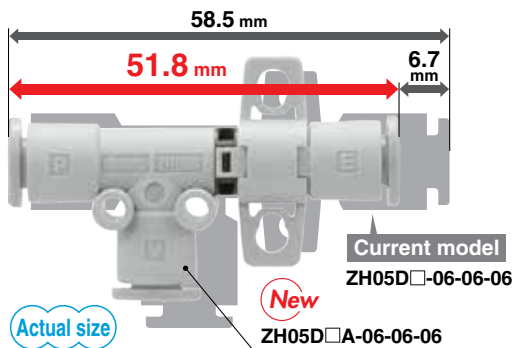

Port height Max. **25%** reduction (9.1 mm shorter)



Weight Max. **74%** reduction (65.1 g lighter)

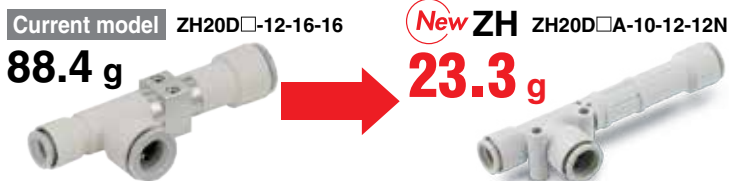

4 mounting types

Direct mounting

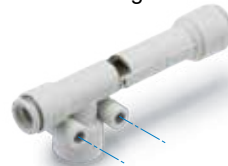

Standard bracket mounting



L-bracket mounting



DIN rail mounting



Variations

Model	Nozzle nominal size [mm]	Vacuum pressure reached* psi [kPa]		Maximum suction flow rate scfm [L/min (ANR)]		Air consumption scfm [L/min (ANR)]	
		Type S	Type L	Type S	Type L		
ZH05D□A	0.5	-13 [-90]	-7 [-48]	0.21 [6]	0.46 [13]	0.46 [13]	
ZH07D□A	0.7			0.42 [12]	0.99 [28]	0.95 [27]	
ZH10D□A	1.0			0.92 [26]	1.84 [52]	1.84 [52]	
ZH13D□A	1.3		-10 [-66]	-10 [-66]	1.41 [40]	2.75 [78]	2.97 [84]
ZH15D□A	1.5				2.05 [58]	2.75 [78]	3.99 [113]
ZH18D□A	1.8				2.68 [76]	4.52 [128]	5.72 [162]
ZH20D□A	2.0	3.18 [90]			5.47 [155]	6.92 [196]	

* Supply pressure: 65 psi [0.45 MPa]





CAT.NAS100-102

Vacuum Unit

ZK2 Series

High-noise reduction silencer added

For details, refer to the WEB catalog or the catalog of each product.

Energy saving ejector

Digital pressure switch for vacuum with energy saving function cuts supply air when the pressure reached the desired vacuum.

Air consumption

90% reduction*

* Based on SMC's measuring conditions

More efficient ejector

Suction flow

50% increase

Air consumption

30% reduction

(Compared to other SMC single stage ejectors)

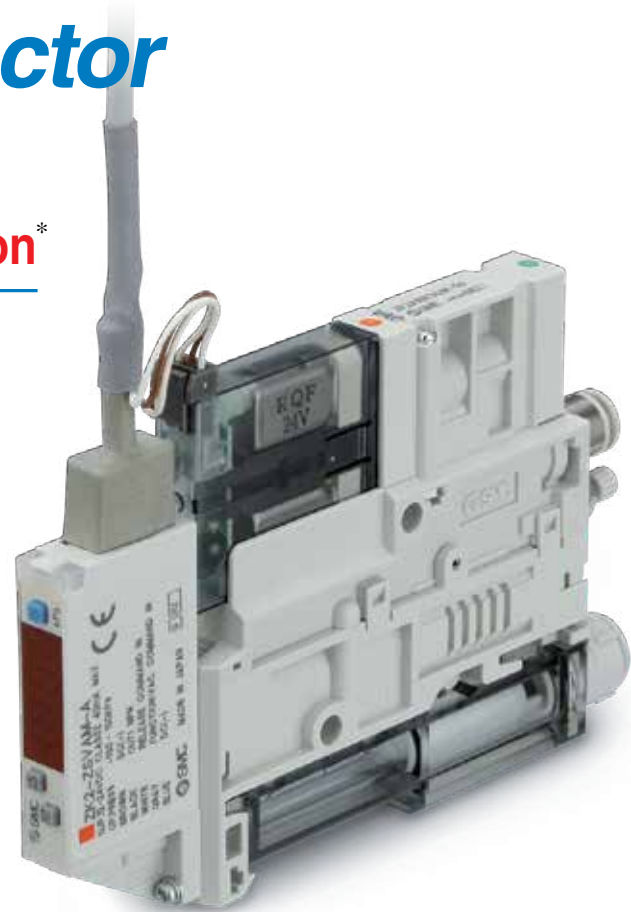
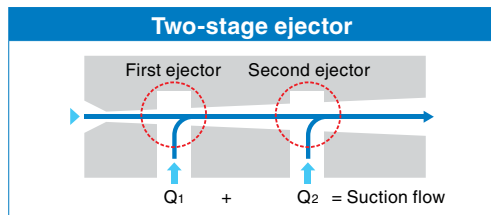

Compact/Lightweight

Volume 88 cm³

28% reduction

Weight 81 g

59% reduction

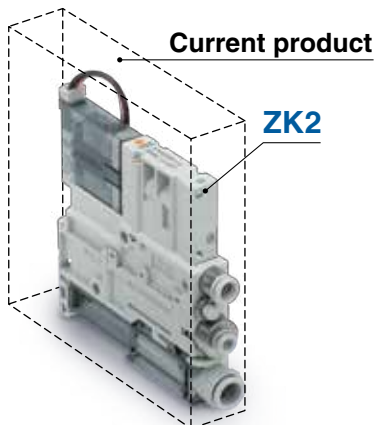

Reduced-wiring

D-sub connector/Flat ribbon cable/Individual wiring

New

High-noise reduction silencer added

Low noise: 46 dB*¹(A)

Suction flow rate:

Improved by up to approx. 20%*²

*¹ Nozzle size: $\phi 0.7$

*² Nozzle size: $\phi 1.5$

(Based on SMC's measuring conditions)

High-noise reduction silencer

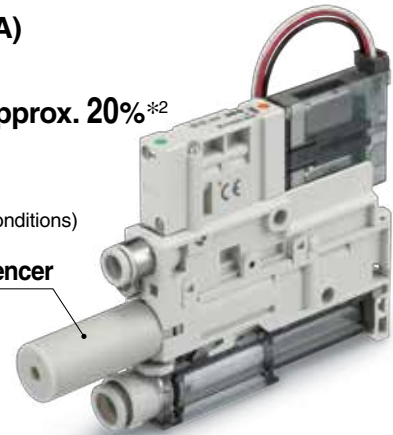

Energy saving ejector

Digital pressure switch **with energy saving function**

reduces air consumption by **90%*** * Based on SMC's measuring conditions

Digital pressure switch for vacuum with energy saving function

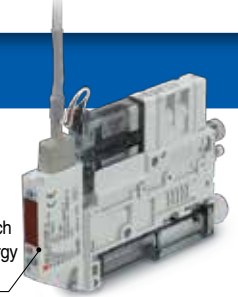

While the suction signal is ON, the ON/OFF operation of the supply valve is also performed automatically within the set value.

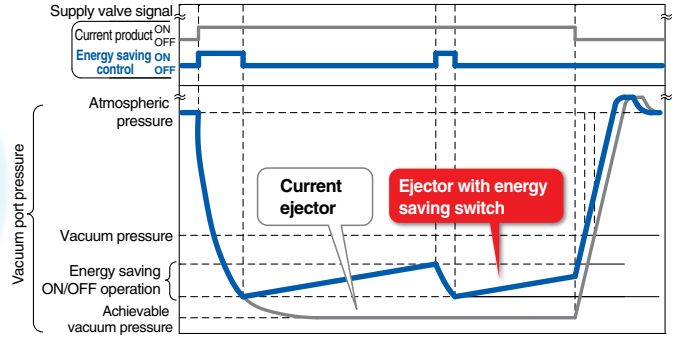
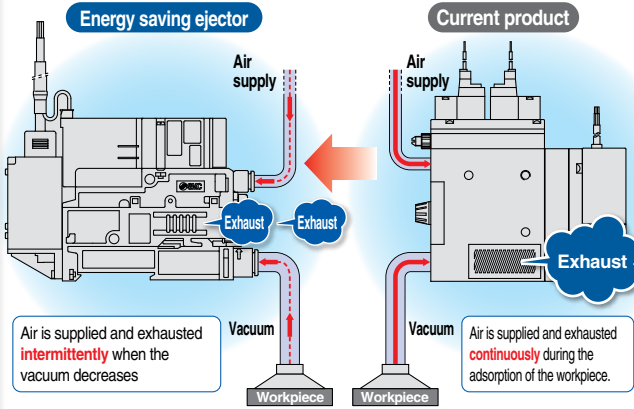

Energy saving efficiency

Power consumption cost per year reduced by \$716/year

The energy saving function shortens the exhaust time, which reduces the annual power consumption cost.

	Power consumption cost per year	Energizing time per year	Exhaust time	Compressor's consumption per unit time
ZK2/With energy saving function	\$54/year	1,875 h/year	0.6 s	0.19 kWh
Current product	\$770/year	18,750 h/year	6 s	0.27 kWh

Cost conditions

- Electric power charge: 15 JPY/kWh, Operating hours: 10 hours/day, Operating days: 250 days/year, When 10 units are used
- Power consumption of the compressor is the theoretical value from the air consumption of each product at 0.35 MPa.

Improved low noise and suction flow by adoption of a through-hole silencer

Low noise

46 dB* (A)

*Nozzle size: $\phi 0.7$

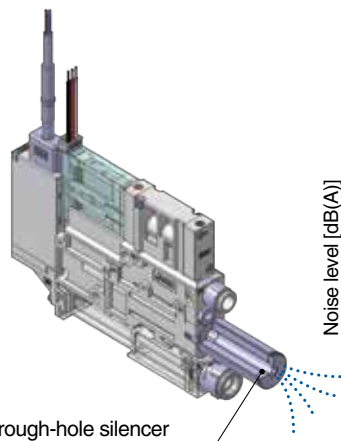

Through-hole silencer

The exhaust is discharged directly to atmosphere, cutting off the unpleasant frequency while exhibiting the maximum possible vacuum performance.

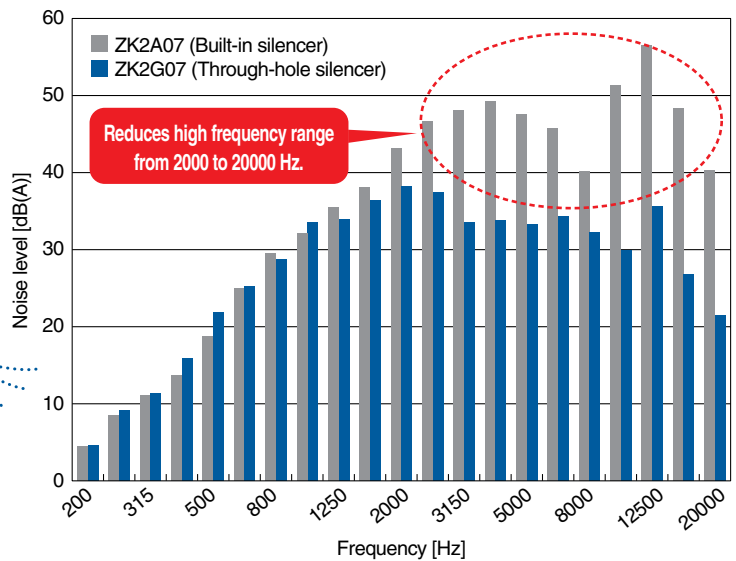

Suction flow rate

Improved by up to approx. **20%**

Nozzle size	Exhaust type	Maximum suction flow rate scfm [L/min (ANR)]	
		1.4 [40]	2.8 [80]
$\phi 1.5$	Through-hole silencer	2.8 [80]	
	Built-in silencer	2.4 [67]	

Approx. **20%**

Vacuum Filter

AFJ Series



For details, refer to the **WEB catalog** or the catalog of each product.

CAT.NAS100-116

Prevents vacuum equipment trouble!

Nominal filtration rating **5, 40, 80** μm

Large flow capacity **max. 23.3 scfm**
660 L/min (ANR)

* Large flow type ($\Delta P = 0.6$ psi [4 kPa])

● **Elements can be reused by washing them.**

* For 40 μm and 80 μm

● **Water drops can be removed.***

* Water drop removal ratio: 80%. At recommended flow rate (representative values).

* For water drop removal type



Better environmental resistance with 2 layer construction

Transparent bowl guard Inner bowl

Material: Polycarbonate

The bowl is covered with a transparent bowl guard!

* Body size 30 or more

There are no windows on the bowl guard and the inner bowl is instead covered with a **polycarbonate transparent bowl guard**. Now, even if the environment changes and the bowl is exposed to corrosive chemical or oil splash, **the foreign matter will not stick directly to the pressurized bowl. This can reduce risk of bowl breakage.**

Model	Flow rate scfm [L/min(ANR)]						Port size				Nominal filtration rating μm	
	3.5 [100]	7.1 [200]	10.6 [300]	14.1 [400]	17.7 [500]	21.2 [600]	1/8	1/4	3/8	1/2		
AFJ20	MAX. 6.36 [180]						●	●				5, 40, 80
AFJ30	MAX. 13.4 [380]							●	●			
AFJ40	MAX. 23.3 [660]							●	●	●		

Large flow type ($\Delta P = 0.6$ psi [4 kPa])

2 types are available for different applications.

Large flow type Dust removal



Air coming from the IN side is filtered by the element after passing through the deflector.

Water drop removal type Water drop removal + Dust removal



Air coming from the IN side is rotated when passing through the fans in the deflector. Moisture is separated by centrifugal force.

Selectable filtration rating



5 μm

40 μm

80 μm

Washable

Washable

Easy to handle

The element and the bowl are in one piece. Replacement can be done in hand.



Superior visibility: 360°

Use of a transparent bowl guard makes it possible to check the element inside the case from the entire periphery.



Metal related corrosion does not occur.

Resin body does not rust.



Application Examples

- Collect particles before the ejector to lengthen the ejector life.
- To prevent cleaning water left on the workpiece from entering into the ejector when the pad picks up the workpiece.

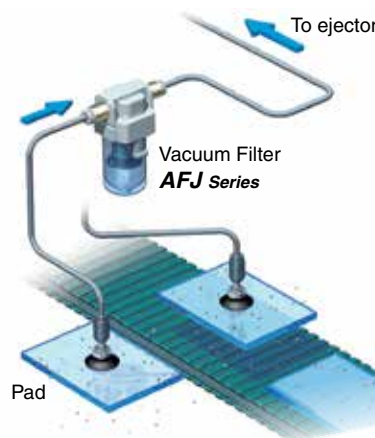

Application to ejector system

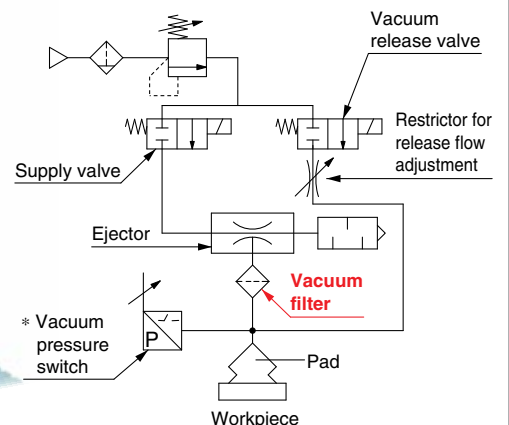

* If water droplets enter to the vacuum pressure switch, use a vacuum pressure switch for general fluid. For handling, refer to Common Precautions and the Operation Manual.

Moisture Control Tube

IDK Series

Coil shape added.

For details, refer to the **WEB catalog** or the catalog of each product.



CAT.NAS30-12

Prevents condensation

in piping

for small cylinders/air grippers.

Diffuses water vapor in the piping to the outside!

Water vapor

Water vapor

Water vapor

Linear shape

Suitable for applications where cylinders do not rotate.

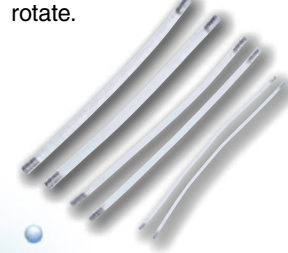

Coil shape

Reduces tube buckling of moving part.



Additional power supply and works are not necessary!

All you have to do is install the moisture control tube!!

No condensation

Moisture control tube

Condensation generated

General tube

Operating a small cylinder, air gripper, or air operated valve, etc. which has a small volume may cause condensation of water in the area near the actuator due to the volume ratio of the actuator volume and the operating piping volume.

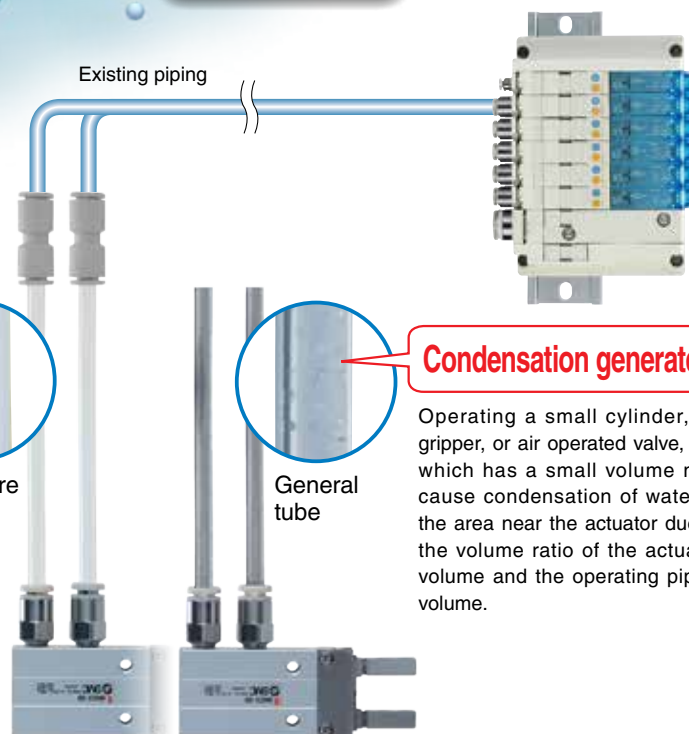

Water Regulator

WR110-□-X224/WR110-□-X215

For details, refer to the **WEB catalog** or the catalog of each product.



14-E627

Pressure adjustment of water line



Body material: Special brass

Model/Specifications

Model	WR110-□-X224	WR110-□-X215
Port size	Rc1/8, 1/4	Rc1/8, 1/4, NPT1/8, 1/4
Fluid*1	Water	
Ambient and fluid temperature	23 to 140°F [-5 to 60°C] (No freezing)	
Proof pressure	249 psi [1.72 MPa]	
Maximum operating pressure	116 psi [0.8 MPa]	
Set pressure range psi [MPa]	12 to 57 [0.08 to 0.39]	7 to 100 [0.05 to 0.69]
Pressure gauge port size	Rc1/8, 1/4	Rc1/8, 1/4, NPT1/8, 1/4
Weight (kg)	0.26	

*1: Cannot be used with deionized water.

*: When using a bracket, order the B21-1P separately.

*: The pressure gauge is optional (sold separately). Refer to the table on the right.



Pressure Gauge/Option (Sold separately)

For details, refer to the **WEB catalog**.

Model	Pressure range	Indication unit	Connection thread	Note
	psi [MPa]			
G46-4-01 to 02-SRB	0 to 58 [0 to 0.4]	MPa	R1/8 R1/4	—
G46-7-02-SRB	0 to 102 [0.7]			
G46-10-02-SRB	0 to 145 [1.0]			

*1: Do not apply more pressure than the max. pressure displayed. It may cause a malfunction.

Water Strainer

WF300 Series

For details, refer to the **WEB catalog** or the catalog of each product.



14-E628



Mesh:
100/70/50/25 mesh

Removal of foreign matter in water line

Specifications

Model	Port size	Fluid *1	Proof pressure	Max. operating pressure	Mesh	Ambient and fluid temperature	Weight
WF300-□	Rc1/4 3/8 1/2	Water	242 psi [1.67 MPa]	171 psi [1.18 MPa]	100 mesh	41 to 176°F [5 to 80°C]	0.29 kg
WF300-□-1-X204					70 mesh		
WF300-□-2-X204					50 mesh		
WF300-□-3-X204					25 mesh		

*1: Cannot be used with deionized water.

High-Precision Digital Pressure Switch

ZSE20(F)/ISE20 Series

For details, refer to the WEB catalog or the catalog of each product.



CAT.NAS100-114



While checking the measured value,

Main screen Measured value (Current pressure value)

setting is possible.

Sub screen Label (Display item), Set value (Threshold value)

Visualization of Setting Items

Set value (Threshold value)	P_1	Peak value	H_H
Hysteresis value	H_L	Bottom value	H -
Delay time	dt1		



Delay Time Fastest **1.5 ms*** or less **Current Consumption** **25 mA*** or less

* Select from 1.5 ms or less, 20 ms, 100 ms, 500 ms, 1000 ms, 2000 ms or 5000 ms.

* Reduced by approx. 60% in power saving mode.

Improved Operability

With a snapshot function for measured value reading

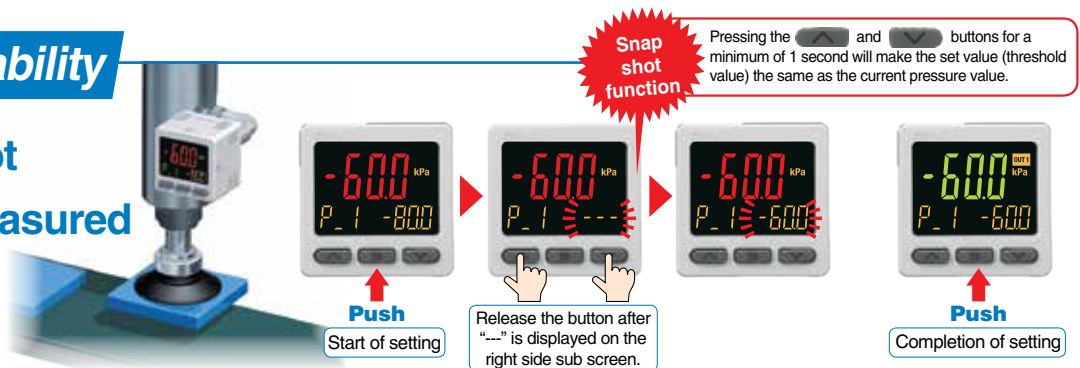

3 Setting Modes

- ① 3 Step Setting Mode
- ② Simple Setting Mode
- ③ Function Selection (detailed setting) Mode

Improved Operability

Visualization of Setting Items

Sub screen (label) shows the item to be set.

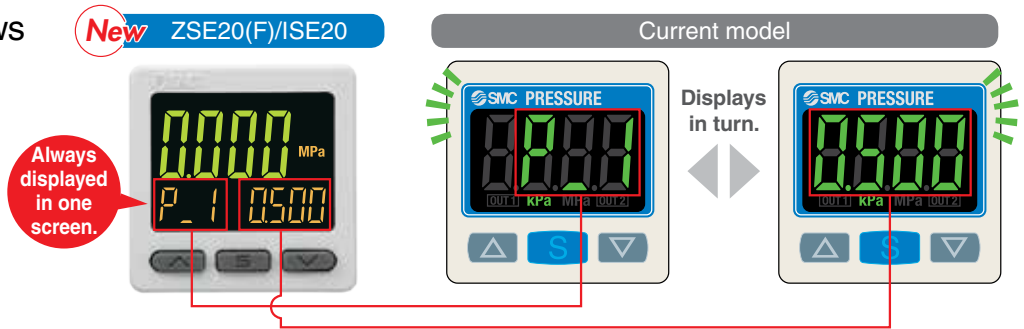

Always displayed in one screen.

Mode Examples

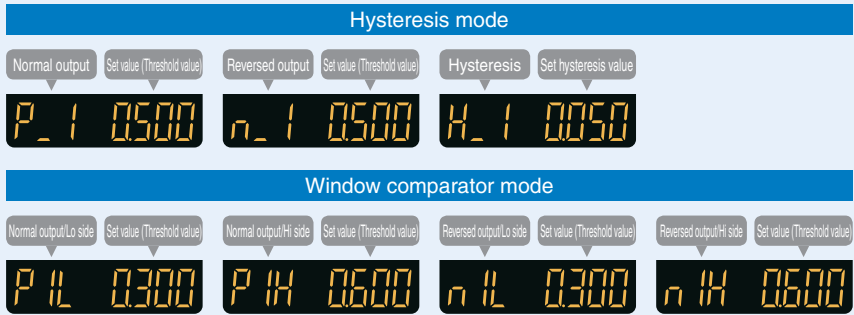

Simple 3 Step Setting

When S button is pressed, and the set value (P_1) is being displayed, the set value (Trigger level) can be set. When S button is pressed, and the hysteresis (H_1) is being displayed, the hysteresis can be set.

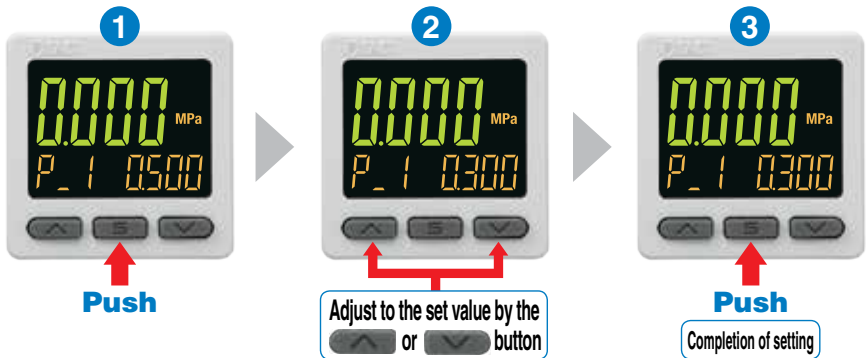

Easy Screen Switching

Setting is possible while checking the measured value.

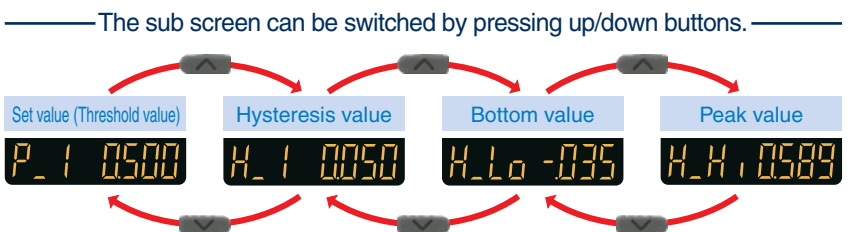
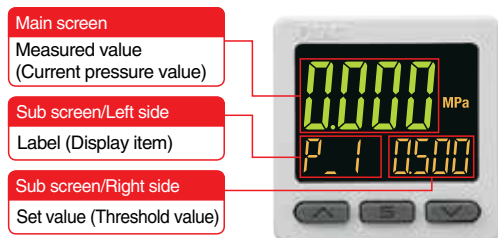

* One arbitrary display mode can be added by setting the function.

3 Setting Modes

Setting mode can be selected according to the purpose.

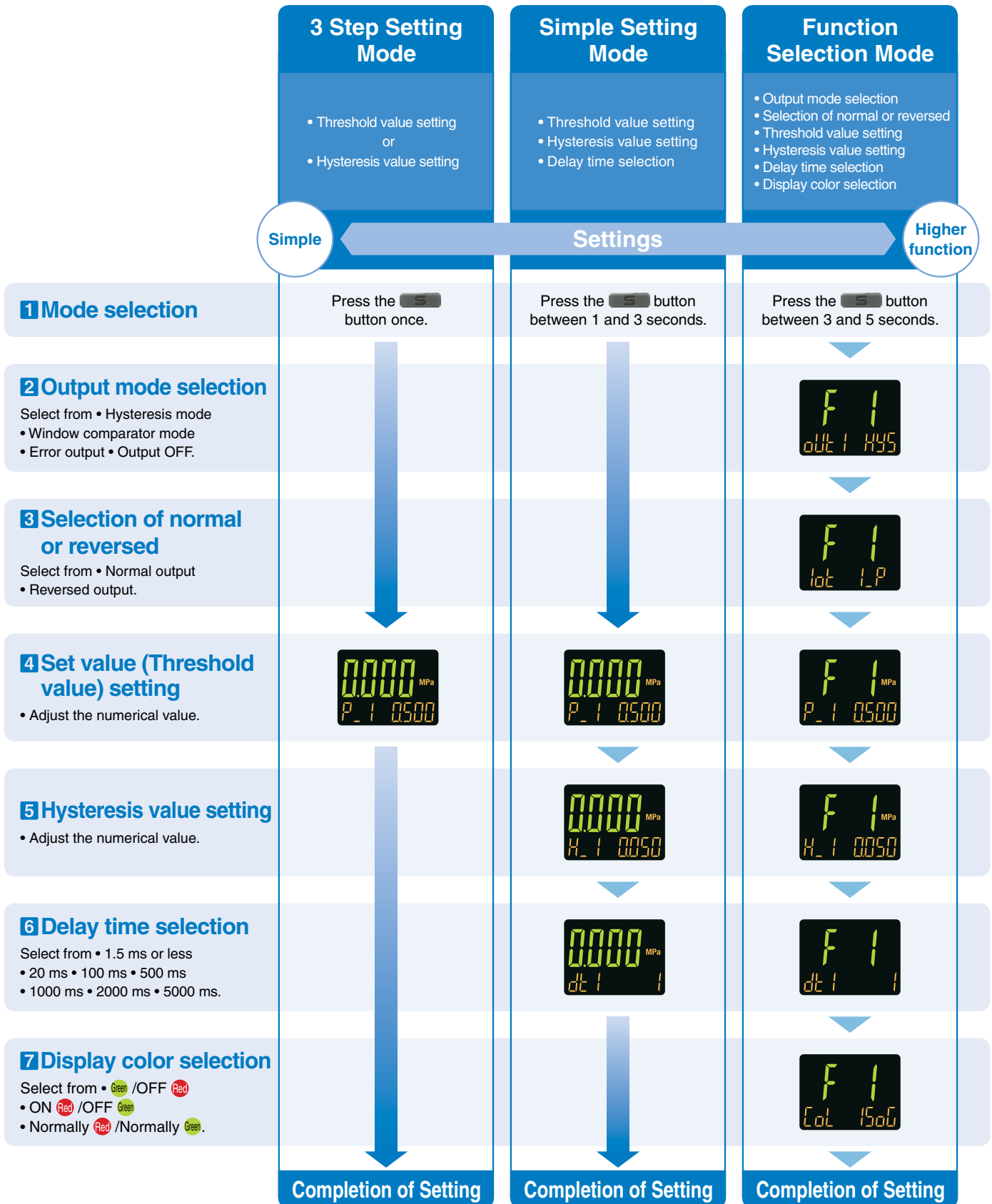

Other Sub Screen Display

Peak value or bottom value; or both values can be displayed in one screen!

* Peak and bottom values are maintained even if the power supply is cut.

* Combination of the displays shown above and the set values can be displayed on the sub screens on both sides.

Convenient Functions

- **Secret code setting function**

The key locking function keeps unauthorized persons from tampering with buttons.

- **Power saving function**

Power consumption is reduced by turning off the monitor. (Reduce power consumption by approx. 60%.)

- **Resolution switch function**

It reduces the monitor to flicker.

(Accuracy is not changed, only the displayed values.)

- **MPa/kPa switch function**

Vacuum, compound and/or positive pressure can be displayed in MPa or kPa.

Compact & Lightweight

- **Compact:** 17.5 mm shorter (When M5 female thread is used.)
- **Lightweight:** 21 g lighter (When M5 female thread is used.)

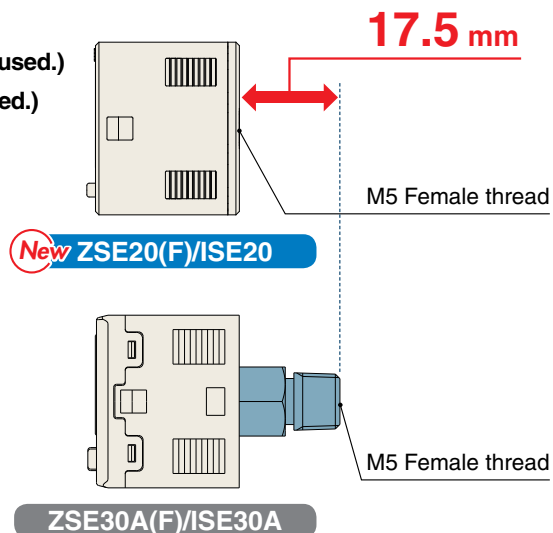

Mounting

Bracket configuration allows mounting in four orientations.

Bracket A

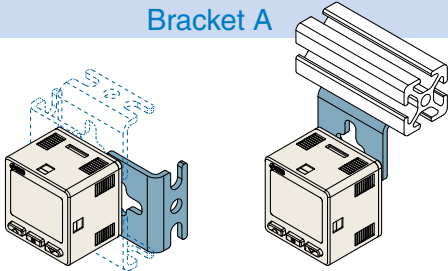

Mounting example

Bracket B

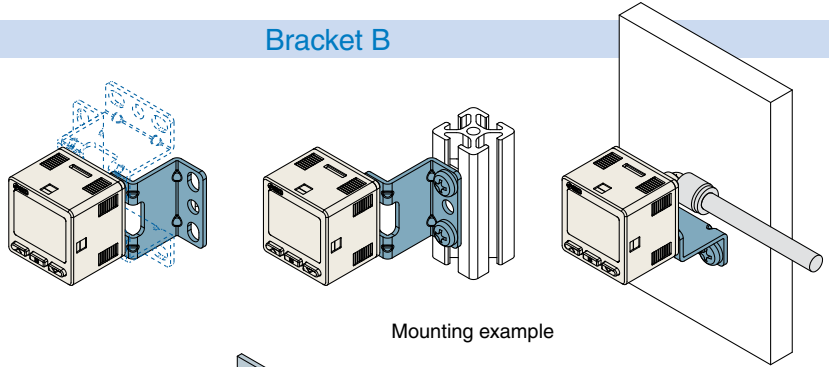

Mounting example

Panel mount



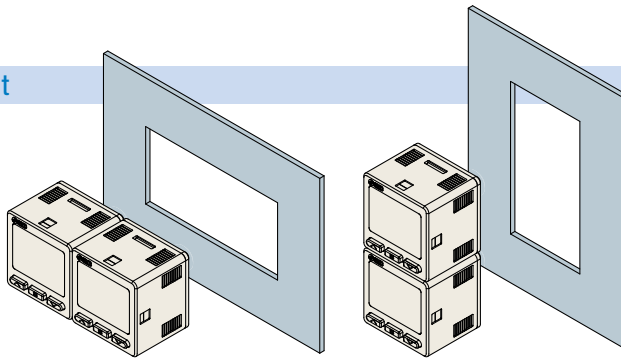

Mountable side by side without clearance

One opening!

- Reduced panel fitting labor
- Space saving

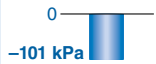

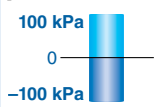
Introduction of Series

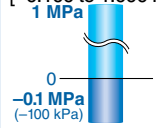
Series	Rated pressure range	Set pressure range	Withstand pressure	Smallest settable increment	Output	Piping
ZSE20 (Vacuum pressure) 	0.0 to -14.6 psi [0.0 to -101.0 kPa] 	1.45 to -15.2 psi [10.0 to -105.0 kPa]	72.5 psi [500 kPa]	0.0145 psi [0.1 kPa]		
ZSE20F (Compound pressure) 	-14.5 to 14.5 psi [-100.0 to 100.0 kPa] 	15.2 to -15.2 psi [-105.0 to 105.0 kPa]	72.5 psi [500 kPa]	0.0145 psi [0.1 kPa]	NPN or PNP open collector 1 output	M5 Female thread, R1/8, NPT1/8
ISE20 (Positive pressure) 	-14.5 to 145psi [-0.100 to 1.000 MPa] 	15.2 to 152 psi [-0.105 to 1.050 MPa]	218 psi [1.5 MPa]	0.145 psi [0.001 MPa]		

Speed Controller with Indicator

RoHS



AS-FS Series

- **Universal type added.**
- **Indicator window direction: 90° and 270° added.**

For details, refer to the **WEB catalog** or the catalog of each product.

CAT.NAS20-229

Numerical indication of knob rotation for flow rate

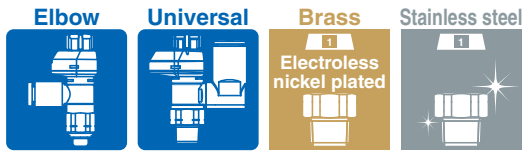

reduces flow setting time and setting errors!

Indicator window

Indicator window	Body size 1		Body size 2 or larger	
	Number of needle rotations	Indicator window	Number of needle rotations	Indicator window
1	1	1	1	1
2	2	2	2	2
⋮	⋮	⋮	⋮	⋮
8	8	10	10	10

8
Numerical indication of knob rotation

4 indicator window directions available

Indicator window direction: 0° Indicator window direction: 180°

New **New**

Indicator window direction: 90° Indicator window direction: 270°

Wide viewing angle



New series added!

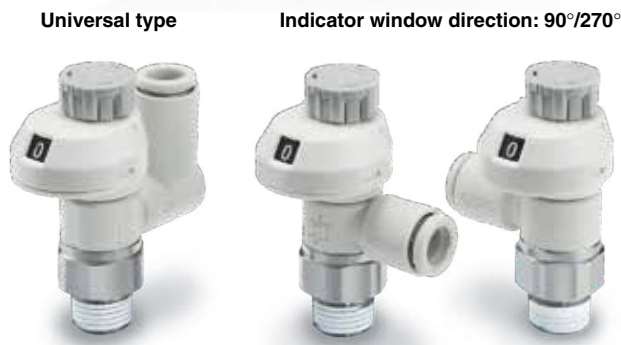

Card Motor

LAT3 Series

- Maximum stroke 50 mm added
- Maximum load mass improved
- Serial communication Modbus compatible



For details, refer to the WEB catalog or the catalog of each product.



CAT.NAS100-96

The transportation, pushing and length measurement systems have been miniaturized through the use of a linear motor.

Weight

130 g

Stroke:
10 mm

9

Thickness
mm



Maximum pushing force **6 N**

Pushing a miniature load

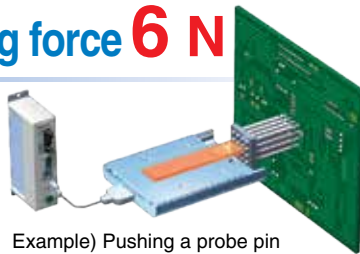

Example) Pushing a probe pin

Positioning repeatability

±5 μm

Positioning a workpiece

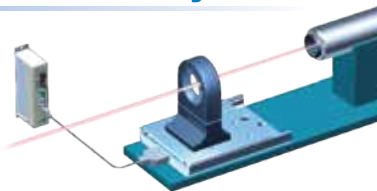

Example) Lens focusing

Pushing measurement accuracy

±10 μm

Parts measurement

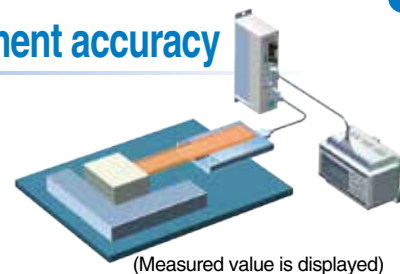

(Measured value is displayed)

Load mass: 100 g, Stroke: 5 mm

Maximum operating frequency

500 cpm

Rejection of non-conforming products etc.

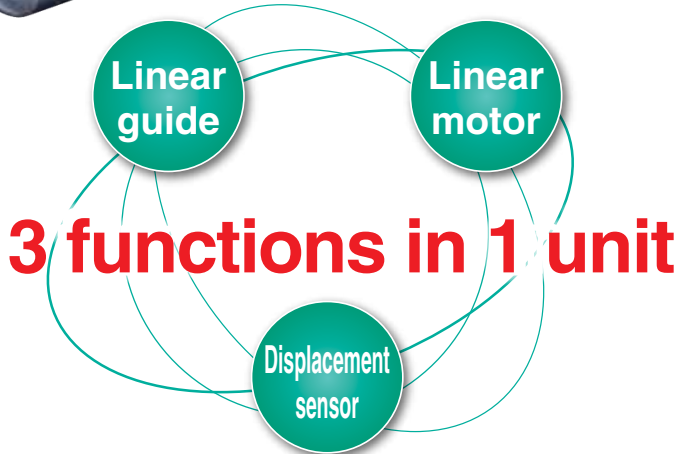
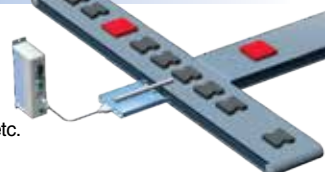

• Easy programming
(Cycle time entry)

Just input

3 parameters:

Positioning time,

Target position,

Load mass.



4 Axis Step Motor Controller



(Parallel I/O)

JXC73/83 Series

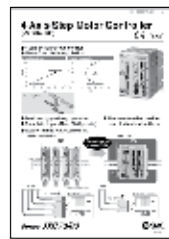

For details, refer to the WEB catalog or the catalog of each product.

14-E643

- 4 axis synchronous control
- Linear/circular interpolation

Linear interpolation

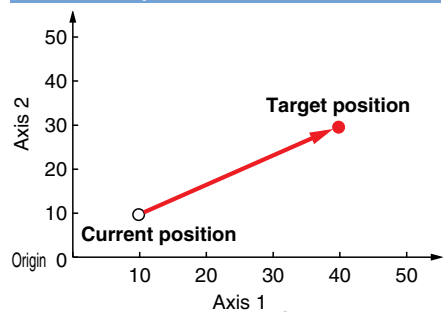

Circular interpolation

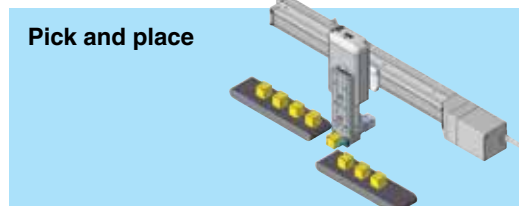
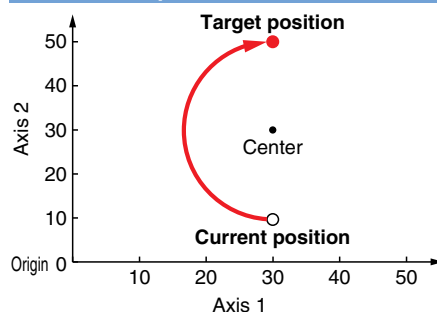

- Positioning/pushing operation
- Step data input (Max. 2048 points)
- Space saving, Reduced wiring

- Absolute/relative position coordinates instructions

LECP6 x 4 stations

170

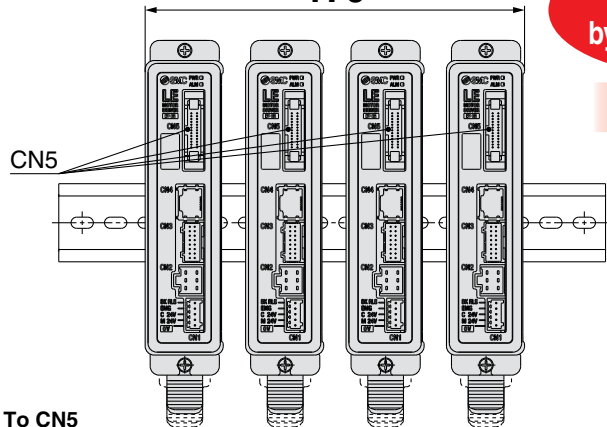

Footprint reduced by approx. 18%

JXC73/83

≈140

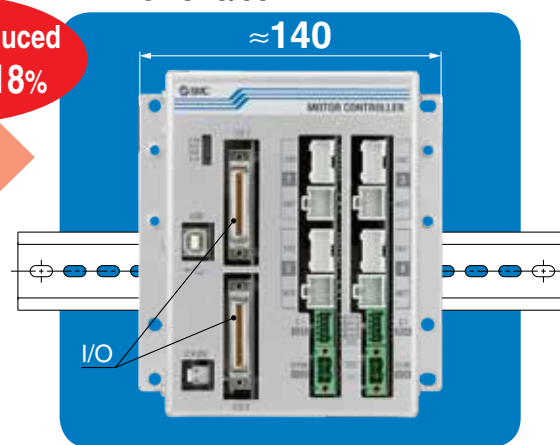

To CN5

I/O cable x 4

Provided by customer

PLC

Power supply for I/O signal
24 VDC

To I/O

I/O cable x 2

Provided by customer

PLC

Power supply for I/O signal
24 VDC



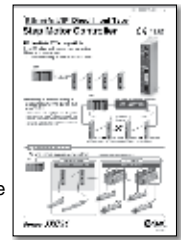

14-E642

Step Motor Controller

JXC91 Series

For details, refer to the **WEB catalog** or the catalog of each product.

■ EtherNet/IP™ compatible

- 10/100 Mbps high-speed communication
- Dual port connection
 - Transition wiring of communication cable



● Recovery is possible during a disconnection of the device level ring (DLR)!

In the device level ring type, even though the communication cable is disconnected in one location, EtherNet/IP™ communication can be continued, and the disconnected portion can be specified by the ring supervisor.

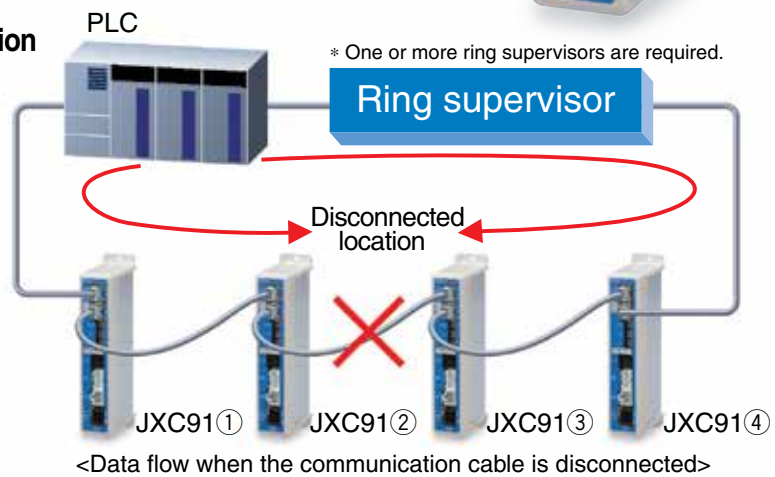

Application Example

Air and electric system configurations

Fieldbus network (EtherNet/IP™)

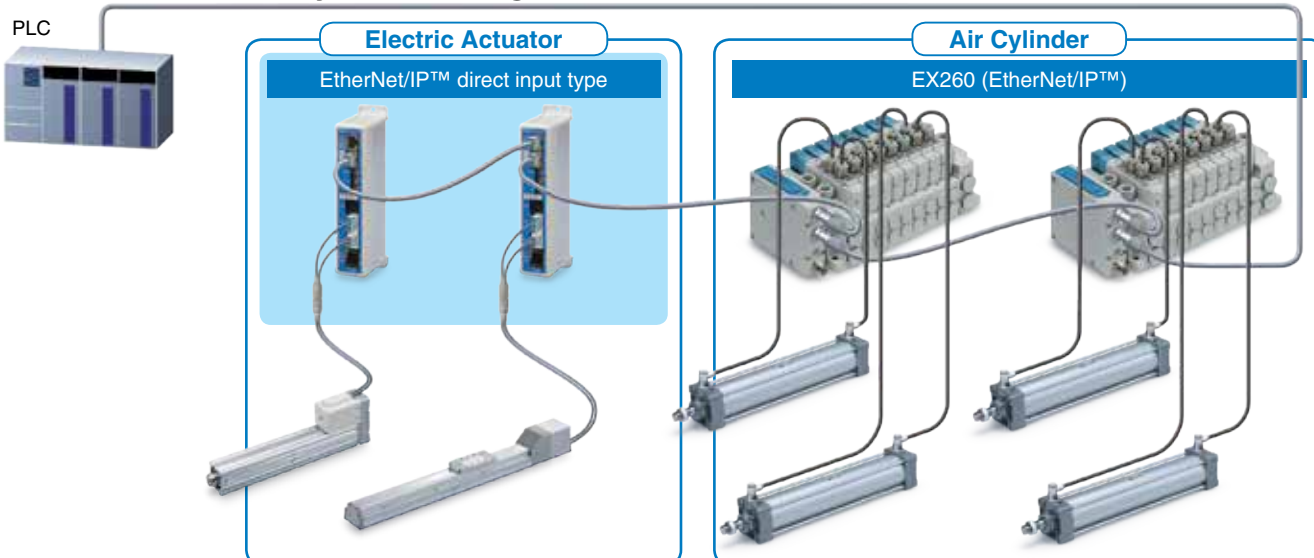



For details, refer to the WEB catalog or the catalog of each product.

15-E647

Rotary Joint

MQR-X229

Oldham coupling

- Operating pressure range:
14.5 to 102 psi
[-100 kPa to 0.7 MPa]
- Allowable rpm:
200 min⁻¹ (rpm)^{*1}
- Max. start-up rotation torque:
0.37 lbf·ft [0.50 N·m]^{*2} or less^{*3}
- Service life: **10 million** rotations
- Number of circuits: **8** circuits

*1 Reference value
*2 When no pressure applied.
*3 Under SMC's life test conditions.

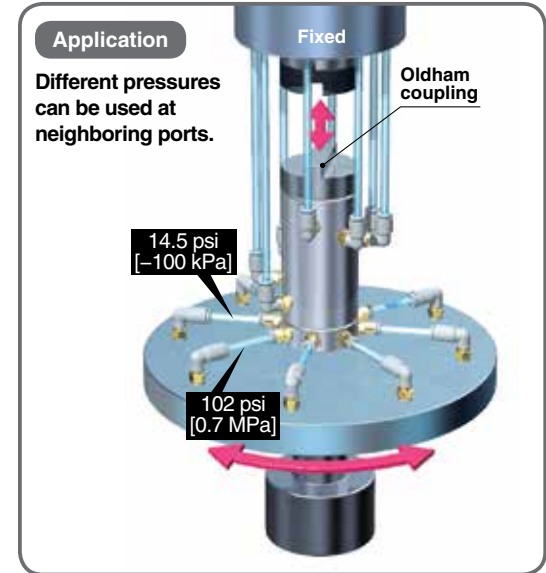

Large Size Booster Relay

XT240 Series

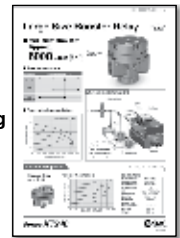

For details, refer to the WEB catalog or the catalog of each product.

14-E635

Maximum flow rate: Approx. 212 scfm [6000 L/min (ANR)]

Fluid temperature

Specification	Temperature range °F [°C]			
General	-22 [-30]	23 [-5]	140 [60]	212 [100]
High temperature				
Low temperature				

Flow rate characteristics

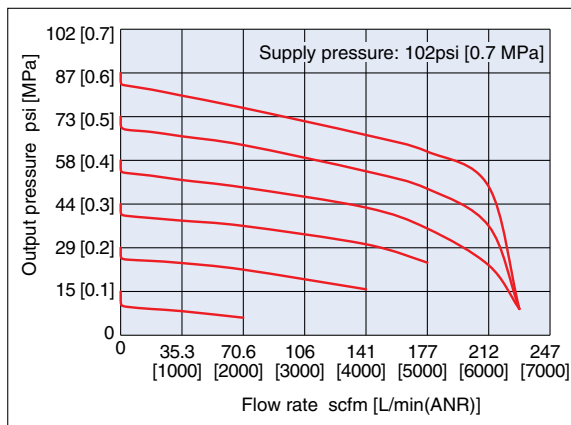

Thread type:
Rc, NPT

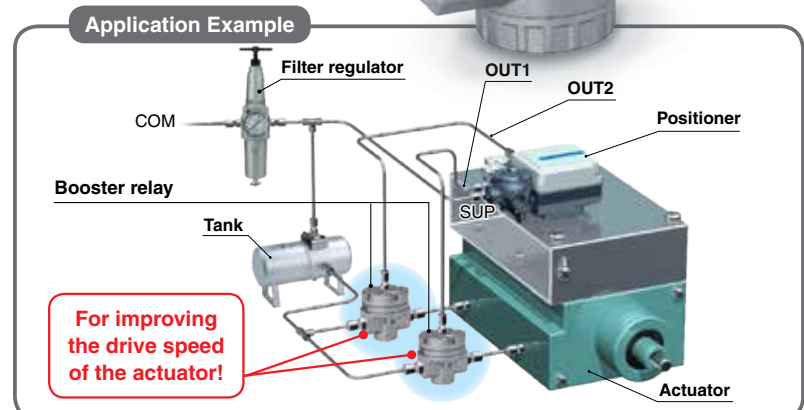

Global Manufacturing, Distribution and Service Network

Worldwide Subsidiaries

EUROPE

AUSTRIA SMC Pneumatik GmbH (Austria)	LATVIA SMC Pneumatics Latvia SIA
BELGIUM SMC Pneumatics N.V./S.A.	LITHUANIA SMC Pneumatics Lietuva, UAB
BULGARIA SMC Industrial Automation Bulgaria EOOD	NETHERLANDS SMC Pneumatics BV
CROATIA SMC Industrijska Automatika d.o.o.	NORWAY SMC Pneumatics Norway A/S
CZECH SMC Industrial Automation CZ s.r.o.	POLAND SMC Industrial Automation Polska Sp.z.o.o.
DENMARK SMC Pneumatik A/S	ROMANIA SMC Romania S.r.l.
ESTONIA SMC Pneumatics Estonia	RUSSIA SMC Pneumatik LLC.
FINLAND SMC Pneumatics Finland OY	SLOVAKIA SMC Priemyselná Automatizácia, s.r.o.
FRANCE SMC Pneumatique S.A.	SLOVENIA SMC Industrijska Avtomatika d.o.o.
GERMANY SMC Pneumatik GmbH	SPAIN / PORTUGAL SMC España, S.A.
GREECE SMC Hellas EPE	SWEDEN SMC Pneumatics Sweden AB
HUNGARY SMC Hungary Ipari Automatizálási Kft.	SWITZERLAND SMC Pneumatik AG
IRELAND SMC Pneumatics (Ireland) Ltd.	UK SMC Pneumatics (U.K.) Ltd.
ITALY SMC Italia S.p.A.	

ASIA

CHINA SMC (China) Co., Ltd.
HONG KONG SMC Pneumatics (Hong kong) Ltd.
INDIA SMC Pneumatics (India) Pvt. Ltd.
JAPAN SMC Corporation
MALAYSIA SMC Pneumatics (S.E.A.) Sdn. Bhd.
PHILIPPINES SMC Pneumatics (Philippines), Inc.
SINGAPORE SMC Pneumatics (S.E.A.) Pte. Ltd.
SOUTH KOREA SMC Pneumatics Korea Co., Ltd.
TAIWAN SMC Pneumatics (Taiwan) Co., Ltd.
THAILAND SMC Thailand Ltd.

NORTH AMERICA

CANADA SMC Pneumatics (Canada) Ltd.
MEXICO SMC Corporation (Mexico) S.A. DE C.V.
USA SMC Corporation of America

SOUTH AMERICA

ARGENTINA SMC Argentina S.A.
BOLIVIA SMC Pneumatics Bolivia S.R.L.
BRAZIL SMC Pneumaticos do Brazil Ltda.
CHILE SMC Pneumatics (Chile) S.A.
PERU SMC Corporation Peru S.A.C.
VENEZUELA SMC Neumatica Venezuela S.A.

OCEANIA

AUSTRALIA SMC Pneumatics (Australia) Pty. Ltd.
NEW ZEALAND SMC Pneumatics (N.Z.) Ltd.

U.S. & Canadian Sales Offices

WEST

Austin
Dallas
Los Angeles
Phoenix
Portland
San Francisco

CENTRAL

Chicago
Cincinnati
Cleveland
Detroit
Indianapolis
Milwaukee
Minneapolis
St. Louis

EAST

Atlanta
Birmingham
Boston
Charlotte
Nashville
New Jersey
Rochester
Tampa

CANADA

Montreal
Toronto
Vancouver
Windsor

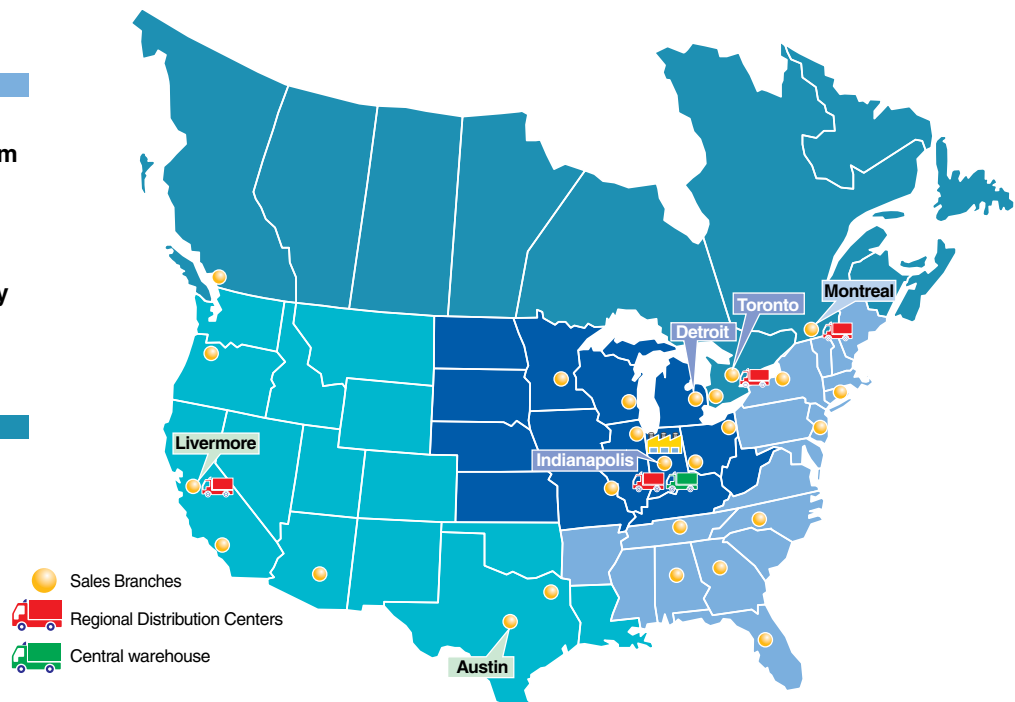

SMC Corporation of America
10100 SMC Blvd., Noblesville, IN 46060
www.smcusa.com

SMC Pneumatics (Canada) Ltd.
www.smc Pneumatics.ca

(800) SMC.SMC1 (762-7621)
e-mail: sales@smcusa.com
International inquiries: www.smcworld.com

