



N304-EX

Air Cylinder

NCA1 Series



NFPA Industrial Interchangeable Pneumatic Cylinders
Medium Duty 5" to 8"
Heavy Duty 1.5" to 14"

PNEUMATIC CYLINDERS

SERIES NCA1 - TABLE OF CONTENTS

Description	Page No
Specifications	
Material / Technical	1
How To Order	
NCA1 - ϕ 1.5 to ϕ 14" Heavy Duty	2
NCA1 - ϕ 5 to ϕ 8" Medium Duty	3
Dimensions	
ϕ 1.5 - ϕ 6 MF1 w/Front Rectangular Flange	4
ϕ 1.5 - ϕ 6 MF2 w/Rear Rectangular Flange	4
ϕ 1.5 - ϕ 6 MF5 w/Front Square Flange	5
ϕ 1.5 - ϕ 6 MF6 w/Rear Square Flange	5
ϕ 1.5 - ϕ 6 MP1 w/Double Rear Clevis	6
ϕ 1.5 - ϕ 6 MP2 w/Double Detachable Rear Clevis	6
ϕ 1.5 - ϕ 6 MP3 w/Cap Fixed Eye	7
ϕ 1.5 - ϕ 6 MP4 w/Single Detachable Rear Clevis	7
ϕ 1.5 - ϕ 6 MS1 w/Foot Mount	8
ϕ 1.5 - ϕ 6 MS2 w/Side Lug	8
ϕ 1.5 - ϕ 6 MS3 w/Centerlug	9
ϕ 1.5 - ϕ 6 MS4 w/Side Tapped	9
ϕ 1.5 - ϕ 6 MS7 w/Front Lug Mount	10
ϕ 1.5 - ϕ 6 MT1 w/Head Trunnion	10
ϕ 1.5 - ϕ 6 MT2 w/Rear Trunnion	11
ϕ 1.5 - ϕ 6 MT4 w/Center Trunnion	11
ϕ 1.5 - ϕ 6 MX1 w/Extended Tie-Rods/Both Ends	12
ϕ 1.5 - ϕ 6 MX2 w/Extended Tie-Rods/Cap	12
ϕ 1.5 - ϕ 6 MX3 w/Extended Tie-Rods/Head	13
ϕ 8 - ϕ 14 ME3 w/Head Square Mount	13
ϕ 8 - ϕ 14 ME4 w/Cap Square Mount	14
ϕ 8 - ϕ 14 MP1 w/Double Rear Clevis	14
ϕ 8 - ϕ 14 MP2 w/Double Detachable Rear Clevis	15
ϕ 8 - ϕ 14 MP3 w/Cap Fixed Eye	15
ϕ 8 - ϕ 14 MP4 w/Single Detachable Rear Clevis	15
ϕ 8 - ϕ 14 MS1 w/Foot Mount	16
ϕ 8 - ϕ 14 MS2 w/Side Lug	16
ϕ 8 - ϕ 14 MS3 w/Center line Lug	16
ϕ 8 - ϕ 14 MS4 w/Side Tapped	17
ϕ 8 - ϕ 14 MS7 w/Front Lug Mount	17
ϕ 8 - ϕ 14 MT1 w/Head Trunnion	17
ϕ 8 - ϕ 14 MT2 w/Rear Trunnion	18
ϕ 8 - ϕ 14 MT4 w/Center Trunnion	18
ϕ 8 - ϕ 14 MX1/MX2/MX3 w/Extended Tie-Rods	19
ϕ 1.5 - ϕ 6 NCA1-W Double Rod	19
ϕ 8 - ϕ 14 NCA1-W Double Rod	19
Engineering Specifications	
Push Stroke	20
Pull Stroke	20
Oversize Piston Rods	20
Stroke Factors	21
Stop Tube	21
Options	
Auto Switch Options	22
Table of Thread Form Codes / XA Options	22
Option XC3 - Port and Cushion Location	23
Construction / Parts List / Seal Kit	23
Accessories	
Eye Brackets, Clevis Brackets, Rod Clevises, Rod Eyes, Pin, Alignment Couplers, Rod Jam Nut	24

Air Cylinder Series NCA1-EX

MATERIAL SPECIFICATIONS

MEDIUM DUTY XTAT			
Bore Size	5	6	8
Barrel -			
Aluminum	Std	Std	Std
Composite Fiber	Opt	Opt	Opt
Head/Cap - Aluminum	Std	Std	N/A
Head/Cap - Steel	N/A	N/A	Std
Piston - Aluminum	Std	Std	Std
Gland Bushing	Bronze Material		

Note Material Specifications for above: Aluminum; 6061-T6, Steel; ASTM A36, Stainless Steel; 316.

TECHNICAL SPECIFICATIONS

Fluid	Air / Hydraulic* (250psi non-shock)
Lubrication	Non Lube
Max operating Pressure	250 PSI
Min Operating Pressure	5 PSI
Ambient & Fluid Temp	40-140°F / 5-60°C

Please note for Hydraulic Service please order the H option as denoted in the How to Order breakdown on pgs 2 & 3

HEAVY DUTY XTST

Bore Size	1.5-4	5	6	8	10	12	14
Barrel -							
Steel	Std	Std	Std	Std	Std	Std	Std
Composite Fiber	Opt	Opt	Opt	Opt	Opt	Opt	Opt
Head/Cap - Steel	Std	Std	Std	Std	N/A	Std	Std
Piston - Aluminum	Std	Std	Std	Std	N/A	N/A	N/A
Piston - Steel	N/A	N/A	N/A	N/A	Std	Std	Std
Gland Bushing	Bronze Material						

Note Material Specifications for above: Aluminum; 6061-T6, Steel; ASTM A36, Stainless Steel; 316,

N/A - Not Available; please contact SMC Customer Service

OPT - Optional; see How to Order

CORROSION RESISTANT XTSS

Barrel	Stainless Steel
	Composite Tube Optional
Head/Cap	Stainless Steel
Piston	Aluminum
Tie Rods	Stainless Steel
Gland Bushing	Delrin

Note Material Specifications for above: Aluminum; 6061-T6, Stainless Steel; 316,

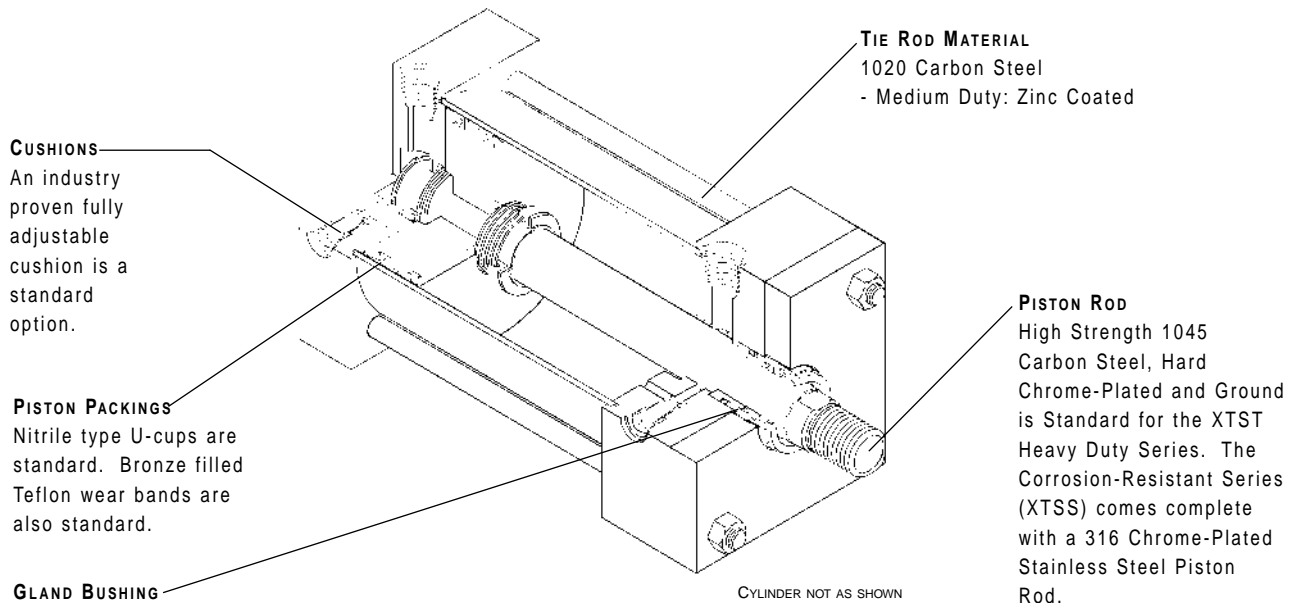

**SERIES NCA1 HEAVY DUTY
PNEUMATIC CYLINDERS
BORE SIZES 1.5 ~ 14"**

- Steel and Stainless Steel Construction
- Replaceable Rod Gland Design
- Auto Switch Sensing Option (Stainless and Composite Tube Only)
- Hydraulic Service / 250PSI Non Shock (H Option)
- Non Rotating Piston Rod & Through Hole Rod Types Available
- Full Range of NFPA Interchangeable Mounting Configurations
 - Mounting Dimensions are in accordance with ANSI/(NFPA) T3.6.7 R2-1996, Fluid Power Systems and products - Square Head Industrial Cylinders - Mounting Dimensions.

**How To
ORDER**



- AUTO SWITCH**
-Standard
 - DAuto Switch capable (Stainless and Composite tube only)
- STYLE**
-Standard Cylinder
 - WDouble Rod (Please see Page 19 for Mounting Information)
 - K Non-rotating Piston Rod (5 to 14"ø)
- MOUNTING / SINGLE ROD ONLY**
- EA ... **ME3** - Head Square Mount (8 to 14"ø)
 - EB ... **ME4** - Cap Square Mount (8 to 14"ø)
 - F ... **MF1** - Front Flange (1.5 to 6"ø)
 - G ... **MF2** - Rear Flange (1.5 to 6"ø)
 - M ... **MF5** - Front Flange (1.5 to 6"ø)
 - N ... **MF6** - Rear Flange (1.5 to 6"ø)
 - X ... **MP1** - Double Rear Clevis (1.5 to 14"ø)
 - D ... **MP2** - Double Detachable Rear Clevis/Female (1.5 to 14"ø)
 - E ... **MP3** - Cap Fixed Eye (1.5 to 14"ø)
 - C ... **MP4** - Single Detachable Rear Clevis/Male (1.5 to 14"ø)
 - L ... **MS1** - Foot Mount (1.5 to 14"ø)
 - S ... **MS2** - Side Lug (1.5 to 14"ø)
 - O ... **MS3** - Centerline Lug (1.5 to 14"ø)
 - R ... **MS4** - Side-Tapped (1.5 to 14"ø)
 - P ... **MS7** - Front Lug Mount (1.5 to 14"ø)
 - U ... **MT1** - Rod End Trunnion (1.5 to 14"ø)
 - J ... **MT2** - Cap Trunnion (1.5 - 14"ø)
 - T ... **MT4** - Center Trunnion (1.5 to 14"ø) *See below
 - B ... **MX0** - Basic/No Mount (1.5 to 14"ø)
 - BA ... **MX1** - Extended Tie-Rods; Head/Cap (1.5 to 14"ø)
 - BB ... **MX2** - Extended Tie-Rods; Cap (1.5 to 14"ø)
 - BC ... **MX3** - Extended Tie-Rods; Head (1.5 to 14"ø)

- CONSTRUCTION TYPE**
(PLEASE SEE PAGE 1 FOR CONSTRUCTION DETAILS)
- ST ...Steel Construction (1.5-14"ø)
 - SS ...All Stainless Steel (1.5-14"ø)
 - SCT ...Steel w/ Composite Tube (1.5 - 14"ø)
 - SSCT...Stainless Steel w/ Composite Tube (1.5- 14"ø)

- OPTIONS**
- A.....Special Rod Thread (See Page 22)
 - B5Oversized Rod (See Chart below)
 - B6High Temperature *
 - C3Port and Cushion Location (see Page 23)
 - C6Stainless Steel Piston Rod (Std. on XTSS series)
 - C8Adjustable Stroke Extended Piston Rod *
 - C9Adjustable Stroke Return Piston Rod *
 - C10 ...Dual Operation/Double Piston Rod *
 - C11 ...Dual Operation/Single Piston Rod *
 - C12 ...Tandem Cylinder*
- * (Contact SMC Customer Service)

- NO OF SWITCHES**
-2 Pieces
 - S1 Piece
 - nNumber Of Switches

- ROD BOOT**
-Without Boot
 - KNeoprene Boot

- AIR CUSHION**
-Both Ends
 - NNone
 - HCap End
 - RRod End
- *Note: Non Adjustable Cushions are available on units above 4" Bore
Please Consult SMC Customer Service
**Note: Cushions not recommended for Strokes below 3"

AUTO SWITCH
For Switch information for steel tube please contact SMC customer service.
See Pg 22 for auto switch options when using composite or stainless steel tube.

How To Order MT4 With Non Standard XI Dimension

NCA1 T ○ - ○ - X46US (XI = Total Inches) T ○
Specify XI Dimension in inches Construction Type

- STYLE**
-Pneumatic
 - HHydraulic

BORE SIZE	STD. ROD ø	STD. ROD THREAD
1501.5"	5/8"	7/16-20
2002"	5/8"	7/16-20
2502.5"	5/8"	7/16-20
3253.25"	1"	3/4-16
4004"	1"	3/4-16
5005"	1"	3/4-16
6006"	1-3/8"	1-14
8008"	1-3/8"	1-14
100010"	1-3/4"	1 1/4-12
120012"	2"	1 1/2-12
140014"	2-1/2"	1 7/8-12

STANDARD STROKE
Inches
Example: 04 = 4" Stroke

STROKE
Hundredths Of An Inch
Example: 25 = 0.25 (1/4) Inch Stroke

OPTION OVERSIZED ROD - XB5 OPTION
When ordering an oversized rod, please order the following way to represent the rod size required.

- XB5**
- E 1"
 - G 1 3/8"
 - H 1 3/4"
 - J 2"
 - K 2 1/2"
 - L 3"
 - M 3 1/2"
 - Z Please consult SMC Customer Service for larger sizes.

Up to 32" Bore available
Please contact SMC Customer Service
REFER TO PAGE 22 FOR OPTIONAL ROD THREADS

**SERIES NCA1 MEDIUM DUTY LARGE BORE
PNEUMATIC CYLINDERS
BORE SIZES 5 ~ 8"**

- Aluminum Construction
- Replaceable Rod Gland Design
- Auto Switch Capable
- Hydraulic Service / 250PSI Non-Shock (H Option)
- Full Range of NFPA Interchangeable Mounting Configurations
 - Mounting Dimensions are in accordance with ANSI(NFPA) T3.6.7 R2-1996, Fluid Power Systems and products - Square Head Industrial Cylinders - Mounting Dimension

**How To
ORDER**

NC A1 ———— X T

AUTO SWITCH
 -Standard
 DAuto Switch capable

STYLE
 -Standard
 WDouble Rod (Please see Page 19 for Mounting Information)
 KNon-Rotating Piston Rod

MOUNTING / SINGLE ROD ONLY

- EA ... **ME3** - Head Square Mount (8" only)
- EB ... **ME4** - Cap Square Mount (8" only)
- F ... **MF1** - Front Flange (5 to 6"ø)
- G ... **MF2** - Rear Flange (5 to 6"ø)
- M ... **MF5** - Front Flange (5 to 6"ø)
- N ... **MF6** - Rear Flange (5 to 6"ø)
- X ... **MP1** - Double Rear Clevis (5 to 8"ø)
- D ... **MP2** - Double Detachable Rear Clevis/Female (5 to 8"ø)
- E ... **MP3** - Cap Fixed Eye (8"ø only)
- C ... **MP4** - Single Detachable Rear Clevis/Male (5 to 8"ø)
- L ... **MS1** - Foot Mount (5 to 8"ø)
- S ... **MS2** - Side Lug (8" only)
- O ... **MS3** - Centerline Lug (8" only)
- R ... **MS4** - Side-Tapped (5 to 8"ø)
- P ... **MS7** - Front Lug Mount (5 to 8"ø)
- U ... **MT1** - Head Trunnion (5 to 8"ø)
- J ... **MT2** - Cap Trunnion (5 to 8"ø)
- T ... **MT4** - Center Trunnion (5 to 8"ø) *See below
- B ... **MX0** - Basic / No Mount (5 to 8"ø)
- BA ... **MX1** - Extended Tie-Rods; Head/Cap (5 to 8"ø)
- BB ... **MX2** - Extended Tie-Rods; Cap (5 to 8"ø)
- BC ... **MX3** - Extended Tie-Rods; Head (5 to 8"ø)

CONSTRUCTION TYPE
 (PLEASE SEE PAGE 1 FOR CONSTRUCTION DETAILS)
 AT ...Aluminum Tube (5-8"ø)
 ACT ...Composite tube (5-8"ø)

OPTIONS

- ASpecial Rod Thread (Please see Page 22)
 - B5Oversized Rod (See Chart below for Bore Sizes above 4")
 - B6High Temperature *
 - C3Port and Cushion Location (see Page 23)
 - C6Stainless Steel Piston Rod
 - C8Adjustable Stroke Extended Piston Rod *
 - C9Adjustable Stroke Return Piston Rod *
 - C10 ...Dual Operation/Double Piston Rod *
 - C11 ...Dual Operation/Single Piston Rod *
 - C12 ...Tandem Cylinder*
- * Contact SMC Customer Service

NO OF SWITCHES

-2 Pieces
- S1 Piece
- nNumber of Switches

ROD BOOT

-Without Boot
- KNeoprene Boot

AIR CUSHION

-Both Ends
- NNone
- HCap End
- RRod End

AUTO SWITCH

See Page 22 for Auto Switch Options

*Note: Non Adjustable Cushions are available Please Consult SMC Customer Service
 **Note: Cushions not recommended for Strokes below 3"

STROKE

Hundredths Of An Inch
 Example: 25 = 0.25 (1/4) Inch Stroke

STANDARD STROKE

Inches
 Example: 04 = 4" Stroke

OPTION

OVERSIZED ROD - XB5 OPTION

When ordering an oversized rod, please order the following way to represent the rod size required.

XB5

- T
- G 1 3/8"
- H 1 3/4"
- J 2"
- K 2 1/2"
- L 3"
- M 3 1/2"
- Z Please contact SMC Customer Service for larger sizes

How To Order MT4 With Non Standard XI Dimension

NCA1 T ○ - ○ - X46US (XI = Total Inches) T ○

Specify XI Dimension in inches

Construction Type

STYLE
 -Pneumatic
 HHydraulic

BORE SIZE	STD. ROD ø	STD. ROD THREAD
5005"	1"	3/4-16
6006"	1-3/8"	1-14
8008"	1-3/8"	1-14

REFER TO PAGE 22 FOR OPTIONAL ROD THREADS

MF1 $\varnothing 1.5" \sim 6"$
WITH FRONT RECTANGULAR FLANGE

BORE	Rod \varnothing MM	KK SM	A	B	V	W	Y	ADD LB	STROKE P
1 1/2	5/8	7/16-20	3/4	1.125	1/4	5/8	1 15/16	4	2 1/4
1 1/2	1	3/4-16	1 1/8	1.5	1/2	1	2 5/16	4	2 1/4
2	5/8	7/16-20	3/4	1.125	1/4	5/8	1 15/16	4	2 1/4
2	1	3/4-16	1 1/8	1.5	1/2	1	2 5/16	4	2 1/4
2	1 3/8	1-14	1 5/8	2	5/8	1 1/4	2 9/16	4	2 1/4
2 1/2	5/8	7/16-20	3/4	1.125	1/4	5/8	1 15/16	4 1/8	2 3/8
2 1/2	1	3/4-16	1 1/8	1.5	1/2	1	2 5/16	4 1/8	2 3/8
2 1/2	1 3/8	1-14	1 5/8	2	5/8	1 1/4	2 9/16	4 1/8	2 3/8
3 1/4	1	3/4-16	1 1/8	1.5	1/4	3/4	2 3/8	4 7/8	2 5/8
3 1/4	1 3/8	1-14	1 5/8	2	3/8	1	2 5/8	4 7/8	2 5/8
4	1	3/4-16	1 1/8	1.5	1/4	3/4	2 3/8	4 7/8	2 5/8
4	1 3/8	1-14	1 5/8	2	3/8	1	2 5/8	4 7/8	2 5/8
5	1	3/4-16	1 1/8	1.5	1/4	3/4	2 5/16	5 1/8	2 7/8
5	1 3/8	1-14	1 5/8	2	3/8	1	2 9/16	5 1/8	2 7/8
5	1 3/4	1 1/4-12	2	2.375	1/2	1 1/4	2 13/16	5 1/8	2 7/8
6	1 3/8	1-14	1 5/8	2	1/4	7/8	2 13/16	5 3/4	3 1/8
6	1 3/4	1 1/4-12	2	2.375	3/8	1 1/8	3 1/16	5 3/4	3 1/8
6	2	1 1/2-12	2 1/4	2.625	3/8	1 1/4	3 3/16	5 3/4	3 1/8

BORE	E	EE(NPT)	F	FB	G	J	K	R	TF	UF
1 1/2	2	3/8	3/8	5/16	2	1	1/4	1.43	2 3/4	3 3/8
2	2 1/2	3/8	3/8	3/8	2	1	5/16	1.84	3 3/8	4 1/8
2 1/2	3	3/8	3/8	3/8	2	1 1/8	5/16	2.19	3 7/8	4 5/8
3 1/4	3 3/4	1/2	5/8	7/16	2 1/4	1 1/4	3/8	2.76	4 11/16	5 1/2
4	4 1/2	1/2	5/8	7/16	2 1/4	1 1/4	3/8	3.32	5 7/16	6 1/4
5	5 1/2	1/2	5/8	9/16	2 1/4	1 1/2	7/16	4.10	6 5/8	7 5/8
6	6 1/2	3/4	3/4	9/16	2 3/4	1 5/8	7/16	4.88	7 5/8	8 5/8

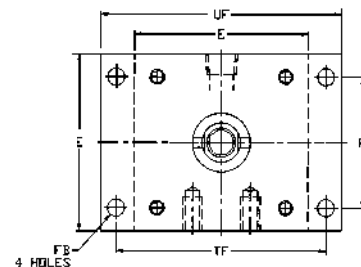
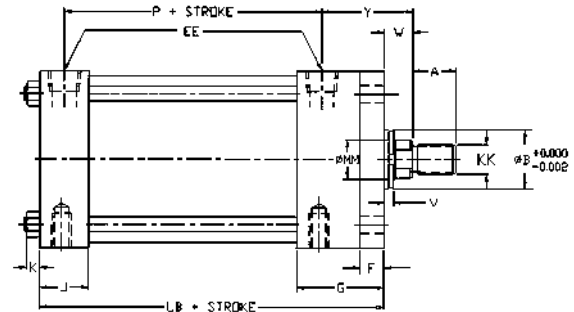

MF2 $\varnothing 1.5" \sim 6"$
WITH REAR RECTANGULAR FLANGE

BORE	Rod \varnothing MM	KK SM	A	B	V	W	Y	ADD LB	STROKE P
1 1/2	5/8	7/16-20	3/4	1.125	1/4	5/8	1 15/16	4	2 1/4
1 1/2	1	3/4-16	1 1/8	1.5	1/2	1	2 5/16	4	2 1/4
2	5/8	7/16-20	3/4	1.125	1/4	5/8	1 15/16	4	2 1/4
2	1	3/4-16	1 1/8	1.5	1/2	1	2 5/16	4	2 1/4
2	1 3/8	1-14	1 5/8	2	5/8	1 1/4	2 9/16	4	2 1/4
2 1/2	5/8	7/16-20	3/4	1.125	1/4	5/8	1 15/16	4 1/8	2 3/8
2 1/2	1	3/4-16	1 1/8	1.5	1/2	1	2 5/16	4 1/8	2 3/8
2 1/2	1 3/8	1-14	1 5/8	2	5/8	1 1/4	2 9/16	4 1/8	2 3/8
3 1/4	1	3/4-16	1 1/8	1.5	1/4	3/4	2 3/8	4 7/8	2 5/8
3 1/4	1 3/8	1-14	1 5/8	2	3/8	1	2 5/8	4 7/8	2 5/8
4	1	3/4-16	1 1/8	1.5	1/4	3/4	2 3/8	4 7/8	2 5/8
4	1 3/8	1-14	1 5/8	2	3/8	1	2 5/8	4 7/8	2 5/8
5	1	3/4-16	1 1/8	1.5	1/4	3/4	2 5/16	5 1/8	2 7/8
5	1 3/8	1-14	1 5/8	2	3/8	1	2 9/16	5 1/8	2 7/8
5	1 3/4	1 1/4-12	2	2.375	1/2	1 1/4	2 13/16	5 1/8	2 7/8
6	1 3/8	1-14	1 5/8	2	1/4	7/8	2 13/16	5 3/4	3 1/8
6	1 3/4	1 1/4-12	2	2.375	3/8	1 1/8	3 1/16	5 3/4	3 1/8
6	2	1 1/2-12	2 1/4	2.625	3/8	1 1/4	3 3/16	5 3/4	3 1/8

BORE	E	EE(NPT)	F	FB	G	J	K	R	TF	UF
1 1/2	2	3/8	3/8	5/16	2	1	1/4	1.43	2 3/4	3 3/8
2	2 1/2	3/8	3/8	3/8	2	1	5/16	1.84	3 3/8	4 1/8
2 1/2	3	3/8	3/8	3/8	2	1 1/8	5/16	2.19	3 7/8	4 5/8
3 1/4	3 3/4	1/2	5/8	7/16	2 1/4	1 1/4	3/8	2.76	4 11/16	5 1/2
4	4 1/2	1/2	5/8	7/16	2 1/4	1 1/4	3/8	3.32	5 7/16	6 1/4
5	5 1/2	1/2	5/8	9/16	2 1/4	1 1/2	7/16	4.10	6 5/8	7 5/8
6	6 1/2	3/4	3/4	9/16	2 3/4	1 5/8	7/16	4.88	7 5/8	8 5/8

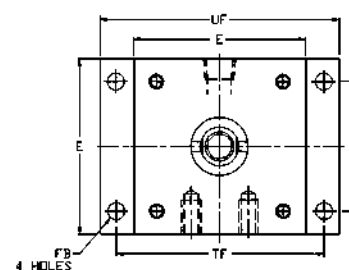
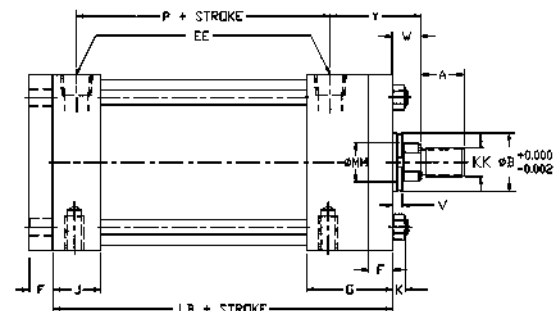

MF5 $\varnothing 1.5'' \sim 6''$
WITH FRONT SQUARE FLANGE

BORE	ROD øMM	KK SM	A	B	V	W	Y	ADD LB	STROKE P
1 1/2	5/8	7/16-20	3/4	1.125	1/4	5/8	1 15/16	4	2 1/4
1 1/2	1	3/4-16	1 1/8	1.5	1/2	1	2 5/16	4	2 1/4
2	5/8	7/16-20	3/4	1.125	1/4	5/8	1 15/16	4	2 1/4
2	1	3/4-16	1 1/8	1.5	1/2	1	2 5/16	4	2 1/4
2	1 3/8	1-14	1 5/8	2	5/8	1 1/4	2 9/16	4	2 1/4
2 1/2	5/8	7/16-20	3/4	1.125	1/4	5/8	1 15/16	4 1/8	2 3/8
2 1/2	1	3/4-16	1 1/8	1.5	1/2	1	2 5/16	4 1/8	2 3/8
2 1/2	1 3/8	1-14	1 5/8	2	5/8	1 1/4	2 9/16	4 1/8	2 3/8
3 1/4	1	3/4-16	1 1/8	1.5	1/4	3/4	2 3/8	4 7/8	2 5/8
3 1/4	1 3/8	1-14	1 5/8	2	3/8	1	2 5/8	4 7/8	2 5/8
4	1	3/4-16	1 1/8	1.5	1/4	3/4	2 3/8	4 7/8	2 5/8
4	1 3/8	1-14	1 5/8	2	3/8	1	2 5/8	4 7/8	2 5/8
5	1	3/4-16	1 1/8	1.5	1/4	3/4	2 5/16	5 1/8	2 7/8
5	1 3/8	1-14	1 5/8	2	3/8	1	2 9/16	5 1/8	2 7/8
5	1 3/4	1 1/4-12	2	2.375	1/2	1 1/4	2 13/16	5 1/8	2 7/8
6	1 3/8	1-14	1 5/8	2	1/4	7/8	2 13/16	5 3/4	3 1/8
6	1 3/4	1 1/4-12	2	2.375	3/8	1 1/8	3 1/16	5 3/4	3 1/8
6	2	1 1/2-12	2 1/4	2.625	3/8	1 1/4	3 3/16	5 3/4	3 1/8

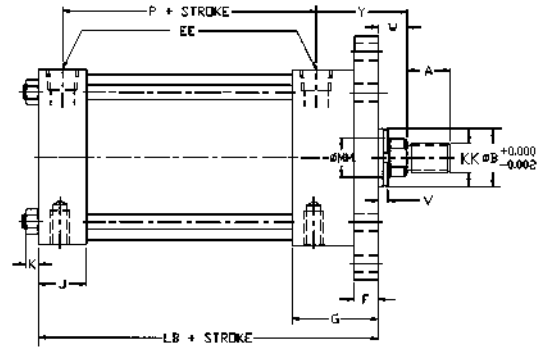

BORE	E	EE(NPT)	F	FB	G	J	K	R	TF	UF
1 1/2	2	3/8	3/8	5/16	2	1	1/4	1.43	2 3/4	3 3/8
2	2 1/2	3/8	3/8	3/8	2	1	5/16	1.84	3 3/8	4 1/8
2 1/2	3	3/8	3/8	3/8	2	1 1/8	5/16	2.19	3 7/8	4 5/8
3 1/4	3 3/4	1/2	5/8	7/16	2 1/4	1 1/4	3/8	2.76	4 11/16	5 1/2
4	4 1/2	1/2	5/8	7/16	2 1/4	1 1/4	3/8	3.32	5 7/16	6 1/4
5	5 1/2	1/2	5/8	9/16	2 1/4	1 1/2	7/16	4.10	6 5/8	7 5/8
6	6 1/2	3/4	3/4	9/16	2 3/4	1 5/8	7/16	4.88	7 5/8	8 5/8

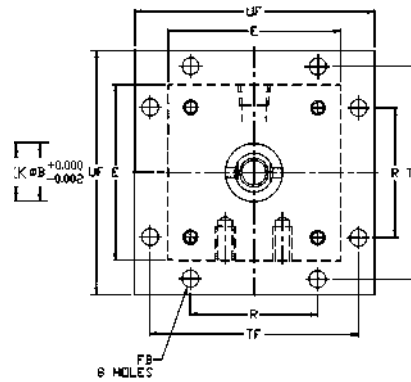

MF6 $\varnothing 1.5'' \sim 6''$
WITH REAR SQUARE FLANGE

BORE	ROD øMM	KK SM	A	B	V	W	Y	ADD LB	STROKE P
1 1/2	5/8	7/16-20	3/4	1.125	1/4	5/8	1 15/16	4	2 1/4
1 1/2	1	3/4-16	1 1/8	1.5	1/2	1	2 5/16	4	2 1/4
2	5/8	7/16-20	3/4	1.125	1/4	5/8	1 15/16	4	2 1/4
2	1	3/4-16	1 1/8	1.5	1/2	1	2 5/16	4	2 1/4
2	1 3/8	1-14	1 5/8	2	5/8	1 1/4	2 9/16	4	2 1/4
2 1/2	5/8	7/16-20	3/4	1.125	1/4	5/8	1 15/16	4 1/8	2 3/8
2 1/2	1	3/4-16	1 1/8	1.5	1/2	1	2 5/16	4 1/8	2 3/8
2 1/2	1 3/8	1-14	1 5/8	2	5/8	1 1/4	2 9/16	4 1/8	2 3/8
3 1/4	1	3/4-16	1 1/8	1.5	1/4	3/4	2 3/8	4 7/8	2 5/8
3 1/4	1 3/8	1-14	1 5/8	2	3/8	1	2 5/8	4 7/8	2 5/8
4	1	3/4-16	1 1/8	1.5	1/4	3/4	2 3/8	4 7/8	2 5/8
4	1 3/8	1-14	1 5/8	2	3/8	1	2 5/8	4 7/8	2 5/8
5	1	3/4-16	1 1/8	1.5	1/4	3/4	2 5/16	5 1/8	2 7/8
5	1 3/8	1-14	1 5/8	2	3/8	1	2 9/16	5 1/8	2 7/8
5	1 3/4	1 1/4-12	2	2.375	1/2	1 1/4	2 13/16	5 1/8	2 7/8
6	1 3/8	1-14	1 5/8	2	1/4	7/8	2 13/16	5 3/4	3 1/8
6	1 3/4	1 1/4-12	2	2.375	3/8	1 1/8	3 1/16	5 3/4	3 1/8
6	2	1 1/2-12	2 1/4	2.625	3/8	1 1/4	3 3/16	5 3/4	3 1/8

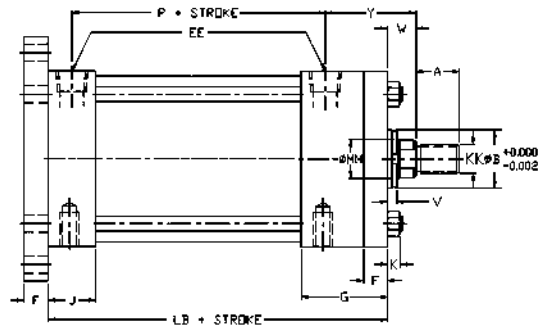

BORE	E	EE(NPT)	F	FB	G	J	K	R	TF	UF
1 1/2	2	3/8	3/8	5/16	2	1	1/4	1.43	2 3/4	3 3/8
2	2 1/2	3/8	3/8	3/8	2	1	5/16	1.84	3 3/8	4 1/8
2 1/2	3	3/8	3/8	3/8	2	1 1/8	5/16	2.19	3 7/8	4 5/8
3 1/4	3 3/4	1/2	5/8	7/16	2 1/4	1 1/4	3/8	2.76	4 11/16	5 1/2
4	4 1/2	1/2	5/8	7/16	2 1/4	1 1/4	3/8	3.32	5 7/16	6 1/4
5	5 1/2	1/2	5/8	9/16	2 1/4	1 1/2	7/16	4.10	6 5/8	7 5/8
6	6 1/2	3/4	3/4	9/16	2 3/4	1 5/8	7/16	4.88	7 5/8	8 5/8

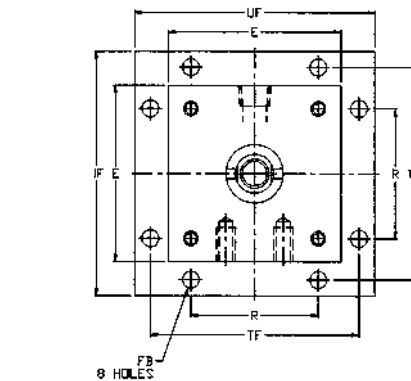

MP1 $\varnothing 1.5" \sim 6"$
WITH DOUBLE REAR CLEVIS

BORE	Rod \varnothing MM	KK SM	A	B	V	W	Y	ADD STROKE		
								LB	P	XC
1 1/2	5/8	7/16-20	3/4	1.125	1/4	5/8	1 15/16	4	2 1/4	5 3/8
1 1/2	1	3/4-16	1 1/8	1.5	1/2	1	2 5/16	4	2 1/4	5 3/4
2	5/8	7/16-20	3/4	1.125	1/4	5/8	1 15/16	4	2 1/4	5 3/8
2	1	3/4-16	1 1/8	1.5	1/2	1	2 5/16	4	2 1/4	5 3/4
2	1 3/8	1-14	1 5/8	2	5/8	1 1/4	2 9/16	4	2 1/4	6
2 1/2	5/8	7/16-20	3/4	1.125	1/4	5/8	1 15/16	4 1/8	2 3/8	5 1/2
2 1/2	1	3/4-16	1 1/8	1.5	1/2	1	2 5/16	4 1/8	2 3/8	5 7/8
2 1/2	1 3/8	1-14	1 5/8	2	5/8	1 1/4	2 9/16	4 1/8	2 3/8	6 1/8
3 1/4	1	3/4-16	1 1/8	1.5	1/4	3/4	2 3/8	4 7/8	2 5/8	6 7/8
3 1/4	1 3/8	1-14	1 5/8	2	3/8	1	2 5/8	4 7/8	2 5/8	7 1/8
4	1	3/4-16	1 1/8	1.5	1/4	3/4	2 3/8	4 7/8	2 5/8	6 7/8
4	1 3/8	1-14	1 5/8	2	3/8	1	2 5/8	4 7/8	2 5/8	7 1/8
5	1	3/4-16	1 1/8	1.5	1/4	3/4	2 5/16	5 1/8	2 7/8	7 1/8
5	1 3/8	1-14	1 5/8	2	3/8	1	2 9/16	5 1/8	2 7/8	7 3/8
5	1 3/4	1 1/4-12	2	2.375	1/2	1 1/4	2 13/16	5 1/8	2 7/8	7 5/8
6	1 3/8	1-14	1 5/8	2	1/4	7/8	2 13/16	5 3/4	3 1/8	8 1/8
6	1 3/4	1 1/4-12	2	2.375	3/8	1 1/8	3 1/16	5 3/4	3 1/8	8 3/8
6	2	1 1/2-12	2 1/4	2.625	3/8	1 1/4	3 3/16	5 3/4	3 1/8	8 1/2

BORE	CB	CD	CW	E	EE(NPT)	F
1 1/2	3/4	1/2	1/2	2	3/8	3/8
2	3/4	1/2	1/2	2 1/2	3/8	3/8
2 1/2	3/4	1/2	1/2	3	3/8	3/8
3 1/4	1 1/4	3/4	5/8	3 3/4	1/2	5/8
4	1 1/4	3/4	5/8	4 1/2	1/2	5/8
5	1 1/4	3/4	5/8	5 1/2	1/2	5/8
6	1 1/2	1	3/4	6 1/2	3/4	3/4

BORE	G	J	K	L	LR	MR
1 1/2	2	1	1/4	3/4	3/4	5/8
2	2	1	5/16	3/4	3/4	5/8
2 1/2	2	1 1/8	5/16	3/4	3/4	5/8
3 1/4	2 1/4	1 1/4	3/8	1 1/4	1 1/4	7/8
4	2 1/4	1 1/4	3/8	1 1/4	1 1/4	7/8
5	2 1/4	1 1/2	7/16	1 1/4	1 1/4	7/8
6	2 3/4	1 5/8	7/16	1 1/2	1 1/2	1 1/4

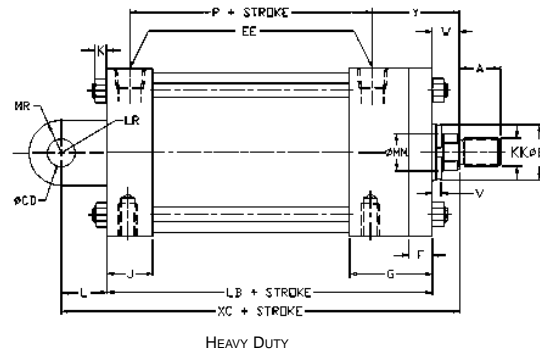

HEAVY DUTY

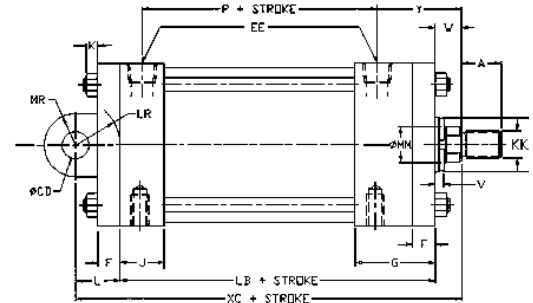
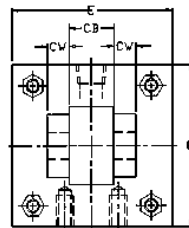

MEDIUM DUTY

MP2 $\varnothing 1.5" \sim 6"$
WITH DOUBLE DETACHABLE REAR CLEVIS / FEMALE

BORE	Rod \varnothing MM	KK SM	A	B	V	W	Y	ADD STROKE		
								LB	P	XD
1 1/2	5/8	7/16-20	3/4	1.125	1/4	5/8	1 15/16	4	2 1/4	5 3/4
1 1/2	1	3/4-16	1 1/8	1.5	1/2	1	2 5/16	4	2 1/4	6 1/8
2	5/8	7/16-20	3/4	1.125	1/4	5/8	1 15/16	4	2 1/4	5 3/4
2	1	3/4-16	1 1/8	1.5	1/2	1	2 5/16	4	2 1/4	6 1/8
2	1 3/8	1-14	1 5/8	2	5/8	1 1/4	2 9/16	4	2 1/4	6 3/8
2 1/2	5/8	7/16-20	3/4	1.125	1/4	5/8	1 15/16	4 1/8	2 3/8	5 7/8
2 1/2	1	3/4-16	1 1/8	1.5	1/2	1	2 5/16	4 1/8	2 3/8	6 1/4
2 1/2	1 3/8	1-14	1 5/8	2	5/8	1 1/4	2 9/16	4 1/8	2 3/8	6 1/2
3 1/4	1	3/4-16	1 1/8	1.5	1/4	3/4	2 3/8	4 7/8	2 5/8	7 1/2
3 1/4	1 3/8	1-14	1 5/8	2	3/8	1	2 5/8	4 7/8	2 5/8	7 3/4
4	1	3/4-16	1 1/8	1.5	1/4	3/4	2 3/8	4 7/8	2 5/8	7 1/2
4	1 3/8	1-14	1 5/8	2	3/8	1	2 5/8	4 7/8	2 5/8	7 3/4
5	1	3/4-16	1 1/8	1.5	1/4	3/4	2 5/16	5 1/8	2 7/8	7 3/4
5	1 3/8	1-14	1 5/8	2	3/8	1	2 9/16	5 1/8	2 7/8	8
5	1 3/4	1 1/4-12	2	2.375	1/2	1 1/4	2 13/16	5 1/8	2 7/8	8 1/4
6	1 3/8	1-14	1 5/8	2	1/4	7/8	2 13/16	5 3/4	3 1/8	8 7/8
6	1 3/4	1 1/4-12	2	2.375	3/8	1 1/8	3 1/16	5 3/4	3 1/8	9 1/8
6	2	1 1/2-12	2 1/4	2.625	3/8	1 1/4	3 3/16	5 3/4	3 1/8	9 1/4

BORE	CB	CD	CW	E	EE(NPT)	F
1 1/2	3/4	1/2	1/2	2	3/8	3/8
2	3/4	1/2	1/2	2 1/2	3/8	3/8
2 1/2	3/4	1/2	1/2	3	3/8	3/8
3 1/4	1 1/4	3/4	5/8	3 3/4	1/2	5/8
4	1 1/4	3/4	5/8	4 1/2	1/2	5/8
5	1 1/4	3/4	5/8	5 1/2	1/2	5/8
6	1 1/2	1	3/4	6 1/2	3/4	3/4

BORE	G	J	K	L	LR	MR
1 1/2	3/8	2	1 1/4	3/4	3/4	5/8
2	2	1	5/16	3/4	3/4	5/8
2 1/2	2	1 1/8	5/16	3/4	3/4	5/8
3 1/4	2 1/4	1 1/4	3/8	1 1/4	1 1/4	7/8
4	2 1/4	1 1/4	3/8	1 1/4	1 1/4	7/8
5	2 1/4	1 1/2	7/16	1 1/4	1 1/4	7/8
6	2 3/4	1 5/8	7/16	1 1/2	1 1/2	1 1/4

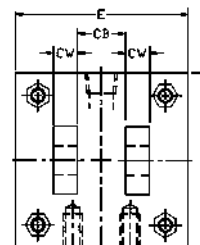
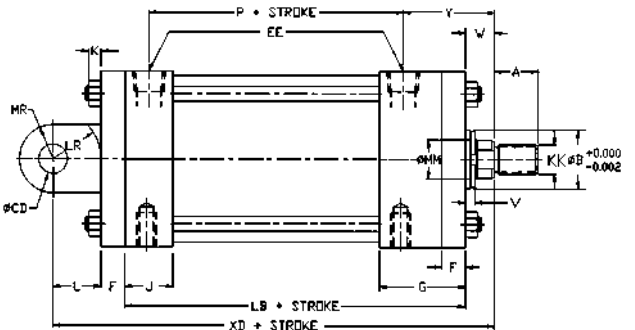

MP3 $\varnothing 1.5" \sim 6"$
WITH CAP FIXED EYE

BORE	Rod \varnothing MM	KK SM	A	B	V	W	Y	ADD STROKE		
								LB	P	XC
1 1/2	5/8	7/16-20	3/4	1.125	1/4	5/8	1 15/16	4	2 1/4	5 3/8
1 1/2	1	3/4-16	1 1/8	1.5	1/2	1	2 5/16	4	2 1/4	5 3/4
2	5/8	7/16-20	3/4	1.125	1/4	5/8	1 15/16	4	2 1/4	5 3/8
2	1	3/4-16	1 1/8	1.5	1/2	1	2 5/16	4	2 1/4	5 3/4
2	1 3/8	1-14	1 5/8	2	5/8	1 1/4	2 9/16	4	2 1/4	6
2 1/2	5/8	7/16-20	3/4	1.125	1/4	5/8	1 15/16	4 1/8	2 3/8	5 1/2
2 1/2	1	3/4-16	1 1/8	1.5	1/2	1	2 5/16	4 1/8	2 3/8	5 7/8
2 1/2	1 3/8	1-14	1 5/8	2	5/8	1 1/4	2 9/16	4 1/8	2 3/8	6 1/8
3 1/4	1	3/4-16	1 1/8	1.5	1/4	3/4	2 3/8	4 7/8	2 5/8	6 7/8
3 1/4	1 3/8	1-14	1 5/8	2	3/8	1	2 5/8	4 7/8	2 5/8	7 1/8
4	1	3/4-16	1 1/8	1.5	1/4	3/4	2 3/8	4 7/8	2 5/8	6 7/8
4	1 3/8	1-14	1 5/8	2	3/8	1	2 5/8	4 7/8	2 5/8	7 1/8
5	1	3/4-16	1 1/8	1.5	1/4	3/4	2 5/16	5 1/8	2 7/8	7 1/8
5	1 3/8	1-14	1 5/8	2	3/8	1	2 9/16	5 1/8	2 7/8	7 3/8
5	1 3/4	1 1/4-12	2	2.375	1/2	1 1/4	2 13/16	5 1/8	2 7/8	7 5/8
6	1 3/8	1-14	1 5/8	2	1/4	7/8	2 13/16	5 3/4	3 1/8	8 1/8
6	1 3/4	1 1/4-12	2	2.375	3/8	1 1/8	3 1/16	5 3/4	3 1/8	8 3/8
6	2	1 1/2-12	2 1/4	2.625	3/8	1 1/4	3 3/16	5 3/4	3 1/8	8 1/2

BORE	CB	CD	E	EE(NPT)	F
1 1/2	3/4	1/2	2	3/8	3/8
2	3/4	1/2	2 1/2	3/8	3/8
2 1/2	3/4	1/2	3	3/8	3/8
3 1/4	1 1/4	3/4	3 3/4	1/2	5/8
4	1 1/4	3/4	4 1/2	1/2	5/8
5	1 1/4	3/4	5 1/2	1/2	5/8
6	1 1/2	1	6 1/2	3/4	3/4

BORE	G	J	K	L	LR	MR
1 1/2	2	1	1/4	3/4	3/4	5/8
2	2	1	5/16	3/4	3/4	5/8
2 1/2	2	1 1/8	5/16	3/4	3/4	5/8
3 1/4	2 1/4	1 1/4	3/8	1 1/4	1 1/4	7/8
4	2 1/4	1 1/4	3/8	1 1/4	1 1/4	7/8
5	2 1/4	1 1/2	7/16	1 1/4	1 1/4	7/8
6	2 3/4	1 5/8	7/16	1 1/2	1 1/2	1 1/4

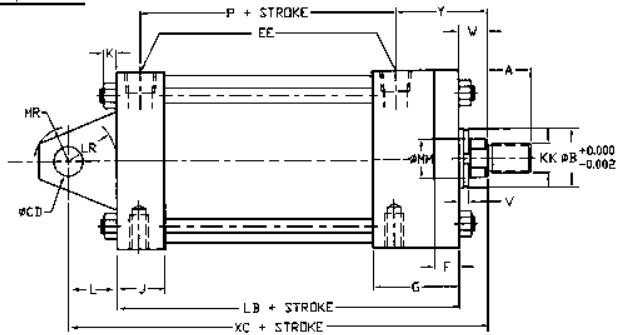
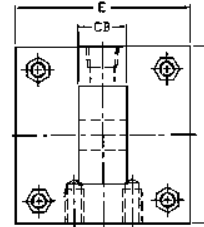

MP4 $\varnothing 1.5" \sim 6"$
WITH SINGLE DETACHABLE REAR CLEVIS / MALE

BORE	Rod \varnothing MM	KK SM	A	B	V	W	Y	ADD STROKE		
								LB	P	XD
1 1/2	5/8	7/16-20	3/4	1.125	1/4	5/8	1 15/16	4	2 1/4	5 3/4
1 1/2	1	3/4-16	1 1/8	1.5	1/2	1	2 5/16	4	2 1/4	6 1/8
2	5/8	7/16-20	3/4	1.125	1/4	5/8	1 15/16	4	2 1/4	5 3/4
2	1	3/4-16	1 1/8	1.5	1/2	1	2 5/16	4	2 1/4	6 1/8
2	1 3/8	1-14	1 5/8	2	5/8	1 1/4	2 9/16	4	2 1/4	6 3/8
2 1/2	5/8	7/16-20	3/4	1.125	1/4	5/8	1 15/16	4 1/8	2 3/8	5 7/8
2 1/2	1	3/4-16	1 1/8	1.5	1/2	1	2 5/16	4 1/8	2 3/8	6 1/4
2 1/2	1 3/8	1-14	1 5/8	2	5/8	1 1/4	2 9/16	4 1/8	2 3/8	6 1/2
3 1/4	1	3/4-16	1 1/8	1.5	1/4	3/4	2 3/8	4 7/8	2 5/8	7 1/2
3 1/4	1 3/8	1-14	1 5/8	2	3/8	1	2 5/8	4 7/8	2 5/8	7 3/4
4	1	3/4-16	1 1/8	1.5	1/4	3/4	2 3/8	4 7/8	2 5/8	7 1/2
4	1 3/8	1-14	1 5/8	2	3/8	1	2 5/8	4 7/8	2 5/8	7 3/4
5	1	3/4-16	1 1/8	1.5	1/4	3/4	2 5/16	5 1/8	2 7/8	7 3/4
5	1 3/8	1-14	1 5/8	2	3/8	1	2 9/16	5 1/8	2 7/8	8
5	1 3/4	1 1/4-12	2	2.375	1/2	1 1/4	2 13/16	5 1/8	2 7/8	8 1/4
6	1 3/8	1-14	1 5/8	2	1/4	7/8	2 13/16	5 3/4	3 1/8	8 7/8
6	1 3/4	1 1/4-12	2	2.375	3/8	1 1/8	3 1/16	5 3/4	3 1/8	9 1/8
6	2	1 1/2-12	2 1/4	2.625	3/8	1 1/4	3 3/16	5 3/4	3 1/8	9 1/4

BORE	CB	CD	E	EE(NPT)	F
1 1/2	3/4	1/2	2	3/8	3/8
2	3/4	1/2	2 1/2	3/8	3/8
2 1/2	3/4	1/2	3	3/8	3/8
3 1/4	1 1/4	3/4	3 3/4	1/2	5/8
4	1 1/4	3/4	4 1/2	1/2	5/8
5	1 1/4	3/4	5 1/2	1/2	5/8
6	1 1/2	1	6 1/2	3/4	3/4

BORE	G	J	K	L	LR	MR
1 1/2	2	1	1/4	3/4	3/4	5/8
2	2	1	5/16	3/4	3/4	5/8
2 1/2	2	1 1/8	5/16	3/4	3/4	5/8
3 1/4	2 1/4	1 1/4	3/8	1 1/4	1 1/4	7/8
4	2 1/4	1 1/4	3/8	1 1/4	1 1/4	7/8
5	2 1/4	1 1/2	7/16	1 1/4	1 1/4	7/8
6	2 3/4	1 5/8	7/16	1 1/2	1 1/2	1 1/4

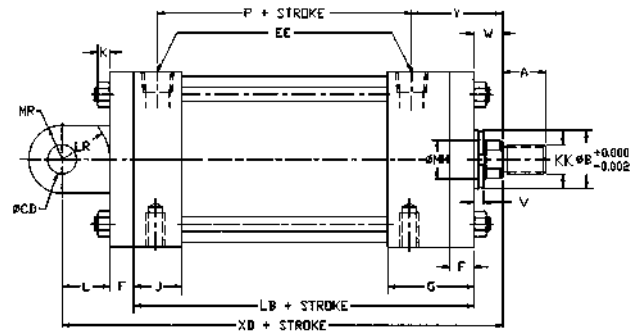
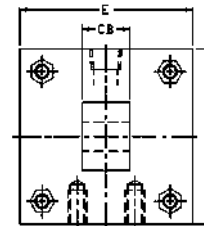

MS1 $\varnothing 1.5'' \sim 6''$
WITH FOOT MOUNT

BORE	Rod \varnothing MM	KK SM	A	B	V	W	Y	ADD STROKE		
								LB	P	SA
1 1/2	5/8	7/16-20	3/4	1.125	1/4	5/8	1 15/16	4	2 1/4	6
1 1/2	1	3/4-16	1 1/8	1.5	1/2	1	2 5/16	4	2 1/4	6
2	5/8	7/16-20	3/4	1.125	1/4	5/8	1 15/16	4	2 1/4	6
2	1	3/4-16	1 1/8	1.5	1/2	1	2 5/16	4	2 1/4	6
2	1 3/8	1-14	1 5/8	2	5/8	1 1/4	2 9/16	4	2 1/4	6
2 1/2	5/8	7/16-20	3/4	1.125	1/4	5/8	1 15/16	4 1/8	2 3/8	6 1/8
2 1/2	1	3/4-16	1 1/8	1.5	1/2	1	2 5/16	4 1/8	2 3/8	6 1/8
2 1/2	1 3/8	1-14	1 5/8	2	5/8	1 1/4	2 9/16	4 1/8	2 3/8	6 1/8
3 1/4	1	3/4-16	1 1/8	1.5	1/4	3/4	2 3/8	4 7/8	2 5/8	7 3/8
3 1/4	1 3/8	1-14	1 5/8	2	3/8	1	2 5/8	4 7/8	2 5/8	7 3/8
4	1	3/4-16	1 1/8	1.5	1/4	3/4	2 3/8	4 7/8	2 5/8	7 3/8
4	1 3/8	1-14	1 5/8	2	3/8	1	2 5/8	4 7/8	2 5/8	7 3/8
5	1	3/4-16	1 1/8	1.5	1/4	3/4	2 5/16	5 1/8	2 7/8	7 7/8
5	1 3/8	1-14	1 5/8	2	3/8	1	2 9/16	5 1/8	2 7/8	7 7/8
5	1 3/4	1 1/4-12	2	2.375	1/2	1 1/4	2 13/16	5 1/8	2 7/8	7 7/8
6	1 3/8	1-14	1 5/8	2	1/4	7/8	2 13/16	5 3/4	3 1/8	8 1/2
6	1 3/4	1 1/4-12	2	2.375	3/8	1 1/8	3 1/16	5 3/4	3 1/8	8 1/2
6	2	1 1/2-12	2 1/4	2.625	3/8	1 1/4	3 3/16	5 3/4	3 1/8	8 1/2

BORE	AB	AH	AL	AO	AT
1 1/2	7/16	1 3/16	1	3/8	1/8
2	7/16	1 7/16	1	3/8	1/8
2 1/2	7/16	1 5/8	1	3/8	1/8
3 1/4	9/16	1 15/16	1 1/4	1/2	1/8
4	9/16	2 1/4	1 1/4	1/2	1/8
5	11/16	2 3/4	1 3/8	5/8	3/16
6	13/16	3 1/4	1 3/8	5/8	3/16

BORE	E	EE(NPT)	F	G	J	K	S
1 1/2	2	3/8	3/8	2	1	1/4	1 1/4
2	2 1/2	3/8	3/8	2	1	5/16	1 3/4
2 1/2	3	3/8	3/8	2	1 1/8	5/16	2 1/4
3 1/4	3 3/4	1/2	5/8	2 1/4	1 1/4	5/16	2 3/4
4	4 1/2	1/2	5/8	2 1/4	1 1/4	3/8	3 1/2
5	5 1/2	1/2	5/8	2 1/4	1 1/2	7/16	4 1/4
6	6 1/2	3/4	3/4	2 3/4	1 5/8	7/16	5 1/4

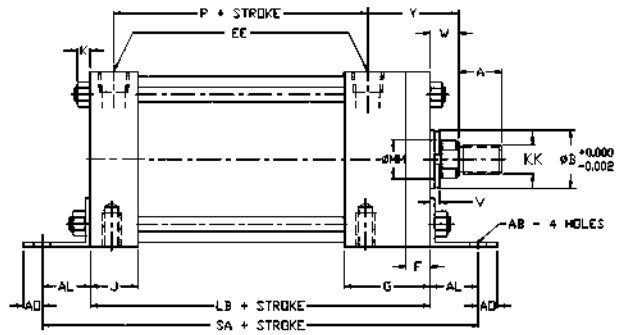
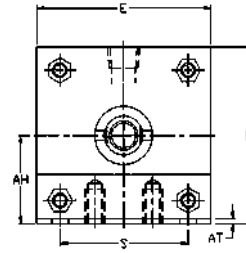

MS2 $\varnothing 1.5'' \sim 6''$
WITH SIDE LUG

BORE	Rod \varnothing MM	KK SM	A	B	V	W	XS	Y	ADD STROKE		
									LB	P	SS
1 1/2	5/8	7/16-20	3/4	1.125	1/4	5/8	1 3/8	1 15/16	4	2 1/4	2 7/8
1 1/2	1	3/4-16	1 1/8	1.5	1/2	1	1 3/4	2 5/16	4	2 1/4	2 7/8
2	5/8	7/16-20	3/4	1.125	1/4	5/8	1 15/16	1 15/16	4	2 1/4	2 7/8
2	1	3/4-16	1 1/8	1.5	1/2	1	2 5/16	2 5/16	4	2 1/4	2 7/8
2	1 3/8	1-14	1 5/8	2	5/8	1 1/4	2	2 9/16	4	2 1/4	2 7/8
2 1/2	5/8	7/16-20	3/4	1.125	1/4	5/8	1 3/8	1 15/16	4 1/8	2 3/8	3
2 1/2	1	3/4-16	1 1/8	1.5	1/2	1	1 3/4	2 5/16	4 1/8	2 3/8	3
2 1/2	1 3/8	1-14	1 5/8	2	5/8	1 1/4	2	2 9/16	4 1/8	2 3/8	3
3 1/4	1	3/4-16	1 1/8	1.5	1/4	3/4	1 7/8	2 3/8	4 7/8	2 5/8	3 1/4
3 1/4	1 3/8	1-14	1 5/8	2	3/8	1	2 1/8	2 5/8	4 7/8	2 5/8	3 1/4
4	1	3/4-16	1 1/8	1.5	1/4	3/4	1 7/8	2 3/8	4 7/8	2 5/8	3 1/4
4	1 3/8	1-14	1 5/8	2	3/8	1	2 1/8	2 5/8	4 7/8	2 5/8	3 1/4
5	1	3/4-16	1 1/8	1.5	1/4	3/4	2 1/16	2 5/16	5 1/8	2 7/8	3 1/8
5	1 3/8	1-14	1 5/8	2	3/8	1	2 5/16	2 9/16	5 1/8	2 7/8	3 1/8
5	1 3/4	1 1/4-12	2	2.375	1/2	1 1/4	2 9/16	2 13/16	5 1/8	2 7/8	3 1/8
6	1 3/8	1-14	1 5/8	2	1/4	7/8	2 5/16	2 13/16	5 3/4	3 1/8	3 5/8
6	1 3/4	1 1/4-12	2	2.375	3/8	1 1/8	2 9/16	3 1/16	5 3/4	3 1/8	3 5/8
6	2	1 1/2-12	2 1/4	2.625	3/8	1 1/4	2 11/16	3 3/16	5 3/4	3 1/8	3 5/8

BORE	E	EE(NPT)	F	G	J	K
1 1/2	2	3/8	3/8	2	1	1/4
2	2 1/2	3/8	3/8	2	1	5/16
2 1/2	3	3/8	3/8	2	1 1/8	5/16
3 1/4	3 3/4	1/2	5/8	2 1/4	1 1/4	3/8
4	4 1/2	1/2	5/8	2 1/4	1 1/4	3/8
5	5 1/2	1/2	5/8	2 1/4	1 1/2	7/16
6	6 1/2	3/4	3/4	2 3/4	1 5/8	7/16

BORE	SB	ST	SU	SW	TS
1 1/2	7/16	1/2	15/16	3/8	2 3/4
2	7/16	1/2	15/16	3/8	3 1/4
2 1/2	7/16	1/2	15/16	3/8	3 3/4
3 1/4	9/16	3/4	1 1/4	1/2	4 3/4
4	9/16	3/4	1 1/4	1/2	5 1/2
5	13/16	1	1 9/16	11/16	6 7/8
6	13/16	1	1 9/16	11/16	7 7/8

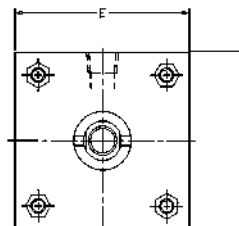
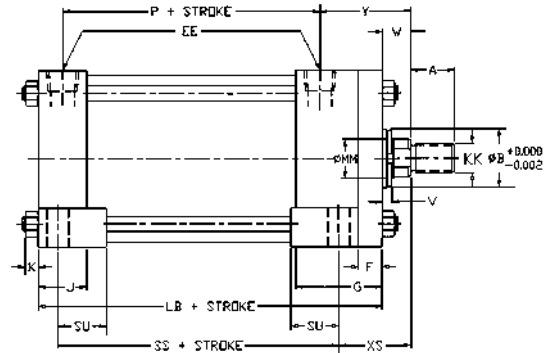

MS3 $\phi 1.5" \sim 6"$
WITH CENTERLINE LUG

BORE	ROD ϕ MM	KK SM	A	B	V	W	XS	Y	ADD STROKE		
									LB	P	SS
1 1/2	5/8	7/16-20	3/4	1.125	1/4	5/8	1 3/8	1 15/16	4	2 1/4	2 7/8
1 1/2	1	3/4-16	1 1/8	1.5	1/2	1	1 3/4	2 5/16	4	2 1/4	2 7/8
2	5/8	7/16-20	3/4	1.125	1/4	5/8	1 15/16	1 15/16	4	2 1/4	2 7/8
2	1	3/4-16	1 1/8	1.5	1/2	1	2 5/16	2 5/16	4	2 1/4	2 7/8
2	1 3/8	1-14	1 5/8	2	5/8	1 1/4	2	2 9/16	4	2 1/4	2 7/8
2 1/2	5/8	7/16-20	3/4	1.125	1/4	5/8	1 3/8	1 15/16	4 1/8	2 3/8	3
2 1/2	1	3/4-16	1 1/8	1.5	1/2	1	1 3/4	2 5/16	4 1/8	2 3/8	3
2 1/2	1 3/8	1-14	1 5/8	2	5/8	1 1/4	2	2 9/16	4 1/8	2 3/8	3
3 1/4	1	3/4-16	1 1/8	1.5	1/4	3/4	1 7/8	2 3/8	4 7/8	2 5/8	3 1/4
3 1/4	1 3/8	1-14	1 5/8	2	3/8	1	2 1/8	2 5/8	4 7/8	2 5/8	3 1/4
4	1	3/4-16	1 1/8	1.5	1/4	3/4	1 7/8	2 3/8	4 7/8	2 5/8	3 1/4
4	1 3/8	1-14	1 5/8	2	3/8	1	2 1/8	2 5/8	4 7/8	2 5/8	3 1/4
5	1	3/4-16	1 1/8	1.5	1/4	3/4	2 1/16	2 5/16	5 1/8	2 7/8	3 1/8
5	1 3/8	1-14	1 5/8	2	3/8	1	2 5/16	2 9/16	5 1/8	2 7/8	3 1/8
5	1 3/4	1 1/4-12	2	2.375	1/2	1 1/4	2 9/16	2 13/16	5 1/8	2 7/8	3 1/8
6	1 3/8	1-14	1 5/8	2	1/4	7/8	2 5/16	2 13/16	5 3/4	3 1/8	3 5/8
6	1 3/4	1 1/4-12	2	2.375	3/8	1 1/8	2 9/16	3 1/16	5 3/4	3 1/8	3 5/8
6	2	1 1/2-12	2 1/4	2.625	3/8	1 1/4	2 11/16	3 3/16	5 3/4	3 1/8	3 5/8

BORE	E	EE(NPT)	F	G	J	K
1 1/2	2	3/8	3/8	2	1	1/4
2	2 1/2	3/8	3/8	2	1	5/16
2 1/2	3	3/8	3/8	2	1 1/8	5/16
3 1/4	3 3/4	1/2	5/8	2 1/4	1 1/4	3/8
4	4 1/2	1/2	5/8	2 1/4	1 1/4	3/8
5	5 1/2	1/2	5/8	2 1/4	1 1/2	7/16
6	6 1/2	3/4	3/4	2 3/4	1 5/8	7/16

BORE	SB	ST	SU	SW	TS
1 1/2	7/16	1/2	15/16	3/8	2 3/4
2	7/16	1/2	15/16	3/8	3 1/4
2 1/2	7/16	1/2	15/16	3/8	3 3/4
3 1/4	9/16	3/4	1 1/4	1/2	4 3/4
4	9/16	3/4	1 1/4	1/2	5 1/2
5	13/16	1	1 9/16	11/16	6 7/8
6	13/16	1	1 9/16	11/16	7 7/8

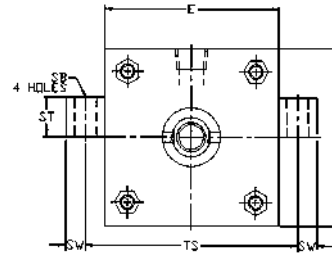
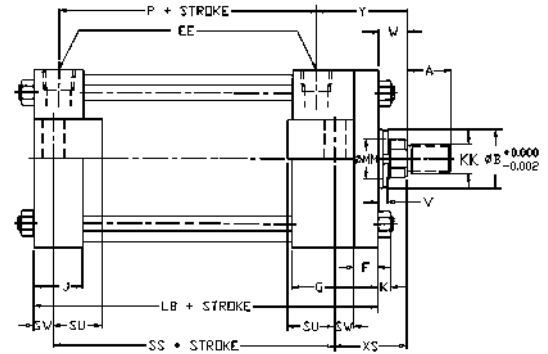

MS4 $\phi 1.5" \sim 6"$
SIDE TAPPED

BORE	ROD ϕ MM	KK SM	A	B	V	W	Y	ADD STROKE			
								LB	P	SN	XT
1 1/2	5/8	7/16-20	3/4	1.125	1/4	5/8	1 15/16	4	2 1/4	2 1/4	1 15/16
1 1/2	1	3/4-16	1 1/8	1.5	1/2	1	2 5/16	4	2 1/4	2 1/4	2 5/16
2	5/8	7/16-20	3/4	1.125	1/4	5/8	1 15/16	4	2 1/4	2 1/4	1 15/16
2	1	3/4-16	1 1/8	1.5	1/2	1	2 5/16	4	2 1/4	2 1/4	2 5/16
2	1 3/8	1-14	1 5/8	2	5/8	1 1/4	2 9/16	4	2 1/4	2 1/4	2 9/16
2 1/2	5/8	7/16-20	3/4	1.125	1/4	5/8	1 15/16	4 1/8	2 3/8	2 3/8	1 15/16
2 1/2	1	3/4-16	1 1/8	1.5	1/2	1	2 5/16	4 1/8	2 3/8	2 3/8	2 5/16
2 1/2	1 3/8	1-14	1 5/8	2	5/8	1 1/4	2 9/16	4 1/8	2 3/8	2 3/8	2 9/16
3 1/4	1	3/4-16	1 1/8	1.5	1/4	3/4	2 3/8	4 7/8	2 5/8	2 5/8	2 7/16
3 1/4	1 3/8	1-14	1 5/8	2	3/8	1	2 5/8	4 7/8	2 5/8	2 5/8	2 11/16
4	1	3/4-16	1 1/8	1.5	1/4	3/4	2 3/8	4 7/8	2 5/8	2 5/8	2 7/16
4	1 3/8	1-14	1 5/8	2	3/8	1	2 5/8	4 7/8	2 5/8	2 5/8	2 11/16
5	1	3/4-16	1 1/8	1.5	1/4	3/4	2 5/16	5 1/8	2 7/8	2 7/8	2 7/16
5	1 3/8	1-14	1 5/8	2	3/8	1	2 9/16	5 1/8	2 7/8	2 7/8	2 11/16
5	1 3/4	1 1/4-12	2	2.375	1/2	1 1/4	2 13/16	5 1/8	2 7/8	2 7/8	2 15/16
6	1 3/8	1-14	1 5/8	2	1/4	7/8	2 13/16	5 3/4	3 1/8	3 1/8	2 13/16
6	1 3/4	1 1/4-12	2	2.375	3/8	1 1/8	3 1/16	5 3/4	3 1/8	3 1/8	3 1/16
6	2	1 1/2-12	2 1/4	2.625	3/8	1 1/4	3 3/16	5 3/4	3 1/8	3 1/8	3 3/16

BORE	E	EE(NPT)	F	G	J	K	NT	TN
1 1/2	2	3/8	3/8	2	1	1/4	1/4-20	5/8
2	2 1/2	3/8	3/8	2	1	5/16	5/16-18	7/8
2 1/2	3	3/8	3/8	2	1 1/8	5/16	3/8-16	1 1/4
3 1/4	3 3/4	1/2	5/8	2 1/4	1 1/4	3/8	1/2-13	1 1/2
4	4 1/2	1/2	5/8	2 1/4	1 1/4	3/8	1/2-13	2 1/16
5	5 1/2	1/2	5/8	2 1/4	1 1/2	7/16	5/8-11	2 11/16
6	6 1/2	3/4	3/4	2 3/4	1 5/8	7/16	3/4-10	3 1/4

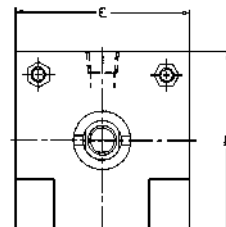
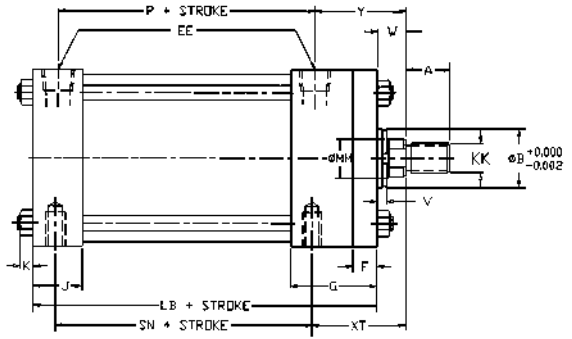

MS7 $\phi 1.5'' \sim 6''$
WITH FRONT LUG MOUNT

BORE	Rod ϕ MM	KK SM	A	B	V	W	Y	Add			STROKE
								LB	P	SE	
1 1/2	5/8	7/16-20	3/4	1.125	1/4	5/8	1 15/16	4	2 1/4	5 1/2	
1 1/2	1	3/4-16	1 1/8	1.5	1/2	1	2 5/16	4	2 1/4	5 1/2	
2	5/8	7/16-20	3/4	1.125	1/4	5/8	1 15/16	4	2 1/4	5 7/8	
2	1	3/4-16	1 1/8	1.5	1/2	1	2 5/16	4	2 1/4	5 7/8	
2	1 3/8	1-14	1 5/8	2	5/8	1 1/4	2 9/16	4	2 1/4	5 7/8	
2 1/2	5/8	7/16-20	3/4	1.125	1/4	5/8	1 15/16	4 1/8	2 3/8	6 1/4	
2 1/2	1	3/4-16	1 1/8	1.5	1/2	1	2 5/16	4 1/8	2 3/8	6 1/4	
2 1/2	1 3/8	1-14	1 5/8	2	5/8	1 1/4	2 9/16	4 1/8	2 3/8	6 1/4	
3 1/4	1	3/4-16	1 1/8	1.5	1/4	3/4	2 3/8	4 7/8	2 5/8	6 5/8	
3 1/4	1 3/8	1-14	1 5/8	2	3/8	1	2 5/8	4 7/8	2 5/8	6 5/8	
4	1	3/4-16	1 1/8	1.5	1/4	3/4	2 3/8	4 7/8	2 5/8	6 7/8	
4	1 3/8	1-14	1 5/8	2	3/8	1	2 5/8	4 7/8	2 5/8	6 7/8	
5	1	3/4-16	1 1/8	1.5	1/4	3/4	2 5/16	5 1/8	2 7/8	7 1/4	
5	1 3/8	1-14	1 5/8	2	3/8	1	2 9/16	5 1/8	2 7/8	7 1/4	
5	1 3/4	1 1/4-12	2	2.375	1/2	1 1/4	2 13/16	5 1/8	2 7/8	7 1/4	
6	1 3/8	1-14	1 5/8	2	1/4	7/8	2 13/16	5 3/4	3 1/8	7 3/4	
6	1 3/4	1 1/4-12	2	2.375	3/8	1 1/8	3 1/16	5 3/4	3 1/8	7 3/4	
6	2	1 1/2-12	2 1/4	2.625	3/8	1 1/4	3 3/16	5 3/4	3 1/8	7 3/4	

BORE	E	EB	EE(NPT)	EL	EO	ES	ET	F	G	J	K	R
1 1/2	2	5/16	3/8	3/4	1/4	9/16	17/32	3/8	2	1	1/4	1.43
2	2 1/2	3/8	3/8	15/16	5/16	5/8	5/8	3/8	2	1	5/16	1.84
2 1/2	3	3/8	3/8	1 1/16	5/16	13/16	25/32	3/8	2	1 1/8	5/16	2.19
3 1/4	3 3/4	7/16	1/2	7/8	3/8	1	15/16	5/8	2 1/4	1 1/4	3/8	2.76
4	4 1/2	7/16	1/2	1	3/8	1 1/4	1 5/32	5/8	2 1/4	1 1/4	3/8	3.32
5	5 1/2	9/16	1/2	1 1/16	1/2	1 3/8	1 3/8	5/8	2 1/4	1 1/2	7/16	4.1
6	6 1/2	9/16	3/4	1	1/2	1 3/4	1 19/32	3/4	2 3/4	1 5/8	7/16	4.88

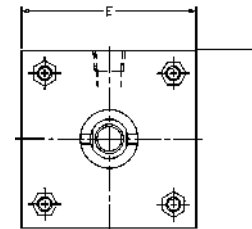
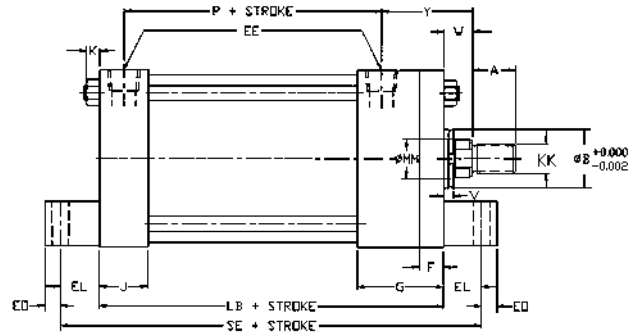

MT1 $\phi 1.5'' \sim 6''$
WITH HEAD TRUNNION

BORE	Rod ϕ MM	KK SM	A	B	V	W	XG	Y	Add		STROKE
									LB	P	
1 1/2	5/8	7/16-20	3/4	1.125	1/4	5/8	1 3/4	1 15/16	4	2 1/4	
1 1/2	1	3/4-16	1 1/8	1.5	1/2	1	2 1/8	2 5/16	4	2 1/4	
2	5/8	7/16-20	3/4	1.125	1/4	5/8	1 3/4	1 15/16	4	2 1/4	
2	1	3/4-16	1 1/8	1.5	1/2	1	2 1/8	2 5/16	4	2 1/4	
2	1 3/8	1-14	1 5/8	2	5/8	1 1/4	2 3/8	2 9/16	4	2 1/4	
2 1/2	5/8	7/16-20	3/4	1.125	1/4	5/8	1 3/4	1 15/16	4 1/8	2 3/8	
2 1/2	1	3/4-16	1 1/8	1.5	1/2	1	2 1/8	2 5/16	4 1/8	2 3/8	
2 1/2	1 3/8	1-14	1 5/8	2	5/8	1 1/4	2 3/8	2 9/16	4 1/8	2 3/8	
3 1/4	1	3/4-16	1 1/8	1.5	1/4	3/4	2 1/4	2 3/8	4 7/8	2 5/8	
3 1/4	1 3/8	1-14	1 5/8	2	3/8	1	2 1/2	2 5/8	4 7/8	2 5/8	
4	1	3/4-16	1 1/8	1.5	1/4	3/4	2 1/4	2 3/8	4 7/8	2 5/8	
4	1 3/8	1-14	1 5/8	2	3/8	1	2 1/2	2 5/8	4 7/8	2 5/8	
5	1	3/4-16	1 1/8	1.5	1/4	3/4	2 1/4	2 5/16	5 1/8	2 7/8	
5	1 3/8	1-14	1 5/8	2	3/8	1	2 1/2	2 9/16	5 1/8	2 7/8	
5	1 3/4	1 1/4-12	2	2.375	1/2	1 1/4	2 3/4	2 13/16	5 1/8	2 7/8	
6	1 3/8	1-14	1 5/8	2	1/4	7/8	2 5/8	2 13/16	5 3/4	3 1/8	
6	1 3/4	1 1/4-12	2	2.375	3/8	1 1/8	2 7/8	3 1/16	5 3/4	3 1/8	
6	2	1 1/2-12	2 1/4	2.625	3/8	1 1/4	3	3 3/16	5 3/4	3 1/8	

BORE	E	EE(NPT)	F	G	J	K	TD	TL	UT
1 1/2	2	3/8	3/8	2	1	1/4	1	1	4
2	2 1/2	3/8	3/8	2	1	5/16	1	1	4 1/2
2 1/2	3	3/8	3/8	2	1 1/8	5/16	1	1	5
3 1/4	3 3/4	1/2	5/8	2 1/4	1 1/4	3/8	1	1	5 3/4
4	4 1/2	1/2	5/8	2 1/4	1 1/4	3/8	1	1	6 1/2
5	5 1/2	1/2	5/8	2 1/4	1 1/2	7/16	1	1	7 1/2
6	6 1/2	3/4	3/4	2 3/4	1 5/8	7/16	1 3/8	1 3/8	9 1/4

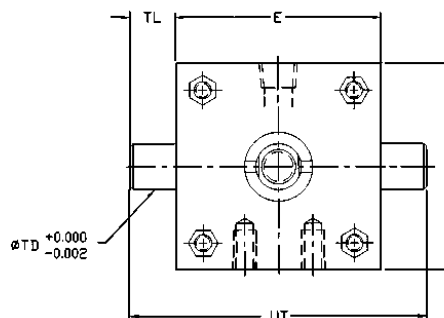
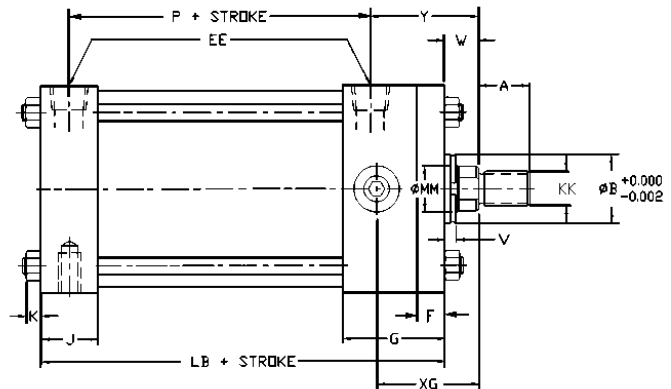

MT2 $\phi 1.5'' \sim 6''$
WITH REAR TRUNNION

BORE	ROD ϕ MM	KK SM	A	B	V	W	Y	ADD LB	STROKE P	XJ
1 1/2	5/8	7/16-20	3/4	1.125	1/4	5/8	1 15/16	4	2 1/4	4 1/8
1 1/2	1	3/4-16	1 1/8	1.5	1/2	1	2 5/16	4	2 1/4	4 1/2
2	5/8	7/16-20	3/4	1.125	1/4	5/8	1 15/16	4	2 1/4	4 1/8
2	1	3/4-16	1 1/8	1.5	1/2	1	2 5/16	4	2 1/4	4 1/2
2	1 3/8	1-14	1 5/8	2	5/8	1 1/4	2 9/16	4	2 1/4	4 3/4
2 1/2	5/8	7/16-20	3/4	1.125	1/4	5/8	1 15/16	4 1/8	2 3/8	4 1/4
2 1/2	1	3/4-16	1 1/8	1.5	1/2	1	2 5/16	4 1/8	2 3/8	4 5/8
2 1/2	1 3/8	1-14	1 5/8	2	5/8	1 1/4	2 9/16	4 1/8	2 3/8	4 7/8
3 1/4	1	3/4-16	1 1/8	1.5	1/4	3/4	2 3/8	4 7/8	2 5/8	5
3 1/4	1 3/8	1-14	1 5/8	2	3/8	1	2 5/8	4 7/8	2 5/8	5 1/4
4	1	3/4-16	1 1/8	1.5	1/4	3/4	2 3/8	4 7/8	2 5/8	5
4	1 3/8	1-14	1 5/8	2	3/8	1	2 5/8	4 7/8	2 5/8	5 1/4
5	1	3/4-16	1 1/8	1.5	1/4	3/4	2 5/16	5 1/8	2 7/8	5 1/4
5	1 3/8	1-14	1 5/8	2	3/8	1	2 9/16	5 1/8	2 7/8	5 1/2
5	1 3/4	1 1/4-12	2	2.375	1/2	1 1/4	2 13/16	5 1/8	2 7/8	5 3/4
6	1 3/8	1-14	1 5/8	2	1/4	7/8	2 13/16	5 3/4	3 1/8	5 7/8
6	1 3/4	1 1/4-12	2	2.375	3/8	1 1/8	3 1/16	5 3/4	3 1/8	6 1/8
6	2	1 1/2-12	2 1/4	2.625	3/8	1 1/4	3 3/16	5 3/4	3 1/8	6 1/4

BORE	E	EE(NPT)	F	G	J	K
1 1/2	2	3/8	3/8	2	1	1/4
2	2 1/2	3/8	3/8	2	1	5/16
2 1/2	3	3/8	3/8	2	1 1/8	5/16
3 1/4	3 3/4	1/2	5/8	2 1/4	1 1/4	3/8
4	4 1/2	1/2	5/8	2 1/4	1 1/4	3/8
5	5 1/2	1/2	5/8	2 1/4	1 1/2	7/16
6	6 1/2	3/4	3/4	2 3/4	1 5/8	7/16

BORE	TD	TL	UT
1 1/2	1	1	4
2	1	1	4 1/2
2 1/2	1	1	5
3 1/4	1	1	5 3/4
4	1	1	6 1/2
5	1	1	7 1/2
6	1 3/8	1 3/8	9 1/4

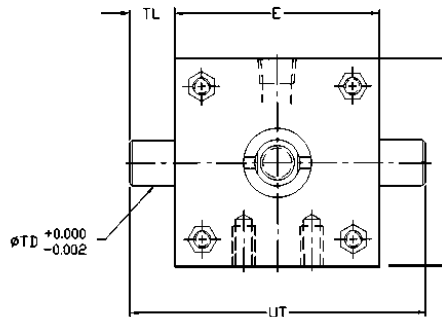
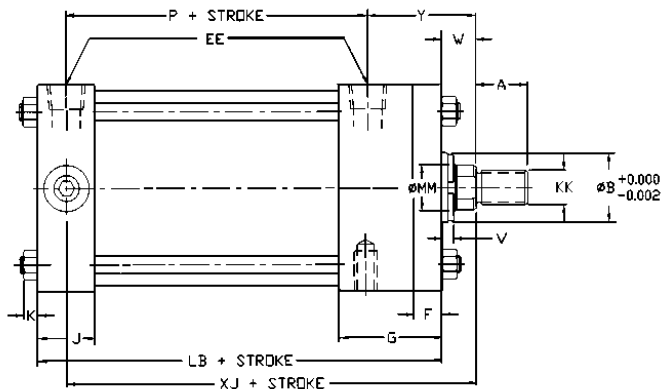

MT4 $\phi 1.5'' \sim 6''$
WITH CENTER TRUNNION

BORE	ROD ϕ MM	KK SM	A	B	V	W	Y	ADD LB	STROKE P	ADD STROKE/2 XI
1 1/2	5/8	7/16-20	3/4	1.125	1/4	5/8	1 15/16	4	2 1/4	3.125
1 1/2	1	3/4-16	1 1/8	1.5	1/2	1	2 5/16	4	2 1/4	3.500
2	5/8	7/16-20	3/4	1.125	1/4	5/8	1 15/16	4	2 1/4	3.125
2	1	3/4-16	1 1/8	1.5	1/2	1	2 5/16	4	2 1/4	3.500
2	1 3/8	1-14	1 5/8	2	5/8	1 1/4	2 9/16	4	2 1/4	3.750
2 1/2	5/8	7/16-20	3/4	1.125	1/4	5/8	1 15/16	4 1/8	2 3/8	3.125
2 1/2	1	3/4-16	1 1/8	1.5	1/2	1	2 5/16	4 1/8	2 3/8	3.500
2 1/2	1 3/8	1-14	1 5/8	2	5/8	1 1/4	2 9/16	4 1/8	2 3/8	3.750
3 1/4	1	3/4-16	1 1/8	1.5	1/4	3/4	2 3/8	4 7/8	2 5/8	3.688
3 1/4	1 3/8	1-14	1 5/8	2	3/8	1	2 5/8	4 7/8	2 5/8	3.938
4	1	3/4-16	1 1/8	1.5	1/4	3/4	2 3/8	4 7/8	2 5/8	3.688
4	1 3/8	1-14	1 5/8	2	3/8	1	2 5/8	4 7/8	2 5/8	3.838
5	1	3/4-16	1 1/8	1.5	1/4	3/4	2 5/16	5 1/8	2 7/8	3.688
5	1 3/8	1-14	1 5/8	2	3/8	1	2 9/16	5 1/8	2 7/8	3.838
5	1 3/4	1 1/4-12	2	2.375	1/2	1 1/4	2 13/16	5 1/8	2 7/8	4.188
6	1 3/8	1-14	1 5/8	2	1/4	7/8	2 13/16	5 3/4	3 1/8	4.313
6	1 3/4	1 1/4-12	2	2.375	3/8	1 1/8	3 1/16	5 3/4	3 1/8	4.563
6	2	1 1/2-12	2 1/4	2.625	3/8	1 1/4	3 3/16	5 3/4	3 1/8	4.688

BORE	BD	E	EE(NPT)	F	G	J	K
1 1/2	1 1/4	2	3/8	3/8	2	1	1/4
2	1 1/4	2 1/2	3/8	3/8	2	1	5/16
2 1/2	1 1/4	3	3/8	3/8	2	1 1/8	5/16
3 1/4	1 1/2	3 3/4	1/2	5/8	2 1/4	1 1/4	3/8
4	1 1/2	4 1/2	1/2	5/8	2 1/4	1 1/4	3/8
5	1 1/2	5 1/2	1/2	5/8	2 1/4	1 1/2	7/16
6	1 3/4	6 1/2	3/4	3/4	2 3/4	1 5/8	7/16

BORE	TD	TL	TM	UM	UW
1 1/2	1	1	2 1/2	4 1/2	2 1/2
2	1	1	3	5	3
2 1/2	1	1	3 1/2	5 1/2	3 1/2
3 1/4	1	1	4 1/2	6 1/2	4 1/2
4	1	1	5 1/4	7 1/4	5 1/4
5	1	1	6 1/4	8 1/4	6 1/4
6	1 3/8	1 3/8	7 5/8	10 3/8	7 5/8

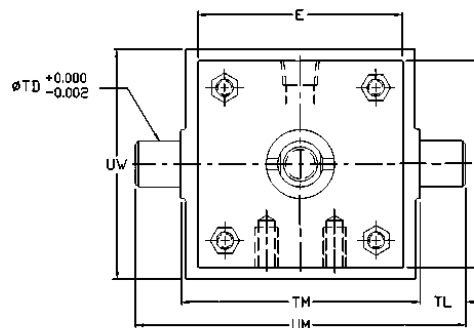
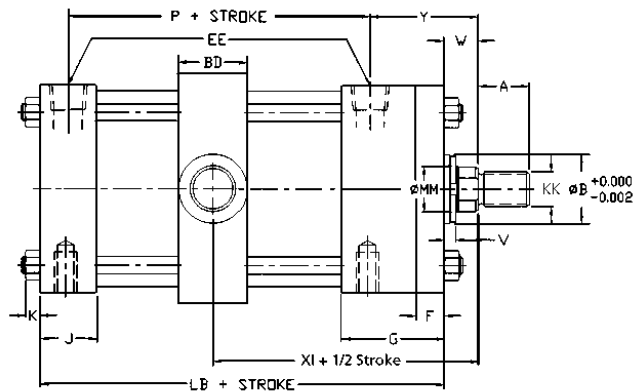

MX1 $\phi 1.5'' \sim 6''$
WITH EXTENDED TIE-RODS / BOTH ENDS

BORE	Rod ϕ MM	KK SM	A	B	V	W	Y	STROKE	
								ADD LB	P
1 1/2	5/8	7/16-20	3/4	1.125	1/4	5/8	1 15/16	4	2 1/4
1 1/2	1	3/4-16	1 1/8	1.5	1/2	1	2 5/16	4	2 1/4
2	5/8	7/16-20	3/4	1.125	1/4	5/8	1 15/16	4	2 1/4
2	1	3/4-16	1 1/8	1.5	1/2	1	2 5/16	4	2 1/4
2	1 3/8	1-14	1 5/8	2	5/8	1 1/4	2 9/16	4	2 1/4
2 1/2	5/8	7/16-20	3/4	1.125	1/4	5/8	1 15/16	4 1/8	2 3/8
2 1/2	1	3/4-16	1 1/8	1.5	1/2	1	2 5/16	4 1/8	2 3/8
2 1/2	1 3/8	1-14	1 5/8	2	5/8	1 1/4	2 9/16	4 1/8	2 3/8
3 1/4	1	3/4-16	1 1/8	1.5	1/4	3/4	2 3/8	4 7/8	2 5/8
3 1/4	1 3/8	1-14	1 5/8	2	3/8	1	2 5/8	4 7/8	2 5/8
4	1	3/4-16	1 1/8	1.5	1/4	3/4	2 3/8	4 7/8	2 5/8
4	1 3/8	1-14	1 5/8	2	3/8	1	2 5/8	4 7/8	2 5/8
5	1	3/4-16	1 1/8	1.5	1/4	3/4	2 5/16	5 1/8	2 7/8
5	1 3/8	1-14	1 5/8	2	3/8	1	2 9/16	5 1/8	2 7/8
5	1 3/4	1 1/4-12	2	2.375	1/2	1 1/4	2 13/16	5 1/8	2 7/8
6	1 3/8	1-14	1 5/8	2	1/4	7/8	2 13/16	5 3/4	3 1/8
6	1 3/4	1 1/4-12	2	2.375	3/8	1 1/8	3 1/16	5 3/4	3 1/8
6	2	1 1/2-12	2 1/4	2.625	3/8	1 1/4	3 3/16	5 3/4	3 1/8

BORE	AA	BB	DD	E	EE(NPT)	F	G	J	K	R
1 1/2	2.02	1	1/4-20	2	3/8	3/8	2	1	1/4	1.43
2	2.60	1 1/8	5/16-24	2 1/2	3/8	3/8	2	1	5/16	1.84
2 1/2	3.10	1 1/8	5/16-24	3	3/8	3/8	2	1 1/8	5/16	2.19
3 1/4	3.90	1 3/8	3/8-24	3 3/4	1/2	5/8	2 1/4	1 1/4	3/8	2.78
4	4.70	1 3/8	3/8-24	4 1/2	1/2	5/8	2 1/4	1 1/4	3/8	3.32
5	5.80	1 13/16	1/2-20	5 1/2	1/2	5/8	2 1/4	1 1/2	7/16	4.10
6	6.90	1 13/16	1/2-20	6 1/2	3/4	3/4	2 3/4	1 5/8	7/16	4.88

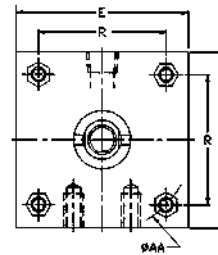
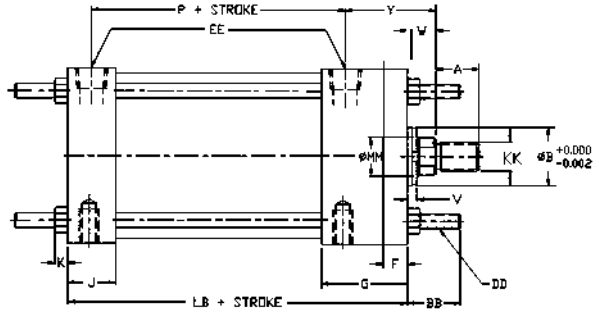

MX2 $\phi 1.5'' \sim 6''$
WITH EXTENDED TIE-RODS / CAP

BORE	Rod ϕ MM	KK SM	A	B	V	W	Y	STROKE	
								ADD LB	P
1 1/2	5/8	7/16-20	3/4	1.125	1/4	5/8	1 15/16	4	2 1/4
1 1/2	1	3/4-16	1 1/8	1.5	1/2	1	2 5/16	4	2 1/4
2	5/8	7/16-20	3/4	1.125	1/4	5/8	1 15/16	4	2 1/4
2	1	3/4-16	1 1/8	1.5	1/2	1	2 5/16	4	2 1/4
2	1 3/8	1-14	1 5/8	2	5/8	1 1/4	2 9/16	4	2 1/4
2 1/2	5/8	7/16-20	3/4	1.125	1/4	5/8	1 15/16	4 1/8	2 3/8
2 1/2	1	3/4-16	1 1/8	1.5	1/2	1	2 5/16	4 1/8	2 3/8
2 1/2	1 3/8	1-14	1 5/8	2	5/8	1 1/4	2 9/16	4 1/8	2 3/8
3 1/4	1	3/4-16	1 1/8	1.5	1/4	3/4	2 3/8	4 7/8	2 5/8
3 1/4	1 3/8	1-14	1 5/8	2	3/8	1	2 5/8	4 7/8	2 5/8
4	1	3/4-16	1 1/8	1.5	1/4	3/4	2 3/8	4 7/8	2 5/8
4	1 3/8	1-14	1 5/8	2	3/8	1	2 5/8	4 7/8	2 5/8
5	1	3/4-16	1 1/8	1.5	1/4	3/4	2 5/16	5 1/8	2 7/8
5	1 3/8	1-14	1 5/8	2	3/8	1	2 9/16	5 1/8	2 7/8
5	1 3/4	1 1/4-12	2	2.375	1/2	1 1/4	2 13/16	5 1/8	2 7/8
6	1 3/8	1-14	1 5/8	2	1/4	7/8	2 13/16	5 3/4	3 1/8
6	1 3/4	1 1/4-12	2	2.375	3/8	1 1/8	3 1/16	5 3/4	3 1/8
6	2	1 1/2-12	2 1/4	2.625	3/8	1 1/4	3 3/16	5 3/4	3 1/8

BORE	AA	BB	DD	E	EE(NPT)	F	G	J	K	R
1 1/2	2.02	1	1/4-20	2	3/8	3/8	2	1	1/4	1.43
2	2.60	1 1/8	5/16-24	2 1/2	3/8	3/8	2	1	5/16	1.84
2 1/2	3.10	1 1/8	5/16-24	3	3/8	3/8	2	1 1/8	5/16	2.19
3 1/4	3.90	1 3/8	3/8-24	3 3/4	1/2	5/8	2 1/4	1 1/4	3/8	2.78
4	4.70	1 3/8	3/8-24	4 1/2	1/2	5/8	2 1/4	1 1/4	3/8	3.32
5	5.80	1 13/16	1/2-20	5 1/2	1/2	5/8	2 1/4	1 1/2	7/16	4.10
6	6.90	1 13/16	1/2-20	6 1/2	3/4	3/4	2 3/4	1 5/8	7/16	4.88

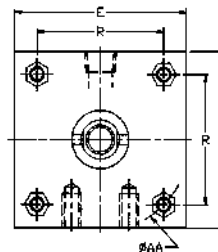
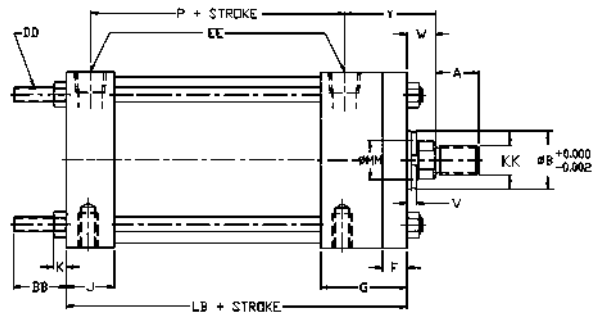

MX3 $\phi 1.5'' \sim 6''$
WITH EXTENDED TIE-RODS / HEAD

BORE	Rod ϕ MM	KK SM	A	B	V	W	Y	Add LB	STROKE P
1 1/2	5/8	7/16-20	3/4	1.125	1/4	5/8	1 15/16	4	2 1/4
1 1/2	1	3/4-16	1 1/8	1.5	1/2	1	2 5/16	4	2 1/4
2	5/8	7/16-20	3/4	1.125	1/4	5/8	1 15/16	4	2 1/4
2	1	3/4-16	1 1/8	1.5	1/2	1	2 5/16	4	2 1/4
2	1 3/8	1-14	1 5/8	2	5/8	1 1/4	2 9/16	4	2 1/4
2 1/2	5/8	7/16-20	3/4	1.125	1/4	5/8	1 15/16	4 1/8	2 3/8
2 1/2	1	3/4-16	1 1/8	1.5	1/2	1	2 5/16	4 1/8	2 3/8
2 1/2	1 3/8	1-14	1 5/8	2	5/8	1 1/4	2 9/16	4 1/8	2 3/8
3 1/4	1	3/4-16	1 1/8	1.5	1/4	3/4	2 3/8	4 7/8	2 5/8
3 1/4	1 3/8	1-14	1 5/8	2	3/8	1	2 5/8	4 7/8	2 5/8
4	1	3/4-16	1 1/8	1.5	1/4	3/4	2 3/8	4 7/8	2 5/8
4	1 3/8	1-14	1 5/8	2	3/8	1	2 5/8	4 7/8	2 5/8
5	1	3/4-16	1 1/8	1.5	1/4	3/4	2 5/16	5 1/8	2 7/8
5	1 3/8	1-14	1 5/8	2	3/8	1	2 9/16	5 1/8	2 7/8
5	1 3/4	1 1/4-12	2	2.375	1/2	1 1/4	2 13/16	5 1/8	2 7/8
6	1 3/8	1-14	1 5/8	2	1/4	7/8	2 13/16	5 3/4	3 1/8
6	1 3/4	1 1/4-12	2	2.375	3/8	1 1/8	3 1/16	5 3/4	3 1/8
6	2	1 1/2-12	2 1/4	2.625	3/8	1 1/4	3 3/16	5 3/4	3 1/8

BORE	AA	BB	DD	E	EE(NPT)	F	G	J	K	R
1 1/2	2.02	1	1/4-20	2	3/8	3/8	2	1	1/4	1.43
2	2.60	1 1/8	5/16-24	2 1/2	3/8	3/8	2	1	5/16	1.84
2 1/2	3.10	1 1/8	5/16-24	3	3/8	3/8	2	1 1/8	5/16	2.19
3 1/4	3.90	1 3/8	3/8-24	3 3/4	1/2	5/8	2 1/4	1 1/4	3/8	2.78
4	4.70	1 3/8	3/8-24	4 1/2	1/2	5/8	2 1/4	1 1/4	3/8	3.32
5	5.80	1 13/16	1/2-20	5 1/2	1/2	5/8	2 1/4	1 1/2	7/16	4.10
6	6.90	1 13/16	1/2-20	6 1/2	3/4	3/4	2 3/4	1 5/8	7/16	4.88

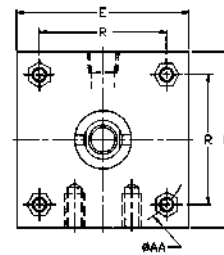
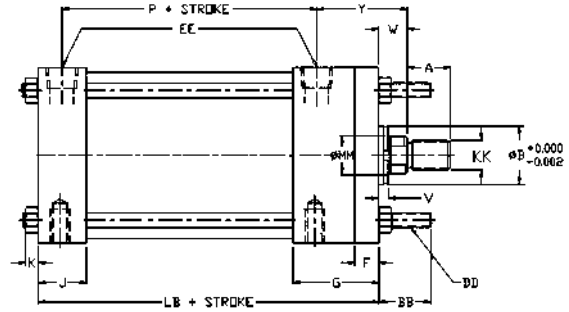

ME3 $\phi 8'' \sim 14''$
WITH HEAD SQUARE MOUNT

BORE	Rod ϕ MM	KK SM	A	B	V	W	Y
8	1 3/8	1-14	1 5/8	2	1/4	7/8	2 13/16
8	1 3/4	1 1/4-12	2	2.375	3/8	1 1/8	3 1/16
8	2	1 1/2-12	2 1/4	2.625	3/8	1 1/4	3 3/16
8	2 1/2	1 7/8-12	3	3.125	1/2	1 1/2	3 7/16
10	1 3/4	1 1/4-12	2	2.375	3/8	1 1/8	3 1/8
10	2	1 1/2-12	2 1/4	2.625	3/8	1 1/4	3 1/4
10	2 1/2	1 7/8-12	3	3.125	1/2	1 1/2	3 1/2
12	2	1 1/2-12	2 1/4	2.625	3/8	1 1/4	3 1/4
12	2 1/2	1 7/8-12	3	3.125	1/2	1 1/2	3 1/2
12	3	2 1/4-12	3 1/2	3.75	1/2	1 1/2	3 1/2
14	2 1/2	1 7/8-12	3	3.125	1/2	1 1/2	3 13/16
14	3	2 1/4-12	3 1/2	3.75	1/2	1 1/2	3 13/16
14	3 1/2	2 1/2-12	3 1/2	4.25	1/2	1 1/2	3 13/16

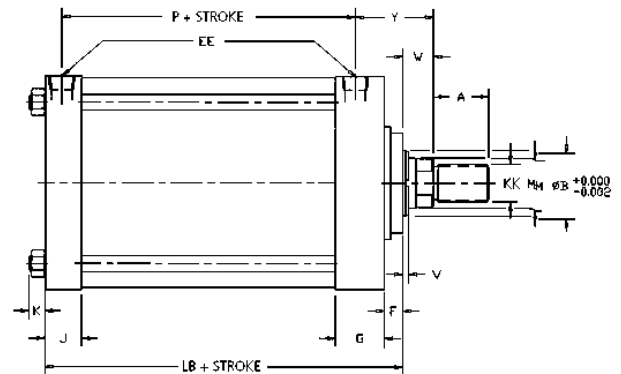

BORE	E	EE(NPT)	EB	F	G	J	K	RD	TE	Add LB	STROKE P
8	8 1/2	3/4	11/16	3/4	2	1 1/2	9/16	4 1/2	7.57	5 7/8	3 1/4
10	10 5/8	1	13/16	3/4	2 1/4	2	11/16	4 1/2	9.40	7 1/8	4 1/8
12	12 3/4	1	13/16	3/4	2 1/4	2	11/16	5 1/2	11.10	7 5/8	4 5/8
14	14 3/4	1 1/4	15/16	3/4	2 3/4	2 1/4	3/4	6	12.87	8 7/8	5 1/2

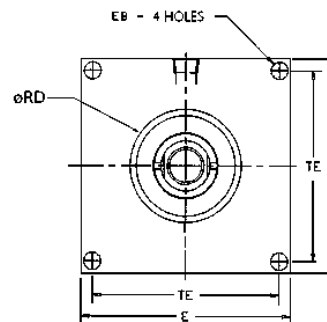

ME4 $\varnothing 8'' \sim 14''$
WITH CAP SQUARE MOUNT

BORE	Rod \varnothing MM	KK SM	A	B	V	W	Y
8	1 3/8	1-14	1 5/8	2	1/4	7/8	2 13/16
8	1 3/4	1 1/4-12	2	2.375	3/8	1 1/8	3 1/16
8	2	1 1/2-12	2 1/4	2.625	3/8	1 1/4	3 3/16
8	2 1/2	1 7/8-12	3	3.125	1/2	1 1/2	3 7/16
10	1 3/4	1 1/4-12	2	2.375	3/8	1 1/8	3 1/8
10	2	1 1/2-12	2 1/4	2.625	3/8	1 1/4	3 1/4
10	2 1/2	1 7/8-12	3	3.125	1/2	1 1/2	3 1/2
12	2	1 1/2-12	2 1/4	2.625	3/8	1 1/4	3 1/4
12	2 1/2	1 7/8-12	3	3.125	1/2	1 1/2	3 1/2
12	3	2 1/4-12	3 1/2	3.75	1/2	1 1/2	3 1/2
14	2 1/2	1 7/8-12	3	3.125	1/2	1 1/2	3 13/16
14	3	2 1/4-12	3 1/2	3.75	1/2	1 1/2	3 13/16
14	3 1/2	2 1/2-12	3 1/2	4.25	1/2	1 1/2	3 13/16

BORE	E	EE(NPT)	EB	F	G
8	8 1/2	3/4	11/16	3/4	2
10	10 5/8	1	13/16	3/4	2 1/4
12	12 3/4	1	13/16	3/4	2 1/4
14	14 3/4	1 1/4	15/16	3/4	2 3/4

BORE	J	K	TE	Add LB	STROKE P
8	1 1/2	9/16	7.57	5 7/8	3 1/4
10	2	11/16	9.40	7 1/8	4 1/8
12	2	11/16	11.10	7 5/8	4 5/8
14	2 1/4	3/4	12.87	8 7/8	5 1/2

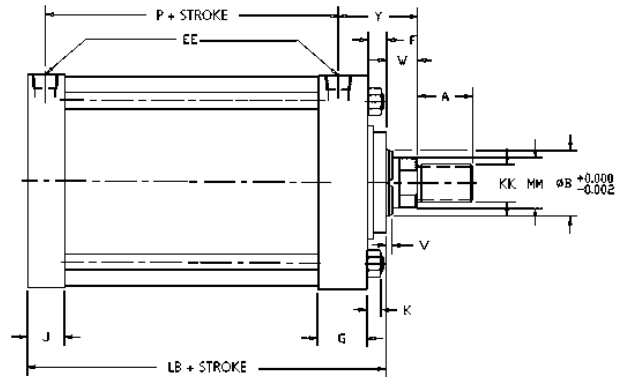
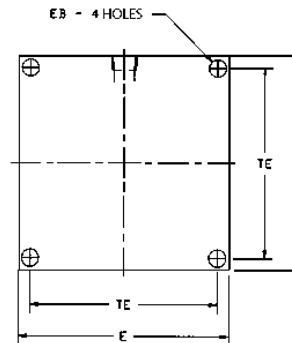

MP1 $\varnothing 8'' \sim 14''$
WITH DOUBLE REAR CLEVIS

BORE	Rod \varnothing MM	KK SM	A	B	V	W	Y	Add STROKE		
								LB	P	XC
8	1 3/8	1-14	1 5/8	2	1/4	7/8	2 13/16	5 7/8	3 1/4	8 1/4
8	1 3/4	1 1/4-12	2	2.375	3/8	1 1/8	3 1/16	5 7/8	3 1/4	8 1/2
8	2	1 1/2-12	2 1/4	2.625	3/8	1 1/4	3 3/16	5 7/8	3 1/4	8 5/8
8	2 1/2	1 7/8-12	3	3.125	1/2	1 1/2	3 7/16	5 7/8	3 1/4	8 7/8
10	1 3/4	1 1/4-12	2	2.375	3/8	1 1/8	3 1/8	7 1/8	4 1/8	10 3/8
10	2	1 1/2-12	2 1/4	2.625	3/8	1 1/4	3 1/4	7 1/8	4 1/8	10 1/2
10	2 1/2	1 7/8-12	3	3.125	1/2	1 1/2	3 1/2	7 1/8	4 1/8	10 3/4
12	2	1 1/2-12	2 1/4	2.625	3/8	1 1/4	3 1/4	7 5/8	4 5/8	11 1/8
12	2 1/2	1 7/8-12	3	3.125	1/2	1 1/2	3 1/2	7 5/8	4 5/8	11 3/8
12	3	2 1/4-12	3 1/2	3.75	1/2	1 1/2	3 1/2	7 5/8	4 5/8	11 3/8
14	2 1/2	1 7/8-12	3	3.125	1/2	1 1/2	3 13/16	8 7/8	5 1/2	12 7/8
14	3	2 1/4-12	3 1/2	3.75	1/2	1 1/2	3 13/16	8 7/8	5 1/2	12 7/8
14	3 1/2	2 1/2-12	3 1/2	4.25	1/2	1 1/2	3 13/16	8 7/8	5 1/2	12 7/8

BORE	CB	CD	CW	E	EE(NPT)
8	1 1/2	1.001	3/4	8 1/2	3/4
10	2	1.376	1	10 5/8	1
12	2 1/2	1.751	1 1/4	12 3/4	1
14	2 1/2	2.001	1 1/4	14 3/4	1 1/4

BORE	F	G	J	K	L	MR
8	3/4	2	1 1/2	9/16	1 1/2	1 3/16
10	3/4	2 1/4	2	11/16	2 1/8	1 5/8
12	3/4	2 1/4	2	11/16	2 1/4	2 1/8
14	3/4	2 3/4	2 1/4	3/4	2 1/2	2 3/8

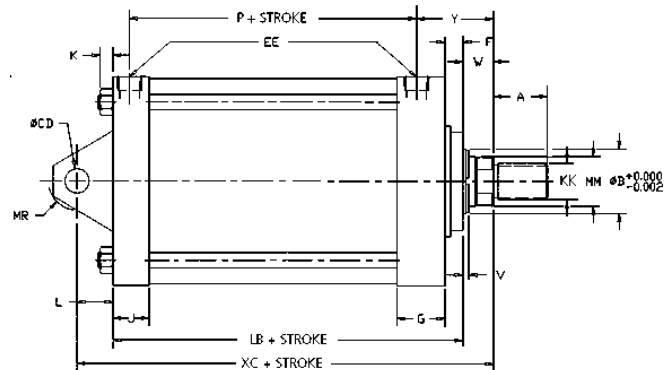
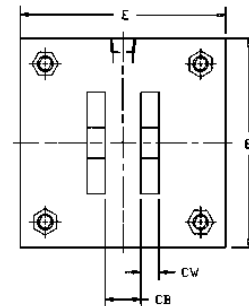

MP2 $\varnothing 8'' \sim 14''$
WITH DOUBLE DETACHABLE REAR CLEVIS

BORE	ROD \varnothing MM	KK SM	A	B	V	W	Y	ADD STROKE		
								LB	P	XD
8	1 3/8	1-14	1 5/8	2	1/4	7/8	2 13/16	5 7/8	3 1/4	9
8	1 3/4	1 1/4-12	2	2.375	3/8	1 1/8	3 1/16	5 7/8	3 1/4	9 1/4
8	2	1 1/2-12	2 1/4	2.625	3/8	1 1/4	3 3/16	5 7/8	3 1/4	9 3/8
8	2 1/2	1 7/8-12	3	3.125	1/2	1 1/2	3 7/16	5 7/8	3 1/4	9 5/8
10	1 3/4	1 1/4-12	2	2.375	3/8	1 1/8	3 1/8	7 1/8	4 1/8	11 1/8
10	2	1 1/2-12	2 1/4	2.625	3/8	1 1/4	3 1/4	7 1/8	4 1/8	11 1/4
10	2 1/2	1 7/8-12	3	3.125	1/2	1 1/2	3 1/2	7 1/8	4 1/8	11 1/2
12	2	1 1/2-12	2 1/4	2.625	3/8	1 1/4	3 1/4	7 5/8	4 5/8	11 7/8
12	2 1/2	1 7/8-12	3	3.125	1/2	1 1/2	3 1/2	7 5/8	4 5/8	12 1/8
12	3	2 1/4-12	3 1/2	3.75	1/2	1 1/2	3 1/2	7 5/8	4 5/8	12 1/8
14	2 1/2	1 7/8-12	3	3.125	1/2	1 1/2	3 13/16	8 7/8	5 1/2	13 5/8
14	3	2 1/4-12	3 1/2	3.75	1/2	1 1/2	3 13/16	8 7/8	5 1/2	13 5/8
14	3 1/2	2 1/2-12	3 1/2	4.25	1/2	1 1/2	3 13/16	8 7/8	5 1/2	13 5/8

BORE	CB	CD	CW	E	EE(NPT)	F	G	J	K	MR
8	1 1/2	1.001	3/4	8 1/2	3/4	3/4	2	1 1/2	9/16	1 3/16
10	2	1.376	1	10 5/8	1	3/4	2 1/4	2	11/16	1 5/8
12	2 1/2	1.751	1 1/4	12 3/4	1	3/4	2 1/4	2	11/16	2 1/8
14	2 1/2	2.001	1 1/4	14 3/4	1 1/4	3/4	2 3/4	2 1/4	3/4	2 3/8

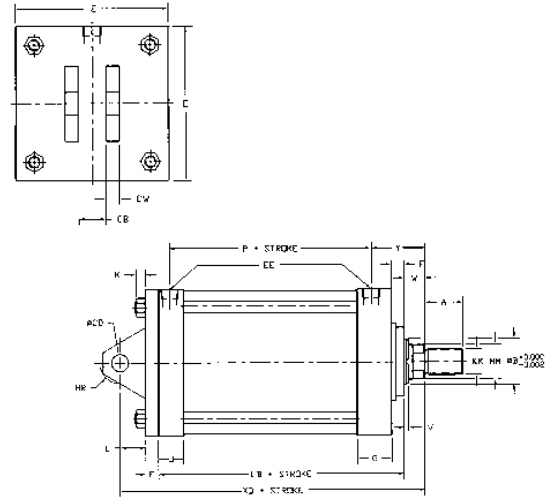

MP3 $\varnothing 8'' \sim 14''$
WITH CAP FIXED EYE

BORE	ROD \varnothing MM	KK SM	A	B	V	W	Y	ADD STROKE		
								LB	P	XC
8	1 3/8	1-14	1 5/8	2	1/4	7/8	2 13/16	5 7/8	3 1/4	8 1/4
8	1 3/4	1 1/4-12	2	2.375	3/8	1 1/8	3 1/16	5 7/8	3 1/4	8 1/2
8	2	1 1/2-12	2 1/4	2.625	3/8	1 1/4	3 3/16	5 7/8	3 1/4	8 5/8
8	2 1/2	1 7/8-12	3	3.125	1/2	1 1/2	3 7/16	5 7/8	3 1/4	8 7/8
10	1 3/4	1 1/4-12	2	2.375	3/8	1 1/8	3 1/8	7 1/8	4 1/8	10 3/8
10	2	1 1/2-12	2 1/4	2.625	3/8	1 1/4	3 1/4	7 1/8	4 1/8	10 1/2
10	2 1/2	1 7/8-12	3	3.125	1/2	1 1/2	3 1/2	7 1/8	4 1/8	10 3/4
12	2	1 1/2-12	2 1/4	2.625	3/8	1 1/4	3 1/4	7 5/8	4 5/8	11 1/8
12	2 1/2	1 7/8-12	3	3.125	1/2	1 1/2	3 1/2	7 5/8	4 5/8	11 3/8
12	3	2 1/4-12	3 1/2	3.75	1/2	1 1/2	3 1/2	7 5/8	4 5/8	11 3/8
14	2 1/2	1 7/8-12	3	3.125	1/2	1 1/2	3 13/16	8 7/8	5 1/2	12 7/8
14	3	2 1/4-12	3 1/2	3.75	1/2	1 1/2	3 13/16	8 7/8	5 1/2	12 7/8
14	3 1/2	2 1/2-12	3 1/2	4.25	1/2	1 1/2	3 13/16	8 7/8	5 1/2	12 7/8

BORE	CB	CD	E	EE(NPT)	F	G	J	K	L	MR
8	1 1/2	1.001	8 1/2	3/4	3/4	2	1 1/2	9/16	1 1/2	1 3/16
10	2	1.376	10 5/8	1	3/4	2 1/4	2	11/16	2 1/8	1 5/8
12	2 1/2	1.751	12 3/4	1	3/4	2 1/4	2	11/16	2 1/8	2 1/8
14	2 1/2	2.001	14 3/4	1 1/4	3/4	2 3/4	2 1/4	3/4	2 1/2	2 3/8

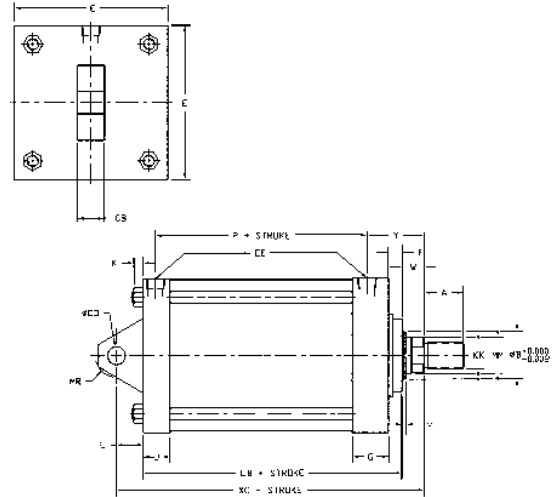

MP4 $\varnothing 8'' \sim 14''$
WITH SINGLE DETACHABLE REAR CLEVIS

BORE	ROD \varnothing MM	KK SM	A	B	V	W	Y	ADD STROKE		
								LB	P	XD
8	1 3/8	1-14	1 5/8	2	1/4	7/8	2 13/16	5 7/8	3 1/4	9
8	1 3/4	1 1/4-12	2	2.375	3/8	1 1/8	3 1/16	5 7/8	3 1/4	9 1/4
8	2	1 1/2-12	2 1/4	2.625	3/8	1 1/4	3 3/16	5 7/8	3 1/4	9 3/8
8	2 1/2	1 7/8-12	3	3.125	1/2	1 1/2	3 7/16	5 7/8	3 1/4	9 5/8
10	1 3/4	1 1/4-12	2	2.375	3/8	1 1/8	3 1/8	7 1/8	4 1/8	11 1/8
10	2	1 1/2-12	2 1/4	2.625	3/8	1 1/4	3 1/4	7 1/8	4 1/8	11 1/4
10	2 1/2	1 7/8-12	3	3.125	1/2	1 1/2	3 1/2	7 1/8	4 1/8	11 1/2
12	2	1 1/2-12	2 1/4	2.625	3/8	1 1/4	3 1/4	7 5/8	4 5/8	11 7/8
12	2 1/2	1 7/8-12	3	3.125	1/2	1 1/2	3 1/2	7 5/8	4 5/8	12 1/8
12	3	2 1/4-12	3 1/2	3.75	1/2	1 1/2	3 1/2	7 5/8	4 5/8	12 1/8
14	2 1/2	1 7/8-12	3	3.125	1/2	1 1/2	3 13/16	8 7/8	5 1/2	13 5/8
14	3	2 1/4-12	3 1/2	3.75	1/2	1 1/2	3 13/16	8 7/8	5 1/2	13 5/8
14	3 1/2	2 1/2-12	3 1/2	4.25	1/2	1 1/2	3 13/16	8 7/8	5 1/2	13 5/8

BORE	CB	CD	E	EE(NPT)	F	G	J	K	MR
8	1 1/2	1.001	8 1/2	3/4	3/4	2	1 1/2	9/16	1 3/16
10	2	1.376	10 5/8	1	3/4	2 1/4	2	11/16	1 5/8
12	2 1/2	1.751	12 3/4	1	3/4	2 1/4	2	11/16	2 1/8
14	2 1/2	2.001	14 3/4	1 1/4	3/4	2 3/4	2 1/4	3/4	2 3/8

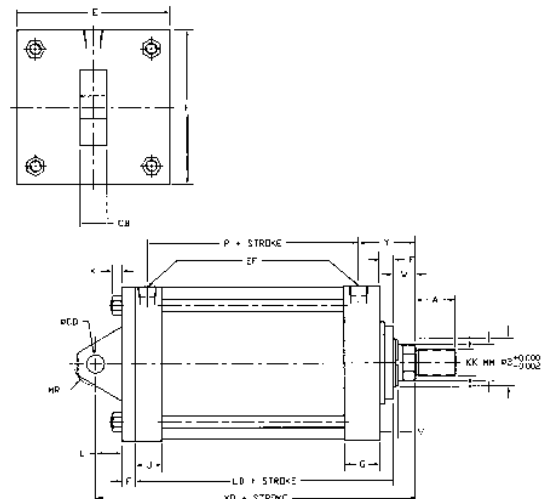

MS1 $\varnothing 8'' \sim 14''$
WITH FOOT MOUNT

BORE	ROD \varnothing MM	KK SM	A	B	V	W	Y
8	1 3/8	1-14	1 5/8	2	1/4	7/8	2 13/16
8	1 3/4	1 1/4-12	2	2.375	3/8	1 1/8	3 1/16
8	2	1 1/2-12	2 1/4	2.625	3/8	1 1/4	3 3/16
8	2 1/2	1 7/8-12	3	3.125	1/2	1 1/2	3 7/16
10	1 3/4	1 1/4-12	2	2.375	3/8	1 1/8	3 1/8
10	2	1 1/2-12	2 1/4	2.625	3/8	1 1/4	3 1/4
10	2 1/2	1 7/8-12	3	3.125	1/2	1 1/2	3 1/2
12	2	1 1/2-12	2 1/4	2.625	3/8	1 1/4	3 1/4
12	2 1/2	1 7/8-12	3	3.125	1/2	1 1/2	3 1/2
12	3	2 1/4-12	3 1/2	3.75	1/2	1 1/2	3 1/2
14	2 1/2	1 7/8-12	3	3.125	1/2	1 1/2	3 13/16
14	3	2 1/4-12	3 1/2	3.75	1/2	1 1/2	3 13/16
14	3 1/2	2 1/2-12	3 1/2	4.25	1/2	1 1/2	3 13/16

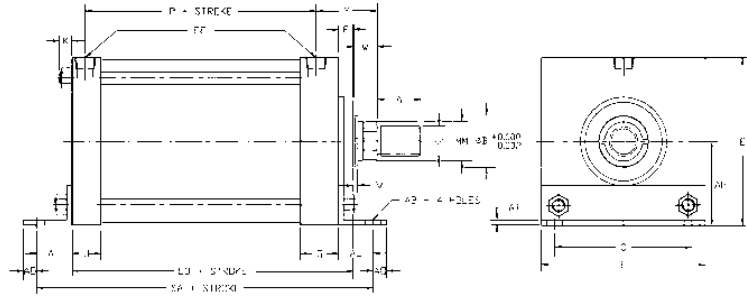

BORE	AB	AH	AL	AO	AT	E	EE(NPT)	F	G	J	K	S	ADD STROKE		
													LB	P	SA
8	13/16	4 1/4	1 13/16	11/16	1/4	8 1/2	3/4	3/4	2	1 1/2	9/16	7 1/8	5 7/8	3 1/4	8 3/4
10	1 1/16	5 5/16	2 1/8	7/8	1/4	10 5/8	1	3/4	2 1/4	2	11/16	8 7/8	7 1/8	4 1/8	10 5/8
12	1 1/16	6 3/8	2 1/8	7/8	3/8	12 3/4	1	3/4	2 1/4	2	11/16	11	7 5/8	4 5/8	11 1/8
14	1 5/16	7 3/8	2 7/16	2 7/16	3/8	14 3/4	1 1/4	3/4	2 3/4	2 1/4	3/4	12 5/8	8 7/8	5 1/2	13

MS2 $\varnothing 8'' \sim 14''$
WITH SIDE LUG

BORE	ROD (MM)	KK SM	A	B	V	W	XS	Y
8	1 3/8	1-14	1 5/8	2	1/4	7/8	2 5/16	2 13/16
8	1 3/4	1 1/4-12	2	2.375	3/8	1 1/8	2 9/16	3 1/16
8	2	1 1/2-12	2 1/4	2.625	3/8	1 1/4	2 11/16	3 3/16
8	2 1/2	1 7/8-12	3	3.125	1/2	1 1/2	2 15/18	3 7/16
10	1 3/4	1 1/4-12	2	2.375	3/8	1 1/8	2 3/4	3 1/8
10	2	1 1/2-12	2 1/4	2.625	3/8	1 1/4	2 7/8	3 1/4
10	2 1/2	1 7/8-12	3	3.125	1/2	1 1/2	3 1/8	3 1/2
12	2	1 1/2-12	2 1/4	2.625	3/8	1 1/4	2 7/8	3 1/4
12	2 1/2	1 7/8-12	3	3.125	1/2	1 1/2	3 1/8	3 1/2
12	3	2 1/4-12	3 1/2	3.75	1/2	1 1/2	3 1/8	3 1/2
14	2 1/2	1 7/8-12	3	3.125	1/2	1 1/2	3 3/8	3 13/16
14	3	2 1/4-12	3 1/2	3.75	1/2	1 1/2	3 3/8	3 13/16
14	3 1/2	2 1/2-12	3 1/2	4.25	1/2	1 1/2	3 3/8	3 13/16

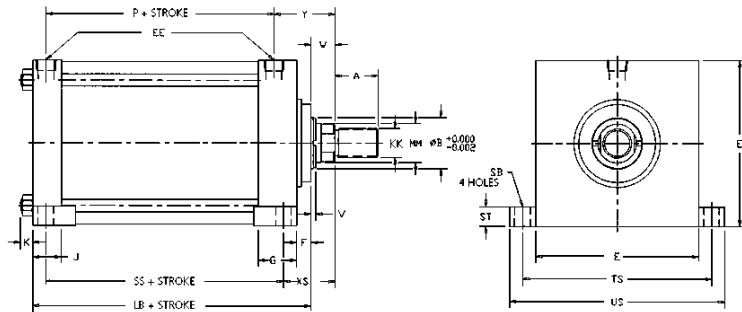

BORE	E	EE(NPT)	F	G	J	K	SB	ST	TS	US	ADD STROKE		
											LB	P	SS
8	8 1/2	3/4	3/4	2	1 1/2	9/16	13/16	1	9 7/8	11 1/4	5 7/8	3 1/4	3 3/4
10	10 5/8	1	3/4	2 1/4	2	11/16	1 1/16	1 1/4	12 3/8	14 1/8	7 1/8	4 1/8	4 5/8
12	12 3/4	1	3/4	2 1/4	2	11/16	11/16	1 1/4	14 1/2	16 1/4	7 5/8	4 5/8	5 1/8
14	14 3/4	1 1/4	3/4	2 3/4	2 1/4	3/4	1 5/16	1 1/2	17	19 1/4	8 7/8	5 1/2	5 7/8

MS3 $\varnothing 8'' \sim 14''$
WITH CENTERLINE LUG

BORE	ROD (MM)	KK SM	A	B	V	W	XS	Y
8	1 3/8	1-14	1 5/8	2	1/4	7/8	2 5/16	2 13/16
8	1 3/4	1 1/4-12	2	2.375	3/8	1 1/8	2 9/16	3 1/16
8	2	1 1/2-12	2 1/4	2.625	3/8	1 1/4	2 11/16	3 3/16
8	2 1/2	1 7/8-12	3	3.125	1/2	1 1/2	2 15/18	3 7/16
10	1 3/4	1 1/4-12	2	2.375	3/8	1 1/8	2 3/4	3 1/8
10	2	1 1/2-12	2 1/4	2.625	3/8	1 1/4	2 7/8	3 1/4
10	2 1/2	1 7/8-12	3	3.125	1/2	1 1/2	3 1/8	3 1/2
12	2	1 1/2-12	2 1/4	2.625	3/8	1 1/4	2 7/8	3 1/4
12	2 1/2	1 7/8-12	3	3.125	1/2	1 1/2	3 1/8	3 1/2
12	3	2 1/4-12	3 1/2	3.75	1/2	1 1/2	3 1/8	3 1/2
14	2 1/2	1 7/8-12	3	3.125	1/2	1 1/2	3 3/8	3 13/16
14	3	2 1/4-12	3 1/2	3.75	1/2	1 1/2	3 3/8	3 13/16
14	3 1/2	2 1/2-12	3 1/2	4.25	1/2	1 1/2	3 3/8	3 13/16

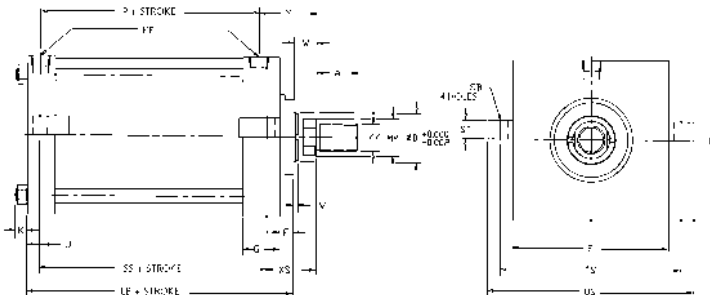

BORE	E	EE(NPT)	F	G	J	K	SB	ST	TS	US	ADD STROKE		
											LB	P	SS
8	8 1/2	3/4	3/4	2	1 1/2	9/16	13/16	1	9 7/8	11 1/4	5 7/8	3 1/4	3 3/4
10	10 5/8	1	3/4	2 1/4	2	11/16	1 1/16	1 1/4	12 3/8	14 1/8	7 1/8	4 1/8	4 5/8
12	12 3/4	1	3/4	2 1/4	2	11/16	11/16	1 1/4	14 1/2	16 1/4	7 5/8	4 5/8	5 1/8
14	14 3/4	1 1/4	3/4	2 3/4	2 1/4	3/4	1 5/16	1 1/2	17	19 1/4	8 7/8	5 1/2	5 7/8

MS4 $\varnothing 8'' \sim 14''$

SIDE-TAPPED

BORE	ROD (MM)	KK SM	A	B	V	W	XT	Y
8	1 3/8	1-14	1 5/8	2	1/4	7/8	2 13/16	2 13/16
8	1 3/4	1 1/4-12	2	2.375	3/8	1 1/8	3 1/16	3 1/16
8	2	1 1/2-12	2 1/4	2.625	3/8	1 1/4	3 3/16	3 3/16
8	2 1/2	1 7/8-12	3	3.125	1/2	1 1/2	3 7/16	3 7/16
10	1 3/4	1 1/4-12	2	2.375	3/8	1 1/8	3 1/8	3 1/8
10	2	1 1/2-12	2 1/4	2.625	3/8	1 1/4	3 1/4	3 1/4
10	2 1/2	1 7/8-12	3	3.125	1/2	1 1/2	3 1/2	3 1/2
12	2	1 1/2-12	2 1/4	2.625	3/8	1 1/4	3 1/4	3 1/4
12	2 1/2	1 7/8-12	3	3.125	1/2	1 1/2	3 1/2	3 1/2
12	3	2 1/4-12	3 1/2	3.75	1/2	1 1/2	3 1/2	3 1/2
14	2 1/2	1 7/8-12	3	3.125	1/2	1 1/2	3 13/16	3 13/16
14	3	2 1/4-12	3 1/2	3.75	1/2	1 1/2	3 13/16	3 13/16
14	3 1/2	2 1/2-12	3 1/2	4.25	1/2	1 1/2	3 13/16	3 13/16

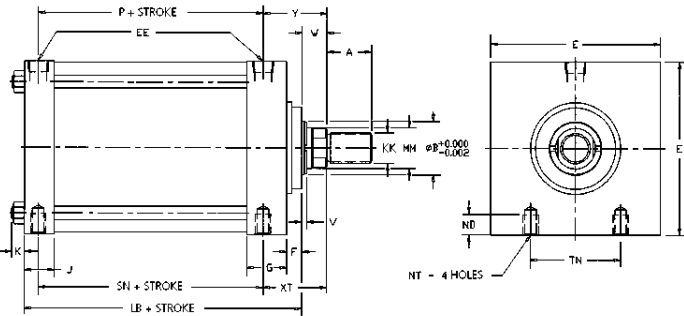

BORE	E	EE(NPT)	F	G	J	K	ND	NT	TN	ADD STROKE		
										LB	P	SN
8	8 1/2	3/4	3/4	2	1 1/2	9/16	1 1/8	3/4-10	4 1/2	5 7/8	3 1/4	3 1/4
10	10 5/8	1	3/4	2 1/4	2	11/16	1 1/2	1-8	5 1/2	7 1/8	4 1/8	4 1/8
12	12 3/4	1	3/4	2 1/4	2	11/16	1 1/2	1-8	7 1/4	7 5/8	4 5/8	4 5/8
14	14 3/4	1 1/4	3/4	2 3/4	2 1/4	3/4	1 7/8	1 1/4-7	8 3/8	8 7/8	5 1/2	5 1/2

MS7 $\varnothing 8'' \sim 14''$

WITH FRONT LUG MOUNT

BORE	ROD (MM)	KK SM	A	B	V	W	Y
8	1 3/8	1-14	1 5/8	2	1/4	7/8	2 13/16
8	1 3/4	1 1/4-12	2	2.375	3/8	1 1/8	3 1/16
8	2	1 1/2-12	2 1/4	2.625	3/8	1 1/4	3 3/16
8	2 1/2	1 7/8-12	3	3.125	1/2	1 1/2	3 7/16
10	1 3/4	1 1/4-12	2	2.375	3/8	1 1/8	3 1/8
10	2	1 1/2-12	2 1/4	2.625	3/8	1 1/4	3 1/4
10	2 1/2	1 7/8-12	3	3.125	1/2	1 1/2	3 1/2
12	2	1 1/2-12	2 1/4	2.625	3/8	1 1/4	3 1/4
12	2 1/2	1 7/8-12	3	3.125	1/2	1 1/2	3 1/2
12	3	2 1/4-12	3 1/2	3.75	1/2	1 1/2	3 1/2
14	2 1/2	1 7/8-12	3	3.125	1/2	1 1/2	3 13/16
14	3	2 1/4-12	3 1/2	3.75	1/2	1 1/2	3 13/16
14	3 1/2	2 1/2-12	3 1/2	4.25	1/2	1 1/2	3 13/16

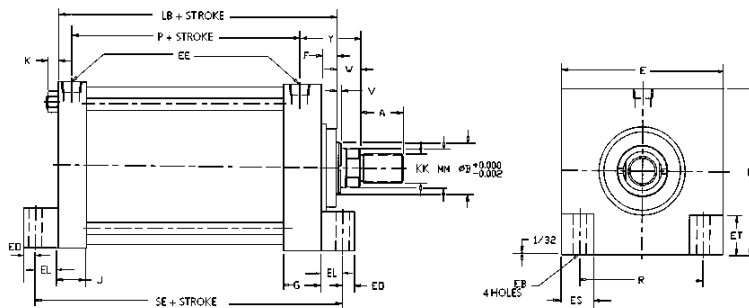

BORE	E	EB	EE(NPT)	EL	EO	ES	ET	F	G	J	K	R	ADD STROKE		
													LB	P	SE
8	8 1/2	11/16	3/4	1 1/8	5/8	2 1/4	2 1/32	3/4	2	1 1/2	9/16	6.44	5 7/8	3 1/4	7 3/8
10	10 5/8	13/16	1	1 5/16	5/8	2 3/4	2 11/16	3/4	2 1/4	2	11/16	7.92	7 1/8	4 1/8	9
12	12 3/4	13/16	1	1 5/16	5/8	3 1/2	3 5/16	3/4	2 1/4	2	11/16	9.40	7 5/8	4 5/8	9 1/2
14	14 3/4	15/16	1 1/4	1 1/2	3/4	4	3 13/16	3/4	2 3/4	2 1/4	3/4	10.90	8 7/8	5 1/2	11 1/8

MT1 $\varnothing 8'' \sim 14''$

WITH HEAD TRUNNION

BORE	ROD (MM)	KK SM	A	B	V	W	XG	Y
8	1 3/8	1-14	1 5/8	2	1/4	7/8	2 5/8	2 13/16
8	1 3/4	1 1/4-12	2	2.375	3/8	1 1/8	2 7/8	3 1/16
8	2	1 1/2-12	2 1/4	2.625	3/8	1 1/4	3	3 3/16
8	2 1/2	1 7/8-12	3	3.125	1/2	1 1/2	3 1/4	3 7/16
10	1 3/4	1 1/4-12	2	2.375	3/8	1 1/8	3	3 1/8
10	2	1 1/2-12	2 1/4	2.625	3/8	1 1/4	3 1/8	3 1/4
10	2 1/2	1 7/8-12	3	3.125	1/2	1 1/2	3 3/8	3 1/2
12	2	1 1/2-12	2 1/4	2.625	3/8	1 1/4	3 1/8	3 1/4
12	2 1/2	1 7/8-12	3	3.125	1/2	1 1/2	3 3/8	3 1/2
12	3	2 1/4-12	3 1/2	3.75	1/2	1 1/2	3 3/8	3 1/2
14	2 1/2	1 7/8-12	3	3.125	1/2	1 1/2	3 5/8	3 13/16
14	3	2 1/4-12	3 1/2	3.75	1/2	1 1/2	3 5/8	3 13/16
14	3 1/2	2 1/2-12	3 1/2	4.25	1/2	1 1/2	3 5/8	3 13/16

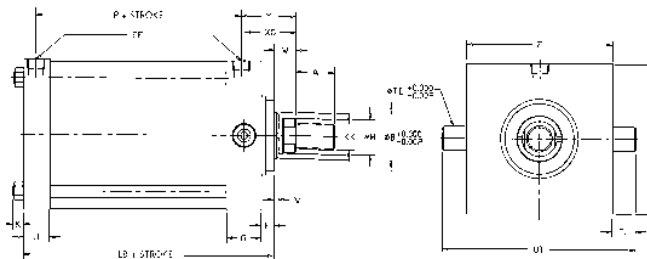

BORE	E	EE(NPT)	F	G	J	K	TD	TL	UT	ADD STROKE	
										LB	P
8	8 1/2	3/4	3/4	2	1 1/2	9/16	1.375	1 3/8	11 1/4	5 7/8	3 1/4
10	10 5/8	1	3/4	2 1/4	2	11/16	1.750	1 3/4	14 1/8	7 1/8	4 1/8
12	12 3/4	1	3/4	2 1/4	2	11/16	1.750	1 3/4	16 1/4	7 5/8	4 5/8
14	14 3/4	1 1/4	3/4	2 3/4	2 1/4	3/4	2.000	2	18 3/4	8 7/8	5 1/2

**MT2 $\varnothing 8'' \sim 14''$
WITH REAR TRUNNION**

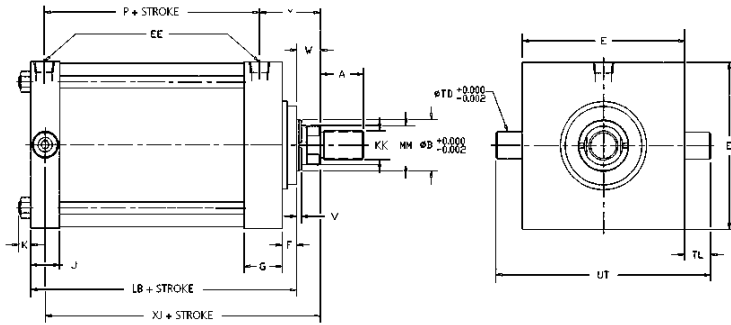

BORE	E	EE(NPT)	F	G	J
8	8 1/2	3/4	3/4	2	1 1/2
10	10 5/8	1	3/4	2 1/4	2
12	12 3/4	1	3/4	2 1/4	2
14	14 3/4	1 1/4	3/4	2 3/4	2 1/4

BORE	K	TD	TL	UT
8	9/16	1.375	1 3/8	11 1/4
10	11/16	1.750	1 3/4	14 1/8
12	11/16	1.750	1 3/4	16 1/4
14	3/4	2.000	2	18 3/4

BORE	ROD (MM)	KK SM	A	B	V	W	Y	ADD LB	STROKE P	XJ
8	1 3/8	1-14	1 5/8	2	1/4	7/8	2 13/16	5 7/8	3 1/4	6
8	1 3/4	1 1/4-12	2	2.375	3/8	1 1/8	3 1/16	5 7/8	3 1/4	6 1/4
8	2	1 1/2-12	2 1/4	2.625	3/8	1 1/4	3 3/16	5 7/8	3 1/4	6 3/8
8	2 1/2	1 7/8-12	3	3.125	1/2	1 1/2	3 7/16	5 7/8	3 1/4	6 5/8
10	1 3/4	1 1/4-12	2	2.375	3/8	1 1/8	3 1/8	7 1/8	4 1/8	7 1/4
10	2	1 1/2-12	2 1/4	2.625	3/8	1 1/4	3 1/4	7 1/8	4 1/8	7 3/8
10	2 1/2	1 7/8-12	3	3.125	1/2	1 1/2	3 1/2	7 1/8	4 1/8	7 5/8
12	2	1 1/2-12	2 1/4	2.625	3/8	1 1/4	3 1/4	7 5/8	4 5/8	7 7/8
12	2 1/2	1 7/8-12	3	3.125	1/2	1 1/2	3 1/2	7 5/8	4 5/8	8 1/8
12	3	2 1/4-12	3 1/2	3.75	1/2	1 1/2	3 1/2	7 5/8	4 5/8	8 1/8
14	2 1/2	1 7/8-12	3	3.125	1/2	1 1/2	3 13/16	8 7/8	5 1/2	9 1/4
14	3	2 1/4-12	3 1/2	3.75	1/2	1 1/2	3 13/16	8 7/8	5 1/2	9 1/4
14	3 1/2	2 1/2-12	3 1/2	4.25	1/2	1 1/2	3 13/16	8 7/8	5 1/2	9 1/4

**MT4 $\varnothing 8'' \sim 14''$
WITH CENTER TRUNNION**

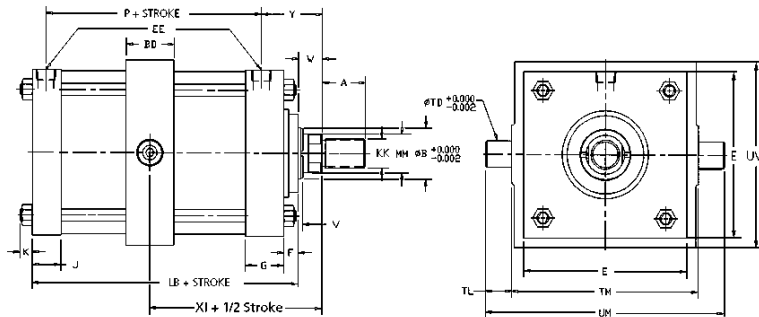

BORE	BD	E	EE(NPT)	F	G
8	2 1/2	8 1/2	3/4	3/4	2
10	3	10 5/8	1	3/4	2 1/4
12	3	12 3/4	1	3/4	2 1/4
14	3 1/2	14 3/4	1 1/4	3/4	2 3/4

BORE	ROD (MM)	KK SM	A	B	V	W	Y	ADD STROKE/2 XI
8	1 3/8	1-14	1 5/8	2	1/4	7/8	2 13/16	4.438
8	1 3/4	1 1/4-12	2	2.375	3/8	1 1/8	3 1/16	4.688
8	2	1 1/2-12	2 1/4	2.625	3/8	1 1/4	3 3/16	4.813
8	2 1/2	1 7/8-12	3	3.125	1/2	1 1/2	3 7/16	5.063
10	1 3/4	1 1/4-12	2	2.375	3/8	1 1/8	3 1/8	5.188
10	2	1 1/2-12	2 1/4	2.625	3/8	1 1/4	3 1/4	5.313
10	2 1/2	1 7/8-12	3	3.125	1/2	1 1/2	3 1/2	5.563
12	2	1 1/2-12	2 1/4	2.625	3/8	1 1/4	3 1/4	5.563
12	2 1/2	1 7/8-12	3	3.125	1/2	1 1/2	3 1/2	5.813
12	3	2 1/4-12	3 1/2	3.75	1/2	1 1/2	3 1/2	5.813
14	2 1/2	1 7/8-12	3	3.125	1/2	1 1/2	3 13/16	6.563
14	3	2 1/4-12	3 1/2	3.75	1/2	1 1/2	3 13/16	6.563
14	3 1/2	2 1/2-12	3 1/2	4.125	1/2	1 1/2	3 13/16	6.563

BORE	J	K	TD	TL	TM
8	1 1/2	9/16	1.375	1 3/8	9 3/4
10	2	11/16	1.750	1 3/4	12
12	2	11/16	1.750	1 3/4	14
14	2 1/4	3/4	2.000	2	16 1/4

BORE	UM	UV	ADD LB	STROKE P
8	12 1/2	9 1/2	5 7/8	3 1/4
10	15 1/2	11 3/4	7 1/8	4 1/8
12	17 1/2	13 3/4	7 5/8	4 5/8
14	20 1/4	16	8 7/8	5 1/2

MX1/MX2/MX3 $\varnothing 8'' \sim 14''$
WITH EXTENDED TIE-RODS

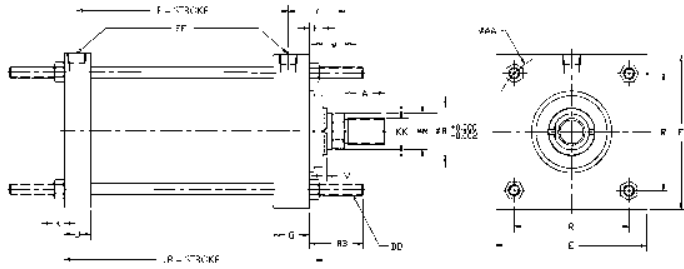

BORE	ROD (MM)	KK SM	A	B	V	W	Y
8	1 3/8	1-14	1 5/8	2	1/4	7/8	2 13/16
8	1 3/4	1 1/4-12	2	2.375	3/8	1 1/8	3 1/16
8	2	1 1/2-12	2 1/4	2.625	3/8	1 1/4	3 3/16
8	2 1/2	1 7/8-12	3	3.125	1/2	1 1/2	3 7/16
10	1 3/4	1 1/4-12	2	2.375	3/8	1 1/8	3 1/8
10	2	1 1/2-12	2 1/4	2.625	3/8	1 1/4	3 1/4
10	2 1/2	1 7/8-12	3	3.125	1/2	1 1/2	3 1/2
12	2	1 1/2-12	2 1/4	2.625	3/8	1 1/4	3 1/4
12	2 1/2	1 7/8-12	3	3.125	1/2	1 1/2	3 1/2
12	3	2 1/4-12	3 1/2	3.75	1/2	1 1/2	3 1/2
14	2 1/2	1 7/8-12	3	3.125	1/2	1 1/2	3 13/16
14	3	2 1/4-12	3 1/2	3.75	1/2	1 1/2	3 13/16
14	3 1/2	2 1/2-12	3 1/2	4.25	1/2	1 1/2	3 13/16

BORE	AA	BB	DD	E	EE(NPT)	F	G	J	K	R	Add LB	STROKE P
8	9.1	2 5/16	5/8-18	8 1/2	3/4	3/4	2	1 1/2	9/16	6.44	5 7/8	3 1/4
10	11.2	2 11/16	3/4-16	10 5/8	1	3/4	2 1/4	11/16	7.92	7.92	7 1/8	4 1/8
12	13.3	2 11/16	3/4-16	12 3/4	1	3/4	2 1/4	2	11/16	9.40	7 5/8	4 5/8
14	15.4	3 3/16	7/8-14	14 3/4	1 1/4	3/4	2 3/4	2 1/4	3/4	10.90	8 7/8	5 1/2

NCA1W $\varnothing 1.5'' \sim 6''$
DOUBLE ROD

BORE	ROD \varnothing MM	KK SM	A	B	V	W	Y	Add LD	STROKE P
1 1/2	5/8	7/16-20	3/4	1.125	1/4	5/8	1 15/16	5	2 3/8
1 1/2	1	3/4-16	1 1/8	1.5	1/2	1	2 5/16	5	2 3/8
2	5/8	7/16-20	3/4	1.125	1/4	5/8	1 15/16	5	2 3/8
2	1	3/4-16	1 1/8	1.5	1/2	1	2 5/16	5	2 3/8
2	1 3/8	1-14	1 5/8	2	5/8	1 1/4	2 9/16	5	2 3/8
2 1/2	5/8	7/16-20	3/4	1.125	1/4	5/8	1 15/16	5	2 3/8
2 1/2	1	3/4-16	1 1/8	1.5	1/2	1	2 5/16	5	2 3/8
2 1/2	1 3/8	1-14	1 5/8	2	5/8	1 1/4	2 9/16	5	2 3/8
3 1/4	1	3/4-16	1 1/8	1.5	1/4	3/4	2 3/8	5 7/8	2 5/8
3 1/4	1 3/8	1-14	1 5/8	2	3/8	1	2 5/8	5 7/8	2 5/8
4	1	3/4-16	1 1/8	1.5	1/4	3/4	2 3/8	5 7/8	2 5/8
4	1 3/8	1-14	1 5/8	2	3/8	1	2 5/8	5 7/8	2 5/8
5	1	3/4-16	1 1/8	1.5	1/4	3/4	2 5/16	5 7/8	2 3/4
5	1 3/8	1-14	1 5/8	2	3/8	1	2 9/16	5 7/8	2 3/4
5	1 3/4	1 1/4-12	2	2.375	1/2	1 1/4	2 13/16	5 7/8	2 3/4
6	1 3/8	1-14	1 5/8	2	1/4	7/8	2 13/16	6 7/8	3
6	1 3/4	1 1/4-12	2	2.375	3/8	1 1/8	3 1/16	6 7/8	3
6	2	1 1/2-12	2 1/4	2.625	3/8	1 1/4	3 3/16	6 7/8	3

BORE	E	EE(NPT)	F	G	J	K
1 1/2	2	3/8	3/8	2	1	1/4
2	2 1/2	3/8	3/8	2	1	5/16
2 1/2	3	3/8	3/8	2	1 1/8	5/16
3 1/4	3 3/4	1/2	5/8	2 1/4	1 1/4	3/8
4	4 1/2	1/2	5/8	2 1/4	1 1/4	3/8
5	5 1/2	1/2	5/8	2 1/4	1 1/2	7/16
6	6 1/2	3/4	3/4	2 3/4	1 5/8	7/16

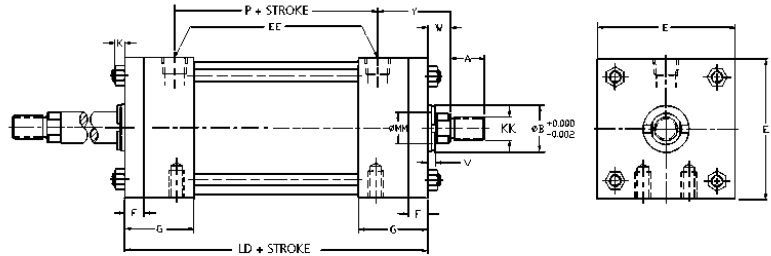

NCA1W $\varnothing 8'' \sim 14''$
DOUBLE ROD

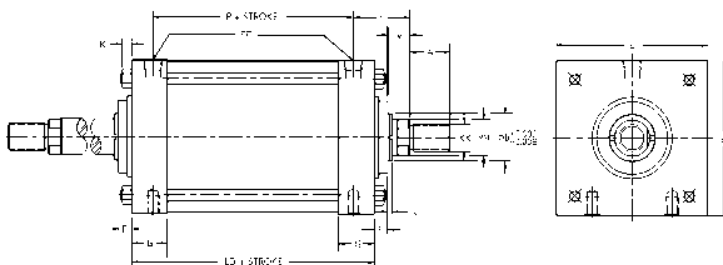

BORE	E	EE(NPT)	F	G	J	K	Add LD	STROKE P
8	8 1/2	3/4	3/4	2	1 1/2	9/16	7 1/8	3 1/4
10	10 5/8	1	3/4	2 1/4	2	11/16	8 1/8	4 1/8
12	12 3/4	1	3/4	2 1/4	2	11/16	8 5/8	4 5/8
14	14 3/4	1 1/4	3/4	2 3/4	2 1/4	3/4	10 1/8	5 1/2

BORE	ROD (MM)	KK SM	A	B	V	W	Y
8	1 3/8	1-14	1 5/8	2	1/4	7/8	2 13/16
8	1 3/4	1 1/4-12	2	2.375	3/8	1 1/8	3 1/16
8	2	1 1/2-12	2 1/4	2.625	3/8	1 1/4	3 3/16
8	2 1/2	1 7/8-12	3	3.125	1/2	1 1/2	3 7/16
10	1 3/4	1 1/4-12	2	2.375	3/8	1 1/8	3 1/8
10	2	1 1/2-12	2 1/4	2.625	3/8	1 1/4	3 1/4
10	2 1/2	1 7/8-12	3	3.125	1/2	1 1/2	3 1/2
12	2	1 1/2-12	2 1/4	2.625	3/8	1 1/4	3 1/4
12	2 1/2	1 7/8-12	3	3.125	1/2	1 1/2	3 1/2
12	3	2 1/4-12	3 1/2	3.75	1/2	1 1/2	3 1/2
14	2 1/2	1 7/8-12	3	3.125	1/2	1 1/2	3 13/16
14	3	2 1/4-12	3 1/2	3.75	1/2	1 1/2	3 13/16
14	3 1/2	2 1/2-12	3 1/2	4.75	1/2	1 1/2	3 13/16

TECHNICAL SPECIFICATIONS

CYLINDER BORES AND FORCES: PUSH STROKE

Bore (in)	Piston Area (in)	Forces (lbs); Push Stroke Operating medium Pressure (PSI)					
		50	60	80	100	200	250
1.5	1.767	88	106	141	177	353	442
2	3.142	157	188	251	314	628	785
2.5	4.909	245	295	393	491	982	1227
3.25	8.296	415	498	664	830	1659	2074
4	12.566	628	754	1005	1257	2513	3142
5	19.635	982	1178	1571	1964	3927	4909
6	28.274	1414	1696	2262	2827	5655	7069
7	38.485	1924	2309	3079	3848	7697	9621
8	50.266	2513	3016	4021	5027	10053	12566
10	78.540	3927	4712	6283	7854	15708	19635
12	113.098	5655	6786	9048	11310	22620	28274
14	153.938	7697	9236	12315	15394	30788	38485

To calculate thrust forces not shown in the table, multiply operating pressure by piston area.

HOW TO USE THIS TABLE

- 1 Locate column with desired operating pressure.
- 2 Move down that column and locate the thrust value which is equal (or the next larger to the force to be delivered by the cylinder.)
- 3 On that same line, locate in the first (left) column the bore size recommended for your application.

Note: These are guide lines only which must be substantiated using additional data specific to your application.

CYLINDER BORES AND FORCES: PULL STROKE

Piston Rod Diameter (in)	Piston Rod Area (in)	Forces (lbs); Pull Stroke (Deduct the listed thrusts corresponding to the rod size from push stroke pressure) Operating medium Pressure (PSI)					
		50	60	80	100	200	250
0.625	0.307	15	18	25	31	61	77
1	0.785	39	47	63	79	157	196
1.375	1.485	74	89	119	148	297	371
1.75	2.405	120	144	192	241	481	601
2	3.142	157	188	251	314	628	785
2.5	4.909	245	295	393	491	982	1227
3	7.069	353	424	565	707	1414	1767
3.5	9.621	481	577	770	962	1924	2405
4	12.566	628	754	1005	1257	2513	3142

To calculate pull forces not shown in the table, use the following formula:

Pull Force = (Piston Area-Rod Area) x Working Pressure

HOW TO USE THIS TABLE

- 1 To find the force on the pull stroke, locate the required piston rod diameter in the left most column.
- 2 Moving to the right, locate the required working pressure
- 3 Deduct the value shown at the intersection from the push stroke force value determined from the Push Stroke table. The resultant is the available pull stroke table.

OVERSIZE PISTON RODS

- Selection Table -

Thrust In lbs	Piston Rod Diameter							
	5/8"	1"	1 3/8"	1 3/4"	2"	2 1/2"	3"	3 1/2"
400	37	83	134	186				
700	30	68	118	168	202	275		
1000	27	60	105	155	190	257	330	
1400	24	53	92	142	174	244	308	385
1800	23	48	82	127	160	230	296	366
2400	19	45	75	114	145	213	281	347
3200	16	41	67	103	130	194	261	329
4000	13	38	63	94	119	175	240	310
5000	9	34	60	87	110	163	225	289
6000	5	30	56	82	102	152	208	274
8000	4	26	50	76	93	137	188	245
10000	3	21	45	70	89	125	172	222
12000		17	41	65	84	118	155	210
16000		9	34	57	75	110	142	188
20000		8	28	52	68	103	136	172
30000		5	12	39	55	87	120	156
40000			11	22	43	74	108	142
50000			9	15	30	66	96	130
60000				14	18	57	88	119
80000				12	16	36	71	104
100000					14	22	57	90
120000					12	21	45	77
140000						19	27	64
160000						17	26	47
200000						14	23	31
250000							19	28
300000								25
350000								22
400000								19

Oversized Piston Rods





In applications where extra column strength is required, or for long push stroke cylinders, oversized piston rods may be required.

It must be noted, however, that oversized piston rods transmit more side load than is the case with more flexible smaller rods; therefore, the use of oversized rods should not be considered a remedy against excessive side loads.

HOW TO USE THIS TABLE

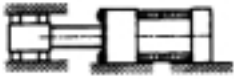
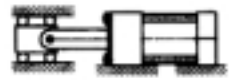
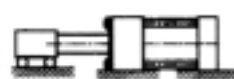
- 1 From Stroke Factors Table (see Table 1 on page 21), determine the value of L.
- 2 In the left table, locate the previously determined thrust value.
- 3 Moving across the table, locate dimension L (If the exact length is not shown, select the next larger value)

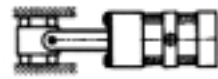
**STROKE FACTORS
FOR VARIOUS MOUNTING STYLES
TABLE 1**

Cylinder Mounting	Rod End Connection		Stroke Factor
Side-Tapped, Head or Cap Flange, Tie-Rod, Center or Side Lug	Fixed and Rigidly Guided		.50
Side-Tapped, Head or Cap Flange, Tie-Rod, Center or Side Lug	Pivot and Rigidly Guided		.70
Side-Tapped, Head or Cap Flange, Tie-Rod, Center or Side Lug	Supported but not Rigidly Guided		2.00
Side-Tapped, Head or Cap Flange, Tie-Rod, Center or Side Lug	None		5.00
Head Trunnion	Pivoted and Rigidly Guided		1.00
Center Trunnion	Pivoted and Rigidly Guided		1.50
Cap Trunnion or Clevis	Pivoted and Rigidly Guided		2.00

**STOP TUBE
REQUIREMENTS / TABLE 2**

L (in)	Tube Length (in)
0-40	0
41-50	1
51-60	2
61-70	3
71-80	4
81-90	5
91-100	6
101-110	7
111-120	8
121-130	9
131-140	10
141-150	11
151-160	12
161-170	13
171-180	14
181-190	15
181-190	16
191-200	17
201-220	18
221-230	19
231-240	20
241-250	21
251-260	22
261-270	23
271-280	24
281-290	25
291-300	26
301-310	27

Stop Tubes are used for reducing piston and bearing loads on to prevent buckling and jack-knifing of horizontally installed long push stroke cylinders when the piston rod is fully extended.

How to use this table

- 1 Multiply Cylinder Stroke by Stroke Factor for appropriate mounting style to obtain Effective Length L.
- 2 If Cylinder has extra rod extension, add length of extension to stroke length prior to obtaining Effective Length L.

Example:
NCCA1L800-6000-XTATCDN
8" Bore
60" Stroke
MS1 Mount
Supported but not rigidly guided

1) From Table 1, determine Stroke Factor (SF) –
Stroke Factor 2.0

2) Determine Effective Length L
L = Stroke x Stroke Factor
= 60 x 2.0
= 120 inches

3) From Table 2, determine Stop Tube Requirements –
Find L length and note Stop Tube length
Stop Tube Length = 8"

OPTIONS
MOUNTING
BRACKETS FOR
SWITCHES

MODEL	BORE SIZE
BT-12	500 (5" Bore)
	600 (6" Bore)
BT-18A	800 (8" Bore)
BT-20	1000 (10" Bore)
	1200 (12" Bore)

OPTIONS
AUTO SWITCHES - REED
TYPE

MODEL NUMBER	OPERATING VOLTAGE	MAX CURRENT OR OPERATING CURRENT RANGE (mA)	INDICATOR LIGHT / WIRE OUTPUT
D-A53	24VDC	5-20mA	Yes
D-A54	24VDC	5-20mA	Yes
	100VAC	5-25mA	
	200VAC	5-12.5mA	
D-A56	4-8VDC	20mA	Yes
D-A59W	24VDC	5-40mA	Yes
D-A64	24VAC/DC	50mA	-
	100VAC	25mA	
	200VAC	12.5mA	
D-A67	24VDC	30mA	-

OPTIONS
AUTO SWITCHES - SOLID STATE TYPE

MODEL NUMBER	OPERATING VOLTAGE	MAX CURRENT OR OPERATING CURRENT RANGE (mA)	INDICATOR LIGHT / WIRE OUTPUT
D-F59	28VDC OR LESS	150mA	3 WIRE (NPN)
D-F5P	-	100mA	3 WIRE (PNP)
D-J59	24VDC	5-150mA	2 WIRE
	(10-28VDC)		
D-F59W	28VDC	80mA	3 WIRE (NPN)
D-F59PW	-	80mA	3 WIRE (PNP)
D-J59W	24VDC	5-40mA	2 WIRE
	(10-28VDC)		
D-F5BAL	24VDC	5-40mA	2 WIRE (NPN)
	(10-28VDC)		
D-F59F	28VDC	40mA	4 WIRE (NPN)
D-F5NTL	28VDC	80mA	3 WIRE (NPN)

THREAD FORM
CODE
SPECIAL ROD THREAD - XA
OPTION

IMPERIAL

Code	: Thread Form
00	: None (No reduction in piston rod diameter)
01	: 2-56
02	: 2-64
03	: 4-40
04	: 4-48
05	: 5-40
06	: 5-44
07	: 6-32
08	: 6-40
09	: 8-32
10	: 8-36
11	: 10-24
12	: 10-32
13	: 1/4-20
14	: 1/4-28
15	: 5/16-18
16	: 5/16-24
17	: 3/8-16
18	: 3/8-24
19	: 7/16-14
20	: 7/16-20
21	: 1/2-13
22	: 1/2-20
23	: 9/16-12
24	: 9/16-18
25	: 5/8-11
26	: 5/8-18

NCA1 (Mounting) (Bore) - (Stroke) (Suffix) (Auto Switch) - XA 27 M

Thread Form Code

M Male Rod End
F Female Rod End
B No Thread

METRIC

Code	: Thread Form
27	: 3/4-10
28	: 3/4-16
29	: 7/8-9
30	: 7/8-14
31	: 1-8
32	: 1-12
33	: 1 1/8-7
34	: 1 1/8-12
35	: 1 1/4-7
36	: 1 1/4-12
37	: 1 3/8-6
38	: 1 3/8-12
39	: 1-14
40	: 1 1/2-16
41	: 1 1/2-12
42	: 12-24
43	: 3/8-20
44	: 2 1/2-12
45	: 2-12
46	: 2 1/4-12
47	: 1 7/8-12
48	: 2 3/4-12
49	: 3-12
50	: 3 1/4-12
51	: 3 1/2-12
52	: 1 3/4-12
53	: 1 3/4-5
54	: 1 7/8-12

METRIC

Code	: Thread Form
60	: M3 x 0.35
61	: M3 x 0.5
62	: M4 x 0.5
63	: M4 x 0.7
64	: M5 x 0.5
65	: M5 x 0.8
66	: M6 x 0.75
67	: M6 x 1.0
68	: M8 x 1.0
69	: M8 x 1.25
70	: M10 x 1.25
71	: M10 x 1.5
72	: M12 x 1.5
73	: M12 x 1.75
74	: M14 x 1.75
75	: M14 x 2.0
76	: M16 x 1.5
77	: M16 x 2.0
78	: M18 x 1.5
79	: M18 x 2.5
80	: M20 x 2.0
81	: M20 x 2.5
82	: M22 x 1.5
83	: M22 x 2.5
84	: M24 x 2.0
85	: M24 x 1.5
86	: M26 x 1.5
87	: M30 x 1.5

METRIC

Code	: Thread Form
88	: M14 x 1.5
89	: M20 x 1.5
90	: M12 x 1.25
91	: M42 x 1.5
92	: M24 x 3.0
93	: M30 x 3.5
94	: M36 x 4.0
95	: M16 x 1.25
96	: M36 x 1.5
97	: M36 x 2.0

This chart represents all current thread codes and are not all applicable to NCA1 due to rod size limitations. Male threads cannot be specified equal to, but not, greater than the rod diameters as standard.

BORE (INCH)	MM	KK	A	B	C	WF
150 (1.5")	5/8	7/16-20	3/4	1 1/8	3/8	1
200 (2")	5/8	7/16-20	3/4	1 1/8	3/8	1
250 (2.5")	5/8	7/16-20	3/4	1 1/8	3/8	1
325 (3.25")	1	3/4-20	1 1/8	1 1/2	1/2	1 3/8
400 (4")	1	3/4-20	1 1/8	1 1/2	1/2	1 3/8

FEMALE ROD DIAMETER

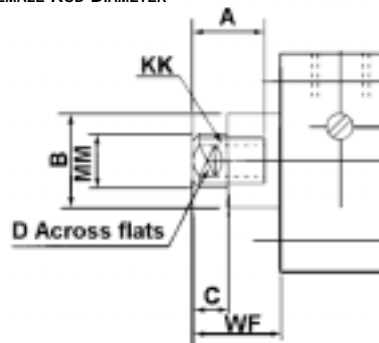

PARTS BREAKDOWN

OPTIONS
SERIES NCA1 - XC3 OPTION

NCDA1L500 - 2400 - XC3 **A B E F** TAT

- Head Cover Port Location A, B, C or D •
- Head Cover Cushion Location A, B, C or D •
- Cap Cover Port Location E, F, G or H •
- Cap Cover Cushion Location E, F, G or H •

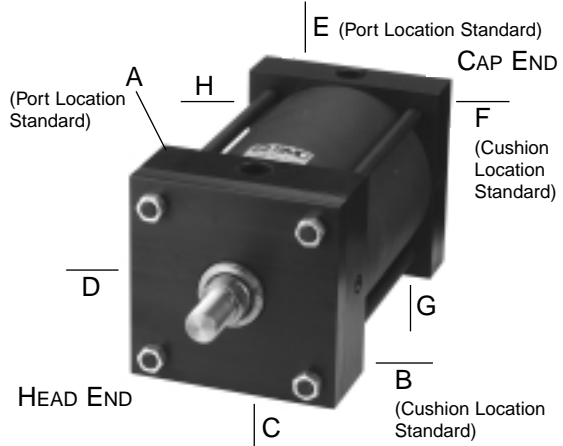

**CHART 1
Spare Parts and Repair Kit**

Item	Quantity	Description
11	1	Head
12	1	Cap
13	1	Barrel
14*	2	Barrel Seal
15	4	Tie Rods
16	4	Tie Rod Nuts
21	1	Piston (See Note1)
22	1	Piston Rod (See Note1)
24*	2	Piston Packings
26A	1	Piston Rod Assembly (See Note1)
28	1	Wear Band
31	1	Gland Bushing
32*	1	Gland Packing
33*	1	Gland Packing Backup
34*	1	Gland Seal
35*	1	Gland Seal Backup
41*	1	Rod Wiper
44	1	Magnet
51*	2	Cushion Packing
52	2	Cushion Backup
53	2	Cushion Spring
54	2	Cushion Retainer
55*	2	Adjustable Cushion Assembly
67	1	Cushion Seat
87	1	Head Flange

* Denotes 'Included in Service Kit'
Note 1) Piston Rod and Piston are not sold separately.
Please order Item No 26A Piston Rod Assembly.

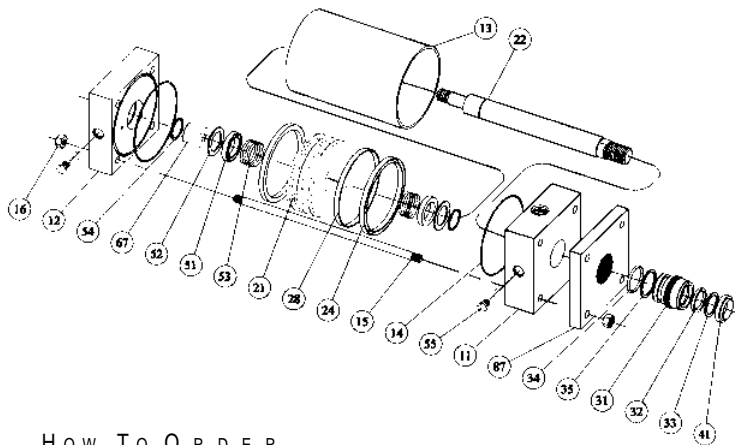

**HOW TO ORDER
SERIES NCA1 REPLACEMENT
PARTS**

NCDA1 - - - - -

MAGNET (if applicable) —

MOUNTING STYLE —

Item No from CHART 1 to reference Part required —

CONSTRUCTION DETAILS

- XTATAluminum Tube
- XTSTSteel Tube Construction
- XTSSStainless Steel Construction
- XTSCT.....Steel w/ composite tube
- XTACT ...Composite tube
- XTSSCT...Stainless steel w/ composite tube

STROKE

Only necessary for Item No 13, 15 and 26A

BORE SIZE	ROD Ø	ROD THREAD Ø
1501.5"	5/8"	7/16-20
2002"	5/8"	7/16-20
2502.5"	5/8"	7/16-20
3253.25"	1"	3/4-16
4004"	1"	3/4-16
5005"	1"	3/4-16
6006"	1-3/8"	1-14
8008"	1-3/8"	1-14
1000.....10"	1-3/4"	1 1/4-12
1200.....12"	2"	1 1/2-12
1400.....14"	2-1/2"	1 7/8-12

REFER TO PAGE 22 FOR OPTIONAL ROD THREADS

**HOW TO ORDER
SERIES NCA1 SEAL KIT**

NCA1- - - **PS** -

STYLE —

- ...Single Rod
- W ...Double Rod

OPTIONS (IF APPLICABLE)

XB5

- T G 1 3/8"
- H 1 3/4"
- J 2"
- K 2 1/2"
- L 3"
- M 3 1/2"

XB6 HIGH TEMPERATURE

For information on Bore Size, Rod ø and Rod Thread ø, please see **How To Order Series NCA1 Replacement Parts.**

ACCESSORIES

Eye Brackets

Part No	CB	CD	DD	E	F	FL	LR	M	MR	R
NCA1-P150	3/4	1/2	13/32	2 1/2	3/8	1 1/8	3/4	1/2	9/16	1.63
NCA1-P325	1 1/4	3/4	17/32	3 1/2	5/8	1 7/8	1 1/4	3/4	7/8	2.56
NCA1-P800	1 1/2	1	21/32	4 1/2	3/4	2 1/4	1 1/2	1	1 1/4	3.25
NCA1-P1000	2	1 3/8	21/32	5	7/8	3	2 1/8	1 3/8	1 5/8	3.81
NCA1-P1200	2 1/2	1 3/4	29/32	6 1/2	7/8	3 1/8	2 1/4	1 3/4	2 1/8	4.95
NCA1-P1400	2 1/2	2	1 1/16	7 1/2	1	3 1/2	2 1/2	2	2 7/16	5.75
NCA1-P1401	3	2 1/2	1 3/16	8 1/2	1 3/4	4 3/4		2 1/2	3	6.58
NCA1-P1402	3	3	1 5/16	9 1/2	2	5 1/4		2 3/4	3 1/4	7.50

Note) Pivot Pin not included

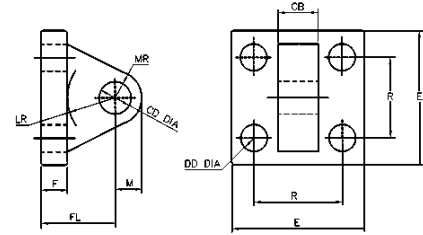

Clevis Brackets

Part No	AA	BA	CB	CD	CW	DD	E	F	FL	LR	M	MR
NCA1-CB150	2.3	1 5/8	0.785	1/2	1/2	3/8 -24	2 1/2	3/8	1 1/8	1/2	1/2	9/16
NCA1-CB325	3.6	2 9/16	1.265	3/4	5/8	1/2 -20	3 1/2	5/8	1 7/8	1 1/16	3/4	1 1/16
NCA1-CB800	4.6	3 1/4	1.515	1	3/4	5/8 -18	4 1/2	3/4	2 1/4	1 1/4	1	1 1/8
NCA1-CB1000	5.4	3 13/16	2.032	1 3/8	1	5/8 -18	5	7/8	3	1 7/8	1 3/8	1 3/4
NCA1-CB1200	7	4 15/16	2.531	1 3/4	1 1/4	7/8 -14	6 1/2	7/8	3 1/8	2	1 3/4	1 7/8
NCA1-CB1400	8.1	5 3/4	2.531	2	1 1/4	1 -14	7 1/2	1	3 1/2	2 1/8	2	2 1/8
NCA1-CB1401	9.3	6 19/32	3.032	2 1/2	1 1/2	1 1/8-12	8 1/2	1	4	2 5/8	2 1/2	2 1/2
NCA1-CB1402	10.6	7 1/2	3.032	3	1 1/2	1 1/4-12	9 1/2	1	4 1/4	2 7/8	2 3/4	2 3/4

Note) Pivot Pin not included

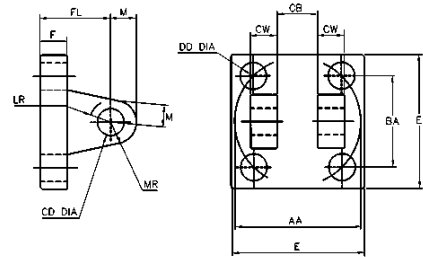

Rod Clevises

Part No	CB	CD	CE	CH	CW	F	L	A	KK	ER
NY-150	0.765	0.5	1 1/2	1	1/2	1	3/4	3/4	7/16-20	1/2
NY-325	1.265	0.75	2 3/8	1 3/8	5/8	1 1/4	1 1/4	1 1/8	3/4-16	3/4
NY-800	1.515	1	3 1/8	1 1/2	3/4	1 1/2	1 1/2	1 5/8	1 -14	1
NY-1000	2.032	1 3/8	4 1/8	2	1	2	2 1/8	2	1 1/4 -12	1 3/8
NY-1200	2.531	1 3/4	4 1/2	2 3/8	1 1/4	2 3/8	2 1/4	2 1/4	1 1/2 -12	1 3/4
NY-1400	2.531	2	5 1/2	2 15/16	1 1/4	2 15/16	2 1/2	3	1 7/8 -12	2
NY-1401	3.032	2 1/2	6 1/2	3 1/2	1 1/2	3 1/2	3	3 1/2	2 1/4 -12	2 1/2
NY-1402	3.032	3	6 3/4	3 7/8	1 1/2	3 7/8	3 1/4	3 1/2	2 1/2 -12	2 3/4

Note) Pivot Pin not included

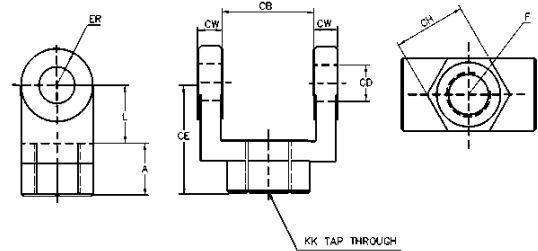

Order to match Rod Thread

Rod Eyes

Part No	A	CA	CB	CD	ER	KK
NI-150	3/4	1 1/2	3/4	1/2	5/8	7/16 20
NI-325	1 1/8	2 1/16	1 1/4	3/4	7/8	3/4 -16
NI-800	1 5/8	2 13/16	1 1/2	1	1 3/16	1 -14
NI-1000	2	3 7/16	2	1 3/8	1 9/16	1 1/4 -12
NI-1200	2 1/4	4	2 1/2	1 3/4	2	1 1/2 -12
NI-1400	3	5	2 1/2	2	2 1/2	1 7/8 -12
NI-1401	3 1/2	5 13/16	3	2 1/2	2 13/16	2 1/4 -12
NI-1402	3 1/2	6 1/8	3	3	3 1/4	2 1/2 -12

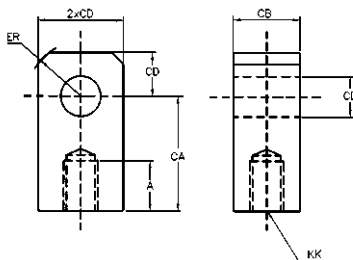

Pivot Pin

Part No	CD	CL
NCA1-150	1/2	1 7/8
NCA1-325	3/4	2 5/8
NCA1-800	1	3 1/8
NCA1-1000	1 3/8	4 1/8
NCA1-1200	1 3/4	5 1/8
NCA1-1400	2	5 1/8
NCA1-1401	2.5	6.19
NCA1-1402	3	6.25

Note) Retainer Rings are included

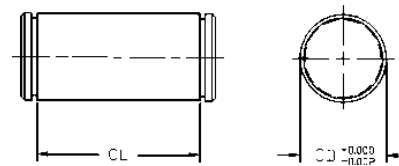

ALIGNMENT COUPLERS

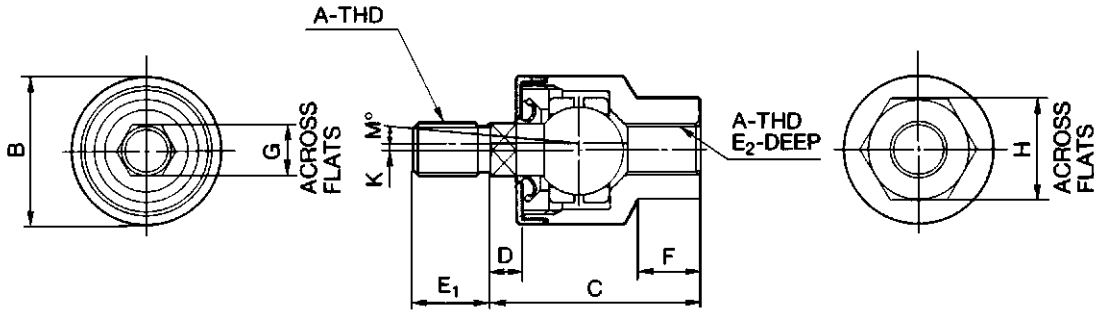

Part No	A	B	C	D	E1	E2	F	G	H	K	M°
NJ-07	7/16-20	1.22	1.83	0.31	0.75	0.75	0.63	0.44	0.75	0.03	5°
NJ-08	1/2-20	1.61	2.11	0.31	0.75	0.75	0.63	0.5	1	0.06	5°
NJ-12	3/4-16	1.97	2.91	0.5	1.13	1.13	0.94	0.81	1.13	0.06	5°

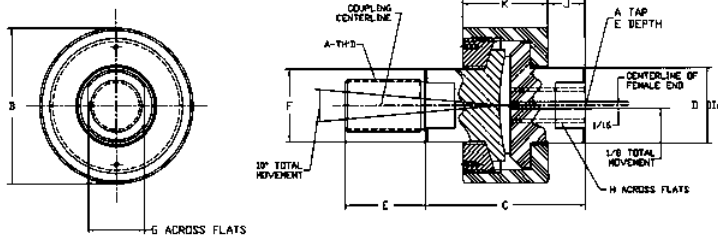

Part No	A	B	C	D	E	F	G	H	J	K
NCA1-AC800	1-14	2 3/4	3 1/16	1 1/2	1 5/8	1 1/4	1 1/8	1 1/4	9/16	2
NCA1-AC1000	1 1/4-12	3 1/2	4	2	2	1 1/2	1 1/4	1 11/16	3/4	2 1/2
NCA1-AC1200	1 1/2-12	4	4 3/8	2 1/4	2 1/4	1 3/4	1 1/2	1 15/16	7/8	2 3/4
NCA1-AC1400	1 7/8-12	5	5 5/8	3	3	2 1/4	1 15/16	2 5/8	1 3/8	3 3/8
NCA1-AC1401	2 1/4-12	6 3/4	6 3/8	3 1/4	3 1/2	2 3/4	2 3/8	2 7/8	1 5/8	3 3/4
NCA1-AC1402	2 1/2-12	7	6 1/2	4	3 1/2	3 1/4	2 7/8	3 3/8	1 5/8	3 7/8

Rod Jam Nut

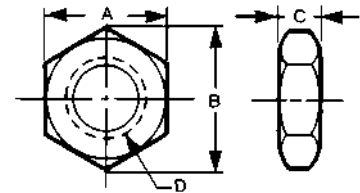

Part No	A Across Flats	B Across Corners (max)	C (max)	D (max)
JM-045	0.69	0.79	0.26	7/16-20UNF
JM-10	1.12	1.30	0.42	3/4-16UNF
JM-800	1.62	1.73	0.57	1-14UNF
JM-1000	2.00	2.16	0.75	1 1/4-12UNF
JM-1200	2.37	2.50	0.88	1 1/2-12UNF
JM-1400	2.93	3.39	1.07	1 7/8-12UNF
JM-1401	3.50	4.04	1.25	2 1/4-12
JM-1402	3.87	4.47	1.50	2 1/2-12UNF

Limited Cylinder Warranty - Terms and Conditions of Sale....

SMC warrants that for 18 months or 1800 service miles*, whichever occurs first from date of purchase, it will replace or make adjustment at SMC's option, of any defective cylinder sold if the cylinder product is returned with SMC's prior written consent, transportation prepaid by the original buyer, and received by SMC at its place of business within the warranty period.

SMC shall have the right to inspect, prior to return, at the buyer's facility, any products claimed to be defective.

This warranty is limited exclusively to cylinder products which, in the opinion of SMC, have not been subjected to modification, misuse, negligence, misapplication, repairs or alterations. Damage caused by fire, theft, riot, explosion or acts of Gods are excluded

from this warranty. The foregoing constitutes the sole exclusive remedy of the buyer and the only liability of SMC and is in lieu of any and all other warranties, expressed or implied, or statutory as to merchantability, fitness for purpose sold, description, quality, productiveness or any other matter. SMC shall not be liable for loss of use, or profit, or special or consequential damages.

SMC assumes no responsibility for engineering technical advice pertaining to any manufactured item to which SMC's products or goods have been attached. No agent, employee, distributor, or representative of SMC has the authority to extend the scope of this warranty or to make any other promises, warranties or guarantees concerning the manufacture, sale or application of SMC's products.

*Service Miles = (inches/stroke) x (2 strokes/cycle) x (no of cycles) x [1 mile / 63,360 inches]

Published by THE MARKETING DEPARTMENT OF SMC PNEUMATICS (CANADA) LTD.
 6768 FINANCIAL DRIVE, MISSISSAUGA, ONTARIO L5N 7J6 CANADA
 TEL: (905) 812 0400
 FAX: (905) 812 8686

Whereas SMC Pneumatics (Canada) Ltd. has, at the time of publishing, made all reasonable efforts to ensure the accuracy of the information detailed in this catalog; SMC can in no way warrant the information herein contained.

World Wide SMC Support...

United States Branch Offices For a branch office near you call: 1-800-SMC-SMC1 (762-7621)

SMC Corporation of America (Atlanta)
1440 Lakes Parkway, Suite 600
Lawrenceville, GA 30043
TEL: (770) 624-1940
FAX: (770) 624-1943

SMC Corporation of America (Austin)
9101 Wall Street, Suite 1030
Austin, TX 78754
TEL: (512) 926-2646
FAX: (512) 926-7055

SMC Corporation of America (Boston)
Zero Centennial Drive
Peabody, MA 01960
TEL: (978) 326-3600
Fax: (978) 326-3700

SMC Corporation of America (Charlotte)
5029-B West W.T. Harris Blvd.
Charlotte, NC 28269
TEL: (704) 597-9292
FAX: (704) 596-9561

SMC Corporation of America (Chicago)
27725 Diehl Road
Warrenville, IL 60555
Tel: (630) 393-0080
FAX: (630) 393-0084

SMC Corporation of America (Cincinnati)
4598 Olympic Blvd.
Erlanger, KY 41018
TEL: (859) 647-5600
FAX: (859) 647-5609

SMC Corporation of America (Cleveland)
2305 East Aurora Rd., Unit A-3
Twinsburg, OH 44087
TEL: (330) 963-2727
FAX: (330) 963-2730

SMC Corporation of America (Dallas)
1301 W. Beltline Suite 119
Carrollton, TX 75006
TEL: (972) 446-9554
FAX: (972) 446-5931

SMC Corporation of America (Detroit)
2990 Technology Drive
Rochester Hills, MI 48309
TEL: (248) 299-0202
FAX: (248) 293-3333

SMC Corporation of America (Houston)
9001 Jameel, Suite 180
Houston, TX 77040
TEL: (713) 460-0762
FAX: (713) 460-1510

SMC Corporation of America (L.A.)
14191 Myford Road
Tustin, CA 92780
TEL: (714) 669-1701
FAX: (714) 669-1715

SMC Corporation of America (Milwaukee)
16850 W. Victor Road
New Berlin, WI 53151
TEL: (262) 827-0080
FAX: (262) 827-0092

SMC Corporation of America (Mnpls.)
6541 City West Parkway
Eden Prairie, MN 55344
TEL: (952) 943-1299
FAX: (952) 943-1614

SMC Corporation of America (Nashville)
5000 Linbar Drive, Suite 297
Nashville, TN 37211
TEL: (615) 331-0020
FAX: (615) 331-9950

SMC Corporation of America (Newark)
3434 US Hwy. 22 West, Ste. 110
Somerville, NJ 08876
TEL: (908) 253-3241
FAX: (908) 253-3452

SMC Corporation of America (Phoenix)
2001 W. Melinda Lane
Phoenix, AZ 85027
TEL: (623) 492-0908
FAX: (623) 492-9493

SMC Corporation of America (Portland)
14107 N.E. Airport Way
Portland, OR 97230
TEL: (503) 252-9299
FAX: (503) 252-9253

SMC Corporation of America (Richmond)
4701 Cox Rd.
Richmond, VA 23060
TEL: (804) 527-0500
FAX: (804) 527-2100

SMC Corporation of America (Rochester)
245 Summit Point Drive
Henrietta, NY 14467
TEL: (716) 321-1300
FAX: (716) 321-1865

SMC Corporation of America (S.F.)
85 Nicholson Lane
San Jose, CA 95134
TEL: (408) 943-9600
FAX: (408) 943-9111

SMC Corporation of America (St. Louis)
4130 Rider Trail North
Earth City, MO 63045
TEL: (314) 209-0080
FAX: (314) 209-0085

SMC Corporation of America (Tampa)
18167 US19 North Suite 150
Clearwater, FL 33764
TEL: (813) 243-8350
FAX: (813) 243-8621

Canadian Branch Offices

SMC Pneumatics (Canada) Ltd. (Toronto)
6768 Financial Drive
Mississauga, ON L5N 7J6
TEL: (905) 812-0400
FAX: (905) 812-8686

SMC Pneumatiques (Canada) Ltd. (Montreal)
8495 Dalton Drive
Township of Mount-Royal, PQ H4T 1V5
TEL: (514) 733-9595
FAX: (514) 733-1771

SMC Pneumatiques (Canada) Ltd. (Quebec)
3260 Rue Watt - Local 112
Ste-Foy, PQ G1X 4T5
TEL: (418) 654-1997
FAX: (418) 654-1998

SMC Pneumatics (Canada) Ltd. (Vancouver)
Annacis Business Park
730 Eaton Way - Unit 2
Delta, BC V3M 6J9
TEL: (604) 517-1646
FAX: (604) 517-1647

SMC Pneumatics (Canada) Ltd. (Windsor)
2870 Jefferson BLVD - Unit 1
Windsor, ON N8T 3L2
TEL: (519) 944-0555
FAX: (519) 944-1870

Europe

ENGLAND
SMC Pneumatics (U.K.) Ltd.

GERMANY
SMC Pneumatik GmbH

ITALY
SMC Italia SpA

FRANCE
SMC Pneumatique SA

HOLLAND
SMC Controls BV

SWEDEN
SMC Pneumatics Sweden AB

SWITZERLAND
SMC Pneumatik AG

AUSTRIA
SMC Pneumatik GmbH

SPAIN
SMC Espana, S.A.

IRELAND
SMC Pneumatics (Ireland) Ltd.

ROMANIA
SMC Pneumatics (Romania) Ltd.

RUSSIA
SMC Pneumatik LLC

NORWAY
SMC Pneumatics Norway A/S

DENMARK/LATVIA/LITHUANIA
SMC Pneumatik A/S

Asia

JAPAN
SMC Corporation

KOREA
SMC Pneumatics Korea Co., Ltd.

CHINA
SMC (China) Co., Ltd.

HONG KONG
SMC Pneumatics (Hong Kong) Ltd.

SINGAPORE
SMC Pneumatics (S.E.A.) Pte. Ltd.

PHILIPPINES
SMC Pneumatics (Philippines), Inc.

MALAYSIA
SMC Pneumatics (S.E.A.) Sdn. Bhd.

TAIWAN
SMC Pneumatics (Taiwan) Co., Ltd.

THAILAND
SMC Thailand Ltd.

INDIA
SMC Pneumatics (India) Pvt., Ltd.

North America

MEXICO
SMC Pneumatics (Mexico) S.A. de C.V.

South America

ARGENTINA
SMC Argentina S.A.

CHILE
SMC Pneumatics (Chile) Ltda.

Oceania

AUSTRALIA
SMC Pneumatics (Australia) Pty. Ltd.

NEW ZEALAND
SMC Pneumatics (N.Z.) Ltd.

SMC offers the same quality and engineering expertise in many other pneumatic components

Valves

Directional Control Valves
Manual Valves
Mufflers
Exhaust Cleaners
Quick Exhaust Valves

Valves

Proportional Valves
Mechanical Valves
Miniature Valves
Fluid Valves

Cylinders/Actuators

Compact Cylinders
Miniature Cylinders
Rodless Cylinders
Rotary Actuators
Pneumatic Grippers

Vacuum

Vacuum Ejectors
Vacuum Accessories

Instrumentation

Pneumatic Positioners
Pneumatic Transducers

Air Preparation Equipment

Filters-Regulators-Lubricators
Coalescing Filters
Micro Mist Separators

Fittings

Air Fittings

SMC Corporation of America

3011 N. Franklin Rd Indianapolis, IN 46226
Tel: (317) 899-4440 • FAX: (317) 899-3102
<http://www.smcusa.com>

SMC Pneumatics (Canada) Ltd.

6768 Financial Drive, Mississauga, Ontario L5N 7J6
Tel: (905) 812-0400 • FAX: (905) 812-8686
<http://www.smcpcanamics.ca>

All reasonable efforts to ensure the accuracy of the information detailed in this catalog were made at the time of publishing. However, SMC can in no way warrant the information herein contained as specifications are subject to change without notice