

Simple Joint/ø32 to ø100

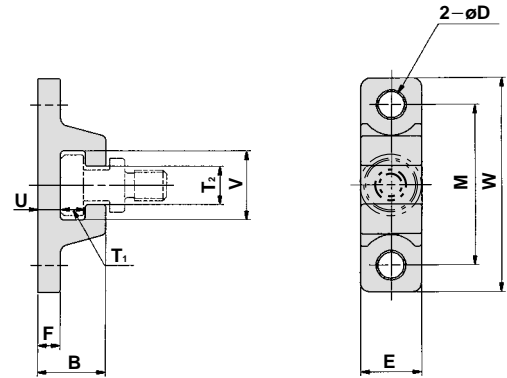

A type mounting bracket



Material: Chrome molybdenum steel (nickel plated)
mm

Joint and mounting bracket (A type, B type) part no.

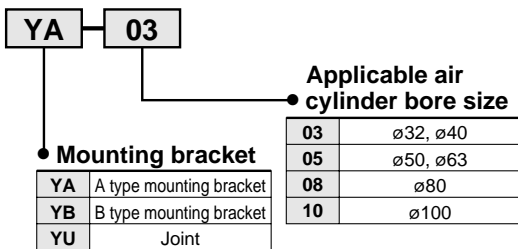

| Part no. | Bore size (mm) | B | D | E | F | M | T ₁ | T ₂ |
|----------|----------------|----|-----|----|----|----|----------------|----------------|
| YA-03 | 32, 40 | 18 | 6.8 | 16 | 6 | 42 | 6.5 | 10 |
| YA-05 | 50, 63 | 20 | 9 | 20 | 8 | 50 | 6.5 | 12 |
| YA-08 | 80 | 26 | 11 | 25 | 10 | 62 | 8.5 | 16 |
| YA-10 | 100 | 31 | 14 | 30 | 12 | 76 | 10.5 | 18 |

| Part no. | Bore size (mm) | U | V | W | Weight (g) |
|----------|----------------|----|----|-----|------------|
| YA-03 | 32, 40 | 6 | 18 | 56 | 55 |
| YA-05 | 50, 63 | 8 | 22 | 67 | 100 |
| YA-08 | 80 | 10 | 28 | 83 | 195 |
| YA-10 | 100 | 12 | 36 | 100 | 340 |

Allowable eccentricity

| Bore size | 32 | 40 | 50 | 63 | 80 | 100 |
|------------------------|-----|----|----|------|----|-----|
| Eccentricity tolerance | ±1 | | | ±1.5 | | ±2 |
| Backlash | 0.5 | | | | | |

<Ordering method>

- Joints are not included with A type and B type mounting brackets. Order them separately.

(Example)

Bore size ø40 Part number

- A type mounting bracket YA-03

- Joint YU-03

Joint part no.

| Bore size (mm) | Joint | Applicable mounting bracket | | Weight (g) |
|----------------|-------|-----------------------------|-------------------------|------------|
| | | A type mounting bracket | B type mounting bracket | |
| 32, 40 | YU-03 | YA-03 | YB-03 | 25 |
| 50, 63 | YU-05 | YA-05 | YB-05 | 40 |
| 80 | YU-08 | YA-08 | YB-08 | 90 |
| 100 | YU-10 | YA-10 | YB-10 | 160 |

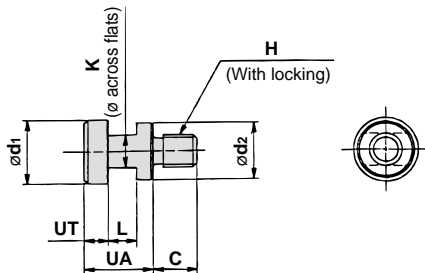

Material: Chrome molybdenum steel (nickel plated)

| Part no. | Applicable bore size (mm) | UA | C | d ₁ | d ₂ | H | K | L | UT | Weight (g) |
|----------|---------------------------|----|----|----------------|----------------|-----------|----|----|----|------------|
| YU-03 | 32, 40 | 17 | 11 | 15.8 | 14 | M8 x 1.25 | 8 | 7 | 6 | 25 |
| YU-05 | 50, 63 | 17 | 13 | 19.8 | 18 | M10 x 1.5 | 10 | 7 | 6 | 40 |
| YU-08 | 80 | 22 | 20 | 24.8 | 23 | M16 x 2 | 13 | 9 | 8 | 90 |
| YU-10 | 100 | 26 | 26 | 29.8 | 28 | M20 x 2.5 | 14 | 11 | 10 | 160 |

B type mounting bracket

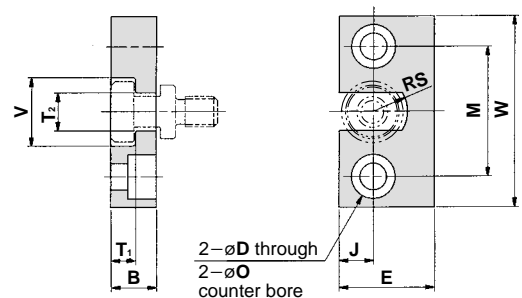

Material: Carbon steel (nickel plated)
mm

| Part no. | Bore size (mm) | B | D | E | J | M | O |
|----------|----------------|----|----|----|----|----|----------------|
| YB-03 | 32, 40 | 12 | 7 | 25 | 9 | 34 | 11.5 depth 7.5 |
| YB-05 | 50, 63 | 12 | 9 | 32 | 11 | 42 | 14.5 depth 8.5 |
| YB-08 | 80 | 16 | 11 | 38 | 13 | 52 | 18 depth 12 |
| YB-10 | 100 | 19 | 14 | 50 | 17 | 62 | 21 depth 14 |

| Part no. | Bore size (mm) | T ₁ | T ₂ | V | W | RS | Weight (g) |
|----------|----------------|----------------|----------------|----|----|----|------------|
| YB-03 | 32, 40 | 6.5 | 10 | 18 | 50 | 9 | 80 |
| YB-05 | 50, 63 | 6.5 | 12 | 22 | 60 | 11 | 120 |
| YB-08 | 80 | 8.5 | 16 | 28 | 75 | 14 | 230 |
| YB-10 | 100 | 10.5 | 18 | 36 | 90 | 18 | 455 |