

3 Position Cylinder

Provides intermediate stop mechanism



Series RZQ
 ø32, ø40, ø50, ø63

- 2-stage stroke enabled with a small increase in length

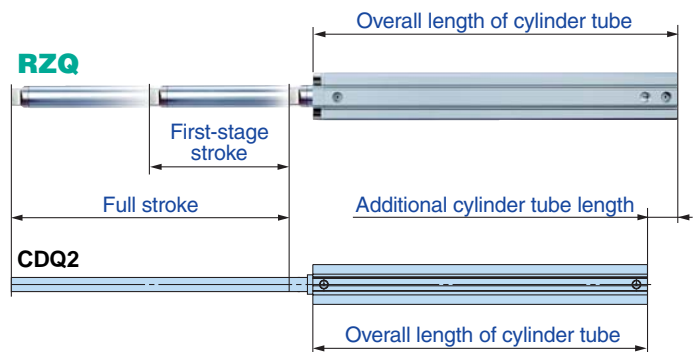

Comparison of cylinder tube overall length (mm)

Full stroke = 300 mm (150 + 150 = 300 mm in case of CG1BN)

Bore Size (mm)	RZQA□-300-150	CDQ2A□-300D	RZQ-CDQ2 Additional cylinder tube length	CG1BN□-150+150-XC11 Dual stroke cylinder
32	382.5	345.5	37	591
40	392	355	37	606
50	396.5	355.5	41	631
63	402	357.5	44.5	631

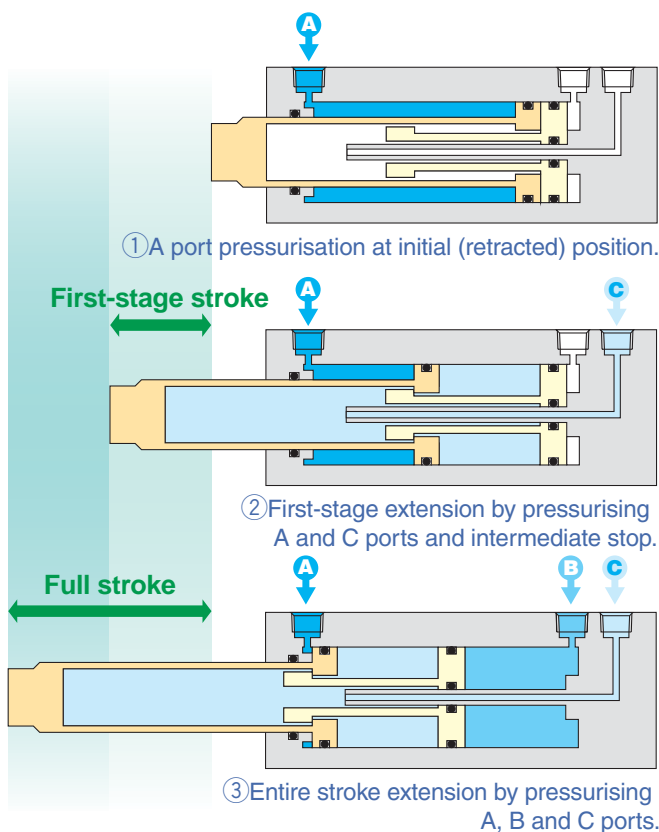

- ◆ **First-stage stroke can be specified without changing the overall length.**
- ◆ **0.02 or less repeatability in intermediate stop positioning**
 High accuracy is achieved by an intermediate stop method of pressing metallic components against each other
- ◆ **Stroke can be freely specified.**
 Full strokes / Standard: Available in 5 mm increments
 Optional: Available in 1 mm increments
 First-stage Stroke / Available in 1 mm increments
- ◆ **Large bore tube rod to withstand lateral load**
 Use of a tube rod with a large bore which is 70% of the piston diameter
- ◆ **Wide variations in mounting**
 Direct mounting: Mounting taps of the same dimensions as those of Series CQ2.
 Through holes are also available for full strokes of 75 mm or less.
 Static mounting: Foot type, Front flange type
 Rotation bracket: Double clevis

3 Position Cylinder

Series RZQ

ø32, ø40, ø50, ø63

How to Order

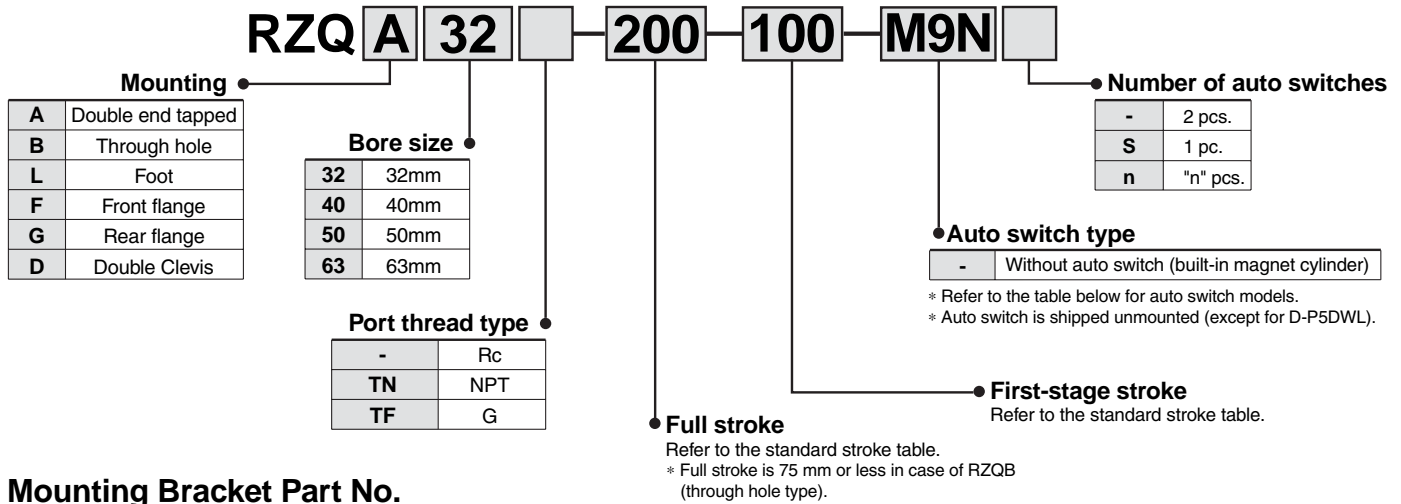

Mounting Bracket Part No.

Bore size (mm)	Foot ^{Note 1)}	Flange	Double Levis ^{Note 2)}
32	RZQ-L032	RZQ-F032	RZQ-D032
40	RZQ-L040	RZQ-F040	RZQ-D040
50	RZQ-L050	RZQ-F050	RZQ-D050
63	RZQ-L063	RZQ-F063	RZQ-D063

Note 1) When ordering foot brackets, order two pieces per cylinder.

Note 2) The following parts are included with each mounting bracket.

Foot, Flange/Body mounting bolts

Double Levis/Clevis pins, C-type snap ring for axis, Body mounting bolts

Applicable Auto Switches/Refer to Pneumatics catalogue for detailed auto switch specifications.

Type	Special function	Electrical entry	Indicator light	Wiring (output)	Load voltage		Rail mounting		Direct mounting		Lead wire length* (m)				Pre-wired connector	Applicable load			
					DC	AC	Perpendicular	In-line	Perpendicular	In-line	0.5 (Nil)	3 (L)	5 (Z)	None (N)		IC circuit	Relay, PLC		
Reed switch	—	Grommet	Yes	3-wire (NPN)	—	5V	—	—	A76H	A96V	A96	●	●	—	—	—	IC circuit	—	
				2-wire	—	—	200V	A72	A72H	—	—	●	●	—	—	—	—	—	—
					12V	100V	A73	A73H	—	—	●	●	●	●	—	—	—	—	—
		Connector	Yes	24V	5V, 12V	100V or less	A80	A80H	A90V	A90	●	●	—	—	—	—	—	IC circuit	Relay, PLC
					12V	—	A73C	—	—	—	●	●	●	●	—	—	—	—	
				5V, 12V	24V or less	A80C	—	—	—	●	●	●	●	—	—	—	—	IC circuit	
Diagnostic indication (2-colour indicator)	Grommet	Yes	—	—	A79W	—	—	—	●	●	—	—	—	—	—	—			
Solid state switch	—	Grommet	Yes	3-wire (NPN)	24V	5V, 12V	—	F7NV	F79	M9NV	M9N	●	●	○	—	○	IC circuit	Relay, PLC	
				3-wire (PNP)				F7PV	F7P	M9PV	M9P	●	●	○	—	○	—		—
		Connector		2-wire	12V	F7BV	J79	M9BV	M9B	●	●	○	—	○	—	—	—		
				3-wire (NPN)	5V, 12V	F7NVV	F79W	M9NVV	M9NW	●	●	○	—	○	—	○	IC circuit		
		3-wire (PNP)		—		F7PW	M9PWW	M9PW	●	●	○	—	○	—	—	—			
		Grommet		2-wire	12V	F7BWW	J79W	M9BWW	M9BW	●	●	○	—	○	—	—	—		
				Water resistant (2-colour indicator)	—	F7BA	—	M9BA	—	●	●	○	—	○	—	—	—		
		Grommet		Yes	2-wire	12V	F7BAV	—	—	—	—	●	●	○	—	—	—		—
							With diagnostic output (2-colour display)	—	F79F	—	—	—	●	●	○	—	○		IC circuit
		Magnetic field resistant (2-colour display)		—	—	—	—	—	—	—	—	●	●	—	—	○	—		—

* Lead wire length symbols: 0.5m Nil (Example) A73C
3m L A73CL
5m Z A73CZ
None N A73CN

* Auto switches marked with a "○" symbol are produced upon receipt of order.

• D-P5DWL is available in sizes ø40 to ø63.

• In addition to the models in the above table, there are some other auto switches that are applicable. For more information, refer to page 13.

• Refer to Best Pneumatics catalogue for solid state switch with pre-wired connector.

Specifications



Bore size (mm)	32	40	50	63
Action	Double acting single rod			
Fluid	Air			
Proof pressure	1.5MPa			
Maximum operating pressure	1.0MPa			
Minimum operating pressure	0.1MPa			
Ambient and fluid temperature	-10 to 60C (with no freezing)			
Lubrication	Non-lube			
Operating piston speed	50 to 300mm/s			
Stroke length tolerance	+1.5 0			
Cushion	Rubber bumper at the end of full stroke ^{Note)}			
Thread tolerance	JIS class 2			
Port size (Rc,NPT,G)	1/8		1/4	

Note) No rubber bumper at the end of the first-stage stroke (at intermediate stop)

Standard Strokes

Full stroke ^{Note 1)}	25, 50, 75, 100, 125, 150, 175, 200, 250, 300
First-stage stroke ^{Note 2)}	5 mm to "Full stroke" -1 mm

Note 1) RZQB (through hole type) is only available for full strokes 25, 50 and 75.
 Note 2) Available in 1 mm increments.
 Note 3) Please pay attention to the minimum stroke when mounting an auto switch. (Refer to page 13)

Manufacture of Intermediate Strokes

Method	Spacers installed in standard stroke body.
Ordering	Refer to standard part number and ordering on page 1.
Description	Strokes are available in 5 mm increments by installing spacers in standard stroke cylinders.
Stroke range	Only available for full strokes of 5 to 295 mm
Example	Part number: RZQA50-135-50 A 15 mm spacer is installed in a standard cylinder RZQA50-150-50. The B dimension is 246.5 mm.

How to order strokes

RZQA32-150-78

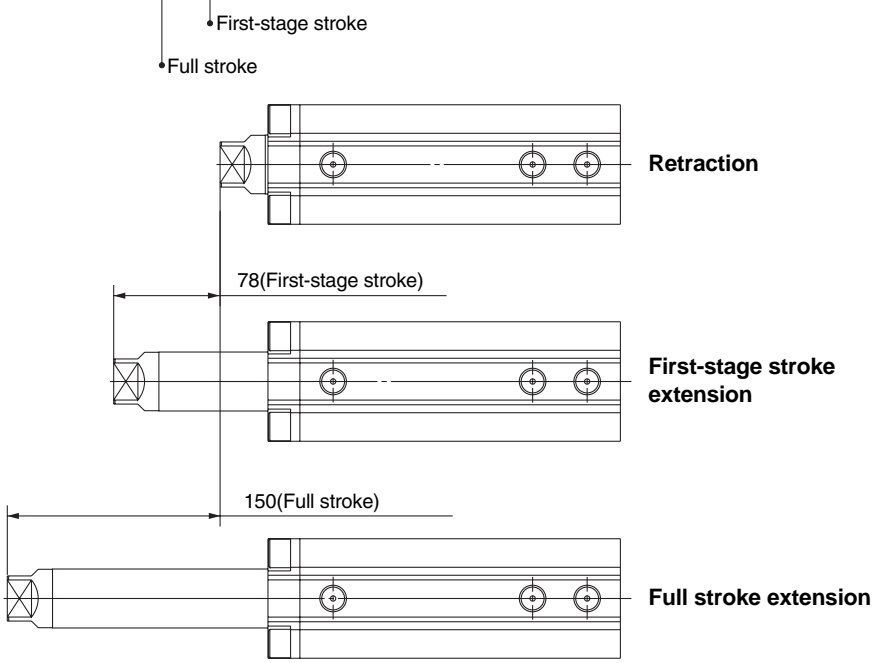

* Consult SMC for intermediate strokes of a full stroke.

Theoretical Output

Theoretical Output **Table 1**

[N]

Bore size (mm)	Piston area [mm ²]				Air pressure [MPa] (with same air pressure applied to each port)											
					First stage (Retraction end ↔ Intermediate stop position)						Second stage (Intermediate stop position ↔ Extension end)					
	Piston A		Piston B		Extension			Retraction			Extension			Retraction		
	Front side ①*	Rear side ②*	Front side ③*	Rear side ④*	0.3	0.5	0.7	0.3	0.5	0.7	0.3	0.5	0.7	0.3	0.5	0.7
32	410	804	792	792	118	197	276	123	205	287	118	197	276	119	199	279
40	641	1257	1244	1244	185	308	431	192	321	449	185	308	431	188	314	440
50	1001	1963	1935	1935	289	481	673	300	501	701	289	481	673	292	487	681
63	1527	3117	3067	3067	477	795	1113	458	764	1069	477	795	1113	443	739	1034

Theoretical Output

Action	First stage (Retraction end ↔ Intermediate stop position)				Second stage (Intermediate stop position ↔ Extension end)				
	Extension		Retraction		Extension		Retraction		
Pressure port	A	C	A	A	A	B	C	A	C
Air pressure [MPa]	P _A	P _C	P _A	P _A	P _A	P _B *	P _C *	P _A	P _C
Formula for theoretical output F[N]	F = -① x P _A + ② x P _C		F = ① x P _A		F = -① x P _A + ④ x P _B + (② - ③) x P _C			F = ① x P _A + (③ - ②) x P _C	

* ①, ② and ③ are piston areas. (Refer to [Table 1](#).)

* Assume P_B ≤ P_C.

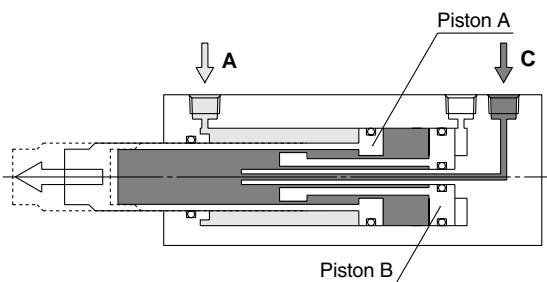

First-stage extension

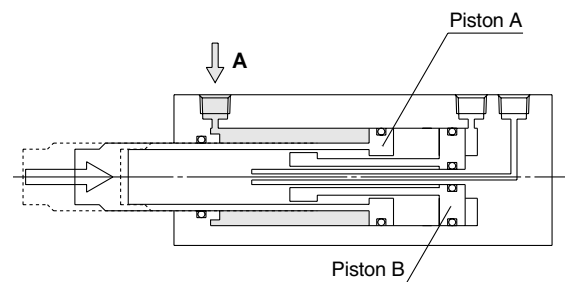

First-stage retraction

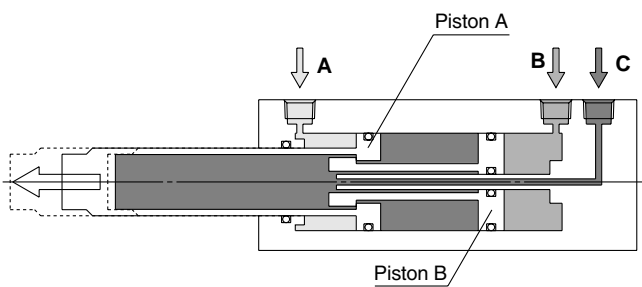

Second-stage extension

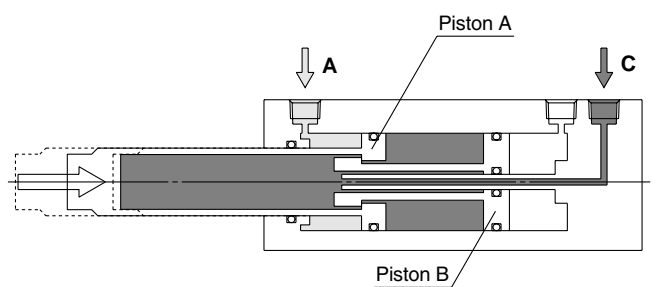

Second-stage retraction

Weight

Weight Table

Unit: kg

Bore size (mm)	Cylinder stroke									
	25-5	50-5	75-5	100-5	125-5	150-5	175-5	200-5	250-5	300-5
32	0.81	0.88	0.94	1.01	1.07	1.13	1.20	1.26	1.39	1.52
40	1.19	1.27	1.35	1.43	1.50	1.58	1.66	1.73	1.89	2.04
50	1.80	1.92	2.04	2.16	2.28	2.40	2.52	2.64	2.89	3.13
63	2.53	2.71	2.87	3.04	3.20	3.36	3.53	3.69	4.02	4.35

Note) Calculate the first-stage stroke referring to the values for "10 mm increase" in the Additional Weight [Table 2](#) below.

Additional Weight [Table 2](#)

Unit: g

Item	Model	Bore size (mm)			
		32	40	50	63
10 mm increase of first-stage stroke	RZQ□	3	3	6	15
Foot type (including bolts)	RZQL	143	155	243	324
Flange type (including bolts)	RZQG,RZQF	165	198	348	534
Double clevis type (including bolts, pins and snap ring)	RZQD	151	196	393	554

Note) Add the weight in [Table 2](#) to those in Weight Table.

RZQB Mounting Bolt

Mounting / Mounting bolts for the through hole type RZQB are available.

How to order: Add "Bolt" in front of the bolts to be used.

(Example) Bolt M5 x 110ℓ

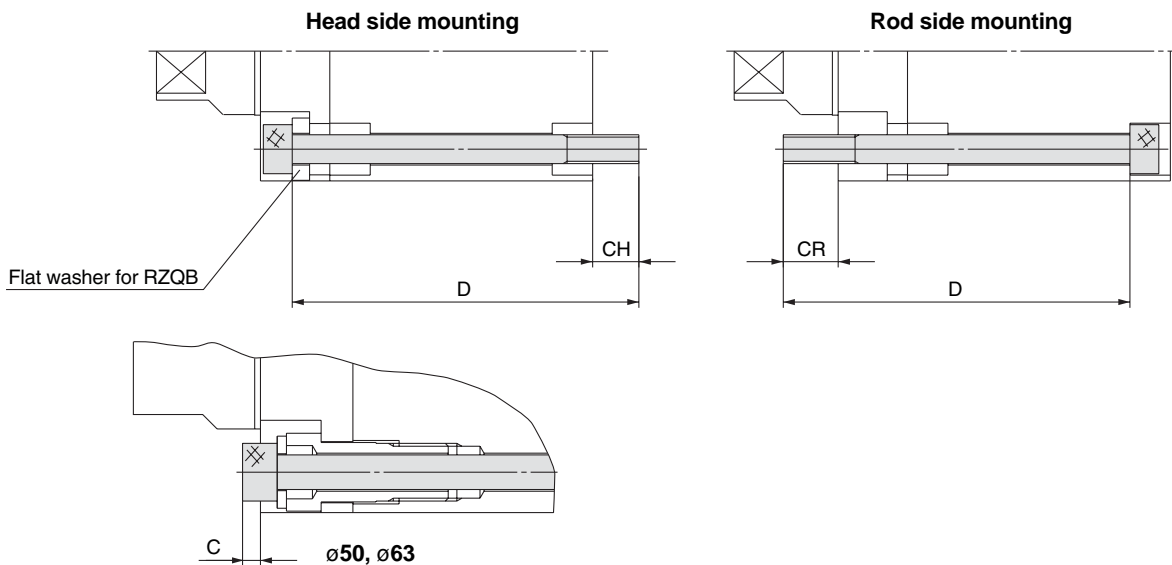

Note) Use the attached washer when inserting the bolt from the rod side.

RZQB Mounting Bolt

Model	CH	CR	C	D	Mounting bolt	No. of bolts	Attached flat washer part no.		
RZQB32-25-□	8	9.5	-	110	M5 x 110ℓ	2 pcs.	RZQ32-12-S7515		
RZQB32-50-□				135	M5 x 135ℓ				
RZQB32-75-□				160	M5 x 160ℓ				
RZQB40-25-□	8.5	10	-	120	M5 x 120ℓ				
RZQB40-50-□				145	M5 x 145ℓ				
RZQB40-75-□				170	M5 x 170ℓ				
RZQB50-25-□	11.5	16.5	3	130	M6 x 130ℓ	4 pcs.	JIS flat washer Nominal diameter 6		
RZQB50-50-□				155	M6 x 155ℓ				
RZQB50-75-□				180	M6 x 180ℓ				
RZQB63-25-□	12.5	17.5	3.5	135	M8 x 135ℓ			4 pcs.	JIS flat washer Nominal diameter 8
RZQB63-50-□				160	M8 x 160ℓ				
RZQB63-75-□				185	M8 x 185ℓ				

Model Selection

Selection chart for pneumatic circuit and selection graph

Select the pneumatic circuit and selection graph according to the following chart.

1) Transfer direction of load

Vertical movement → Circuit **A**, Graph **1**
 Horizontal movement → Circuit **A**, Graph **1**
 (* Load is received by guide.)

2) Cylinder orientation

Up → Circuit **A**, Graph **2**
 Down → Circuit **A**, Graph **2**

3) Cylinder load ratio

0.25 to 0.5 → Circuit **B**, Graph **2**
 Less than 0.25 → Circuit **B**, Graph **2**

Circuit **C**, Graph **1**, Minimum load weight = Graph **2**

$$\text{Load factor} = \frac{W}{\frac{D^2}{4} \cdot \pi \times P_1}$$

W : Load weight [N]
 D : Cylinder bore size [mm]
 P₁ : Air pressure (Original pressure) [MPa]

Selection graph

The optimum size is determined from the intersection of the operating pressure and load weight.

Graph **1**

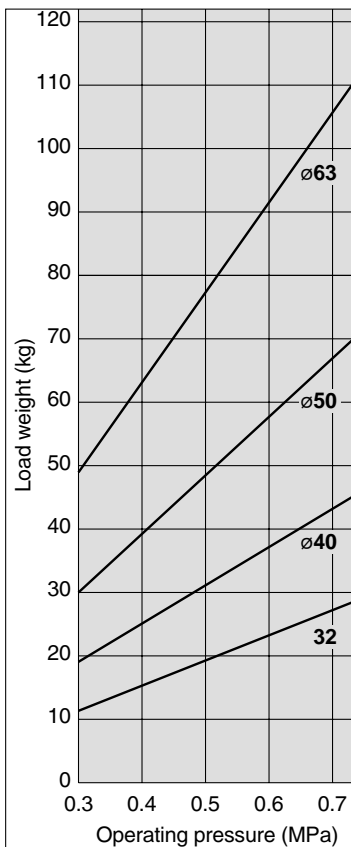

Graph **2**

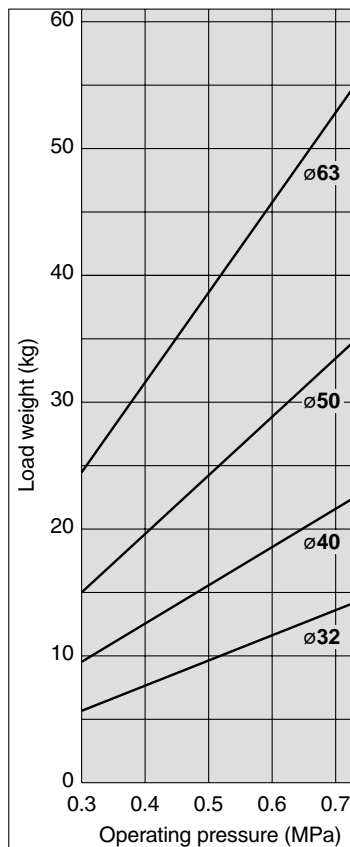

Selection example

Selection conditions: Transfer direction: Vertical movement
 Cylinder orientation: Down
 Load weight: 15 kg
 Operating pressure: 0.4 MPa

→ Circuit **A** and Graph **2** are selected according to the chart.

Find the intersection of an operation pressure of 0.4 MPa and load weight of 15 kg in Graph **2**.

→ ø50 is selected.

Pneumatic circuit

Circuit **A**

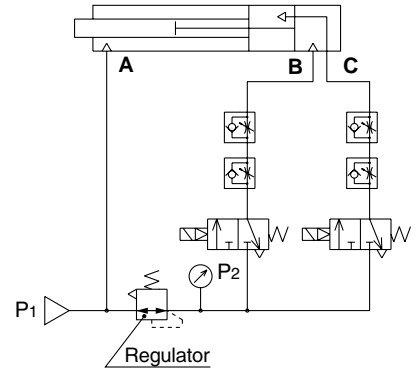

Circuit **B**

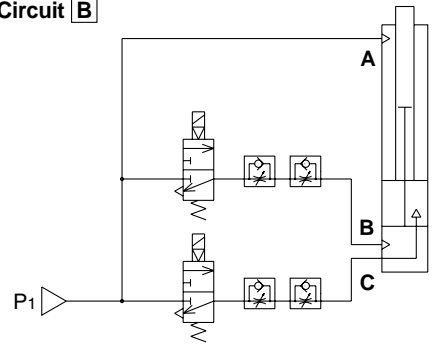

Circuit **C**

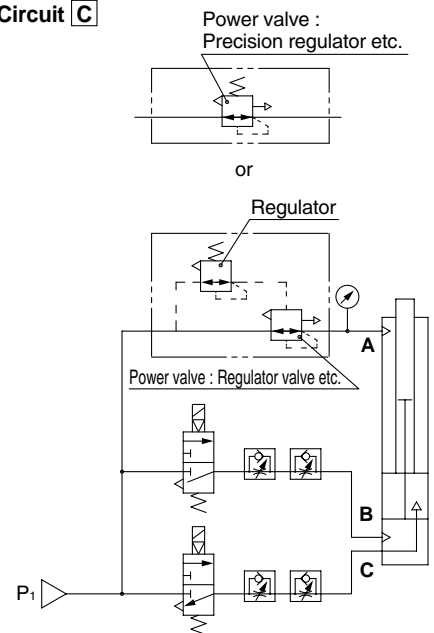

* Use a regulator with a large volume of exhaust flow such as a Power Valve (Regulator valve or Precision regulator), etc. to adjust the air pressure on the A port. If the exhaust flow volume is low, the speed of the cylinder becomes slow.

Confirmation of allowable kinetic energy

Confirm the internal stopper strength at extension and retraction ends in the graph on page 7.

Pneumatic Circuit Adjustment

Regulator set pressure

Set the pressures of circuit **A** and circuit **C** regulators at values found by the formula in the following table.

Circuit	Orientation	Bore size (mm)	P ₂ [MPa]
A	Horizontal	—	0.75P ₁
A	Down	32	0.75P ₁ -0.012m
		40	0.75P ₁ -0.0078m
		50	0.75P ₁ -0.0050m
C	Up	32	1.5P ₁ -0.024m
		40	1.5P ₁ -0.016m
		50	1.5P ₁ -0.010m
		63	1.5P ₁ -0.0063m

P₁: Operating pressure [MPa], m: Load weight [kg]

* In cases with load fluctuations, substitute the median value of the weight.

Example) Assume circuit **C** with an operating pressure of 0.5 MPa, load weight of 10 kg, fluctuation to 20 kg and a cylinder bore of 32 mm.

$$\rightarrow P_2 = 1.5 \times 0.5 - 0.024 \times 15 = 0.39 \text{ MPa}$$

Speed adjustment

The data below illustrates the strokes controlled by the respective speed controllers. Gradually increase from a low speed to the desired speed setting.

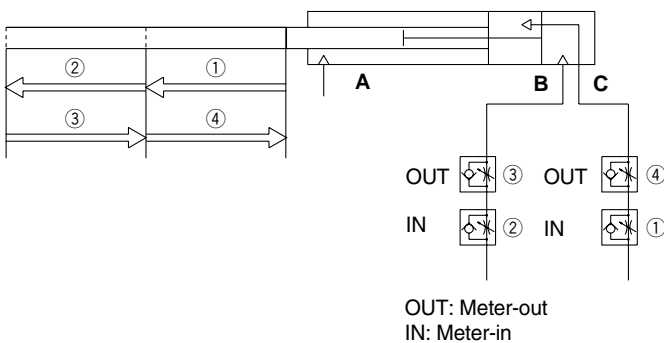

Overrun at intermediate stop

When stopping at an intermediate point, the cylinder first moves the piston past the intermediate point and then returns it. To confirm this distance of an extra travel (overrun) in Graph **3**, Lines ① to ④ can be selected from the following table.

Circuit	Orientation	Movement	Line
A	Horizontal	Extension	③
		Retraction	④
A	Down	Extension	③
		Retraction	③
B	Up	Extension	①
		Retraction	③
C	Up	Extension	②
		Retraction	④

The above values are for cases where the maximum payload found by the selection method is loaded.

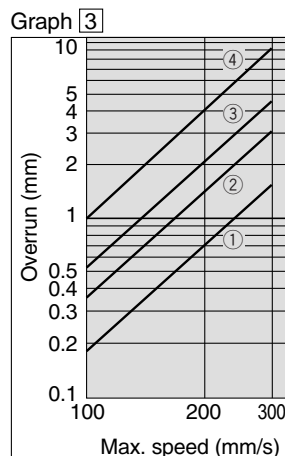

Change of the return point at the time of power failure

At the time of power failure, circuits **A**, **B** and **C** return the piston to the retraction end.

To return the piston to the intermediate point at the time of power failure, add changes to the 3 port valve (valve 2) on the cylinder rear side so that it will be normally open.

To return the piston to the extension end at the time of power failure, add changes to both 3 port valves so that they will be normally open.

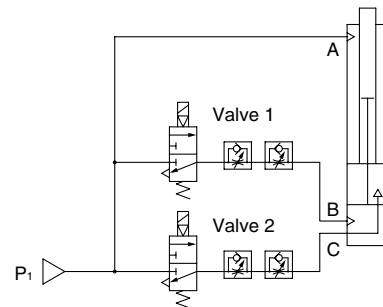

Returns to the retracted end at the time of a power failure

Valve 1 : Normally close, Valve 2 : Normally close

Returns to the intermediate position at the time of a power failure

Valve 1 : Normally close, Valve 2 : Normally open

Returns to the extended end at the time of a power failure

Valve 1 : Normally open, Valve 2 : Normally open

Change to motion holding circuit

To hold the present motion at the time of power failure instead of performing a return to the specified stop point, change both 3 port valves to 5 port double valves and plug A or B port, whichever is open.

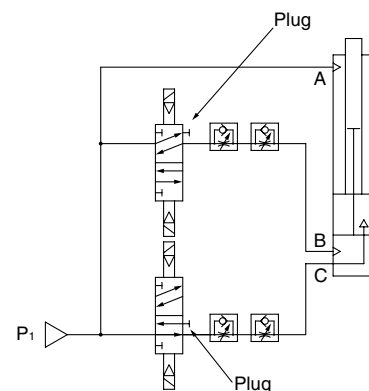



Series RZQ Specific Product Precautions

Be sure to read before handling.

Selection

Caution

1. Keep the relationship between the load weight and the maximum speed below the limit lines in Graph 1. If it exceeds the limit line, receive the load with an external stopper.

Operation beyond the limiting lines will cause damage to machinery.

Graph 1

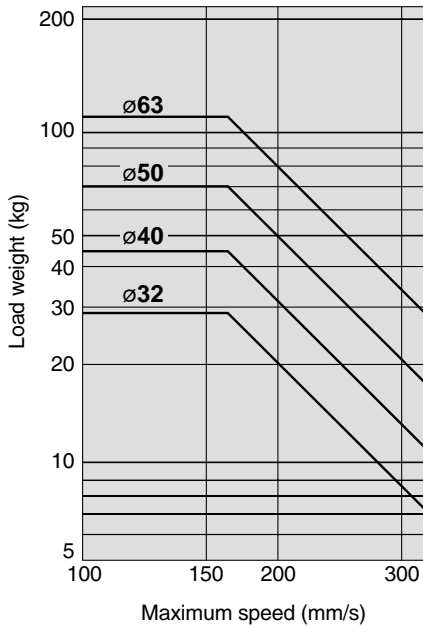

2. Use the cylinder in applications in which the overrun will not cause any problem.

When stopping at an intermediate point, this cylinder first moves the piston past the intermediate point and then returns it. Confirm this distance of an extra travel (overrun) in Graph 3 on page 6 and use the cylinder in applications in which the overrun will not cause any problem.

3. In cases where a positioning repeatability of 0.1 mm or less is required at the retraction and extension ends, use an external stopper for stops.

Use of an internal stopper will result in approximately 0.1 mm of displacement due to changes in the operating pressure and external forces.

4. Use an external guide to receive a moment or torque which can generate a load.

If a moment or torque directly acts on the cylinder, it will lead to reduced service life or damage to machinery.

5. To connect a direct acting guide, use floating joints in the following table.

If the direct acting guide is directly connected in operation, it may lead to malfunction or reduced service life.

Model	Applicable floating joint
RZQ□32	JB40-8-125
RZQ□40,50	JB63-10-150
RZQ□63	JB80-16-200

Selection

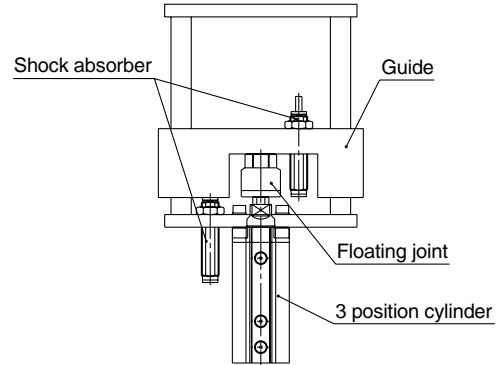

6. When the kinetic energy of a load (driven object and moving parts) exceeds the allowable kinetic energy in Table 3, add an absorption mechanism, such as a shock absorber as illustrated above.

Table 3

Bore size (mm)	Allowable kinetic energy (J)
32	0.29
40	0.52
50	0.91
63	1.54

The kinetic energy of a load can be expressed by the formula given below.

$$E = \frac{M+m}{2} V^2$$

E=Kinetic energy (J)

M=Weight of driven object (kg)

m=Weight of moving parts (kg)

V=Piston speed (m/s)

Selection data

RZQ moving parts weight table

Unit : kg

Bore size (mm)	Cylinder stroke									
	25-5	50-5	75-5	100-5	125-5	150-5	175-5	200-5	250-5	300-5
32	0.18	0.21	0.23	0.26	0.29	0.32	0.34	0.37	0.43	0.48
40	0.31	0.35	0.39	0.43	0.46	0.50	0.54	0.58	0.66	0.74
50	0.58	0.63	0.68	0.73	0.78	0.83	0.88	0.93	1.03	1.13
63	0.73	0.80	0.86	0.93	0.99	1.06	1.12	1.19	1.33	1.45

* Calculate the first-stage stroke referring to the values for "10 mm increase" in the Additional weight below.

Additional weight table

Unit : g

Cylinder bore size (mm)	$\phi 32$	$\phi 40$	$\phi 50$	$\phi 63$
10 mm increase of first-stage stroke	3	3	6	15

Maintenance

Caution

1. If reapplication of grease is needed, apply grease specifically provided for this purpose:

Grease: Product name: Grease pack

Part No.: 10 g GR-L-010

150 g GR-L-150

2. When dynamic seals are replaced, use a seal kit provided for each bore size.

Dedicated seal kit: Refer to Construction on page 8.

Construction

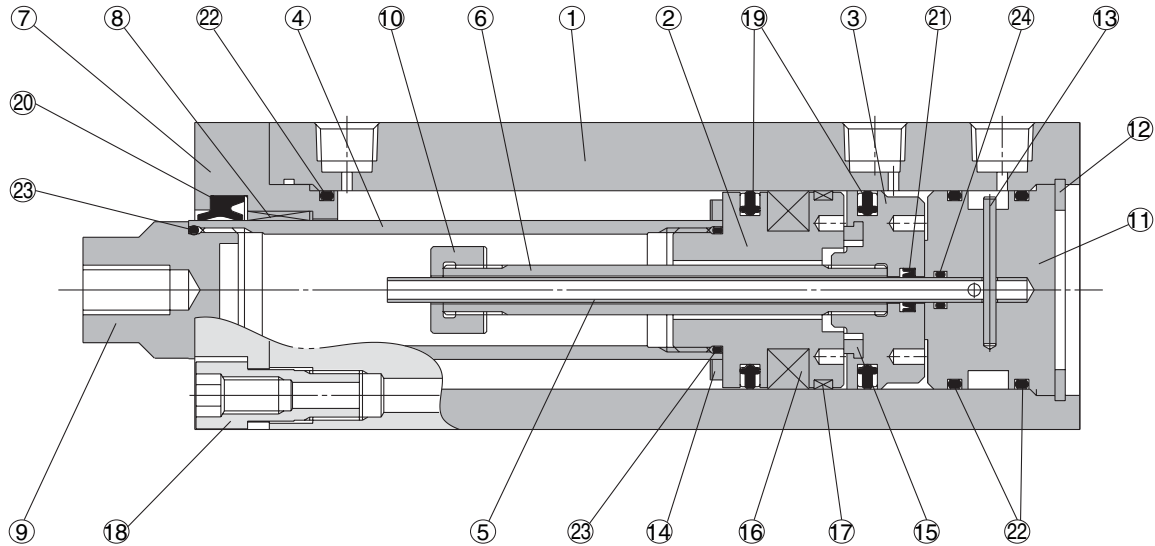

Parts List

No.	Description	Material	Note
1	Cylinder tube	Aluminum alloy	Hard anodized
2	Piston A	Aluminum alloy	Chromated
3	Piston B	Aluminum alloy	Chromated
4	Tube rod	Carbon steel	Hard chrome plated
5	Inner pipe	Stainless steel	
6	Outer pipe	Carbon steel	Zinc chromated
7	Rod cover	Aluminum alloy	White hard anodized
8	Bushing	Special friction lining	
9	Tube rod cover	Carbon steel	Electroless nickel plated
10	Nut	Carbon steel	Zinc chromated
11	Head cover	Aluminum alloy	Colour less chromated
12	Snap ring	Carbon tool steel	Phosphate coated

No.	Description	Material	Note
13	Parallel pin	Carbon steel	
14	Bumper A	Polyurethane	
15	Bumper B	Polyurethane	
16	Magnet	Synthetic rubber	
17	Wear ring	Resin	
18	Fitting bolt	Carbon steel	Nickel plated
19	Piston seal	NBR	
20	Rod seal A	NBR	
21	Rod seal B	NBR	
22	Gasket A	NBR	
23	Gasket B	NBR	
24	Gasket C	NBR	

Replacement Parts/Seal Kits

Bore size (mm)	Seal kit No.	Contents
32	RZQ32-PS	A set of Nos. 19, 20, 21, 22 and 24 from the table above
40	RZQ40-PS	
50	RZQ50-PS	
63	RZQ63-PS	

* Seal kits are sets consisting of items 19, 20, 21, 22 and 24 and can be ordered using the seal kit number for each cylinder bore size.

Series RZQ

Dimensions

Standard type (Double end tapped type)/RZQA

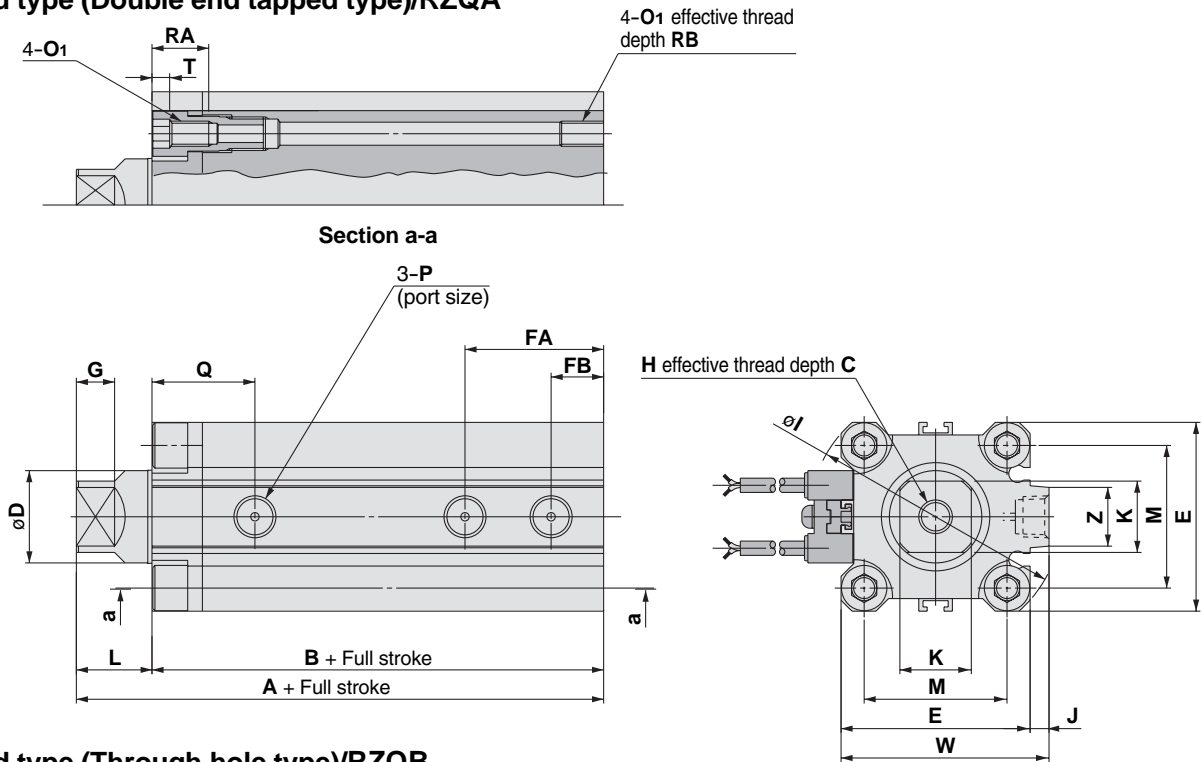

Standard type (Through hole type)/RZQB

ø32, ø40

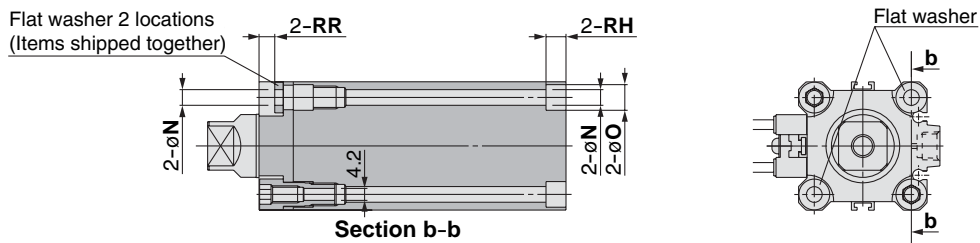

Use the through-hole on 2 locations for mounting.

ø50, ø63

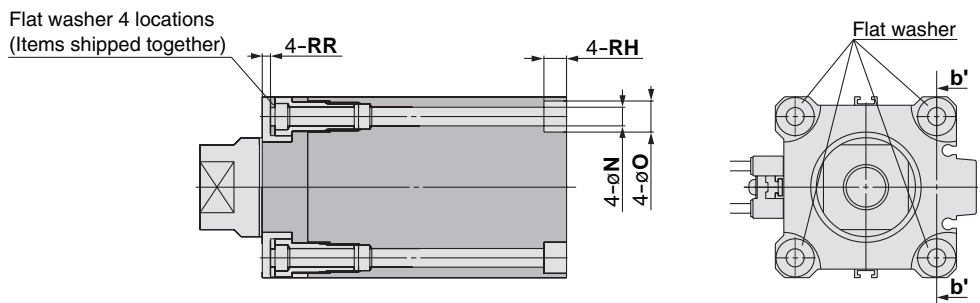

Use the through-hole on 4 locations for mounting.

Bore size (mm)	A	B	C	D	E	FA	FB	G	H	I	J	K	L	M	N	O ₁	O	P	Q	RA	RB	RR	RH	T	W	Z
32	100.5	82.5	14	22.4	45	33	12.5	9	M8	60	4.5	17	18	34	5.5	M6	9	1/8	24.5	14	10	5.5	7	4.5	49.5	14
40	110	92	16	28	52	35	14	9	M10	69	5	24	18	40	5.5	M6	9	1/8	26	14	10	5.5	7	4.5	57	14
50	118.5	96.5	16	35	64	37	14	12	M10	86	7	30	22	50	6.6	M8	11	1/4	30	17	14	3	8	5.5	71	19
63	130	102	21	45	77	39.5	16.5	15	M16	103	7	36	28	60	9	M10	14	1/4	36.5	21.5	18	4.5	10.5	6.5	84	19

(mm)

Foot type/RZQL

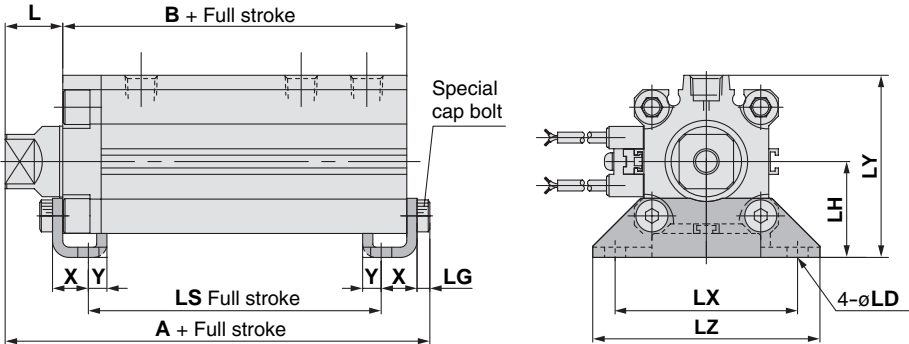

Foot (mm)

Bore size (mm)	A	B	L	LD	LG	LH	LS
32	107.7	82.5	18	6.6	4	30	66.5
40	117.2	92	18	6.6	4	33	76
50	126.7	96.5	22	9	5	39	73.5
63	138.2	102	28	11	5	46	76

Bore size (mm)	LX	LY	LZ	X	Y
32	57	57	71	11.2	5.8
40	64	64	78	11.2	7
50	79	78	95	14.7	8
63	95	91.5	113	16.2	9

Front flange type/RZQF

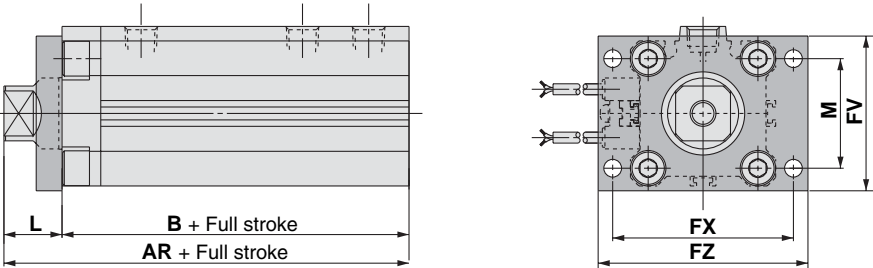

Flange (mm)

Bore size (mm)	AR	AH	B	FD	FT	FV	FX
32	100.5	108.5	82.5	5.5	8	50	56
40	110	118	92	5.5	8	56	62
50	118.5	127.5	96.5	6.6	9	67	76
63	130	139	102	9	9	90	92

Bore size (mm)	FZ	L	M
32	65	18	34
40	72	18	40
50	90	22	50
63	108	28	60

Rear flange type/RZQG

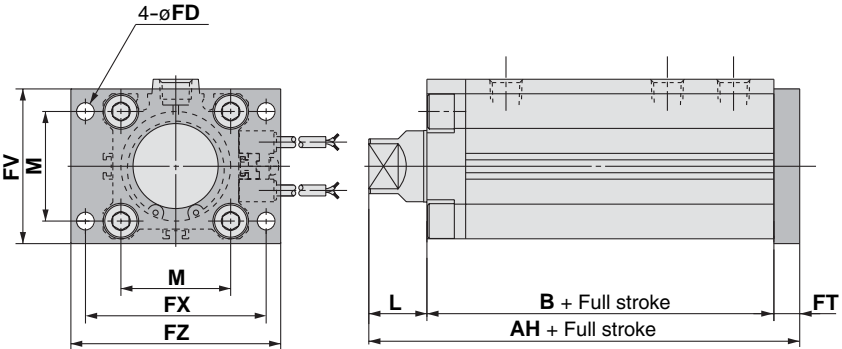

Double clevis type/RZQD

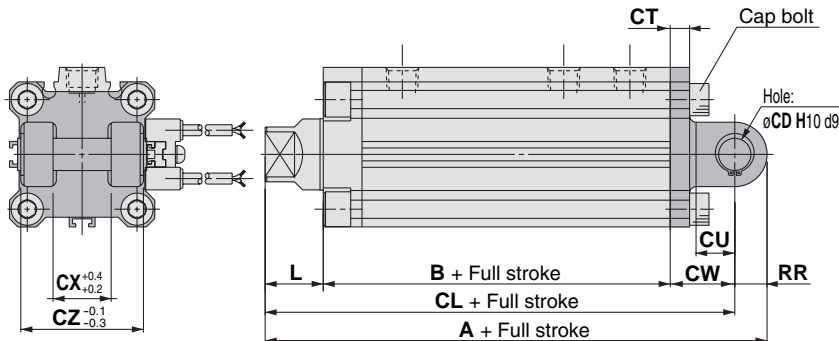

Double clevis (mm)

Bore size (mm)	A	B	CD	CL	CT	CU	CW
32	130.5	82.5	10	120.5	5	14	20
40	142	92	10	132	6	14	22
50	160.5	96.5	14	146.5	7	20	28
63	174	102	14	160	8	20	30

Bore size (mm)	CX	CZ	L	RR
32	18	36	18	10
40	18	36	18	10
50	22	44	22	14
63	22	44	28	14

Series RZQ

Auto Switches Proper Mounting Position (For Detection of Piston A Stop Position) and Mounting Height

D-A7□
D-A80

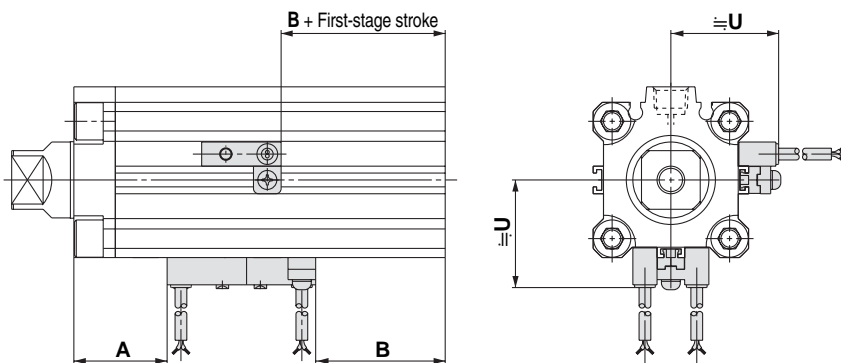

D-A7□H
D-A80H
D-F7□
D-J79
D-F7□W
D-J79W
D-F79F
D-F7NTL
D-F7BAL

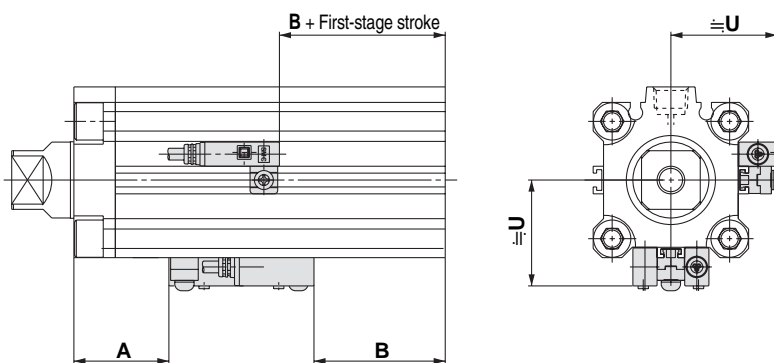

D-A73C
D-A80C
D-J79C

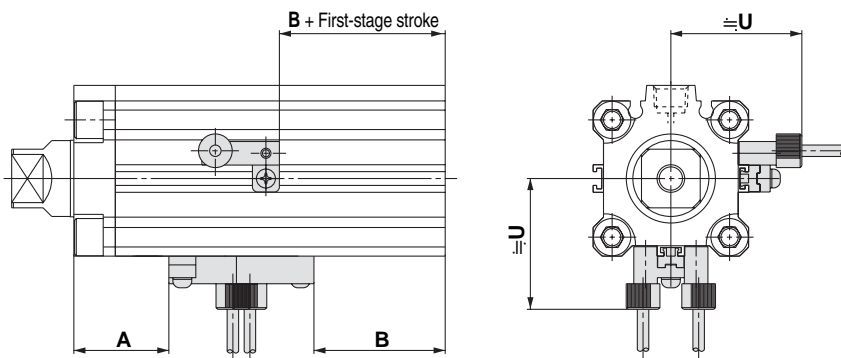

D-A79W
D-F7□WV
D-F7□V
D-F7BAVL

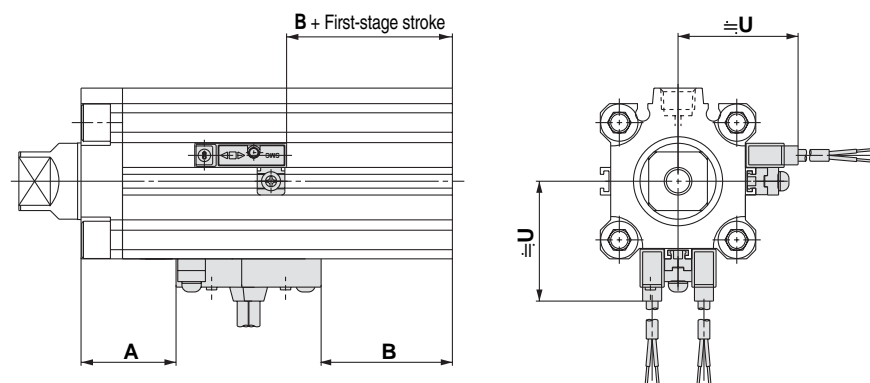

In the case of mounting on the same surface

Cylinder bore size: $\phi 32$ to 63

When the full stroke length is 75 mm or longer.: 3 pcs. are mountable on the same surface.

When the full stroke length is under 75 mm.: 2 pcs. are mountable on the same surface.

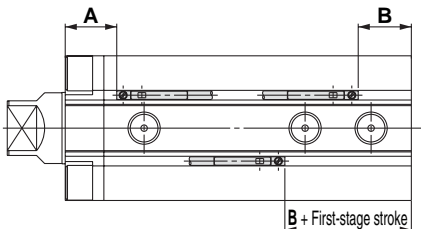

D-A9□
D-M9□
D-M9□W

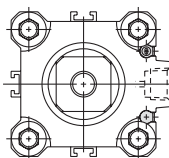

D-A9□V
D-M9□V
D-M9□WV

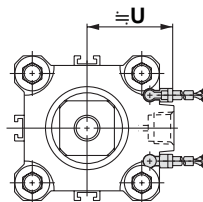

D-M9BAL

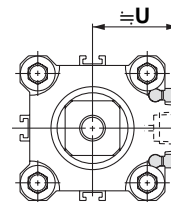

In the case of mounting on another surface

When the cylinder bore size is $\phi 63$, it is mountable on another surface.

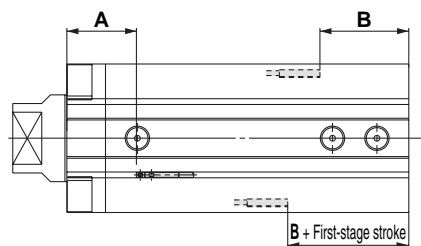

D-A9□
D-M9□
D-M9□W

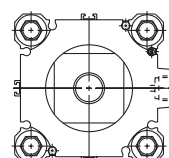

D-A9□V
D-M9□V
D-M9□WV

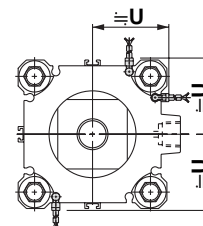

D-M9BAL

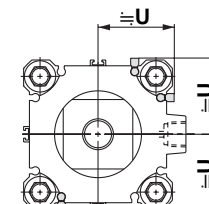

D-P5DW
 $\phi 40, 50, 63$

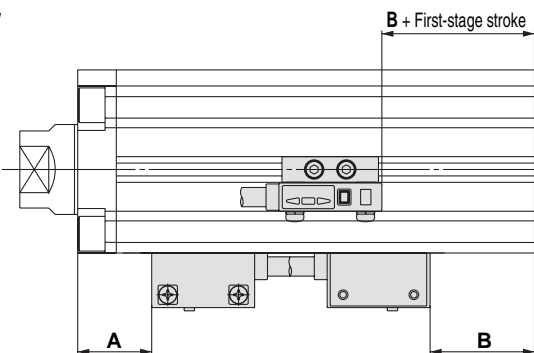

Mounted on different side in case of a full stroke of 25 mm or less

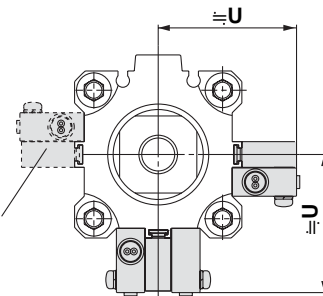

Proper Mounting Position

* Figures in the table below are references for auto switch mounting positions in the stroke end detection. In an actual setting, confirm the auto switch operating conditions, then adjust it.

[mm]

Bore size (mm)	D-A7□,A80		D-A7□H,A80H D-A73C,A80C D-F7□,J79,J79W D-F7□V,J79C D-F7□W,F7□WV D-F7BAL,F7BAVL D-F79F		D-A79W		D-A9□ D-A9□V		D-M9□ D-M9□V D-M9□W D-M9□WV		D-M9BAL		D-P5DWL		D-A7□,A80
	A	B	A	B	A	B	A	B	A	B	A	B	A	B	U
32	27	37.5	27.5	38	24.5	35	26	36.5	30	40.5	29	39.5	—	—	31.5
40	31	43	31.5	43.5	28.5	40.5	30	42	34	46	33	45	27	39	35
50	33.5	44	34	44.5	31	41.5	32.5	43	36.5	47	35.5	46	29.5	40	41
63	37	47	37.5	47.5	34.5	44.5	36	46	40	50	39	49	33	43	47.5

Bore size (mm)	D-A7□H,A80H D-F7□,D-F7□F D-J79,J79W D-F7□W D-F7BAL D-F7NTL	D-A73C D-A80C	D-F7□V D-F7□WV D-F7BAVL	D-J79C	D-A79W	D-A9□V	D-M9□V D-M9□WV	D-M9BAL	D-P5DWL
	U	U	U	U	U	U	U	U	U
32	32.5	38.5	35	38	34	27	29	26.5	—
40	36	42	38.5	41.5	37.5	30.5	32.5	30	44
50	42	48	44.5	47.5	43.5	36.5	38.5	36	50
63	48.5	54.5	51	54	50	40	42	39.5	56.5

Series RZQ

Auto Switch Mounting

Follow the procedures below to mount auto switches.

Direct mounting

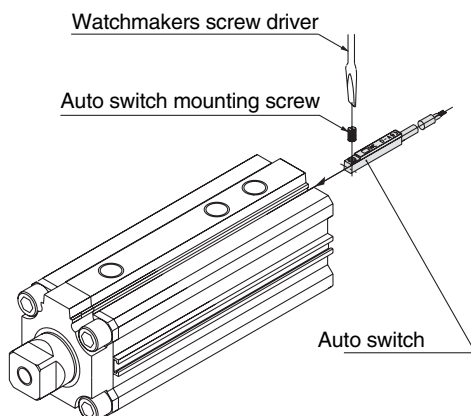

- When tightening the auto switch mounting screw, use a watchmakers screw driver with a handle about 5 to 6mm in diameter. Tighten with a torque of 0.10 to 0.20N·m.

Rail mounting

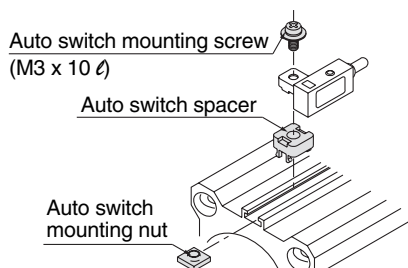

- Apply a tightening torque of 0.5 to 0.7N·m to the auto switch mounting screw.

* Auto switch mounting brackets are included with a cylinder with built-in magnet.

Auto switch mounting bracket/Part No. (Rail mount)

Bore size (mm)	Mounting Bracket Part No.	Note
32, 40 50, 63	BQ-2	<ul style="list-style-type: none"> • Switch mounting screws (M3 x 0.5 x 10ℓ) • Switch spacer • Switch mounting nut

Applicable switch	
Reed switch	Solid state switch
D-A7□, A80	D-F7□, J79
D-A73C, A80C	D-F7□V
D-A7□H, A80H	D-J79C
D-A79W	D-F7□W, J79W
	D-F7□WV
	D-F7BAL
	D-F79F
	D-F7NTL

[Stainless steel mounting screw kit]
Use the following stainless steel mounting screw kit (including nuts) if the operating environment requires. (Auto switch spacer must be ordered separately.)
BBA2: D-A7/A8/F7/J7

The above stainless steel screw kit is used for water resistant auto switch type D-F7BAL when they are shipped mounted on a cylinder.
Also, BBA2 is included when an auto switch alone is shipped.

Minimum Strokes for Auto Switch Mounting

No. of auto switches		D-F7□V D-J79C D-M9□V	D-A80 D-A73C D-A80C D-A9□V	D-F7□WV D-M9□WV D-F7BAVL	D-A7□H D-A80H	D-F7□ D-J79 D-M9□	D-M9□W	D-A79W	D-J79W D-F7BAL D-F79F D-M9BAL	D-A9□	D-P5DWL
1 pc.	Full stroke	5	5	10	15	15	15	15	20	10	15
2 pcs.	Full stroke	5	10	15	15	15	15	20	20	10	15
3 pcs.	First-stage stroke	5	10	15	10	15	15	20	15	10	15
	Full stroke – First-stage stroke	5	10	15	10	15	15	20	15	10	15

Operating Range

Auto switch model	Bore size (mm)			
	32	40	50	63
D-A7□(H)(C) D-A80v(H)(C)	12	11	10	12
D-A79W	13	14	14	16
D-A9□(V)	9.5	9.5	9.5	11.5
D-F7□(V) D-J79(C) D-F7□W(V) D-F7BA(V) D-F7NTL	6	6	6	6.5
D-F79F	8	7	8	8.5
D-M9□(V)	4	4	4	5
D-M9□W(V) D-M9BAL	5.5	5.5	5.5	6.5
D-P5DW	—	5	5	5

* This is the guideline including a hysteresis, not granting warranty (dispersion approximately 30%). It may vary substantially depending on the ambient environment.

In addition to the models listed in "How to Order" the following auto switches can be mounted. Refer to Best Pneumatics catalogue for detailed specifications.

Auto switch type	Part No.	Electrical entry	Features	Applicable bore size
Solid state switch	D-F7NTL	Grommet (in-line)	With timer	ø32 to ø63

- * D-F7NTL is also available with pre-wired connector. For details, refer to Best Pneumatics catalogue.
- * Normally closed type (NC = b contact) solid state auto switches are also available (D-F9G, F9H). For details, refer to Best Pneumatics catalogue.

Series RZQ

Auto Switch Specifications

Auto Switch Common Specifications

Auto switch style	Reed switch	Solid state switch
Current leakage	None	3 wire: 100 mA or less, 2 wire: 0.8 mA or less
Operating time	1.2ms	1ms or less ^{Note2)}
Shock resistance	300 m/s ²	1000 m/s ²
Insulation resistance	50 M or more at 500MV DC (between lead wire and the case)	
Withstand voltage	1500V AC/min. ^{Note1)} (between lead wire and the case)	1000V AC/min. (between lead wire and the case)
Ambient temperature	-10 to 60C	
Protective construction	IEC529 Standard IP67, Waterproof construction (JISC0920)	

Note 1) Connector style (D-A73C/A80C) and A9/A9□V style: 1000V AC/min. (between lead wire and the case)

Note 2) Except solid state switch with timer (F7NTL) and **Auto switch for strong magnetic field resistance (D-P5DWL)**.

Lead Wire Length

Lead wire length indication

(Example) **D-M9P**L

Lead wire length

Nil	0.5 m
L	3 m
Z	5 m

Note 1) Applicable auto switch with 5 m lead wire "Z"

Reed switch: D-A73 (C)(H), D-A80C

Solid state switch: Manufactured upon receipt of order as standard.

Note 2) To designate solid state switches with flexible specifications, add "-61" after the lead wire length.

* Oil resistant flexible cable cord is used for D-M9□ as standard. There is no need to place the suffix -61 to the end of part number.

(Example) **D-M9PWVL**-61

Flexible specification

Auto Switch Hysteresis

The hysteresis is the difference between the position of the auto switch as it turns "on" and as it turns "off". A part of operating range (one side) includes this hysteresis.

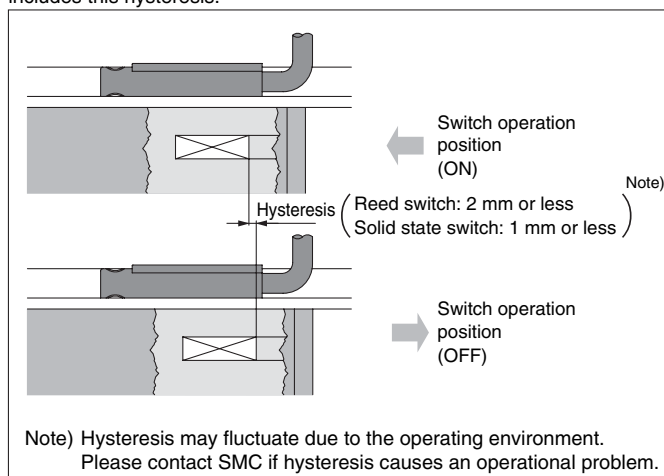

Contact Protection Boxes: CD-P11, CD-P12

<Applicable switch model>

The following auto switches are not incorporated with the contact protection box.

D-A7/A8, D-A7□H/A80H, D-A73C, A80C, D-A9/A9□V, and D-A79W type
Use an auto switch with a contact protection box in any case listed below. Unless using a contact protection box, the contact life may be shortened.

(Due to permanent energising conditions.)

D-A72(H) must be used with the contact protection box regardless of load styles and lead wire length.

- ① Operating load is an inductive load.
- ② The wiring length to load is 5m or longer.
- ③ The load voltage is 100 or 200 V AC.

Specifications

Part No.	CD-P11		CD-P12
Load voltage	100 VAC	200 VAC	24 VDC
Maximum load current	25 mA	12.5 mA	50 mA

* Lead wire length — Switch connection side 0.5 m
Load connection side 0.5 m



Internal Circuits

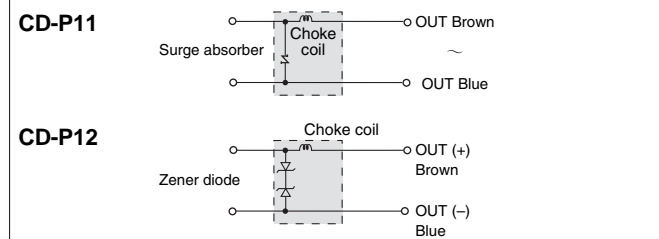

Dimension

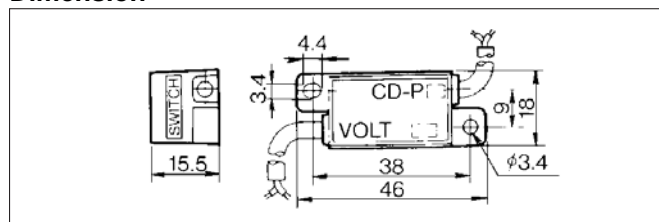

Connection

To connect a switch unit to a contact protection box, connect the lead wire from the side of the contact protection box marked SWITCH to the lead wire coming out of the switch unit. Keep the switch as close as possible to the contact protection box, with a lead wire length of no more than 1 metre.

Series RZQ Auto Switch Connections and Examples

Basic Wiring

Solid state 3-wire, NPN

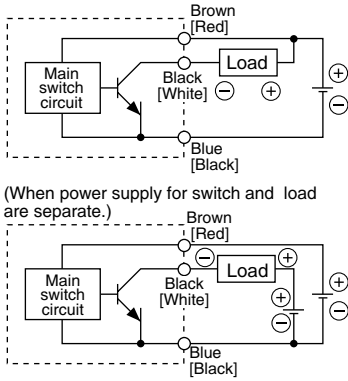

Solid state 3-wire, PNP

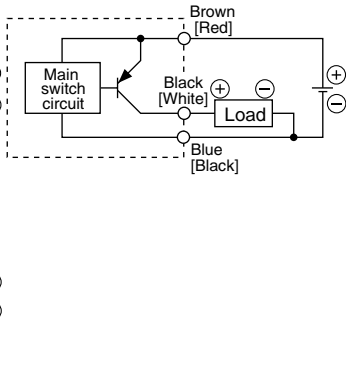

2-wire (Solid state)

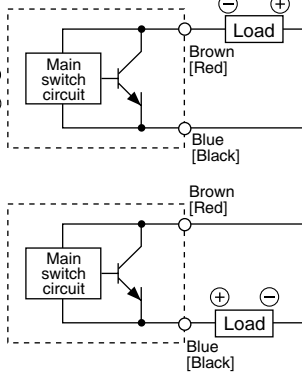

2-wire (Reed switch)

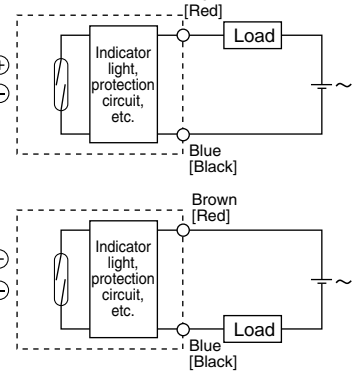

Examples of Connection to PLC

Sink input specifications

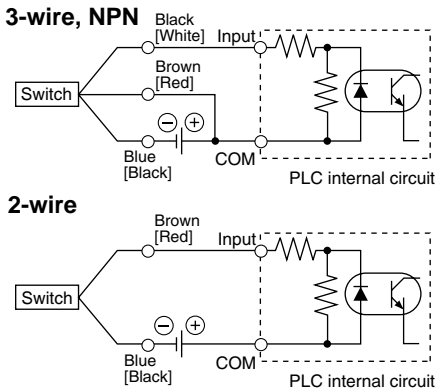

Source input specifications

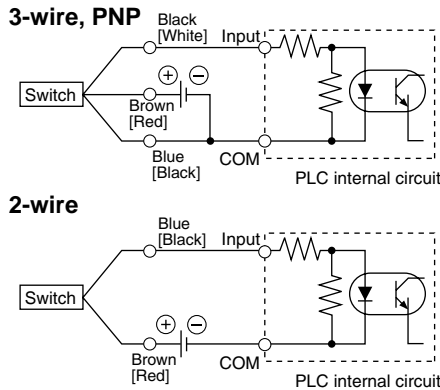

Connect according to the applicable PLC input specifications, as the connection method will vary depending on the PLC input specifications.

Connection Examples for AND (Series) and OR (Parallel)

3-wire AND connection for NPN output (using relays)

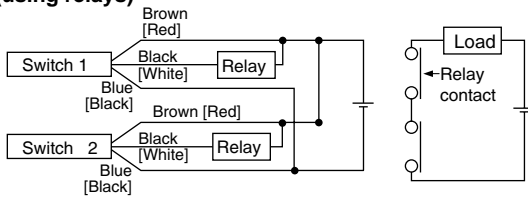

AND connection for NPN output (performed with switches only)

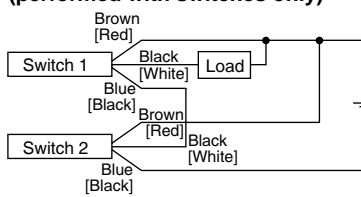

OR connection for NPN output

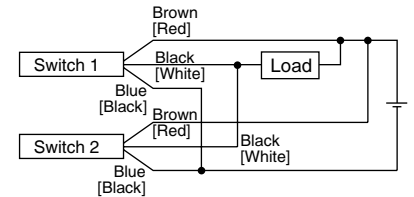

The indicator lights will light up when both switches are turned ON.

2-wire with 2 switches AND connection

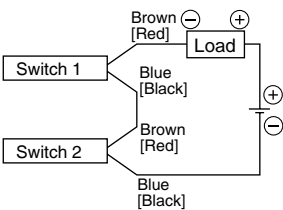

When two switches are connected in series, a load may malfunction because the load voltage will decline when in the ON state. The indicator lights will light up if both of the switches are in the ON state.

2-wire with 2 switches OR connection

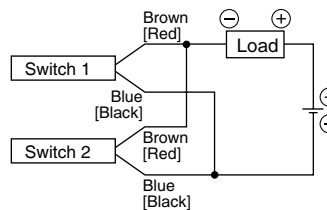

(Solid state)
When two switches are connected in parallel, malfunction may occur because the load voltage will increase when in the OFF state.

(Reed switch)
Because there is no current leakage, the load voltage will not increase when turned OFF. However, depending on the number of switches in the ON state, the indicator lights may sometimes get dark or not light up, because of dispersion and reduction of the current flowing to the switches.

$$\begin{aligned} \text{Load voltage at ON} &= \text{Power supply} - \frac{\text{Residual voltage}}{\text{voltage}} \times 2 \text{ pcs.} \\ &= 24\text{V} - 4\text{V} \times 2 \text{ pcs.} \\ &= 16\text{V} \end{aligned}$$

Example: Power supply is 24VDC
Voltage decline in switch is 4V

$$\begin{aligned} \text{Load voltage at OFF} &= \frac{\text{Leakage current}}{\text{current}} \times 2 \text{ pcs.} \times \frac{\text{Load impedance}}{\text{impedance}} \\ &= 1\text{mA} \times 2 \text{ pcs.} \times 3\text{k}\Omega \\ &= 6\text{V} \end{aligned}$$

Example: Load impedance is 3kΩ
Leakage current from switch is 1mA

Reed Switch/Direct Mounting Type D-A90(V)/D-A93(V)/D-A96(V)



For details about certified products conforming to international standards, visit us at www.smcworld.com.

Auto Switch Specifications

PLC: Abbreviation for Programmable Logic Controller

Grommet
Electrical entry direction: In-line



⚠ Caution

Operating Precautions

Fix the switch with the existing screw installed on the switch body. The switch may be damaged if a screw other than the one supplied, is used.

Auto Switch Internal Circuit

D-A90 (V)

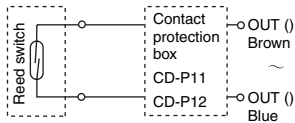

D-A93 (V)

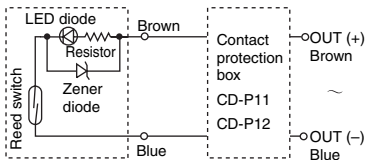

D-A96 (V)

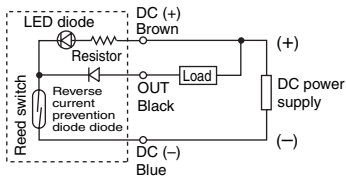

- Note) ① In a case where the operation load is an inductive load.
② In a case where the wiring load is greater than 5 m.
③ In a case where the load voltage is 100 VAC.

Please use the auto switch with a contact protection box any of the above mentioned cases. (For details about the contact protection box, refer to page 14.)

D-A90/D-A90V (without indicator light)			
Auto switch part no.	D-A90/D-A90V		
Applicable load	IC circuit, Relay, PLC		
Load voltage	24 V AC/DC or less	48 V AC/DC or less	100 V AC/DC or less
Maximum load current	50 mA	40 mA	20 mA
Contact protection circuit	None		
Internal resistance	1 Ω or less (including lead wire length of 3 m)		
D-A93/D-A93V/D-A96/D-A96V (with indicator light)			
Auto switch part no.	D-A93/D-A93V		D-A96/D-A96V
Applicable load	Relay, PLC		IC circuit
Load voltage	24 VDC	100 VAC	4 to 8 VDC
Load current range and max. load current	Note 3) 5 to 40 mA	5 to 20 mA	20 mA
Contact protection circuit	None		
Internal voltage drop	D-A93 — 2.4 V or less (to 20 mA)/3 V or less (to 40 mA) D-A93V — 2.7 V or less		0.8 V or less
Indicator light	Red LED lights when ON		

● Lead wires

D-A90(V)/D-A93(V) — Oilproof vinyl heavy insulation cable: $\phi 2.7$, 0.18 mm² x 2 cores (Brown, Blue), 0.5 m
D-A96(V) — Oilproof vinyl heavy insulation cable: $\phi 2.7$, 0.15 mm² x 3 cores (Brown, Black, Blue), 0.5 m

Note 1) Refer to page 14 for reed switch common specifications and lead wire length.

Note 2) Refer to page 14 for lead wire lengths.

Note 3) Under a 5 mA condition, the indicating light visibility becomes low and at a 2.5 mA condition, it may be unreadable. However, as long as the contact output is over a 1 mA condition, there will be no problem.

Weight Table

Unit: g

Model	D-A90	D-A90V	D-A93	D-A93V	D-A96	D-A96V
Lead wire length: 0.5 m	6	6	6	6	8	8
Lead wire length: 3 m	30	30	30	30	41	41

Dimensions

Unit: mm

D-A90/D-A93/D-A96

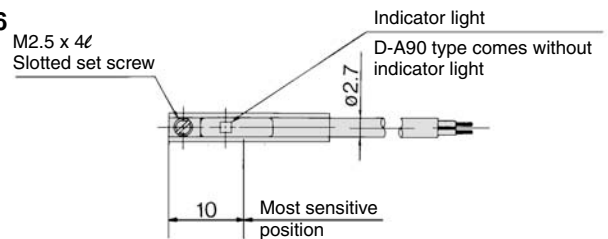

D-A90V/D-A93V/D-A96V

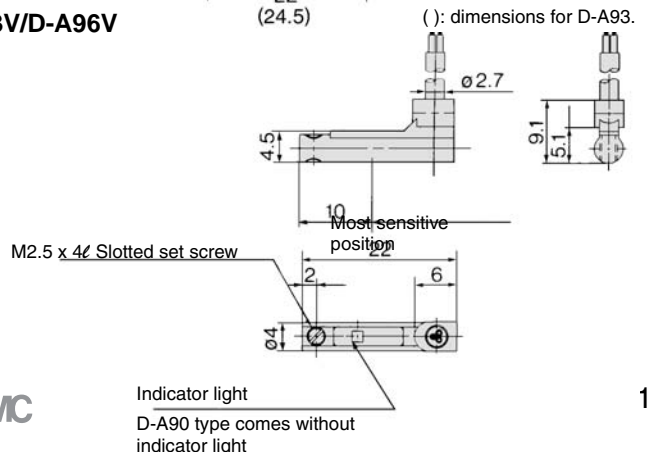

Solid State Switch/Direct Mounting Type D-M9N(V)/D-M9P(V)/D-M9B(V)



For details about certified products conforming to international standards, visit us at www.smcworld.com.

Auto Switch Specifications

PLC: Abbreviation of Programmable Logic Controller

D-M9□, D-M9□V (With indicator light)						
Auto switch part no.	D-M9N	D-M9NV	D-M9P	D-M9PV	D-M9B	D-M9BV
Electrical entry direction	In-line	Perpendicular	In-line	Perpendicular	In-line	Perpendicular
Wiring type	3-wire			2-wire		
Output type	NPN		PNP		—	
Applicable load	IC circuit, Relay, PLC				24 VDC relay, PLC	
Power supply voltage	5, 12, 24 VDC (4.5 to 28 V)					—
Current consumption	10 mA or less					—
Load voltage	28 VDC or less		—		24 VDC (10 to 28 VDC)	
Load current	40 mA or less				2.5 to 40 mA	
Internal voltage drop	0.8 V or less				4 V or less	
Leakage current	100 A or less at 24 VDC				0.8 mA or less	
Indicator light	Red LED lights when ON.					

● Lead wires

Oilproof vinyl heavy insulation cable: $\phi 2.7 \times 3.2$ ellipse, 0.15 mm²,

D-M9B(V) 0.15 mm² x 2 cores

D-M9N(V), D-M9P(V) 0.15 mm² x 3 cores

Note 1) Refer to page 14 for solid state switch common specifications.

Note 2) Refer to page 14 for lead wire lengths.

Grommet

- 2-wire load current is reduced (2.5 to 40 mA)
- Lead-free
- UL certified (style2844) lead cable is used.



⚠ Caution

Operating Precautions

Fix the switch with the existing screw installed on the switch body. The switch may be damaged if a screw other than the one supplied, is used.

Auto Switch Internal Circuit

D-M9N, D-M9NV

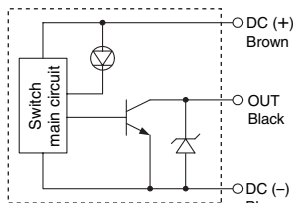

D-M9P, D-M9PV

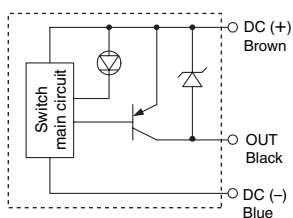

D-M9B, D-M9BV

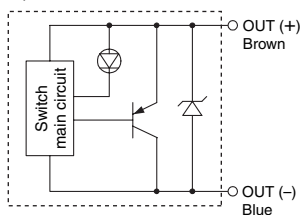

Weight Table

Unit: g

Auto switch part no.	D-M9N(V)	D-M9P(V)	D-M9B(V)
Lead wire length (m)	0.5	8	7
	3	41	38
	5	68	63

Dimensions

Unit: mm

D-M9□

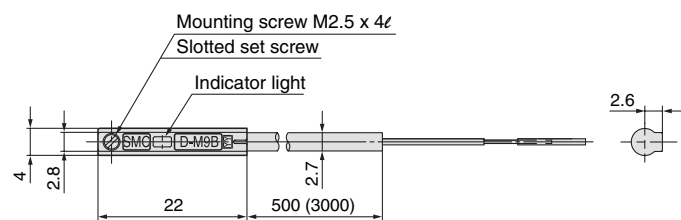
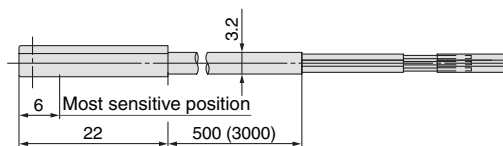

D-M9□V

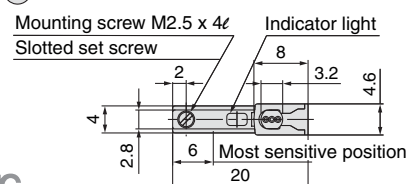
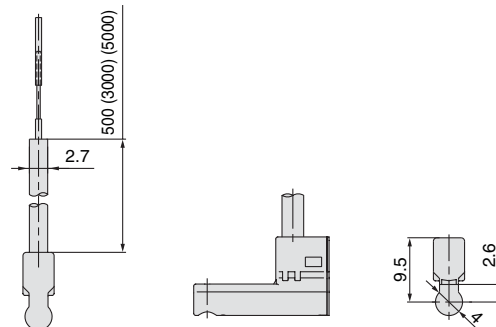

2-colour Indication Type, Solid State Switch/Direct Mounting Type D-F9NW(V)/D-F9PW(V)/D-F9BW(V)



For details about certified products conforming to international standards, visit us at www.smcworld.com.

Auto Switch Specifications

PLC: Abbreviation for Programmable Logic Controller

D-F9□W/D-F9□WV (with indicator light)						
Auto switch part no.	D-F9NW	D-F9NWV	D-F9PW	D-F9PWV	D-F9BW	D-F9BWV
Electrical entry direction	In-line	Perpendicular	In-line	Perpendicular	In-line	Perpendicular
Wiring type	3-wire			2-wire		
Output type	NPN		PNP		—	
Applicable load	IC circuit, Relay, PLC				24 VDC relay, PLC	
Power supply voltage	5, 12, 24 VDC (4.5 to 28 VDC)				—	
Current consumption	10 mA or less				—	
Load voltage	28 VDC or less		—		24 VDC (10 to 28 VDC)	
Load current	40 mA or less		80 mA or less		5 to 40 mA	
Internal voltage drop	1.5 V or less (0.8 V or less at 10 mA load current)		0.8 V or less		4 V or less	
Leakage current	100 A or less at 24 VDC				0.8 mA or less	
Indicator light	Operating position Red LED lights up Optimum operating position Green LED lights up					

Grommet



Caution

Operating Precautions

Fix the switch with the existing screw installed on the switch body. The switch may be damaged if a screw other than the one supplied, is used.

Auto Switch Internal Circuit

D-F9NW/F9NWV

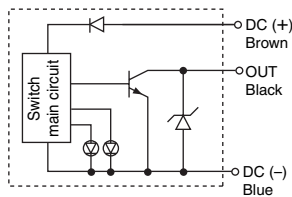

D-F9PW/F9PWV

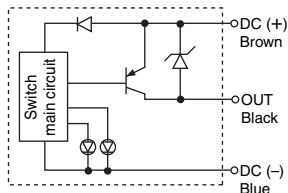

D-F9BW/F9BWV

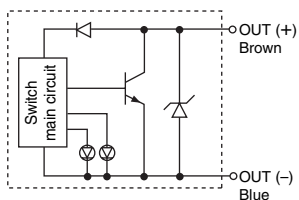

Indicator light/Display method

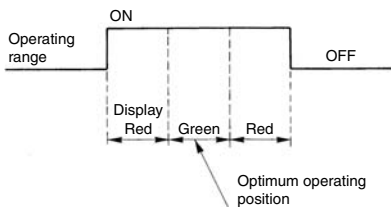

Lead wires

Oilproof vinyl heavy insulation cable: $\phi 2.7$, 0.15 mm² x 3 cores (Brown, Black Blue), 0.18 mm² x 2 cores (Brown, Blue), 0.5 mm

Note 1) Refer to page 14 for reed switch common specifications.

Note 2) Refer to page 14 for lead wire lengths.

Weight Table

Unit: g

Auto switch part no.	D-F9NW(V)	D-F9PW(V)	D-F9BW(V)
Lead wire length (m)			
0.5	7	7	7
3	34	34	32
5	56	56	52

Dimensions

Unit: mm

D-F9□W

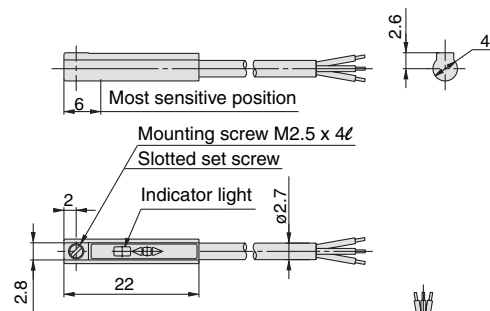

D-F9□WV

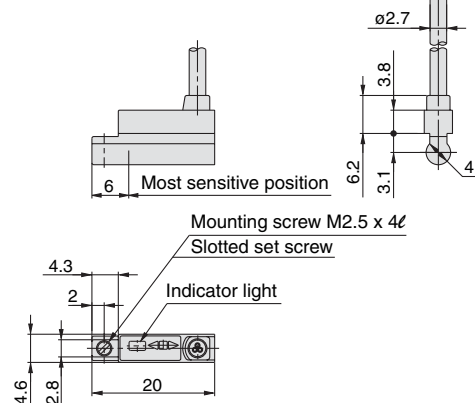

Water Resistant 2-colour Indication Type, Solid State Switch/Direct Mounting D-F9BAL



For details about certified products conforming to international standards, visit us at www.smcworld.com.

Auto Switch Specifications

PLC: Programmable Logic Controller

D-F9BAL (With indicator light)	
Auto switch model no.	D-F9BAL
Wiring type	2-wire
Output type	—
Application	24V DC relay, /PLC
Power voltage	—
Current consumption	—
Load voltage	24V DC (10 to 28V DC)
Load current	5 to 30mA
Internal voltage drop	5V
Current leakage	1mA at 24V DC
Indicator light	Operating point: Red light emitting diode Suitable operating point: Green light emitting diode

●Lead wires — Oilproof vinyl heavy insulation cable, $\phi 2.7$, 2 cores (Brown, Blue), 0.18mm², 0.5m

Note 1) Refer to page 14 for reed switch common specifications.

Note 2) Refer to page 14 for lead wire lengths.

Grommet

Water (coolant) resistant per-formance



Caution

Precautions

Consult SMC if using coolant liquid other than water based solution.

Weight Table

Unit: g

Auto switch part no.		D-F9BA
Lead wire length (m)	0.5	—
	3	37
	5	57

Auto Switch Internal Circuit

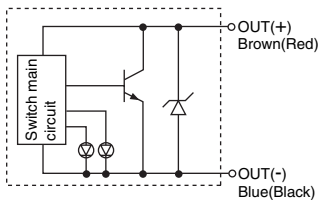

Indicator light/Display method

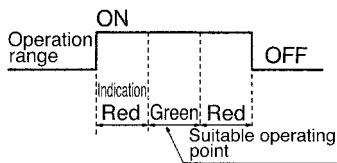

Dimensions

Unit: mm

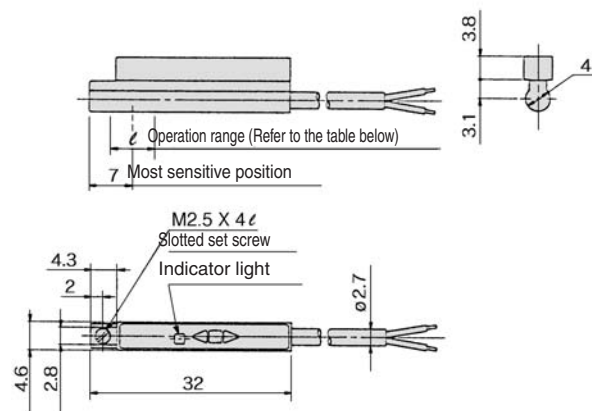





Series RZQ

Safety Instructions

These safety instructions are intended to prevent a hazardous situation and/or equipment damage. These instructions indicate the level of potential hazard by a label of "**Caution**", "**Warning**" or "**Danger**". To ensure safety, be sure to observe ISO 4414 Note 1), JIS B 8370 Note 2) and other safety practices.

 **Caution** : Operator error could result in injury or equipment damage.

 **Warning** : Operator error could result in serious injury or loss of life.

 **Danger** : In extreme conditions, there is a possible result of serious injury or loss of life.

Note 1) ISO 4414 : Pneumatic fluid power --General rules relating to systems

Note 2) JIS B 8370: Pneumatic system axiom

Warning

1. The compatibility of pneumatic equipment is the responsibility of the person who designs the pneumatic system or decides its specifications.

Since the products specified here are used in various operating conditions, their compatibility for the specific pneumatic system must be based on specifications or after analysis and/or tests to meet your specific requirements. The expected performance and safety assurance will be the responsibility of the person who has determined the compatibility of the system. This person should continuously review the suitability of all items specified. Referring to the latest catalogue information with a view to giving due consideration to any possibility of equipment failure when constructing a system.

2. Only trained personnel should operate pneumatically operated machinery and equipment.

Compressed air can be dangerous if handled incorrectly. Assembly, handling or repair of pneumatic systems should be performed by trained and experienced operators.

3. Do not service machinery/equipment or attempt to remove components until safety is confirmed.

1. Inspection and maintenance of machinery/equipment should only be performed after confirmation of safe locked-out control positions.
2. When equipment is to be removed, confirm the safety process as mentioned above. Cut the supply pressure for this equipment and exhaust all residual compressed air in the system.
3. Before machinery/equipment is restarted, take measures to prevent shooting-out of cylinder piston rod, etc. (Bleed air into the system gradually to create back pressure.)

4. Contact SMC if the product is to be used in any of the following conditions:

1. Conditions and environments beyond the given specifications, or if product is used outdoors.
2. Installation on equipment in conjunction with atomic energy, railway, air navigation, vehicles, medical equipment, food and beverages, recreation equipment, emergency stop circuits, press applications, or safety equipment.
3. An application which has the possibility of having negative effects on people, property, or animals, requiring special safety analysis.



Series RZQ Actuator Precautions 1

Be sure to read before handling.

Design

Warning

1. **There is a danger of sudden action by air cylinders if sliding parts of machinery are twisted, etc. and changes in forces occur.**

In such cases, human injury may occur; e.g., by catching hands or feet in the machinery, or damage to the machinery itself may occur. Conduct adjustment to ensure smooth movement of the machine and plan a design to avoid human injury.

2. **A protective cover is recommended to minimise the risk of human injury.**

If a driven object or moving parts of the cylinder pose a danger of personal injury, design the structure to avoid contact with the human body.

3. **Securely tighten all stationary parts and connected parts so that they will not become loose.**

When a cylinder operates at a high frequency or is installed where there is a lot of vibration, ensure that all parts remain secure.

4. **A deceleration circuit or shock absorber, etc., may be required.**

When a driven object is operated at a high speed or the load is heavy, the cylinder's cushion will not be sufficient to absorb the impact. Install a deceleration circuit to reduce the speed before cushioning, or install an external shock absorber to relieve the impact. In this case, the rigidity of the machinery should also be examined.

5. **Consider a possible drop in operating pressure due to a power outage, etc.**

When a cylinder is used in a clamping mechanism, there is a danger of work pieces dropping if there is a decrease in clamping force due to a drop in circuit pressure caused by a power outage, etc. Therefore, safety equipment should be installed to prevent damage to machinery and/or human injury. Suspension mechanisms and lifting devices also require consideration for drop prevention.

6. **Consider a possible loss of power source.**

Measures should be taken to protect against human injury and equipment damage in the event that there is a loss of power to equipment controlled by pneumatics, electricity or hydraulics, etc.

7. **Design circuitry to prevent sudden lurching of driven objects.**

When a cylinder is driven by an exhaust center type directional control valve or when it starts-up after residual pressure is exhausted from the circuit, etc., the piston and its driven object will shoot out at a high speed if pressure is applied to one side of the cylinder because of the absence of air pressure inside the cylinder. Therefore, equipment should be selected and circuits designed to prevent sudden shoot-outs because, there is a danger of human injury and/or damage to equipment when this occurs.

8. **Consider emergency stops.**

Design so that human injury and/or damage to machinery and equipment will not be caused when machinery is stopped by a safety device under abnormal conditions, a power outage or a manual emergency stop.

9. **Consider the action when operation is restarted after an emergency stop or abnormal stop.**

Design the machinery so that human injury or equipment damage will not occur upon restart of operation. When the cylinder has to be reset at the starting position, install manual safety equipment.

Selection

Warning

1. **Confirm the specifications.**

The products advertised in this catalogue are designed according to use in industrial compressed air systems. If the products are used in conditions where pressure, temperature, etc., are out of specifications, damage and/or malfunction may be caused. Do not use in these conditions. (Refer to specifications.)

Consult SMC if you use a fluid other than compressed air.

Caution

1. **Operate within the limits of the maximum usable stroke.**

The piston rod will be damaged if operated beyond the maximum stroke. Refer to the air cylinder model selection procedure for the maximum useable stroke.

2. **Operate the piston within a range such that collision damage will not occur at the stroke end.**

Operate within a range such that damage will not occur when the piston, having inertial force, stops by striking the cover at the stroke end. Refer to the cylinder model selection procedure for the range within which damage will not occur.

3. **Use a speed controller to adjust the cylinder drive speed, gradually increasing from a low speed to the desired speed setting.**

Mounting

Caution

1. **Be certain to match the rod shaft center with the direction of the load and movement when connecting.**

When not properly matched, problems may arise with the rod and tube, and damage may be caused due to friction on areas such as the inner tube surface, bushings, rod surface and seals.

2. **When an external guide is used, connect the rod end and the load in such a way that there is no interference at any point within the stroke.**

3. **Do not scratch or gouge the sliding parts of the cylinder tube or tube rod, etc., by striking or grasping them with other objects.**

Cylinder bores are manufactured to precise tolerances, so that even a slight deformation may cause malfunction. Also, scratches or gouges, etc., in the tube rod may lead to damaged seals and cause air leakage.

4. **Prevent the seizure of rotating parts.**

Prevent the seizure of rotating parts (pins, etc.) by applying grease.



Series RZQ Actuator Precautions 2

Be sure to read before handling.

Mounting

⚠ Caution

5. Do not use until you can verify that equipment can operate properly.

Verify correct mounting by suitable function and leakage inspections after compressed air and power are connected following mounting, maintenance or conversions.

6. Instruction manual

The product should be mounted and operated after thoroughly reading the manual and understanding its contents.

Keep the instruction manual where it can be referred to as needed.

Piping

⚠ Caution

1. Preparation before piping

Before piping is connected, it should be thoroughly blown out with air (flushing) or washed to remove chips, cutting oil and other debris from inside the pipe.

2. Wrapping of pipe tape

When screwing in pipes and fittings, etc., be certain that chips from the pipe threads and sealing material will not ingress inside the piping.

Also, when pipe tape is used, leave 1.5 to 2 thread ridges exposed at the end of the threads.

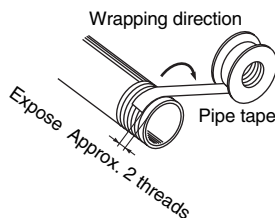

Lubrication

⚠ Caution

1. Lubrication of non-lube type cylinder

The cylinder is lubricated at the factory and can be used without any further lubrication.

Air Supply

⚠ Warning

1. Use clean air.

If compressed air includes chemicals, synthetic oils containing organic solvents, salt or corrosive gases, etc., it can cause damage or malfunction.

⚠ Caution

1. Install air filters.

Install air filters at the upstream side of valves. The filtration degree should be 5µm or finer.

Air Supply

2. Install an after cooler, air dryer or water separator (Drain Catch), etc.

Air that contains excessive moisture may cause malfunction of valves and other pneumatic equipment. To prevent this, install an after cooler, air dryer or water separator (Drain Catch).

3. Use the product within the specified range of fluid and ambient temperature.

Take measures to prevent freezing, since moisture in circuits will be frozen under 5°C, and this may cause damage to seals and lead to malfunction.

Refer to SMC's Best Pneumatics catalogue for further details on compressed air quality.

Operating Environment

⚠ Warning

1. Do not use in environments where there is a danger of corrosion.

2. In dusty locations or where water, oil, etc. splash on the equipment, take suitable measures to protect rod.

3. When using auto switches, do not operate in an environment with strong magnetic fields.

Maintenance

⚠ Warning

1. Maintenance should be performed according to the procedure indicated in the instruction manual.

If handled improperly, malfunction and damage of machinery or equipment may occur.

2. Removal of equipment, and supply/exhaust of compressed air

When equipment is removed, first take measures to prevent dropping of driven objects and run-away of equipment, etc. Then cut off the supply pressure and electric power, and exhaust all compressed air from the system.

When machinery is restarted, proceed with caution after confirming measures to prevent cylinder lurching.

⚠ Caution

1. Drain flushing

Remove drainage from air filters regularly.



Series RZQ

Auto Switch Precautions 1

Be sure to read before handling.

Design and Selection

Warning

1. Confirm the specifications.

Read the specifications carefully and use this product appropriately. The product may be damaged or malfunction if it is used outside the range of specifications for current load, voltage, temperature or impact.

2. Take precautions when multiple cylinders are used close together.

When two or more auto switch cylinders are lined up in close proximity with each other, magnetic field interference may cause the switches to malfunction. Maintain a minimum cylinder interval of 40 mm.

3. Pay attention to the length of time that a switch is ON at an intermediate stroke position.

When an auto switch is placed at an intermediate position of the stroke and a load is driven at the time the piston passes, the auto switch will operate, but if the speed is too great the operating time will be shortened and the load may not operate properly. The maximum detectable piston speed is:

$$V \text{ (mm/s)} = \frac{\text{Auto switch operating range (mm)}}{\text{Time load applied (ms)}} \times 1000$$

If the piston operates at a high speed, the load movement time can be extended with the use of an auto switch (D-F7NT) with built-in off-delay timer (approx. 200 ms).

4. Keep wiring as short as possible.

<Reed switches>

As the length of the wiring to a load becomes longer, the rush current at switching ON becomes greater, and this may shorten the product's life. (The switch will stay ON all the time.)

Use a contact protection box when the wire length is 5m or longer.

<Solid state switches>

Although wire length should not affect switch function, use a wire that is 100m or shorter.

5. Pay attention to the internal voltage drop of the switch.

<Reed switches>

- Switches with an indicator light (Except D-A76H, A96, A96V)
 - If auto switches are connected in series as shown below, take note that there will be a large voltage drop because of internal resistance in the light emitting diodes. (Refer to internal voltage drop in the auto switch specifications.)
[The voltage drop will be "n" times larger when "n" pieces of auto switches are connected.]
Even though the auto switch operates normally, the load may not operate.

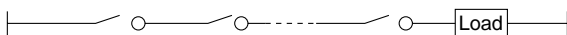

- In the same way, when operating under a specified voltage, although the auto switch may operate normally, the load may not operate. Therefore, the formula below should be satisfied after confirming the minimum operating voltage of the load.

$$\text{Supply voltage} - \text{Internal voltage drop of switch} > \text{Minimum operating voltage of load}$$

- If the internal resistance of a light emitting diode causes a problem, select a switch without an indicator light (Models D-A80, A80H, A90, A90V).

<Solid state switches>

- Generally, the internal voltage drop will be larger with a 2 wire solid state auto switch than with a reed switch. Take the same precautions as in 1).

Also, note that a 12VDC relay is not applicable.

6. Pay attention to leakage current.

<Solid state switches>

With a 2-wire solid state auto switch, current (leakage current) flows to the load to operate the internal circuit even when in the OFF state.

$$\text{Operating current of load (OFF condition)} > \text{Leakage current}$$

If the criteria given in the above formula are not met, it will not reset correctly (stays ON). Use a 3-wire switch if this specification will not be satisfied.

Moreover, leakage current flow to the load will be "n" times larger when "n" pieces of auto switches are connected in parallel.

7. Do not use a load that generates surge voltage.

<Reed switches>

When driving a load such as a relay that generates a surge voltage, use a contact protection box.

<Solid state switches>

Although a zener diode for surge protection is connected at the output side of a solid state auto switch, damage may still occur if the surge is applied repeatedly. When a load, such as a relay or solenoid which generates surge is directly driven, use a type of switch with a built-in surge absorbing element.

8. Cautions for use in an interlock circuit

When an auto switch is used for an interlock signal requiring high reliability, devise a double interlock system to avoid trouble by providing a mechanical protection function, or by also using another switch (sensor) together with the auto switch.

Also perform periodic maintenance and confirm proper operation.

9. Ensure sufficient clearance for maintenance activities.

When designing an application, be sure to allow sufficient clearance for maintenance and inspections.



Series RZQ

Auto Switch Precautions 2

Be sure to read before handling.

Mounting and Adjustment

Warning

1. Do not drop or bump.

Do not drop, bump or apply excessive impacts (300m/s² or more for reed switches and 1000m/s² or more for solid state switches) while handling. Although the body of the switch may not be damaged, the inside of the switch could be damaged and cause malfunction.

2. Do not carry a cylinder by the auto switch lead wires.

Never carry a cylinder by its lead wires. This may not only cause broken lead wires, but it may cause internal elements of the switch to be damaged by the stress.

3. Mount switches using the proper tightening torque.

If a switch is tightened beyond the range of tightening torque, the mounting screws or switch may be damaged.

On the other hand, tightening below the range of tightening torque may allow the switch to slip out of position. (Refer to page 13 for switch mounting and tightening torque.)

4. Mount a switch at the center of the operating range.

Adjust the mounting position of an auto switch so that the piston stops at the center of the operating range (the range in which the switch is ON). (The mounting position shown in the catalog indicates the optimum position at the stroke end.) If mounted at the end of the operating range (around the borderline of ON and OFF), operation will be unstable.

<D-M9□>

When the D-M9 auto switch is used to replace old series auto switch, it may not activate depending on operating condition because of its shorter operating range.

Such as

- Application where the stop position of actuator may vary and exceed the operating range of the auto switch, for example, pushing, pressing, clamping operation, etc.
- Application where the auto switch is used for detecting an intermediate stop position of the actuator. (In this case the detecting time will be reduced.)

In these applications, please set the auto switch to the center of the required detecting range.

Caution

1. Fix the switch with the appropriate screw installed on the switch body. The switch may be damaged if other screws are used.

Wiring

Warning

1. Avoid repeatedly bending or stretching lead wires.

Broken lead wires will result from repeatedly applying bending stress or stretching force to the lead wires.

2. Be sure to connect the load before power is applied.

<2-wire type>

If the power is turned ON when an auto switch is not connected to a load, the switch will be instantly damaged because of excess current.

Wiring

Warning

3. Confirm proper insulation of wiring.

Be certain that there is no faulty wiring insulation (contact with other circuits, ground fault, improper insulation between terminals, etc.). Damage may occur due to excess current flow into a switch.

4. Do not wire with power lines or high voltage lines.

Wire separately from power lines or high voltage lines, avoiding parallel wiring or wiring in the same conduit with these lines. Control circuits containing auto switches may malfunction due to noise from these other lines.

5. Do not allow short circuit of loads.

<Reed switches>

If the power is turned ON with a load in a short circuited condition, the switch will be instantly damaged because of excess current flow into the switch.

<Solid state switches>

D-M9□(V) and all models of PNP output type switches do not have built-in short circuit protection circuits.

Note that if a load is short circuited, the switch will be instantly damaged as in the case of reed switches.

- * Take special care to avoid reverse wiring with the brown (red) power supply line and the black (white) output line on 3-wire type switches.

6. Avoid incorrect wiring.

<Reed switches>

A 24VDC switch with indicator light has polarity. The brown (red) lead wire is (+), and the blue (black) lead wire is (-).

- 1) If connections are reversed, a switch will operate, however, the light emitting diode will not light up.

Also note that a current larger than that specified will damage a light emitting diode and it will no longer operate.

Applicable models: D-A73, A73H, A73C type
D-A93, A93V type

- 2) Special precautions must be taken in case of a 2-colour display auto switch (D-A79W) because if connections are reversed, the switch will stay in an ON state.

<Solid state switches>

- 1) If connections are reversed on a 2-wire type switch, the switch will not be damaged if protected by a protection circuit, but the switch will always stay in an ON state. However, it is still necessary to avoid reversed connections, since the switch could be damaged if a load short circuits in this condition.

- *2) If connections are reversed (power supply line + and power supply line -) on a 3-wire type switch, the switch will be protected by a protection circuit. However, if the power supply line (+) is connected to the blue (black) wire and the power supply line (-) is connected to the black (white) wire, the switch will be damaged.

<D-M9□>

D-M9□ does not have built-in short circuit protection circuit. Be aware that if the power supply connection is reversed (e.g. (+) power supply wire and (-) power supply wire connection is reversed), the switch will be damaged.



Series RZQ Auto Switch Precautions 3

Be sure to read before handling.

Wiring

* Lead wire colour changes

Lead wire colours of SMC switches and related products have been changed in order to meet NECA (Nippon Electric Control Equipment Industries Association) Standard 0402 for production beginning September, 1996 and thereafter. Please refer to the tables provided. Special care should be taken regarding wire polarity during the time that the old colours still coexist with the new colours.

2-wire

	Old	New
Output (+)	Red	Brown
Output (-)	Black	Blue

Solid state with diagnostic output

	Old	New
Power supply	Red	Brown
GND	Black	Blue
Output	White	Black
Diagnostic output	Yellow	Orange

3-wire

	Old	New
Power supply	Red	Brown
GND	Black	Blue
Output	White	Black

Solid state with latch type diagnostic output

	Old	New
Power supply	Red	Brown
GND	Black	Blue
Output	White	Black
Latch type diagnostic output	Yellow	Orange

⚠ Caution

- When the cable sheath is stripped, confirm the stripping direction. The insulator may be split or damaged depending on the direction. (D-M9□ only)

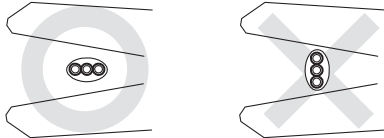

Recommended tool

Manufacturer	Model name	Model no.
VESSEL	Wire stripper	No 3000G
TOKYO IDEAL CO., LTD	Strip master	45-089

* Stripper for a round cable (ø2.0) can be used for a 2-wire type cable.

Operating Environment

⚠ Warning

- Never use in an atmosphere of explosive gases.**
The structure of auto switches is not intended to prevent explosion. Never use in an atmosphere with an explosive gas since this may cause a serious explosion.
- Do not use in an area where a magnetic field is generated.**
Auto switches will malfunction or magnets inside cylinders will become demagnetised. (Consult SMC regarding the availability of a magnetic field resistant auto switch.)
- Do not use in an environment where the auto switch will be continually exposed to water.**
Although switches satisfy IEC standard IP67 construction (JIS C 0920: watertight structure), do not use switches in applications where continually exposed to water splash or spray. Poor insulation or swelling of the potting resin inside switches may cause malfunction.

Operating Environment

⚠ Warning

- Do not use in an environment with oil or chemicals.**

Consult SMC if auto switches will be used in an environment with coolant, cleaning solvent, various oils or chemicals. If auto switches are used under these conditions for even a short time, they may be adversely affected by improper insulation, malfunction due to swelling of the potting resin, or hardening of the lead wires.

- Do not use in an environment with temperature cycles.**

Consult SMC if switches are used where there are temperature cycles other than normal temperature changes, as there may be adverse effects inside the switches.

- Do not use in an environment where there is excessive impact shock.**

<Reed switches>

When excessive impact (300m/s² or more) is applied to a reed switch during operation, the contact point will malfunction and generate or cut off a signal momentarily (1ms or less). Consult SMC regarding the need to use a solid state switch depending upon the environment.

- Do not use in an area where surges are generated.**

<Solid state switches>

When there are units (solenoid type lifter, high frequency induction furnace, motor, etc.) which generate a large amount of surge in the area around cylinders with solid state auto switches, this may cause deterioration or damage to the switch. Avoid sources of surge generation and disorganised lines.

- Avoid accumulation of iron waste or close contact with magnetic substances.**

When a large amount of iron waste such as machining chips or spatter is accumulated, or a magnetic substance (something attracted by a magnet) is brought into close proximity with an auto switch cylinder, it may cause the auto switch to malfunction due to a loss of the magnetic force inside the cylinder.

Maintenance

⚠ Warning

- Perform the following maintenance periodically in order to prevent possible danger due to unexpected auto switch malfunction.**
 - Secure and tighten switch mounting screws.
If screws become loose or the mounting position is dislocated, retighten them after readjusting the mounting position.
 - Confirm that there is no damage to lead wires.
To prevent faulty insulation, replace switches or repair lead wires, etc., if damage is discovered.
 - Confirm the lighting of the green light on the 2 colour indicator type switch.
Confirm that the green LED is ON when stopped at the set position. If the red LED is ON when stopped at the set position, the mounting position is not appropriate. Readjust the mounting

Other

⚠ Warning

- Consult SMC concerning water resistance, elasticity of lead wires, and usage at welding sites, etc.**



EUROPEAN SUBSIDIARIES:



Austria

SMC Pneumatik GmbH (Austria).
Girakstrasse 8, A-2100 Korneuburg
Phone: +43 2262-62280, Fax: +43 2262-62285
E-mail: office@smc.at
http://www.smc.at



France

SMC Pneumatique, S.A.
1, Boulevard de Strasbourg, Parc Gustave Eiffel
Bussy Saint Georges F-77607 Marne La Vallée Cedex 3
Phone: +33 (0)1-6476 1000, Fax: +33 (0)1-6476 1010
E-mail: contact@smc-france.fr
http://www.smc-france.fr



Netherlands

SMC Pneumatics BV
De Ruyterkade 120, NL-1011 AB Amsterdam
Phone: +31 (0)20-5318888, Fax: +31 (0)20-5318880
E-mail: info@smcpneumatics.nl
http://www.smcpneumatics.nl



Spain

SMC España, S.A.
Zuazobidea 14, 01015 Vitoria
Phone: +34 945-184 100, Fax: +34 945-184 124
E-mail: post@smc.smces.es
http://www.smces.es



Belgium

SMC Pneumatics N.V./S.A.
Nijverheidsstraat 20, B-2160 Wommelgem
Phone: +32 (0)3-355-1464, Fax: +32 (0)3-355-1466
E-mail: post@smcpneumatics.be
http://www.smcpneumatics.be



Germany

SMC Pneumatik GmbH
Boschring 13-15, D-63329 Egelsbach
Phone: +49 (0)6103-4020, Fax: +49 (0)6103-402139
E-mail: info@smc-pneumatik.de
http://www.smc-pneumatik.de



Norway

SMC Pneumatics Norway A/S
Vollsveien 13 C, Granfos Næringspark N-1366 Lysaker
Tel: +47 67 12 90 20, Fax: +47 67 12 90 21
E-mail: post@smc-norge.no
http://www.smc-norge.no



Sweden

SMC Pneumatics Sweden AB
Ekhagsvägen 29-31, S-141 71 Huddinge
Phone: +46 (0)8-603 12 00, Fax: +46 (0)8-603 12 90
E-mail: post@smcpneumatics.se
http://www.smc.nu



Bulgaria

SMC Industrial Automation Bulgaria EOOD
16 kliment Ohridski Blvd., fl.13 BG-1756 Sofia
Phone: +359 2 9744492, Fax: +359 2 9744519
E-mail: office@smc.bg
http://www.smc.bg



Greece

S. Parianopoulos S.A.
7, Konstantinoupoleos Street, GR-11855 Athens
Phone: +30 (0)1-3426076, Fax: +30 (0)1-3455578
E-mail: parianos@hol.gr
http://www.smceu.com



Poland

SMC Industrial Automation Polska Sp.z.o.o.
ul. Konstruktorska 11A, PL-02-673 Warszawa,
Phone: +48 22 548 5085, Fax: +48 22 548 5087
E-mail: office@smc.pl
http://www.smceu.pl



Switzerland

SMC Pneumatik AG
Dorfstrasse 7, CH-8484 Weisslingen
Phone: +41 (0)52-396-3131, Fax: +41 (0)52-396-3191
E-mail: info@smc.ch
http://www.smc.ch



Croatia

SMC Industrijska automatika d.o.o.
Cromerac 12, 10000 ZAGREB
Phone: +385 1 377 66 74, Fax: +385 1 377 66 74
E-mail: office@smc.hr
http://www.smceu.com



Hungary

SMC Hungary Ipari Automatizálási Kft.
Budafoki út 107-113, H-1117 Budapest
Phone: +36 1 371 1343, Fax: +36 1 371 1344
E-mail: office@smc-automation.hu
http://www.smc-automation.hu



Portugal

SMC Sucursal Portugal, S.A.
Rua de Engº Ferreira Dias 452, 4100-246 Porto
Phone: +351 22-610-89-22, Fax: +351 22-610-89-36
E-mail: postpt@smc.smces.es
http://www.smces.es



Turkey

Entek Pnömatik San. ve Tic Ltd. Sti.
Perpa Tic. Merkezi Kat: 11 No: 1625, TR-80270 Okmeydanı Istanbul
Phone: +90 (0)212-221-1512, Fax: +90 (0)212-221-1519
E-mail: smc-entek@entek.com.tr
http://www.entek.com.tr



Czech Republic

SMC Industrial Automation CZ s.r.o.
Hudcova 78a, CZ-61200 Brno
Phone: +420 5 414 24611, Fax: +420 5 412 18034
E-mail: office@smc.cz
http://www.smc.cz



Ireland

SMC Pneumatics (Ireland) Ltd.
2002 Citywest Business Campus, Naas Road, Saggart, Co. Dublin
Phone: +353 (0)1-403 9000, Fax: +353 (0)1-464-0500
E-mail: sales@smcpneumatics.ie
http://www.smcpneumatics.ie



Romania

SMC Romania srl
Str Frunzei 29, Sector 2, Bucharest
Phone: +40 213205111, Fax: +40 213261489
E-mail: smcromania@smcromania.ro
http://www.smcromania.ro



UK

SMC Pneumatics (UK) Ltd
Vincent Avenue, Crownhill, Milton Keynes, MK8 0AN
Phone: +44 (0)800 1382930 Fax: +44 (0)1908-555064
E-mail: sales@smcpneumatics.co.uk
http://www.smcpneumatics.co.uk



Denmark

SMC Pneumatik A/S
Knudsminde 4B, DK-8300 Odder
Phone: +45 70252900, Fax: +45 70252901
E-mail: smc@smc-pneumatik.dk
http://www.smcdk.com



Italy

SMC Italia S.p.A
Via Garibaldi 62, I-20061 Carugate, (Milano)
Phone: +39 (0)2-92711, Fax: +39 (0)2-9271365
E-mail: mailbox@smcitalia.it
http://www.smcitalia.it



Russia

SMC Pneumatik LLC.
4B Sverdlovskaja nab, St. Petersburg 195009
Phone: +812 718 5445, Fax: +812 718 5449
E-mail: info@smc-pneumatik.ru
http://www.smc-pneumatik.ru



Estonia

SMC Pneumatics Estonia OÜ
Laki 12-101, 106 21 Tallinn
Phone: +372 (0)6 593540, Fax: +372 (0)6 593541
E-mail: smc@smcpneumatics.ee
http://www.smcpneumatics.ee



Latvia

SMC Pneumatics Latvia SIA
Smerla 1-705, Riga LV-1006, Latvia
Phone: +371 781-77-00, Fax: +371 781-77-01
E-mail: info@smclv.lv
http://www.smclv.lv



Slovakia

SMC Priemyselna Automatizacia, s.r.o.
Námestie Martina Benku 10, SK-81107 Bratislava
Phone: +421 2 444 56725, Fax: +421 2 444 56028
E-mail: office@smc.sk
http://www.smc.sk



Finland

SMC Pneumatics Finland OY
PL72, Tiistinniityntie 4, SF-02031 ESPOO
Phone: +358 207 513513, Fax: +358 207 513595
E-mail: smc@smc.fi
http://www.smc.fi



Lithuania

SMC Pneumatics Lietuva, UAB
Savanoriu pr. 180, LT-01354 Vilnius, Lithuania
Phone: +370 5 264 81 26, Fax: +370 5 264 81 26



Slovenia

SMC industrijska Avtomatika d.o.o.
Grajski trg 15, SLO-8360 Zuzemberk
Phone: +386 738 85240 Fax: +386 738 85249
E-mail: office@smc-ind-avtom.si
http://www.smc-ind-avtom.si



OTHER SUBSIDIARIES WORLDWIDE:

ARGENTINA, AUSTRALIA, BOLIVIA, BRASIL, CANADA, CHILE,
CHINA, HONG KONG, INDIA, INDONESIA, MALAYSIA, MEXICO,
NEW ZEALAND, PHILIPPINES, SINGAPORE, SOUTH KOREA,
TAIWAN, THAILAND, USA, VENEZUELA

<http://www.smceu.com>
<http://www.smcworld.com>