



Contact our sales office for delivery dates and prices since this is a special model.

SP147X-031E-B
RP:TR

SMC P.G.Information (Specialized Product)

SMC Corporation
4-14-1, SOTO-KANDA,
CHIYODA-KU,
101-0021, JAPAN
URL: <http://www.smcworld.com>

Electric Stopper Cylinder / LEBQ40-X31 Series

Usable in stopper applications in conveyor lines without an air source!

■ Features

● **ON-OFF control only (no controller)**

- ⇒ Simple setup and reduced wiring work-hours
- ⇒ No need of controller installation space

● Equipped with an easy-to-maintain shock absorber

- ⇒ The shock absorber incorporated in the lever type is adjustment-free and easy-to-maintain
- ⇒ The drag value is changeable with the built-in lever adjustment bolt

● **Holding power at lowered-end 4.8W**

* Inrush power 48W

● **Maximum weight of transferred object**

Size	● Max. weight of transferred object (kg)
40	70

* Friction coefficient $\mu = 0.1$

● **Maximum speed of transferred object**

30m/min



● **Mounting compatible with air cylinder (Heavy duty stopper cylinder/RSQA40)**

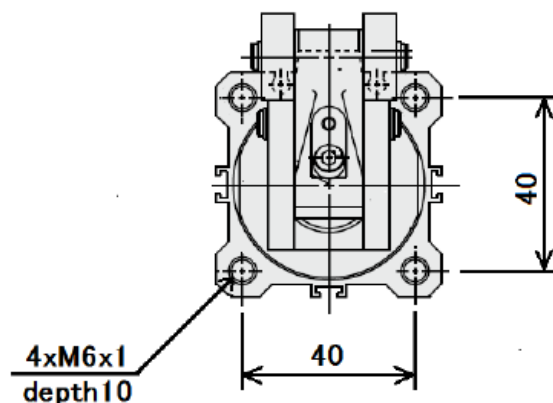

* Above drawing shows RSQA40.

● **Easy replacement of shock absorbers**

Replaceable just by loosening the set screw

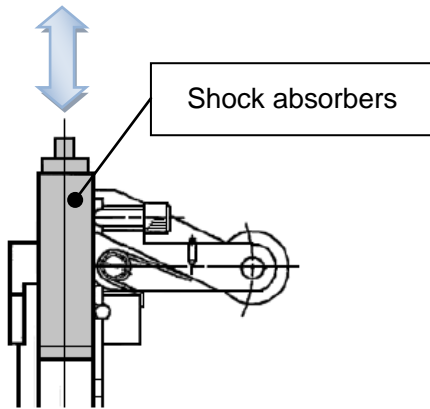

● **The roller can be selected from two materials to suit the application. (Resin, Carbon steel)**

【Roller materials】
 ・Resin
 ・Carbon steel

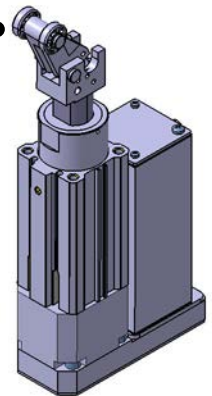

● **Can be mounted to compact auto switches. (D-M9□)**

The compact auto switch can be mounted directly to the round switch mounting groove.

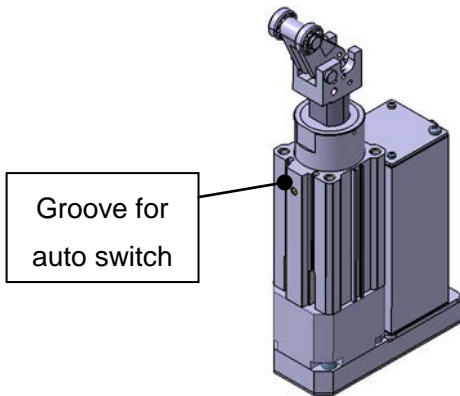

● **Better handling and visibility of the lock Mechanism (Option)**

The shape of the lock is changed. Easy to unlock manually, and instantly see whether it is locked.



● **With lock mechanism (Option)**

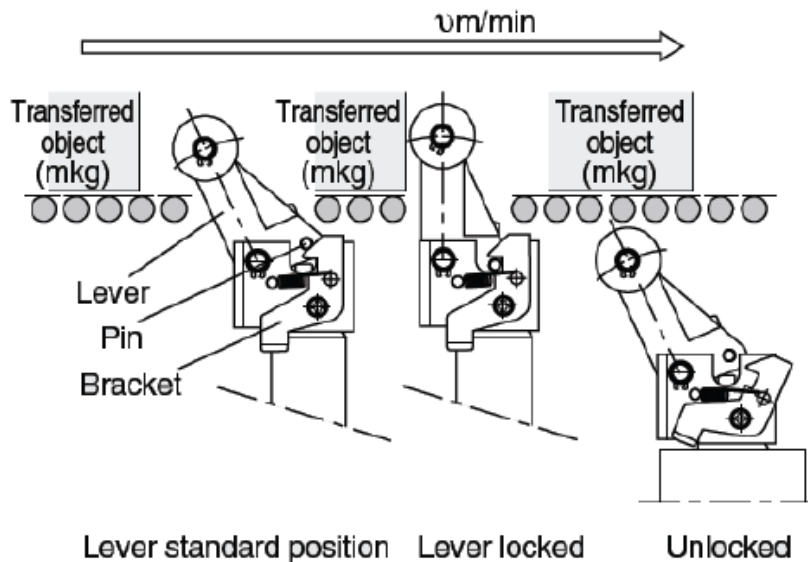

Operating principles

When de-energized (power OFF), raised-end is held with spring force only (operation 1) When energized (power ON), the roller starts to descend powered by the motor and by the coil. (operation 2) After the roller reaches the retracted end, the motor stops automatically and it is held by the solenoid force only (operation 3). When power is OFF, it starts to rise with spring force (operation 4).

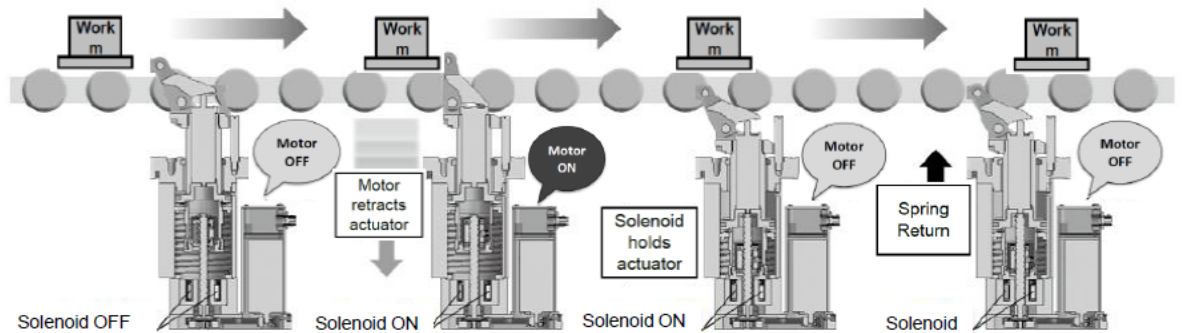

	Operation 1. Holding raised-end	Operation 2. Start descending	Operation 3. Holding lowered-end	Operation 4. Start rising
Power	OFF	ON	ON	OFF
Motor	OFF	ON	OFF	OFF
Solenoid	OFF	ON	ON	OFF
Power consumption (W)	48	4.8		

Model Selection

Lever Type (With shock absorber)

Friction coefficient $\mu = 0$ Graph (1)

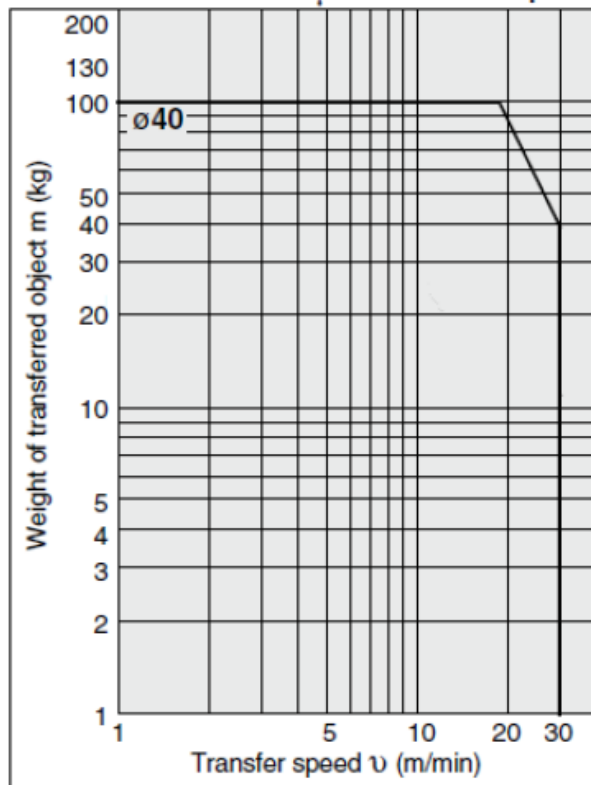

Lever Type (With shock absorber)

Friction coefficient $\mu = 0.1$ Graph (2)

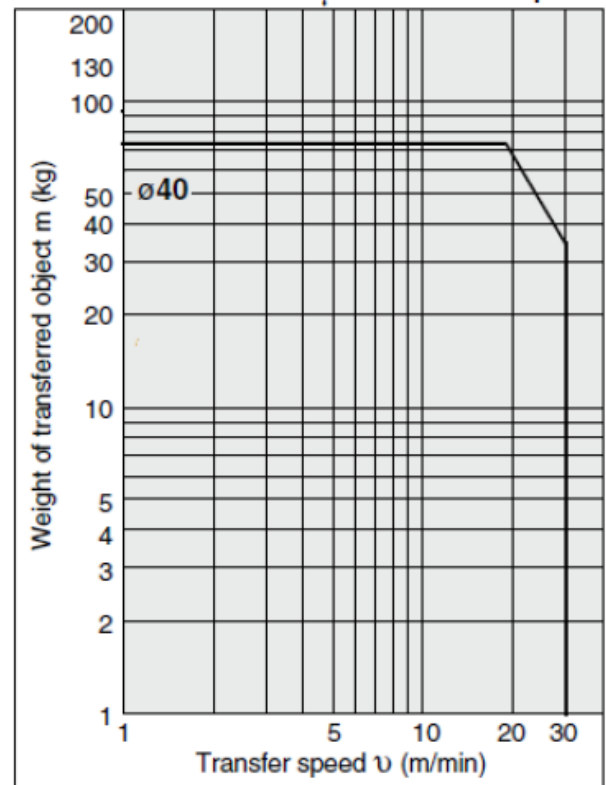

* Lever-type weight of transferred object and transfer speed graphs (graphs (1) and (2)) show the values at room temperature (20 to 25°C).

How to Order

LEBQ 40 E K - 20 T - X31

① ② ③ ④ ⑤ ⑥ ⑦

① Size

40

③ Lead (mm)

K	Basick
---	--------

②

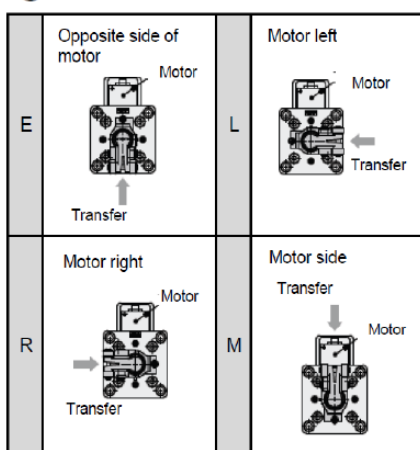

④ Stroke (mm)

20	20
----	----

⑤ Action

T	Single acting/spring extend
---	-----------------------------

⑥ Roller material

Nil	Resin
M	Carbon steel

⑦ Rod end shape

B	Lever with built-in shock absorber (energy absorbing adjustable)	Without
C		With cancel cap
D		With lock mechanism
E		With lock + cancel cap

Specifications

Actuator specification	Model	LEBQ40		
	Stroke [mm]	20		
	Installation orientation	Vertical (extending direction: top)		
	Maximum weight of transferred object [kg] ^{Note 1)}	$\mu=0$	100	
		$\mu=0.1$	70	
	Rising (extending operation) time [sec]	1 or less (At 20°C)		
	Descending (retracting operation) [sec]	1 or less (No lateral load, At 20°C)		
	Action	Single acting / Spring extend		
	Rod end configuration	Lever with built-in shock absorber		
	Actuation type	Ball screw + Belt		
	Operating frequency [c.p.m]	3 or less		
	Operating temp. range [°C]	5 to 40		
	Operating humidity range [%RH]	90 or less (No freezing)		
Weight [kg]	2.6 (Without option)			
Electric specifications	Motor size	φ38		
	Motor type	DC Motor		
	Rated voltage [V] ^{Note 3)}	24 VDC+/-10%		
	Starting power [W]	48		
	Holding power at lowered-end [W]	4.8		

Note 1) Please confirm the RSQ40 series for the relation between the weight of the transferred object and the speed of the transferred object.

Note 2) Please perform actuator retraction when the conveyor is stopped.

Note 3) Beware of inrush current of approx. 40A when the power supply is turned on.

Choose the equipment used when the power supply is turned such as relay considering the inrush current.

Construction

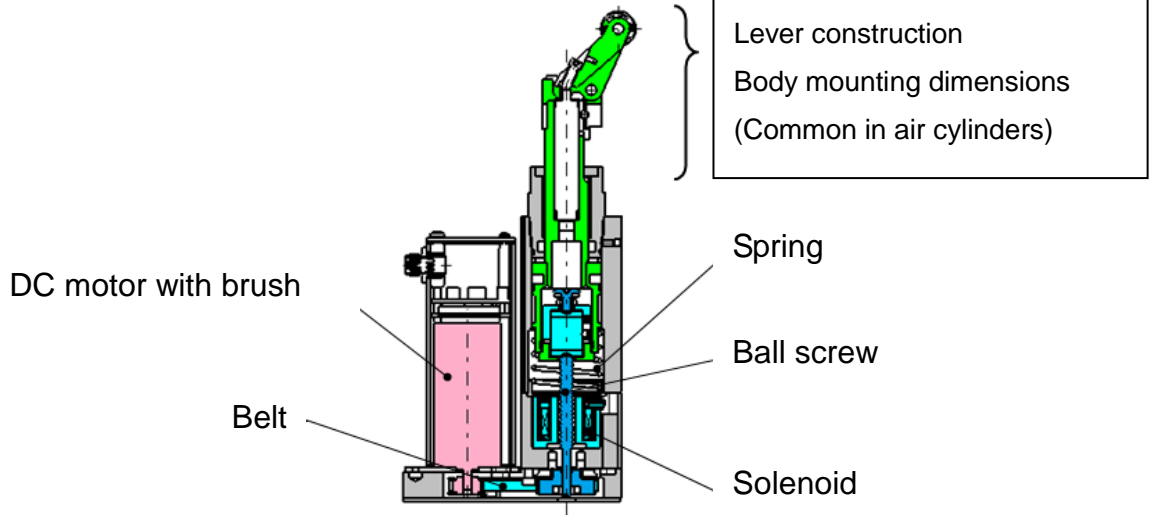

Dimensions

[mm]

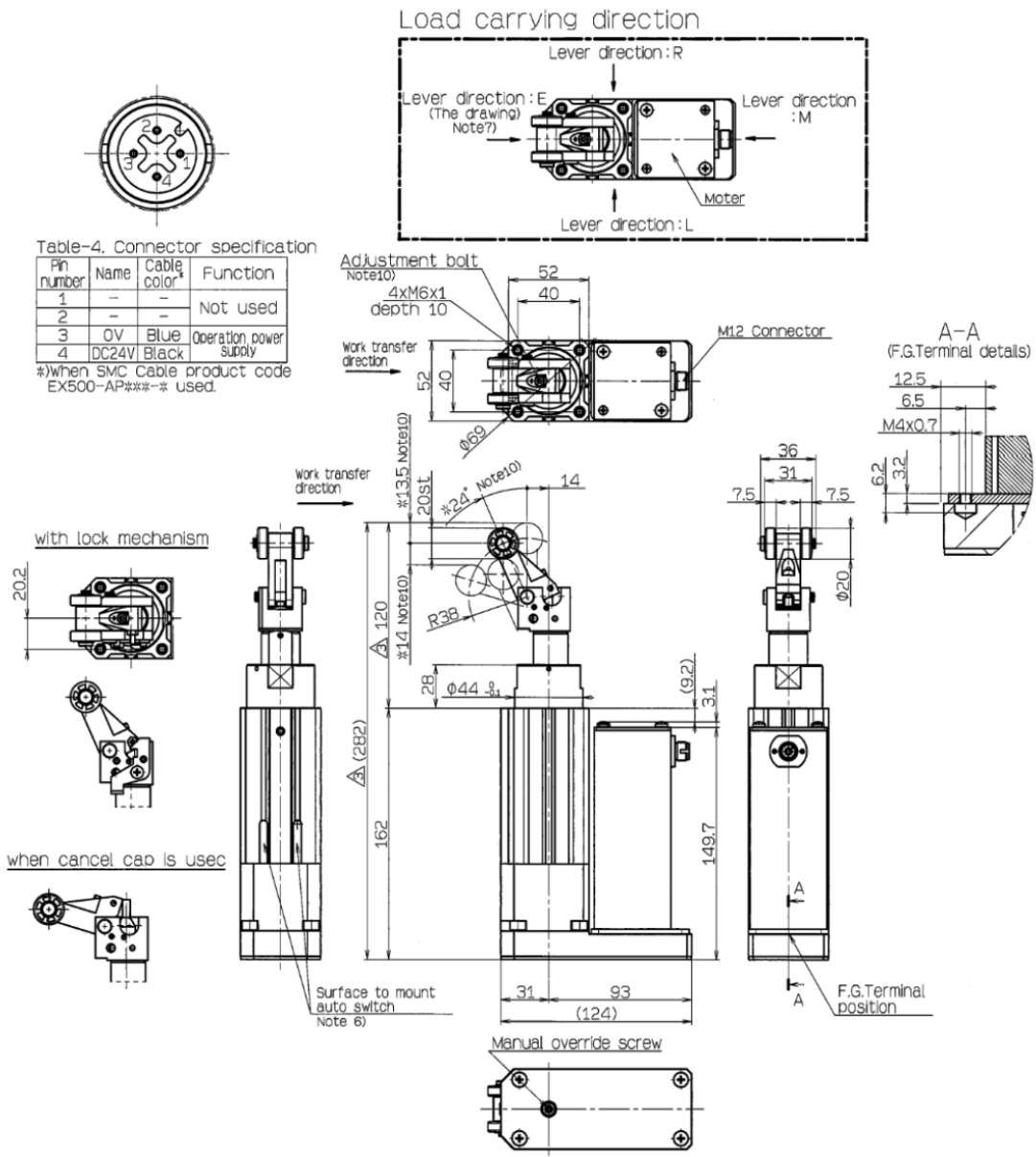

Table-4. Connector specification

Pin number	Name	Cable color*	Function
1	-	-	Not used
2	-	-	Not used
3	OV	Blue	Operation power supply
4	DC24V	Black	Supply

*)when SMC Cable product code EX500-AP***-# used.

* The lever direction of this drawing is opposite the motor side: E type

* The above drawing indicates the dimensions when the adjustment bolt is on the down end (when energy absorption is at its maximum) Regarding the dimensions with * marking, the values changes as the adjustment bolt goes up.

* 24° ⇒ 16° * 13.5 ⇒ 11.5 * 14 ⇒ 16

Auto Switch mounting

Auto switch proper mounting position (Detection at Stroke End)

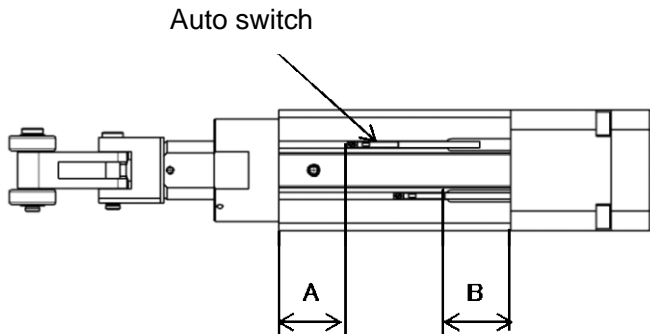

Auto switch proper mounting position (mm)

	Auto switch model			
	D-M9□ D-M9□W		D-M9□V D-M9□WV	
	A	B	A	B
LEBQ40	29.6	28.4	29.6	30.4

Note) Adjust the auto switch after confirming the Operating conditions in the actual setting

Auto switch mounting dimensions

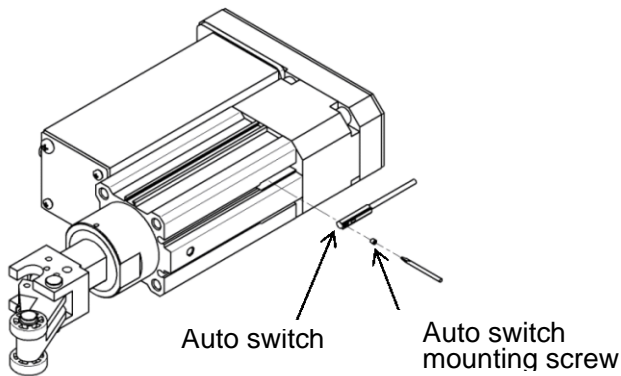

Tightening Torque for Auto Switch Mounting Screw (N·m)

Auto switch model	Tightening Torque
D-M9 D-M9□W D-M9□V D-M9□WV	0.05~0.15

Operating Range (mm)

Auto switch model	Model
	LEBQ40
D-M9 D-M9□W D-M9□V D-M9□WV	5.5

* Since the operating range is provided as a guideline Including hysteresis, it cannot be guaranteed. (assuming approximately ±30% dispersion) It may vary substantially depending on an ambient environment.

Precautions

Please perform actuator retraction when the conveyor is stopped.

- * This actuator is held on the lift end when de-energized. (Spring return)
- * This actuator is held on the retracted end with solenoid only when energized.
- * This actuator can be used in vertical directions only.
- * A short break function is included with this cylinder for protection.
- * Short break function: a function that slows the driving motor down if the rotation speed is over the designated value.
- * The motor will be turned OFF automatically by the internal circuit board after the actuator stops.
A dedicated controller or driver is not necessary.
- * The applicable auto switch is the D-M9* series.
- * Please check the RSQ series (size: 40) air stopper cylinder for the specifications that are not included in this document.
- * Regarding this product, if there is no individual contract or agreement regarding the Product Delivery Specifications, the safety instructions specified in the catalog are applied.
Please consult SMC Sales for details.



Caution To ensure the safest possible operation of this product, please be sure to thoroughly read the "Safety Instructions" in our "Best Pneumatics" catalog before use.