

! Contact our sales office for delivery dates and prices as this is a special model.

Specialized Product

Point to Group
P.G. information

Separate

Double check block with residual pressure release valve

VV71-FPGR-□-X299/X296



Double check block

VV72-FPG-06□-X2

Features

Drop prevention and temporary intermediate stops of cylinders are possible.

Variations

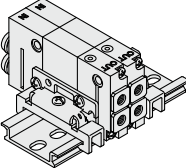
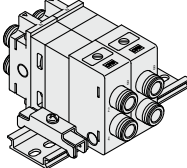
Applicable cylinder bore size [mm]	ø100 or less		ø140 or less	ø40 or less	ø63 or less
	Double check block with residual pressure release valve		Double check block	Double check block	
	VV71-FPGR-□-X299	VV71-FPGR-□-X296	VV72-FPG-06□-X2	VQ1000-FPG-□-□-□	VQ2000-FPG-□-□-□
				Refer to the Web Catalog .	
Model					
	Single unit	Manifold			
Residual pressure release valve	Yes	Yes	None	Yes	Yes

<Example of Operating Circuit>

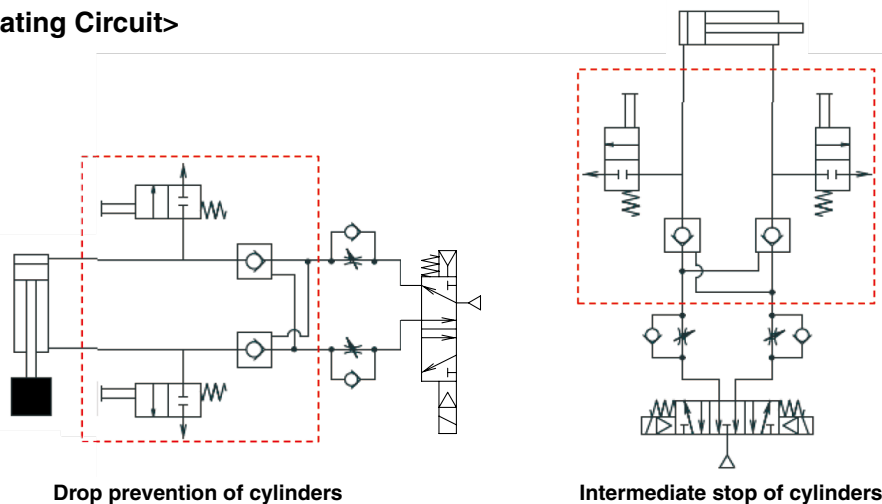

* Shows the circuits for the VV71-FPGR-□-X299 (With residual pressure release valve)



Caution

To ensure the safest possible operation of this product, please be sure to thoroughly read the "Safety Instructions" in our "Best Pneumatics" catalog before use.

Separate

Double check block with residual pressure release valve VV71-FPGR-□-X299/X296
 Double check block VV72-FPG-□-X2

Specialized Product **P.G.** Point to Group information

How to Order

Double check block with residual pressure release valve

Single unit

VV71 - FPGR - □ - X299

• Thread type

Nil	Rc
F	G
T	NPTF

Double check block with residual pressure release valve

Manifold

VV71 - FPGR - □ - X296

• Stations

Symbol	Stations	Hexagon socket head cap screw part no.
1	1 station	CA01445 (GT code)
2	2 stations	AXT632-45-22
3	3 stations	AXT632-45-15

Double check block*1

VV72 - FPG - 06 □ - X2

• Thread type

Nil	Rc
F	G
T	NPTF

*1 A separate 2-port valve is required for residual pressure release.

Specifications

Model	VV71-FRGR-□-X299	VV71-FRGR-□-X296	VV72-FPG-06□-X2
Fluid	Air		
Proof pressure	1.5 MPa		
Operating pressure range	0.1 to 1.0 MPa		
Ambient and fluid temperatures	5 to 60°C		
Sonic conductance [dm ³ /(s·bar)] [Effective area mm ²]	3.1 [15.5]		7.2 [36]
Port size	Rc3/8 NPTF3/8 G3/8		Rc3/4 NPTF3/4 G3/4
Applicable cylinder size (Reference)	Up to ø100		Up to ø140
Pressure difference between the inlet side and outlet side (At a supply pressure of 0.5 MPa)*1	0.03 MPa		0.02 MPa

*1 Due to its construction, a pressure difference is generated between the inlet side and outlet side.

Separate

Double check block with residual pressure release valve VV71-FPGR-□-X299/X296
Double check block VV72-FPG-□-X2

Specialized Product **P.G.** Point to Group information

Dimensions

VV71-FPGR-□-X299

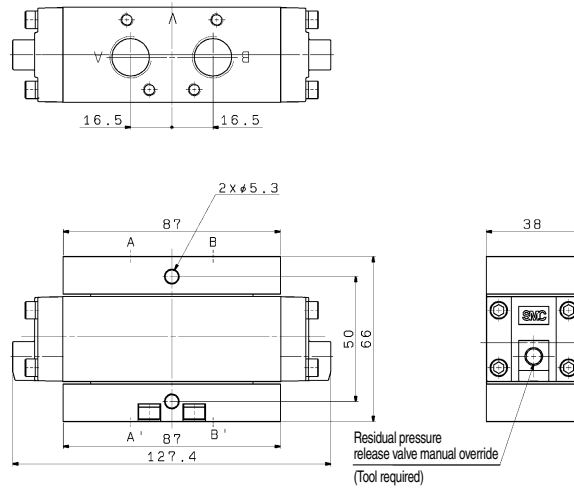

Symbol

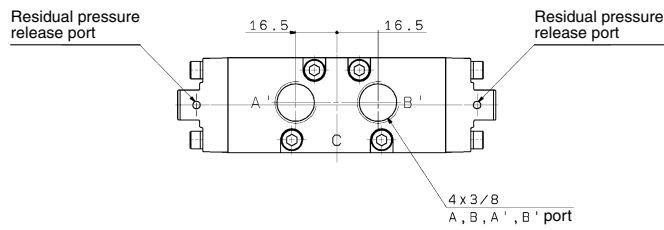
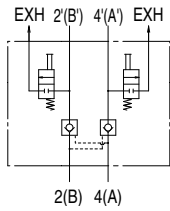

VV72-FPG-06□-X2

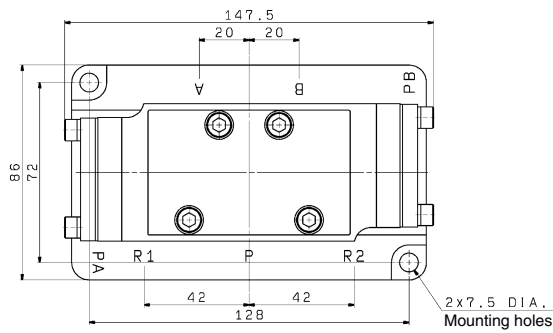

Symbol

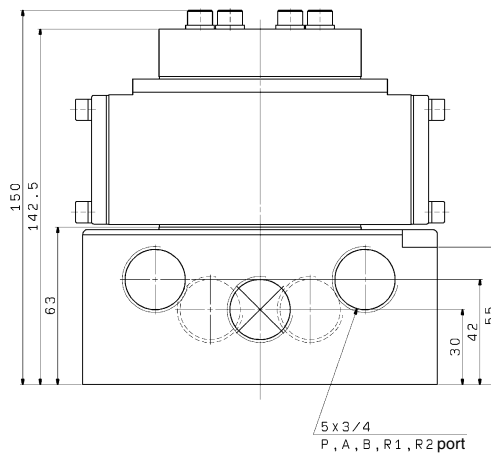
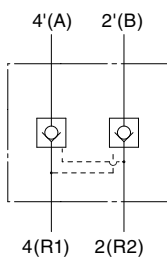

Separate

Double check block with residual pressure release valve VV71-FPGR-□-X299/X296
 Double check block VV72-FPG-□-X2

Specialized Product **P.G.** Point to Group information

Dimensions

VV71-FPGR-□-X296

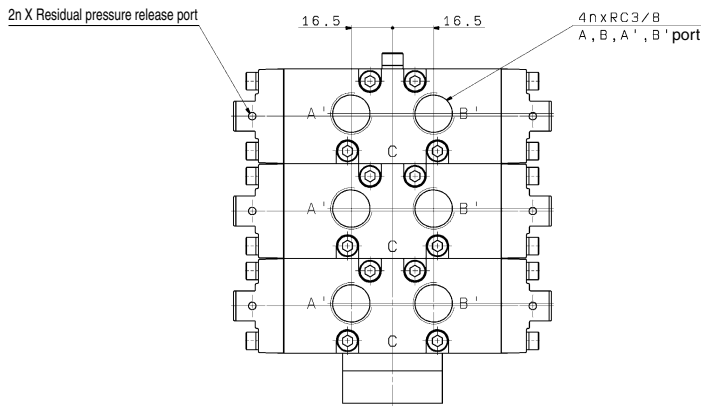
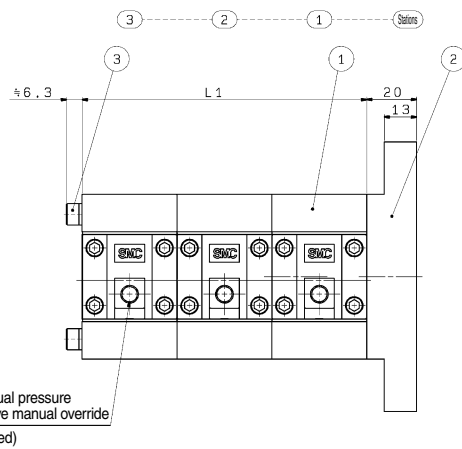
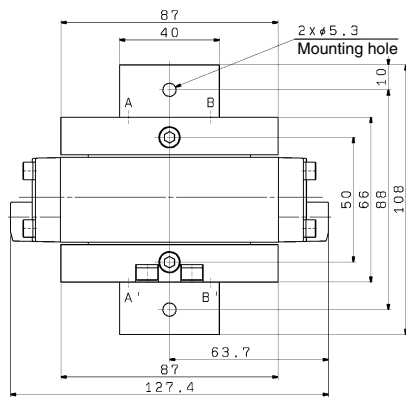
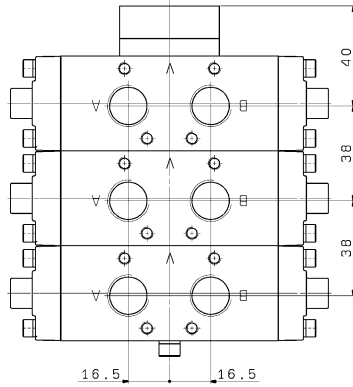

L1 Dimensions

Stations	L1 Dimensions
1	38
2	76
3	114

Symbol

