

! Contact our sales office for delivery dates and prices as this is a special model.

Specialized Product **P.G.** Point to Group information

Angle Seat Valve / Air Operated Type

JSB Series

Features

- Large flow rate
Cv factor: 28
- Compact
Height: 166 mm
- Long service life:
5 million cycles (Water/Air)
- Body material:
Stainless steel 316L equivalent
- Steam/Water/Air (All in one)
- Fluid temperature:
183°C or less (Steam)
99°C or less (Water/Air)

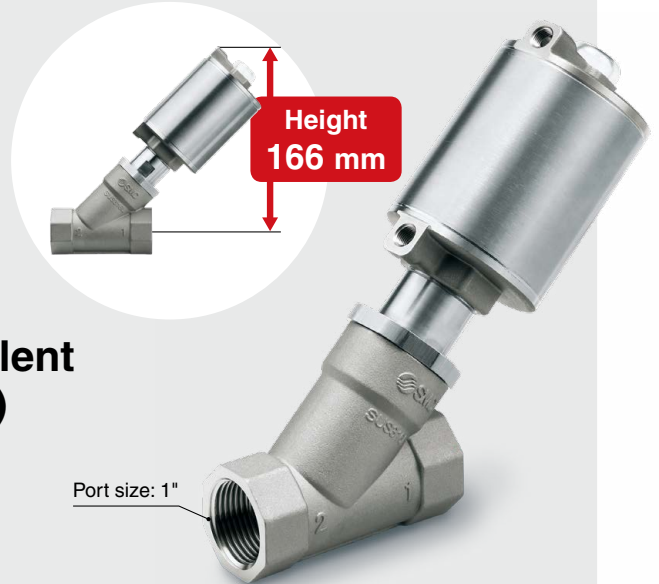

Clean design

Smooth head surface
(Material: Stainless steel 304)

Improved piping workability

The pilot port can be rotated 360°.

Long service life

SMC's unique shaft seal technology allows for a longer service life.

Indicator (Blue)

Standard feature

Large flow rate

A large flow rate is possible due to the optimized flow channel shape. (Cv factor: 28)
* Port size: 1"

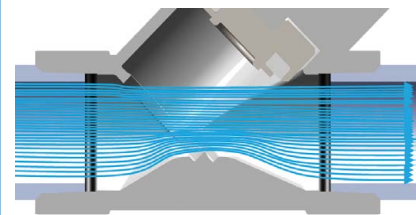

● Easy maintenance

Each part can be replaced.

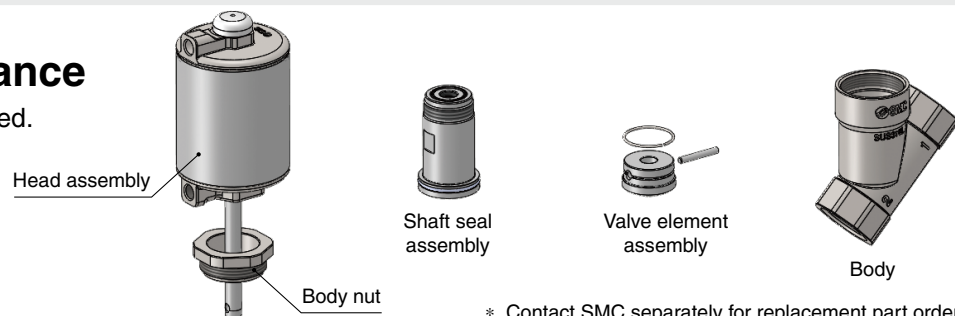

* Contact SMC separately for replacement part order numbers.



Caution

To ensure the safest possible operation of this product, please be sure to thoroughly read the "Safety Instructions" in our "Best Pneumatics" catalog before use.

SMC Corporation 4-14-1, SOTO-KANDA, CHIYODA-KU, TOKYO 101-0021, JAPAN URL: <https://www.smcworld.com>

©2022 SMC Corporation All Rights Reserved



SP218X-001E
P: AS