

Precision Clean Regulator

Series **SRP**

How to Order



JIS symbol

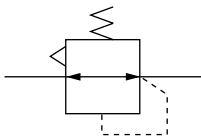

SRP 1 1 0 1 — 01 — R

Set pressure

0	0.005 to 0.2MPa
1	0.01 to 0.4MPa

Port size

Symbol	Piping port size
M5	M5 x 0.8
01	Rc 1/8

Gauge port orientation

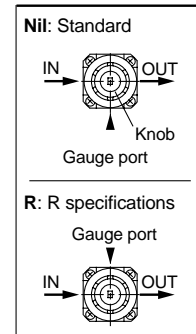

* Gauge port positions are indicated with the knob on the top side.

Options

Description	Model	Material
Bracket	B21-1-T1	Rolled steel plate (electroless nickel plated)

Specifications

Connection port size		M5, Rc 1/8
Fluid		Air, N ₂ , CO ₂ , Ar
Proof pressure MPa		1.5
Maximum operating pressure MPa		1.0
Regulating pressure range MPa	Low pressure type	0.005 to 0.2
	High pressure type	0.01 to 0.4
Ambient and fluid temperature (°C)		0 to 60
Fluid consumption /min (ANR) <small>Note 1)</small>		0.5 or less
Sensitivity		0.3% of full span
Repeatability		±1% of full span
Fluid-contact parts	Metal	SUS316
	Resin	Fluororesin
	Rubber	Fluoro rubber
	Other	Ceramics
Assembly environment		Clean room class 10000
Parts cleaning		HCFC141b ultrasonic cleaning of all fluid-contact parts

Note 1) At set pressure of 0.2MPa

Series SRP

Flow Characteristics

Fluid: Air

SRP1101-M5

Conditions/Upstream pressure: 0.5MPa

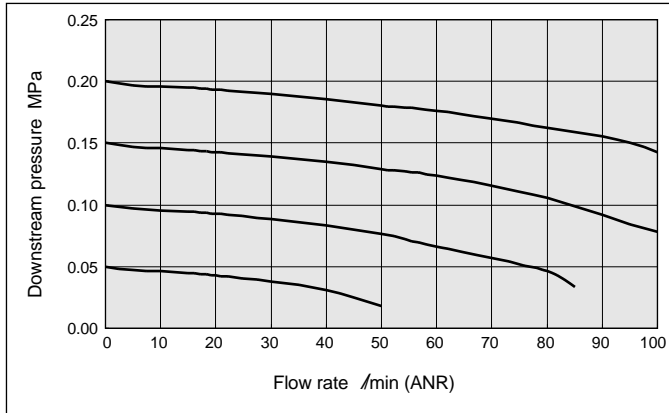

SRP1111-M5

Conditions/Upstream pressure: 0.7MPa

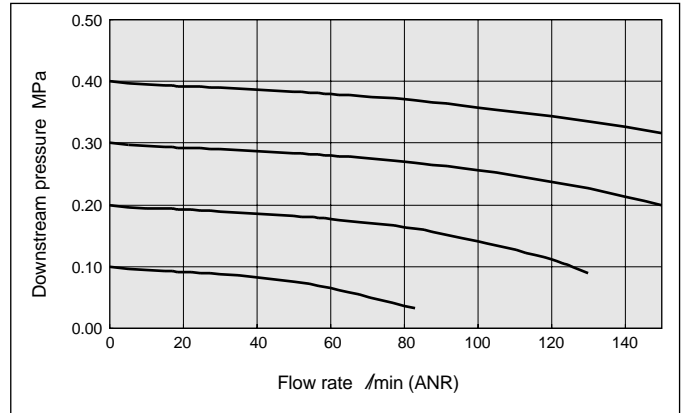

SRP1101-01

Conditions/Upstream pressure: 0.5MPa

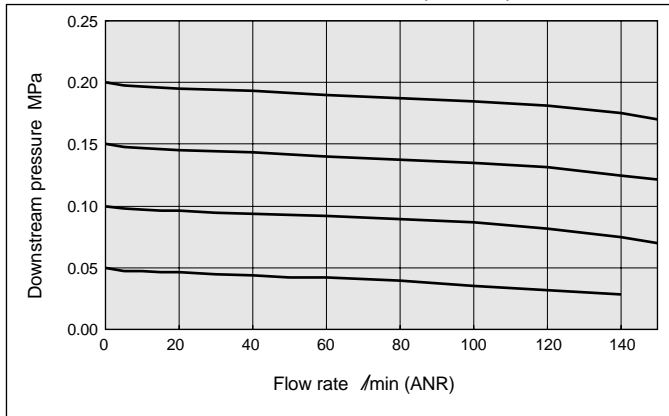

SRP1111-01

Conditions/Upstream pressure: 0.7MPa

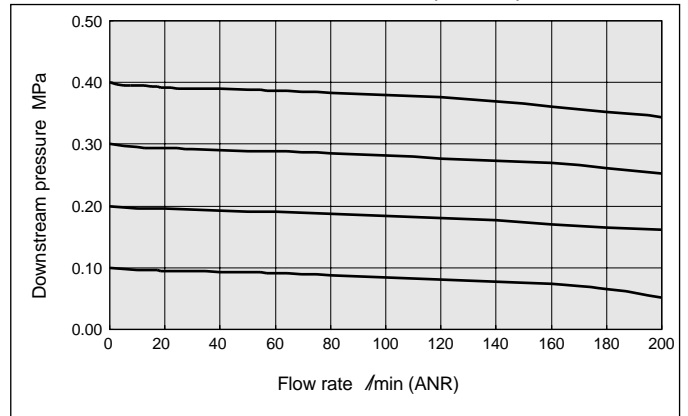

Pressure Characteristics

Fluid: Air

SRP1101

Initial setting/Upstream pressure: 0.7MPa
Downstream pressure: 0.1MPa

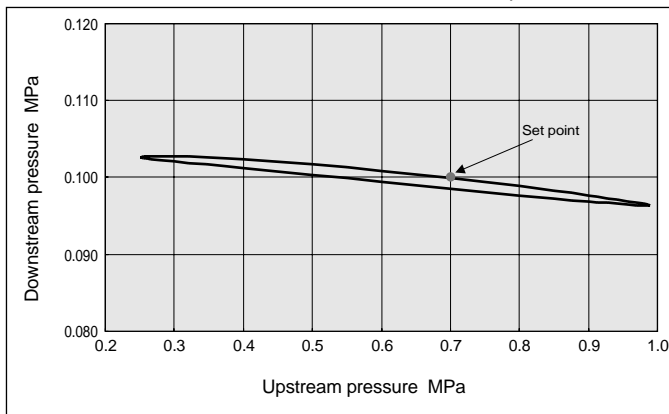

SRP1111

Initial setting/Upstream pressure: 0.7MPa
Downstream pressure: 0.2MPa

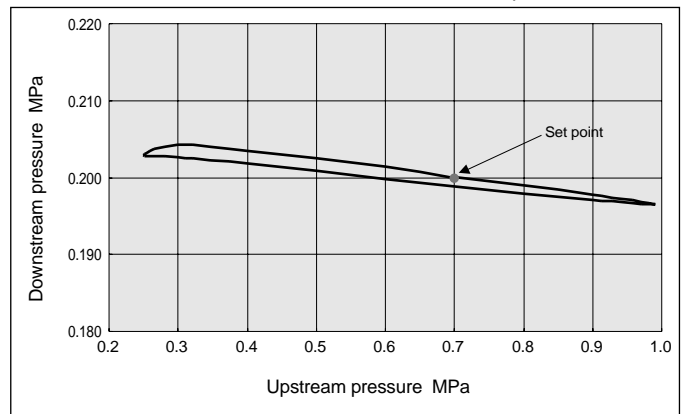

Construction

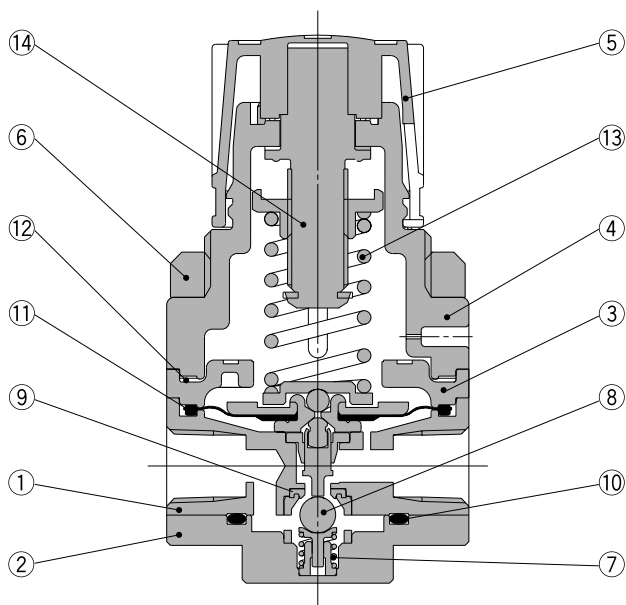

Parts list

No.	Description	Material	Treatment
1	Body	SUS316L	
2	Valve guide	SUS316	
3	Spacer	PPS	
4	Bonnet	PPS	
5	Knob	PBT	
6	Set nut	ZDC	Electroless nickel plated
7	Valve spring	SUS316	
8	Main valve	Ceramics	
9	Valve seat	PTFE	
10	O-ring	Fluoro rubber	
11	Diaphragm	Fluoro rubber	
12	Gasket	Fluoro rubber	
13	Pressure regulator spring	Steel wire	
14	Pressure regulator screw assembly	—	

Dimensions

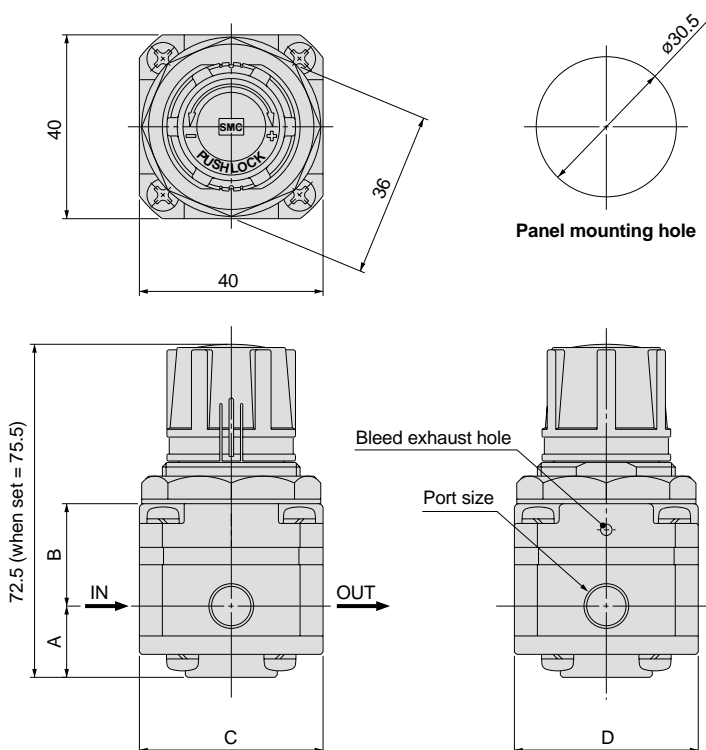

Bracket

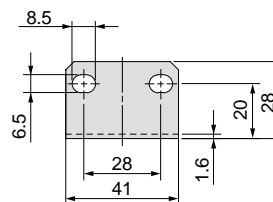
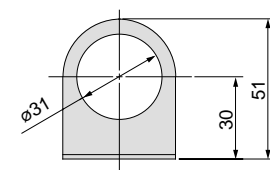

Model	Port size	A	B	C	D
SRP11□1-M5	M5 x 0.8	14	23.5	30	30
SRP11□1-01	Rc 1/8	15	22.5	40	40