

4 Port Solenoid Valve Common Specifications

Series SJ2000/3000



Manifold Specifications

Model	D-sub connector		Flat ribbon cable			Serial wiring		Individual wiring
	Type 60F	Type 60P	Type 60PG Type 60J Type 60G	Type 60PH	Type 60S□ (EX180)	Type 60S6B (EX510)	Type 60	
Manifold type	Plug-in, Connector type							Non-plug-in
1(P: SUP), 3/5(E: EXH)	Common SUP, EXH							
Valve stations	2 to 24 stations		2 to 18 stations (Type PG) 2 to 16 stations (Type J, Type G)	2 to 8 stations	2 to 32 stations	2 to 16 stations	2 to 20 stations	
Applicable connector	D-sub connector Conforming to MIL-C-24308 JIS-X-5101	Flat ribbon cable connector Socket: 26 pins MIL type with strain relief Conforming to MIL-C-83503	Flat ribbon cable connector Socket: 20 pins MIL type with strain relief Conforming to MIL-C-83503	Flat ribbon cable connector Socket: 10 pins MIL type with strain relief Conforming to MIL-C-83503	—	—	—	
Internal wiring	Non-polar, +COM							
4(A), 2(B) port piping spec.	Location	Valve						
	Direction	Horizontal, Upward, Downward (Using elbow fittings for upward or downward)						
Port size	1(P), 3/5(E) port		C6, C8, N7, N9 (Inch size elbow fitting is not available.)					
	4(A), 2(B) port	SJ2000	C2, C4, N1, N3, M3					
		SJ3000	C2, C4, C6, N1, N3, N7, M5					
Weight W (g) ^{Note 2)}	n: Number of SUP/EXH blocks m: Weight of DIN rail		$W = 51n + m + 133$					

Note 1) When many valves are operated simultaneously, use B type (SUP/EXH both sides), applying pressure to the 1(P) ports on both sides and exhaust from the 3/5(E) ports on both sides.

Note 2) The weight W is the value for the D-sub connector manifold only with internal pilot, SUP/EXH block straight fittings specifications. To obtain the weight with solenoid valves attached, add the solenoid valve weights given on page 3 for the appropriate number of stations. Refer to page 61 for the weight of DIN rail. (Please contact SMC for the weight of external pilot specifications, elbow fittings.)

Flow Characteristics

SJ2000

Port size		Flow characteristics					
1(P) 3/5(E)	4, 2 (A, B)	1→2/4 (P→A/B)			4/2→3/5 (A/B→E)		
		C [dm ³ /(s·bar)]	b	Cv	C [dm ³ /(s·bar)]	b	Cv
C8	C2	0.13	0.55	0.04	0.13	0.50	0.04
	C4	0.33	0.16	0.08	0.36	0.13	0.08
	M3	0.18	0.52	0.06	0.20	0.29	0.06

SJ3000

Port size		Flow characteristics					
1(P) 3/5(E)	4, 2 (A, B)	1→2/4 (P→A/B)			4/2→3/5 (A/B→E)		
		C [dm ³ /(s·bar)]	b	Cv	C [dm ³ /(s·bar)]	b	Cv
C8	C2	0.13	0.56	0.04	0.14	0.51	0.04
	C4	0.42	0.17	0.11	0.45	0.16	0.11
	C6	0.55	0.10	0.12	0.56	0.11	0.12
	M5	0.40	0.28	0.11	0.45	0.15	0.11

Note) The value is for manifold base with 5 stations and individually operated 2 position type.
Please contact SMC for 4 position dual 3 port valves.

Plug-in Connector Type Manifold

Series SJ2000/3000

P.10 D-sub Connector / Flat Ribbon Cable / PC Wiring



P.26 PC Wiring System with Power Supply Terminal

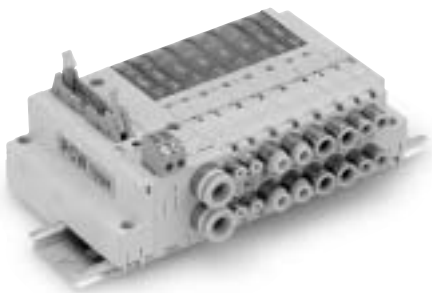

P.34 Serial Wiring: EX180



P.42 Gateway System Serial Transmission System: EX510

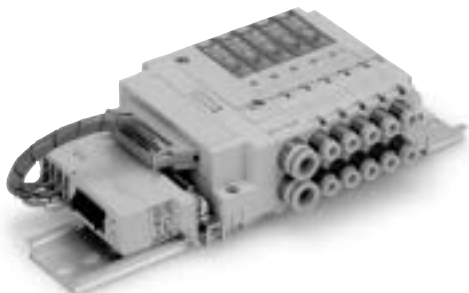

Plug-in Connector Type PC Wiring System with Power Supply Terminal Series **SJ2000/3000**

How to Order

● Connector type manifold

SS5J **3** - **60GD** - **05U** **□** **□** **□**

Series

2	SJ2000
3	SJ3000 (SJ2000/3000 mixed)

Mixed mounting type

Nil	Standard <small>(Note 1)</small>
M	Mixed mounting <small>(Note 2)</small>

Note 1) There is no need to enter anything when you operate either the SJ2000 or SJ3000 series alone.

Note 2) Enter "M" when the SJ2000 or SJ3000 series will be mounted on the same manifold base together.

Connector type

Flat ribbon cable
(20 pins)

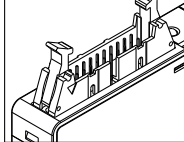

Connector mounting position

Symbol	Mounting position
D	D side

● DIN rail length specified

Nil	Standard length	
3	3 stations	Specify a longer rail than the standard length.
⋮	⋮	
16	16 stations	

* Specify the valve stations not exceeding the maximum stations.

● SUP/EXH block fitting spec.

Nil	Straight fitting With external pilot spec. X, PE port	
L	Elbow fitting (Upward) With external pilot spec. X, PE port	
B	Elbow fitting (Downward) With external pilot spec. X, PE port	

* There is no need to enter anything when the SUP/EXH block mounting position "M" is selected.

● Pilot spec.

Nil	Internal pilot
S	Internal pilot / Built-in silencer
R	External pilot
RS	External pilot / Built-in silencer

* There is no need to enter anything when the SUP/EXH block mounting position "M" is selected.

* For built-in silencers, the 3/5(E) ports are plugged.

● SUP/EXH block mounting position

U	U side (2 to 10 stations)
D	D side (2 to 10 stations)
B	Both sides (2 to 16 stations)
M*	Special specifications

* Specify the required specifications (including port sizes other than ø8) by means of the manifold specification sheet.

● Valve stations

Symbol	Stations	Note
02	2 stations	Up to 16 solenoids possible.
⋮	⋮	
16	16 stations	

* The number of the blanking block assembly is also included. Since single and double wiring are available with the blanking block assembly, select a model compatible with the valve wiring spec. planned for the future. (Refer to page 61.)

How to Order Valve Manifold Assembly

Ordering example (SJ3000)

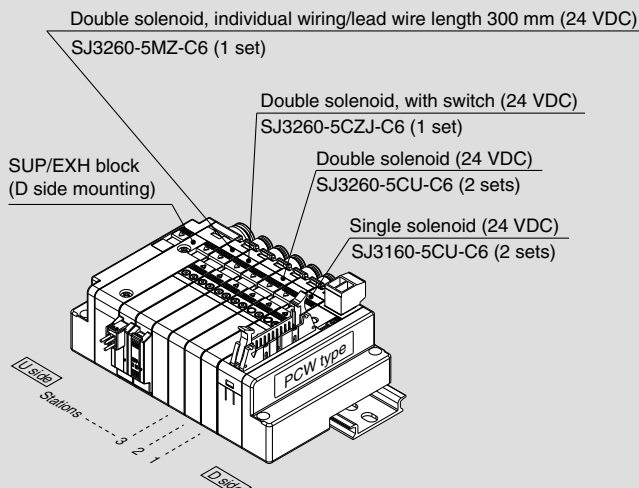

SS5J3-60GD-06U 1 set (Manifold part no.)
 * **SJ3160-5CU-C6** 2 sets (Single solenoid part no.)
 * **SJ3260-5CU-C6** 2 sets (Double solenoid part no.)
 * **SJ3260-5CZJ-C6** 1 set (Double solenoid, with switch part no.)
 * **SJ3260-5MZ-C6** 1 set (Double solenoid, individual wiring/lead wire length 300 mm part no.)

→ The asterisk denotes the symbol for assembly.
 Prefix to the part no. of the solenoid valve, etc.

- The valve arrangement is numbered as the 1st station from D side.
- Indicate the valves to be attached below the manifold part number, in order starting from station 1 as shown in the drawing. In the case of complex arrangement, specify them in the manifold specification sheet.



For the wiring to power supply terminal, refer to back page 9.

Series SJ2000/3000

Manifold Electrical Wiring

Type 60G: Flat ribbon cable (20 pins, PC wiring with power supply terminal)

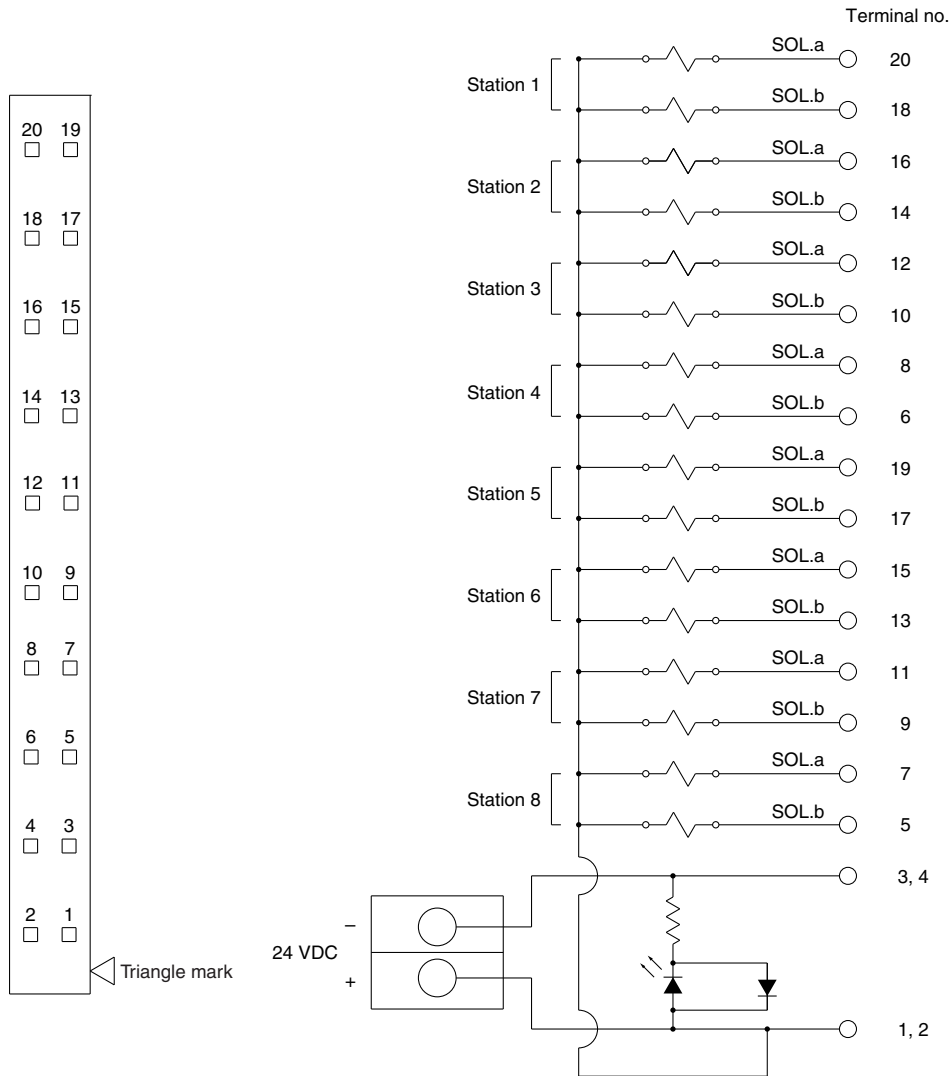

Note 1) This circuits are for the specifications with up to 8 stations of 2 position double, 3 position and 4 position dual 3 port valves. These should be wired in order 20→18→16→14 without skipping or leaving any connectors remaining.
 Note 2) For details on PC wiring systems, refer to "PC Wiring System" catalog (CAT.ES02-20B).

Dimensions

SS5J3-60GD- Stations U (S, R, RS)

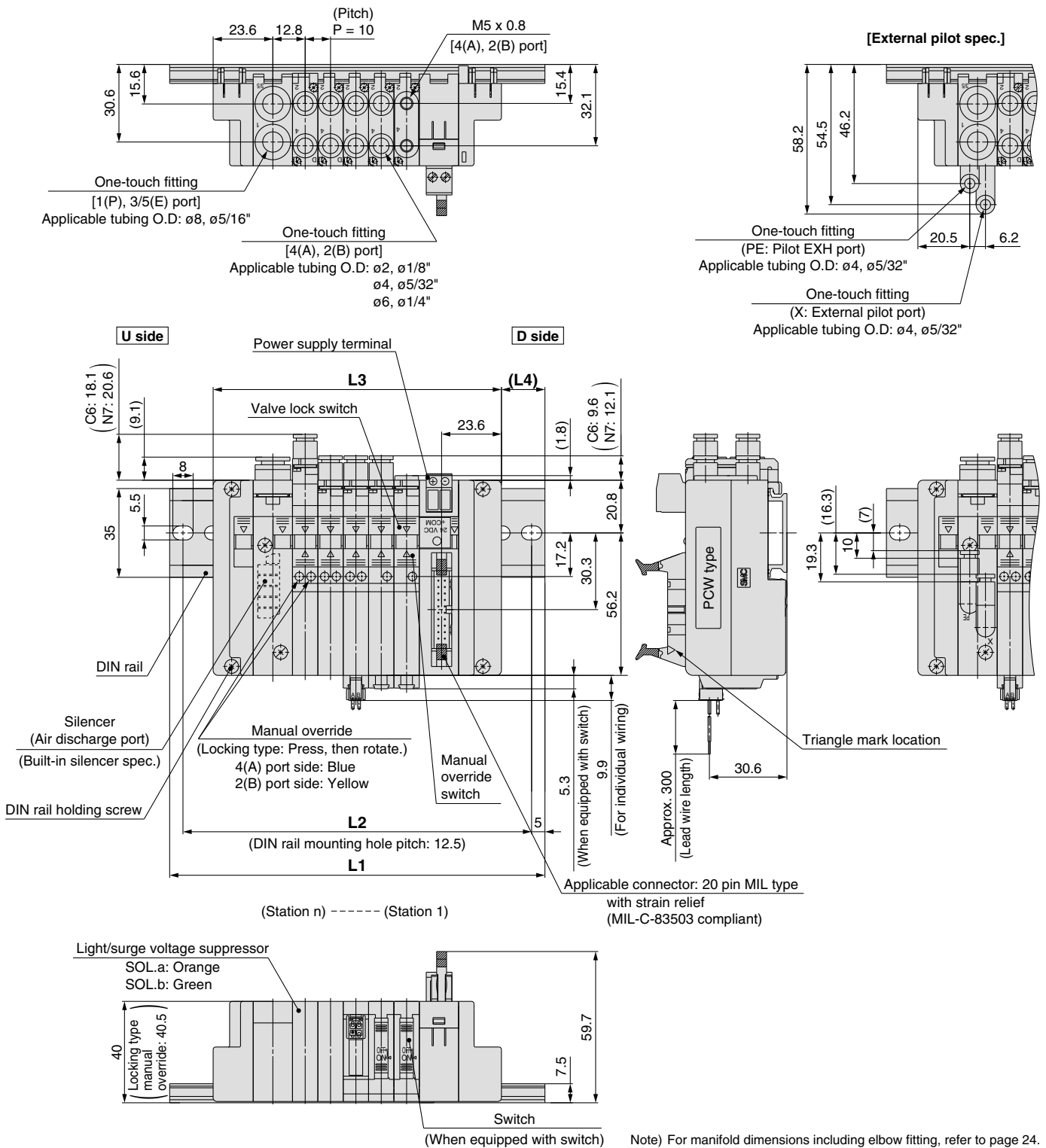

Note) For manifold dimensions including elbow fitting, refer to page 24.

L: Dimensions

n: Stations

L \ n	2	3	4	5	6	7	8	9	10
L1	110.5	123	135.5	148	148	160.5	173	185.5	198
L2	100	112.5	125	137.5	137.5	150	162.5	175	187.5
L3	83.7	93.7	103.7	113.7	123.7	133.7	143.7	153.7	163.7
L4	13	14.5	15.5	16.5	11.5	12.5	14	15	16

Series SJ2000/3000

Dimensions

SS5J3-60GD- Stations B (S, R, RS)

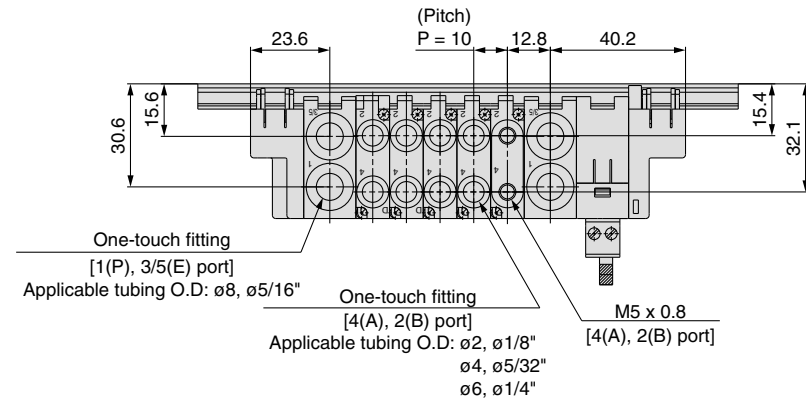

[External pilot spec.]
(There is a piping of X, PE port in the both sides.)

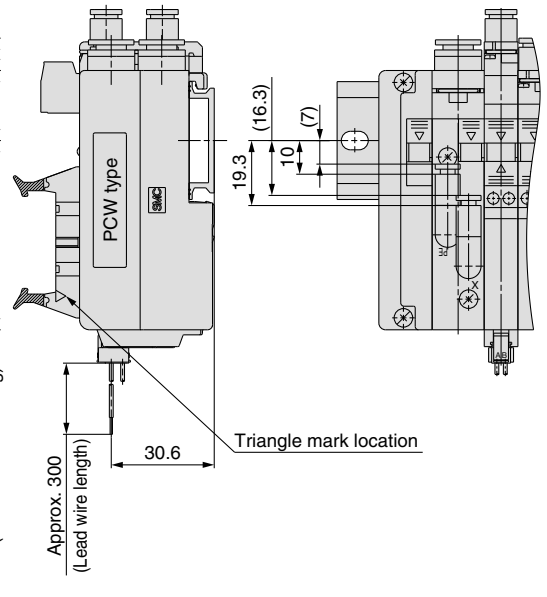
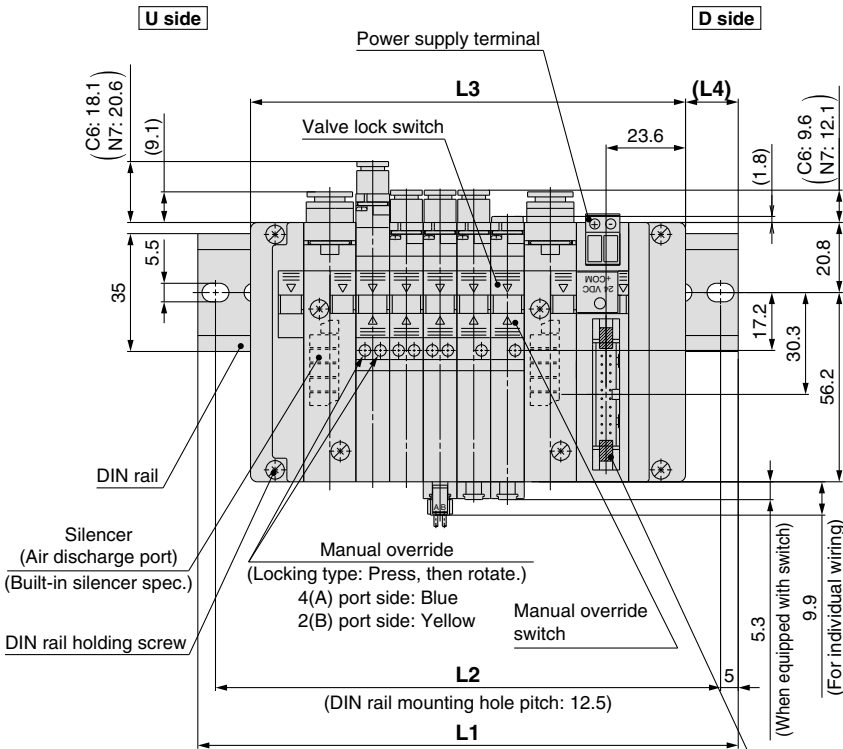
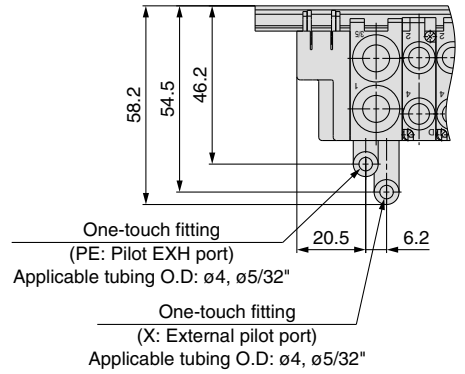

Applicable connector: 20 pin MIL type
with strain relief
(MIL-C-83503 compliant)

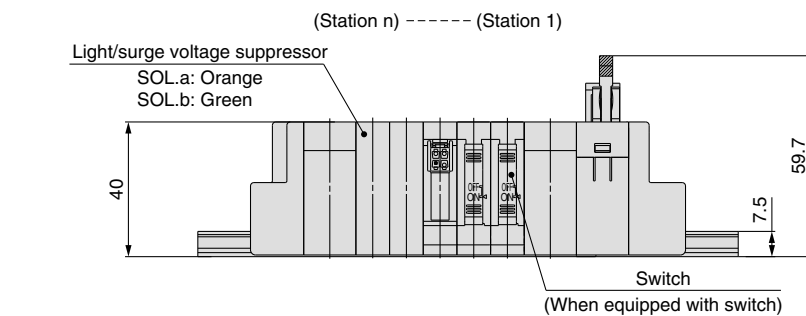

Note) For manifold dimensions including elbow fitting, refer to page 24.

L: Dimensions

L \ n	2	3	4	5	6	7	8	9	10	11	12	13	14	15	16
L1	123	135.5	148	160.5	173	185.5	185.5	198	210.5	223	235.5	235.5	248	260.5	273
L2	112.5	125	137.5	150	162.5	175	175	187.5	200	212.5	225	225	237.5	250	262.5
L3	99.2	109.2	119.2	129.2	139.2	149.2	159.2	169.2	179.2	189.2	199.2	209.2	219.2	229.2	239.2
L4	11.5	13	14	15	16.5	17.5	12.5	13.5	14.5	16	17	12	13	14	15.5

n: Stations

Manifold Exploded View

Type 60P (Flat ribbon cable) manifold

Type 60S (Plug-in, EX180 Serial wiring) manifold

Type 60G (Plug-in, PC wiring with power supply terminal) manifold

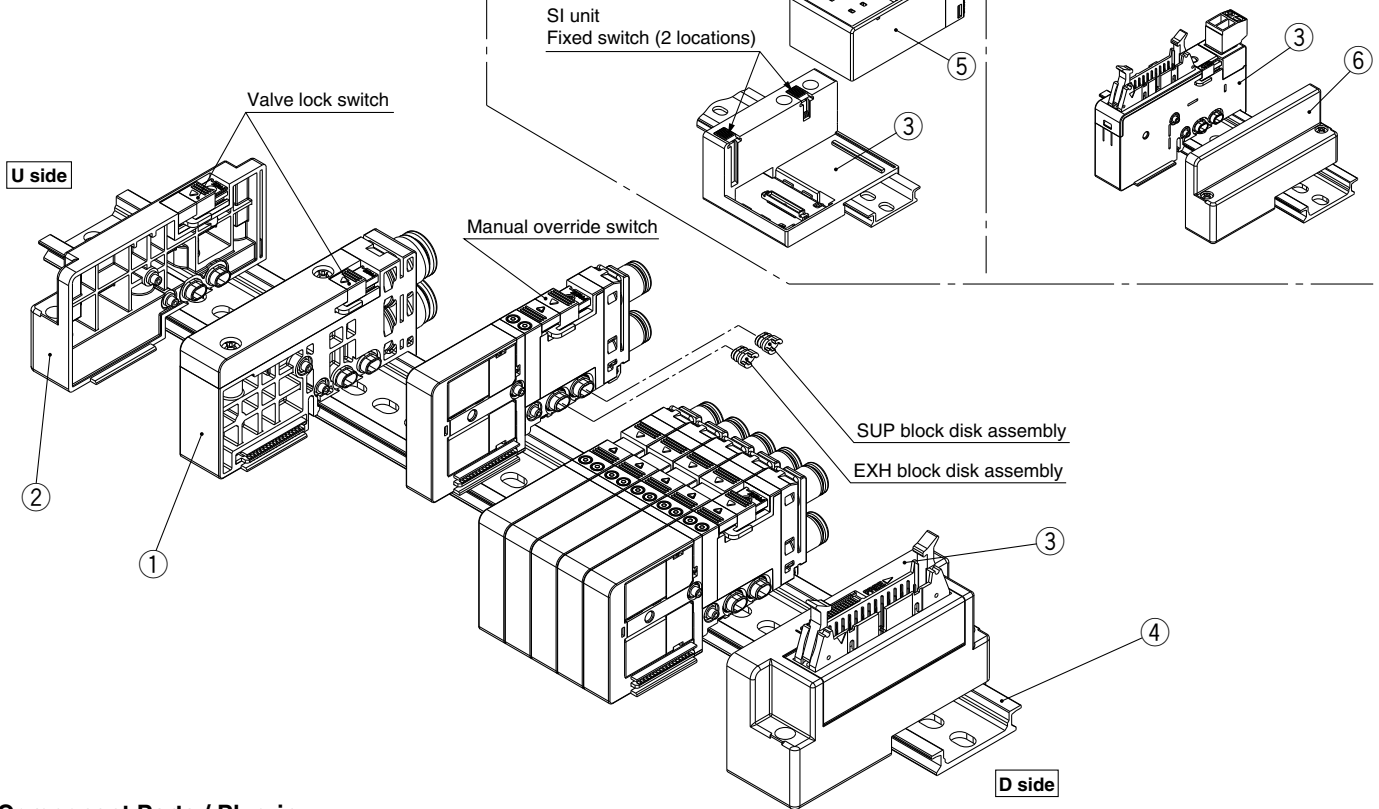

Component Parts / Plug-in

No.	Description	Part no.	Note
1	Internal pilot	SJ3000-50-1A-□□	(Metric size) C6: With ø6 one-touch fitting (straight) C8: With ø8 one-touch fitting (straight) L6: With ø6 one-touch fitting (elbow upward entry) L8: With ø8 one-touch fitting (elbow upward entry) B6: With ø6 one-touch fitting (elbow downward entry) B8: With ø8 one-touch fitting (elbow downward entry)
	Internal pilot / Built-in silencer	SJ3000-50-1AS-□□	
	External pilot	SJ3000-50-1AR-□□ (X, PE port: Metric size ø4 Inch size ø5/32")	
	External pilot / Built-in silencer	SJ3000-50-1ARS-□□ (X port: Metric size ø4 Inch size ø5/32")	
	For different pressures, internal pilot ^{Note 1)}	SJ3000-50-3A-□□	
	For different pressures ^{Note 1)} Internal pilot / Built-in silencer	SJ3000-50-3AS-□□	
2	End block assembly	SJ3000-53-1A	For U side
3	Connector block assembly	SJ3000-42-□A-□ SJ3000-76-2A-□	Refer to the connector block assembly part no. shown below.
4	DIN rail	VZ1000-11-1-□	Refer to page 61.
5	SI unit	EX180-□□	Refer to the SI unit part numbers on page 34.
6	End block assembly	SJ3000-53-2A	For D side

Note 1) The valves cannot be operated only with the SUP/EXH block assembly for different pressure, select them in combination with the SUP/EXH block assembly for internal/external pilot.

Note 2) Refer to page 60 about the SUP/EXH block disk assembly and method of handling of parts at different pressures.

Connector Block Assembly Part No.

Connector specifications	Mounting position	Part no.	Note
For D-sub connector	D side	SJ3000-42-1A-□	□: 1 (Connector upward) □: 2 (Connector lateral)
For flat ribbon cable 26 pins		SJ3000-42-2A-□	
For flat ribbon cable 20 pins		SJ3000-42-3A-□	
For flat ribbon cable 10 pins		SJ3000-42-4A-□	
For PC wiring 20 pins		SJ3000-42-6A-□	
For EX180 serial wiring ^{Note)}		SJ3000-42-5A	
For PC wiring 20 pins with power supply terminal		SJ3000-76-2A-05	

Note) SI unit is not included.

Series SJ2000/3000

How to Add Manifold Stations

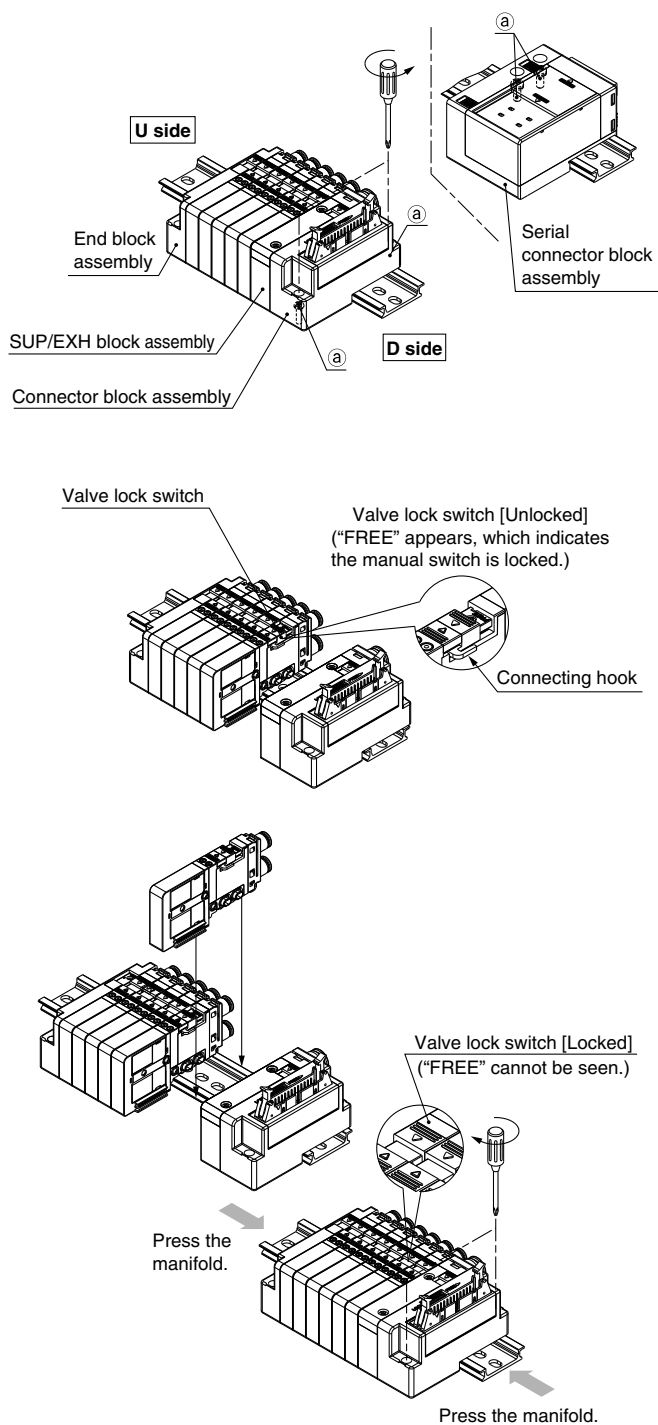

Caution (D-sub, Connector block assembly for flat ribbon cable, End block assembly M3: 0.6 N·m
Connector block assembly for EX180 serial wiring M4: 1.4 N·m
Mounting bracket for EX510 serial wiring M4: 0.6 N·m)

Caution

- When increasing the number of stations from 10 or below to 11 or above, increase the number of SUP/EXH assemblies as well.
- Be sure to turn off the power and stop the supply of air before disassembly. Furthermore, since air may remain inside the actuator, piping and manifold, confirm that the air is completely exhausted before performing any work.
- After assembly and disassembly, air leakage could occur if blocks are not well connected or a thread is not tightly fastened onto the end block assembly. Before supplying air, make sure that no gaps exist in between blocks and that the valve and block are tightly fastened onto the DIN rail. Also, make sure that air is not leaking before use.
- For the SJ3A6 series manifold with vacuum release valve with restrictor, there is no valve lock switch for connecting, so when mounting, tighten the screws after checking that there are no gaps between valves.