

Series SQ2000 Plug-in Manifold

How to Order Manifold

SS5Q23 — 08 — FD2 — D — □

Stations

01	1 station
⋮	⋮
16 ^{Note)}	16 stations

Note) The maximum number of stations depends on the type of electrical entries.

Manifold mounting

D	DIN rail mounting style
E	Direct mounting style

Option

Nil	None
02 to 24 ⁽¹⁾	DIN rail length specified
B	Back pressure check valve
K ⁽²⁾	Special wiring specifications (Except double wiring)
N	With name plate (Side ported only)
R	External pilot specifications
S	Built-in silencer, direct exhaust

Note 1) Specify DIN rail length with "D□" at the end. (Enter the number of stations inside □.) Example: -D08
 Note 2) Standard wiring specifications are for double wiring. Indicate wiring specifications for single wiring or mixed single and double wiring, or when exceeding the standard maximum number of stations. (Except L kit.)
 Note 3) For specifying two or more options, enter them alphabetically. Example: -BKN

Electrical entry

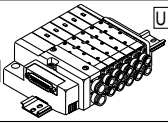
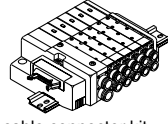
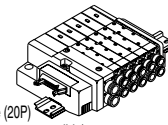
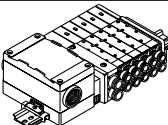
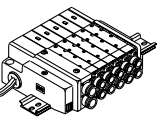
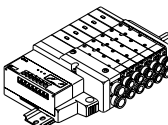
Kit type	Lead wire connector location	Cable specifications	Stations	Max. number of stations for special wiring specifications	Max. number of solenoids ⁽²⁾
F kit  D-sub Connector kit	FD0	D-sub connector (25P) kit, without cable	1 to 12 stations	16 stations	24
	FD1	D-sub connector (25P) kit, with 1.5 m cable			
	FD2	D-sub connector (25P) kit, with 3.0 m cable			
	FD3	D-sub connector (25P) kit, with 5.0 m cable			
P kit  Flat ribbon cable connector kit (26P/20P)	PD0	Flat ribbon cable (26P) kit, without cable	1 to 12 stations	16 stations	24
	PD1	Flat ribbon cable (26P) kit, with 1.5 m cable			
	PD2	Flat ribbon cable (26P) kit, with 3.0 m cable			
	PD3	Flat ribbon cable (26P) kit, with 5.0 m cable			
	PDC	Flat ribbon cable (20P) kit, without cable	1 to 9 stations	18	
J kit  Flat ribbon cable (20P) (PC Wiring System compatible)	JD0	Flat ribbon cable (20P) PC Wiring System compatible	1 to 8 stations	16 stations	16
T kit  Terminal block box kit	TD0	Terminal block box kit	1 to 10 stations	16 stations	16
L kit  Lead wire kit	LD0	Lead wire kit with 0.6 m cable	1 to 12 stations	—	—
	LU0				
	LD1	D side			
	LU1	U side			
	LD2	D side			
S kit  Serial transmission kit	SDF	NKE Corp.: Uni-wire System	1 to 8 stations	16 stations	16
	SDH	NKE Corp.: Uni-wire H System			
	SDJ1	SUNX Corp.: S-LINK System (16 output points)			
	SDJ2	SUNX Corp.: S-LINK System (8 output points)	1 to 4 stations	8 stations	8
	SDQ	DeviceNet, CompoBus/D (OMRON Corp.)	1 to 8 stations	16 stations	16
	SDR1	OMRON Corp.: CompoBus/S System (16 output points)			
	SDR2	OMRON Corp.: CompoBus/S System (8 output points)			
	SDV	Mitsubishi Electric Corp.: CC-LINK System	1 to 8 stations	16 stations	16

Note 1) Separately order the 20P type cable assembly for the P kit.
 Note 2) The maximum number of stations should not be more than the maximum number of solenoids. (The number of solenoids are counted as: 1 for single solenoids and 2 for type 3P and 4P double solenoids.)

Series SQ2000

Manifold Option

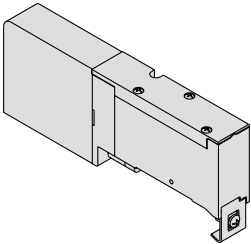
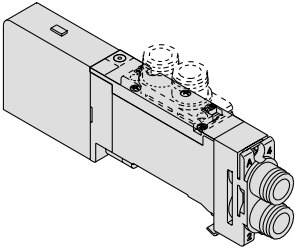
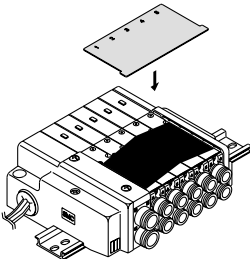
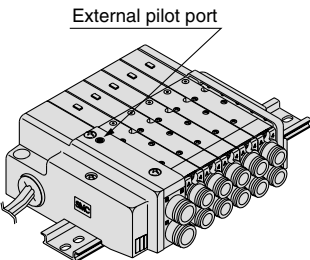
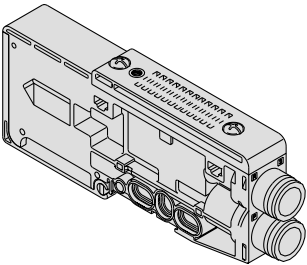
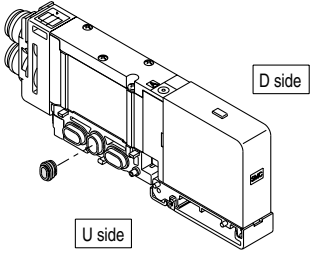
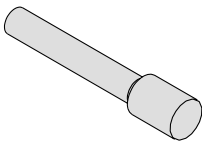
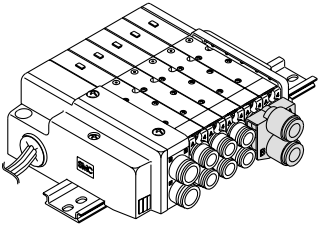
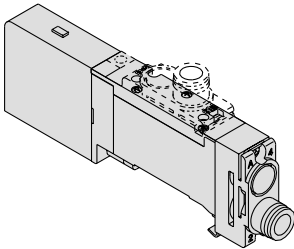
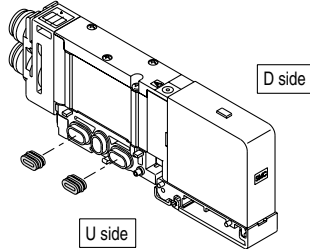
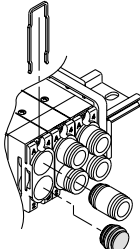
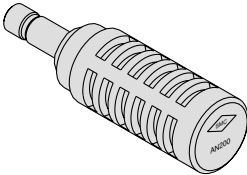
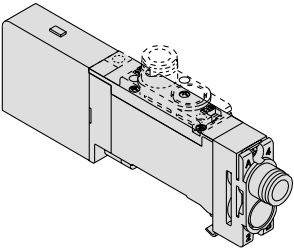
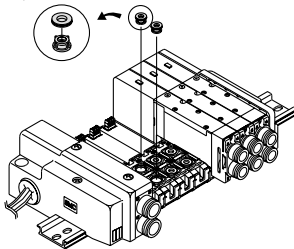
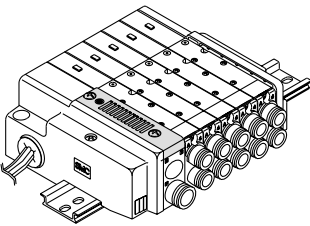
<p>Blanking plate P. 2-3-49 SSQ2000-10A-3</p> 	<p>Individual SUP/EXH spacer P. 2-3-50 SSQ2000-PR1-3-C8 L8</p> 	<p>Name plate (-N) P. 2-3-52 SSQ2000-N3-n</p> 	<p>External pilot specifications (-R) P. 2-3-53</p> <p>External pilot port</p> 																												
<p>SUP/EXH block P. 2-3-49 SSQ2000-PR-3-C10 (-S)</p> 	<p>SUP block plate P. 2-3-51 SSQ1000-B-R</p> <p>D side</p> <p>U side</p> 	<p>Blanking plug P. 2-3-52 KQ2P-04/06/08/10</p> 	<p>Dual flow fitting P. 2-3-53 SSQ2000-52A-C10 N11</p> 																												
<p>Individual SUP spacer P. 2-3-49 SSQ2000-P-3-C8 L8</p> 	<p>EXH block plate P. 2-3-51 SSQ2000-B-R</p> <p>D side</p> <p>U side</p> 	<p>Port plug P. 2-3-52 VVQZ2000-CP</p> 	<p>Silencer (For EXH port) P. 2-3-53</p> 																												
<p>Individual EXH spacer P. 2-3-50 SSQ2000-R-3-C8 L8</p> 	<p>Back pressure check valve (-B) P. 2-3-51 SSQ2000-BP</p> 	<p>Built-in silencer (-S) P. 2-3-52</p> 	<p>Special wiring specifications (-K) P. 2-3-54</p> <p>D-sub connector</p> <table border="1"> <thead> <tr> <th>Connector terminal no.</th> <th>Terminal no.</th> </tr> </thead> <tbody> <tr> <td>14 ○ 01</td> <td>SOLA ○ 1 (-)</td> </tr> <tr> <td>15 ○ 02</td> <td>SOLA ○ 14 (-)</td> </tr> <tr> <td>16 ○ 03</td> <td>SOLA ○ 2 (-)</td> </tr> <tr> <td>17 ○ 04</td> <td>SOLA ○ 15 (-)</td> </tr> <tr> <td>18 ○ 05</td> <td>SOLA ○ 3 (-)</td> </tr> <tr> <td>19 ○ 06</td> <td>SOLB ○ 16 (-)</td> </tr> <tr> <td>20 ○ 07</td> <td>SOLA ○ 4 (-)</td> </tr> <tr> <td>21 ○ 08</td> <td>SOLA ○ 5 (-)</td> </tr> <tr> <td>22 ○ 09</td> <td>SOLA ○ 8 (-)</td> </tr> <tr> <td>23 ○ 10</td> <td>SOLA ○ 18 (-)</td> </tr> <tr> <td>24 ○ 11</td> <td>SOLA ○ 6 (-)</td> </tr> <tr> <td>25 ○ 12</td> <td>SOLB ○ 19 (-)</td> </tr> <tr> <td>○ 13</td> <td>COM. ○ 13 (+)</td> </tr> </tbody> </table> <p>Although the standard products come with double wiring, mixed single and double wiring is available upon request.</p>	Connector terminal no.	Terminal no.	14 ○ 01	SOLA ○ 1 (-)	15 ○ 02	SOLA ○ 14 (-)	16 ○ 03	SOLA ○ 2 (-)	17 ○ 04	SOLA ○ 15 (-)	18 ○ 05	SOLA ○ 3 (-)	19 ○ 06	SOLB ○ 16 (-)	20 ○ 07	SOLA ○ 4 (-)	21 ○ 08	SOLA ○ 5 (-)	22 ○ 09	SOLA ○ 8 (-)	23 ○ 10	SOLA ○ 18 (-)	24 ○ 11	SOLA ○ 6 (-)	25 ○ 12	SOLB ○ 19 (-)	○ 13	COM. ○ 13 (+)
Connector terminal no.	Terminal no.																														
14 ○ 01	SOLA ○ 1 (-)																														
15 ○ 02	SOLA ○ 14 (-)																														
16 ○ 03	SOLA ○ 2 (-)																														
17 ○ 04	SOLA ○ 15 (-)																														
18 ○ 05	SOLA ○ 3 (-)																														
19 ○ 06	SOLB ○ 16 (-)																														
20 ○ 07	SOLA ○ 4 (-)																														
21 ○ 08	SOLA ○ 5 (-)																														
22 ○ 09	SOLA ○ 8 (-)																														
23 ○ 10	SOLA ○ 18 (-)																														
24 ○ 11	SOLA ○ 6 (-)																														
25 ○ 12	SOLB ○ 19 (-)																														
○ 13	COM. ○ 13 (+)																														

How to Order Manifold Assembly (Example)

Example: D-sub connector kit, with cable (3 m)

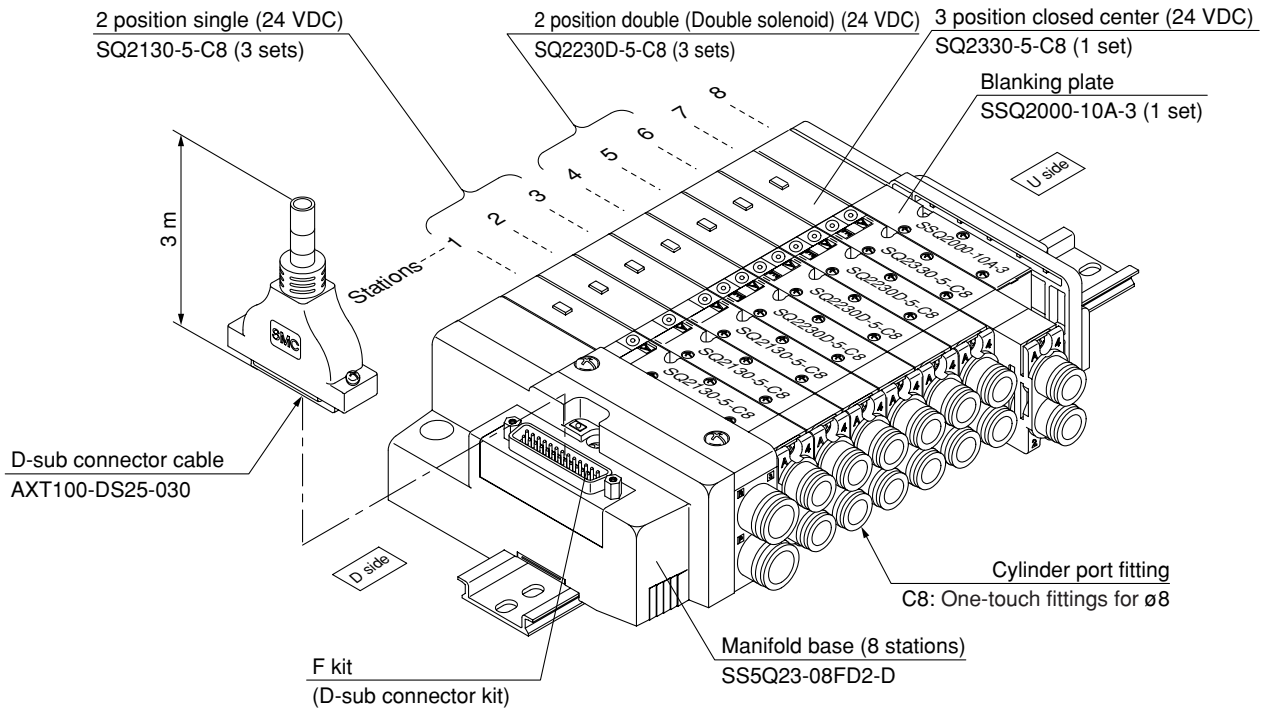

VQC
SQ
VQ0
VQ4
VQ5
VQZ
VQD

SS5Q23-08FD2-D	1 set (F kit 8 station manifold base)
* SQ2130-5-C8	3 sets (2 position single)
* SQ2230D-5-C8	3 sets (2 position double [Double solenoid])
* SQ2330-5-C8	1 set (3 position closed center)
* SSQ2000-10A-3	1 set (Blanking plate)

→ The asterisk denotes the symbol for assembly. Prefix it to the part nos. of the solenoid valve, etc.

Add the valve and option part numbers in order starting from the first station on the D side.
When entry of part numbers becomes complicated, indicate on the manifold specification sheet.

Manifold Specifications

Base model	Porting specifications		Applicable solenoid valve	Type of connection	Applicable ⁽³⁾ stations	5 station weight ⁽⁴⁾ (g)	1 station weight ⁽⁴⁾ (g)	
	Port size ⁽¹⁾							
	1(P), 3(R)	4(A), 2(B)						
		Port location	Port size					
Series SQ2000	C10 (For ø10)	Side	C4 (For ø4) C6 (For ø6) C8 (For ø8)	F kit: D-sub connector P kit: Flat ribbon cable J kit: Flat ribbon cable PC Wiring System compatible T kit: Terminal block L kit: Lead wire S kit: Serial transmission	1 to 12 stations	580	35	
SS5Q23-□□□□			Option Built-in silencer, direct exhaust		Top ⁽²⁾	L4 (For ø4) L6 (For ø6) L8 (For ø8)	26P	1 to 12 stations
	20P	1 to 9 stations						
	1 to 8 stations	580					35	
	1 to 10 stations	1,165					620	
	1 to 12 stations	620					50	
1 to 8 stations	650	35						



Note 1) One-touch fittings in inch sizes are also available. For details, refer to page 2-3-56.

Note 2) Can be changed to side ported configuration.

Note 3) An optional specification for special wiring is available to increase the maximum number of stations. Refer to page 2-3-54 for details.

Note 4) Except valves. For valve weight, refer to page 2-3-28.

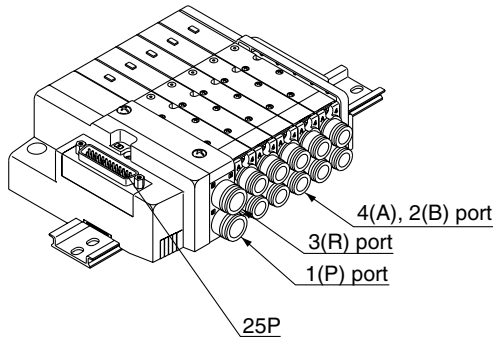

F kit

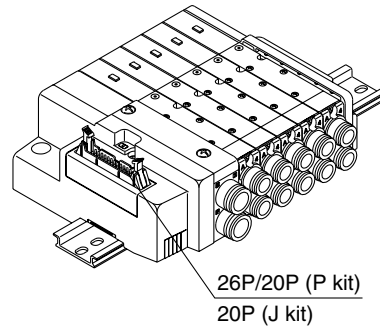

P kit J kit

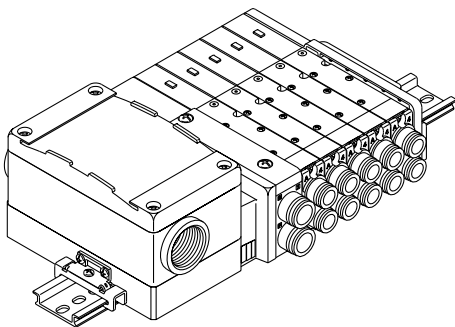

T kit

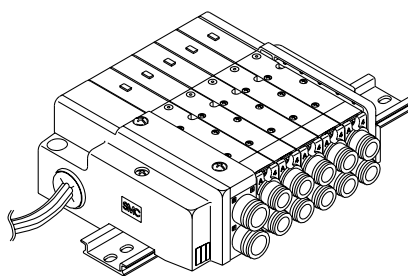

L kit

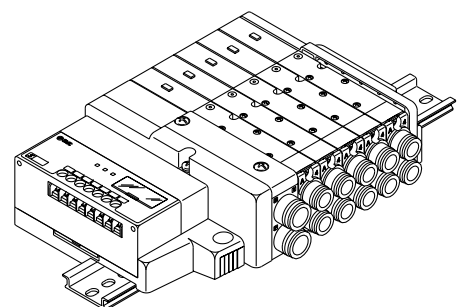

S kit

VQC

SQ

VQ0

VQ4

VQ5

VQZ

VQD

Series SQ2000

F Kit (D-sub connector kit)

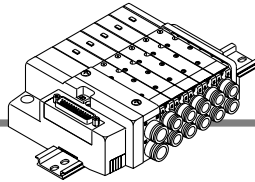

- Simplification and labor savings for wiring work can be achieved by using a D-sub connector for the electrical connection.
- Using connector for flat ribbon cable (25P) conforming to MIL standard permits the use of connectors put on the market and gives a wide interchangeability.
- Top or side entry for the connector can be changed freely, allowing later changes according to the mounting space.

Manifold Specifications

Series	Port location	Porting specifications		Maximum number of stations (16 as an option)
		1(P), 3(R)	4(A), 2(B)	
SQ2000	Side, Top	C10	C4, C6, C8	12 stations (16 as an option)

D-sub Connector (25 pin)

AXT100-DS25-015
030
050

(D-sub connector cable assemblies can be ordered with manifolds.)
Refer to manifold ordering.

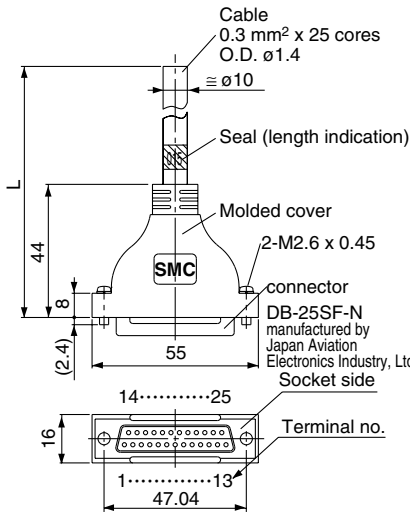

D-sub Connector Cable Assembly Terminal No.

Terminal number	Lead wire color	Dot marking
1	Black	None
2	Brown	None
3	Red	None
4	Orange	None
5	Yellow	None
6	Pink	None
7	Blue	None
8	Purple	White
9	Gray	Black
10	White	Black
11	White	Red
12	Yellow	Red
13	Orange	Red
14	Yellow	Black
15	Pink	Black
16	Blue	White
17	Purple	None
18	Gray	None
19	Orange	Black
20	Red	White
21	Brown	White
22	Pink	Red
23	Gray	Red
24	Black	White
25	White	None

D-sub Connector Cable Assembly (Option)

Cable length (L)	Assembly part no.	Note
1.5 m	AXT100-DS25-015	Cable
3 m	AXT100-DS25-030	0.3 mm ² x 25 cores
5 m	AXT100-DS25-050	

* For other commercial connectors, use a 25 pins type with female connector conforming to MIL-C-24308.

* Cannot be used for transfer wiring.

Electric Characteristics

Item	Characteristics
Conductor resistance Ω/km, 20°C	65 or less
Voltage limit VAC, 1 min.	1000
Insulation resistance MΩ/km, 20°C	5 or less

Note) The minimum bending radius for D-sub connector cables is 20 mm.

Connector manufacturers' example

- Fujitsu, Ltd.
- Japan Aviation Electronics Industry, Ltd.
- J.S.T. Mfg. Co., Ltd.
- Hirose Electric Co., Ltd.

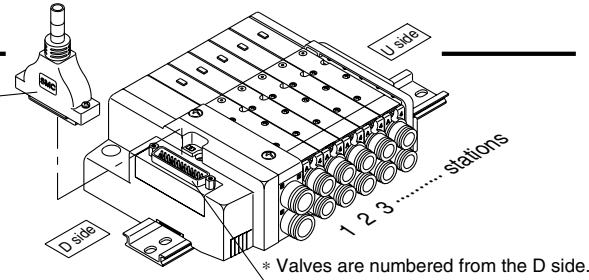

Electrical wiring specifications

D-sub connector

As the standard electrical wiring specifications, double wiring (connected to SOL. A and SOL. B) is adopted for the internal wiring of each station for 12 stations or less, regardless of valve and option types. Mixed single and double wiring is available as an option.
For details, refer to page 2-3-54.

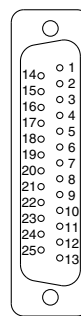

Connector terminal no.

Lead wire colors for D-sub connector assembly (AXT100-DS25-015)

	Terminal no.	Polarity	Lead wire color	Dot marking
1 station	SOL.A 1	(-) (+)	Black	None
	SOL.B 14	(-) (+)	Yellow	Black
2 stations	SOL.A 2	(-) (+)	Brown	None
	SOL.B 15	(-) (+)	Pink	Black
3 stations	SOL.A 3	(-) (+)	Red	None
	SOL.B 16	(-) (+)	Blue	White
4 stations	SOL.A 4	(-) (+)	Orange	None
	SOL.B 17	(-) (+)	Purple	None
5 stations	SOL.A 5	(-) (+)	Yellow	None
	SOL.B 18	(-) (+)	Gray	None
6 stations	SOL.A 6	(-) (+)	Pink	None
	SOL.B 19	(-) (+)	Orange	Black
7 stations	SOL.A 7	(-) (+)	Blue	None
	SOL.B 20	(-) (+)	Red	White
8 stations	SOL.A 8	(-) (+)	Purple	White
	SOL.B 21	(-) (+)	Brown	White
9 stations	SOL.A 9	(-) (+)	Gray	Black
	SOL.B 22	(-) (+)	Pink	Red
10 stations	SOL.A 10	(-) (+)	White	Black
	SOL.B 23	(-) (+)	Gray	Red
11 stations	SOL.A 11	(-) (+)	White	Red
	SOL.B 24	(-) (+)	Black	White
12 stations	SOL.A 12	(-) (+)	Yellow	Red
	SOL.B 25	(-) (+)	White	None
	COM 13	(+) (-)	Orange	Red

Positive common specifications Negative common specifications

Note) When using the negative common specifications, use valves for negative common.

Plug-in Unit Series SQ2000

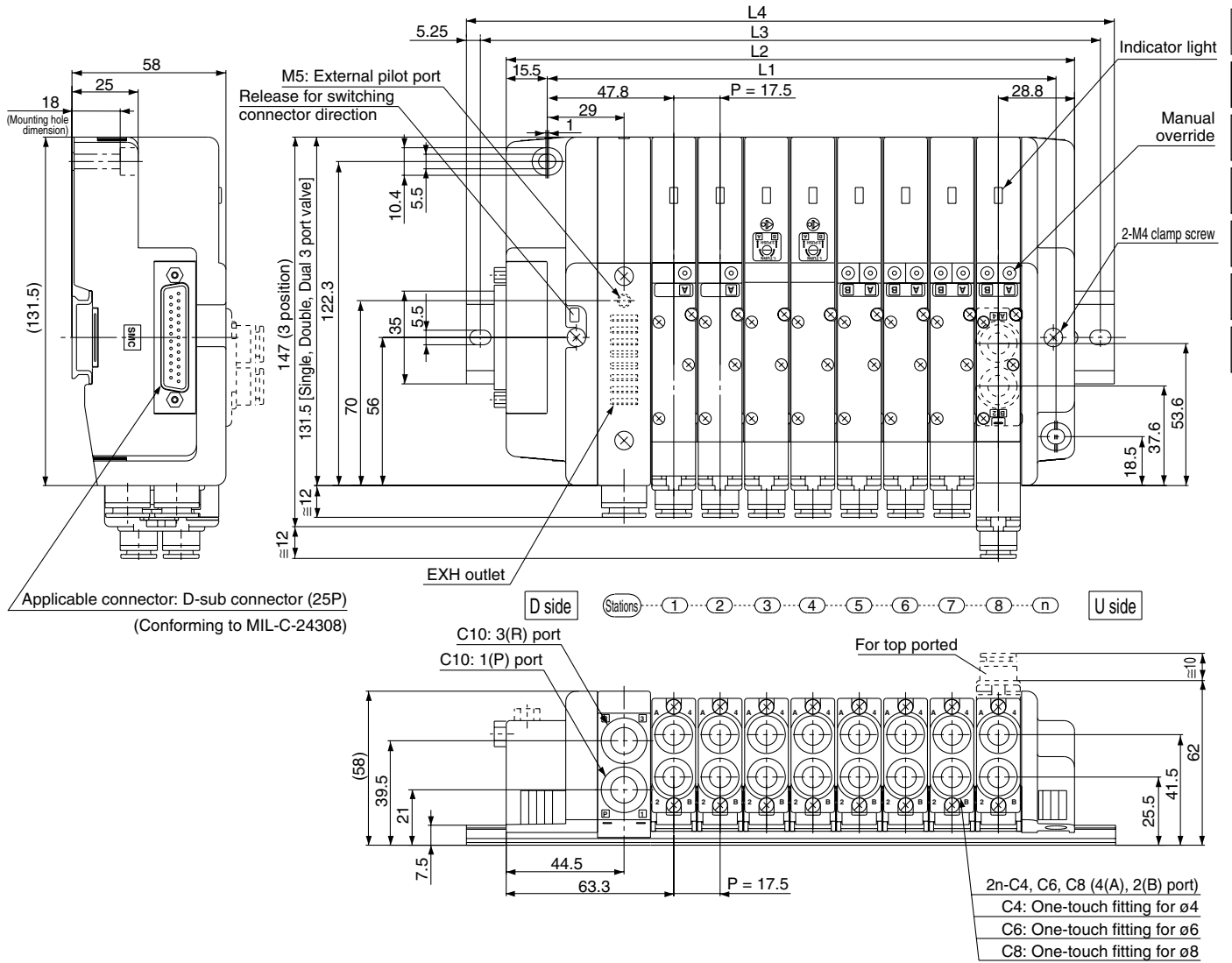

- VQC
- SQ
- VQ0
- VQ4
- VQ5
- VQZ
- VQD

Dimensions

Formula: $L1 = 17.5n + 52$, $L2 = 17.5n + 74.5$ n: Stations (Maximum 16 stations)

L	n	1	2	3	4	5	6	7	8	9	10	11	12	13	14	15	16
L1		69.5	87	104.5	122	139.5	157	174.5	192	209.5	227	244.5	262	279.5	297	314.5	332
L2		92	109.5	127	144.5	162	179.5	197	214.5	232	249.5	267	284.5	302	319.5	337	354.5
L3		112.5	137.5	150	175	187.5	200	225	237.5	262.5	275	287.5	312.5	325	350	362.5	375
L4		123	148	160.5	185.5	198	210.5	235.5	248	273	285.5	298	323	335.5	360.5	373	385.5

Manifold Option Parts for SQ2000

Blanking plate

SSQ2000-10A-3

It is used by attaching on the manifold block for being prepared for removing a valve for maintenance reasons or planning to mount a spare valve, etc.

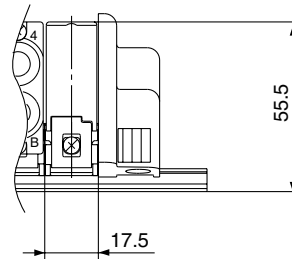
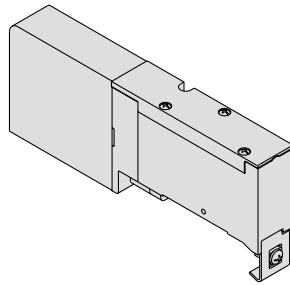

JIS Symbol

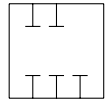

SUP/EXH block

SSQ2000-PR-3-C10-□

Option

Nil	Standard
R	External pilot specifications
S	Built-in silencer

Note) When specifying both options, indicate "RS".

* Specify the spacer mounting position on the manifold specification sheet.

For standard type manifolds, the SUP/EXH block is mounted on the D side. It is added to the manifold to increase SUP/EXH capacity.

* The number of SUP/EXH blocks that can be added is limited to two sets, one between manifold stations and another on the U side of the manifold due to the length of the internal lead wire.

* SUP/EXH blocks are not included in the number of manifold stations.

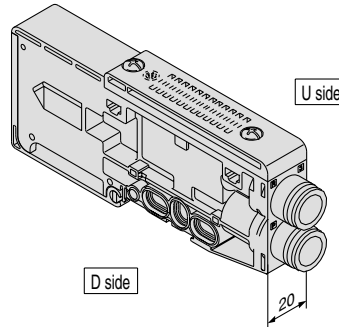

Description/Model		Stations				
		1	2	3	4	5
Valve	Single	●	●	●		
	:					
Option	SUP/EXH block				●	
	SSQ2000-PR-3-C10-□					

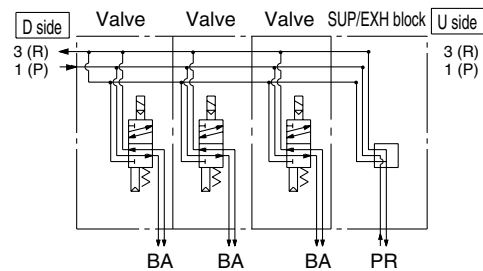

Individual SUP spacer

SSQ2000-P-3-C8

Port location

C8	Side ported
L8	Top ported

This is used as a supply port for different pressures when using different pressures in the same manifold (for one station).

Both sides of the station which is used with supply pressure from the individual SUP spacer are shut off. (Refer to application example.)

* Specify the spacer mounting position and SUP passage shut off positions on the manifold specification sheet. Two shut off positions are required per unit.

(Two pieces of SUP block plate that shut off the supply pressure are included with the individual SUP spacer, therefore, it is not necessary to order them separately.)

* Electrical wiring is also connected to the manifold station with the individual SUP spacer.

* By changing the fitting shown in the drawing and the block plates, the spacer's specification can be changed later (from the individual SUP spacer to the individual EXH spacer).

* The number of spacers is not limited when ordered with the manifold. However, when adding individual SUP spacers later, it is limited to two units, and another on the U side due to the length of the internal lead wire.

* Model no. with manifold block:

SSQ2000-P-3-C8-M
L8

Side ported

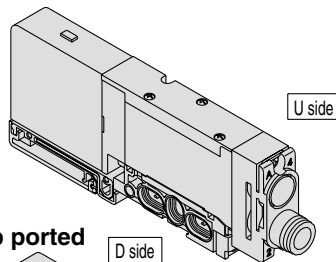

Top ported

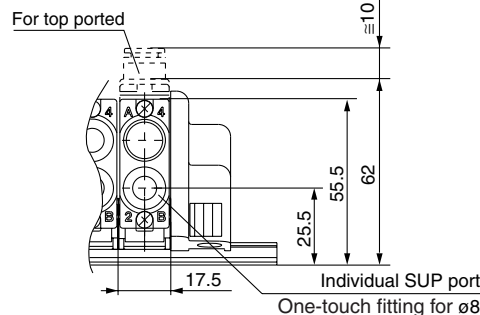
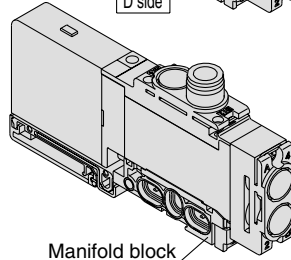

Description/Model		Stations				
		1	2	3	4	5
Valve	Single	●	●	●		
	:					
Option	Individual SUP spacer		●			
	SUP shut off position: Specify 2 positions.	●	●			

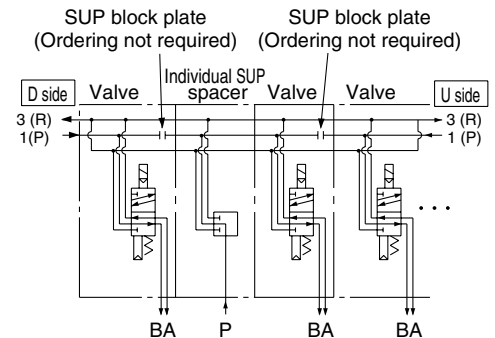

Series SQ1000/2000

Manifold Option Parts for SQ2000

Individual EXH spacer

SSQ2000-R-3-C8

•Port location

C8	Side ported
L8	Top ported

This is used to exhaust an individual valve when the exhaust from a valve interferes with other stations in the circuit (used for one station).

Both sides of the station which is to be individually exhausted are shut off. (Refer to application example.)

* Specify the spacer mounting position and EXH passage shut off positions on the manifold specification sheet. Two shut off positions are required per unit.

(Four pieces of EXH block plate that shut off the exhaust are included with the individual EXH spacer, therefore, it is not necessary to order them separately.)

* Electrical wiring is also connected to the manifold station with the individual EXH spacer.

* By changing the fitting shown in the drawing and the block plates, the spacer's specification can be changed later (from the individual EXH spacer to the individual SUP spacer).

* The number of spacers is not limited when ordered with the manifold. However, when adding individual EXH spacers later, it is limited to two units, one between manifold stations and another on the U side due to the length of the internal lead wire.

* Model no. with manifold block:

SSQ2000-R-3-C8-M
L8

Side ported

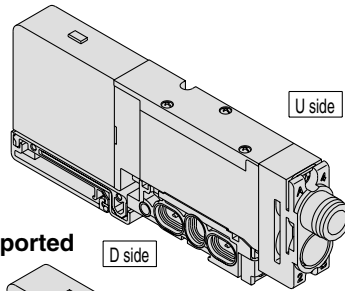

Top ported

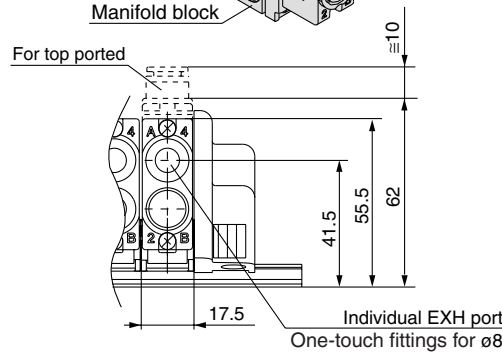
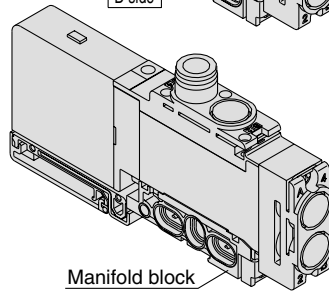

		Stations				
Description/Model		1	2	3	4	5
Valve	Single	●	●	●		
	⋮					
Option	Individual EXH spacer SSQ2000-R-3- <u>C8</u>		●			
	EXH shut off position: Specify 2 positions.	●		●		

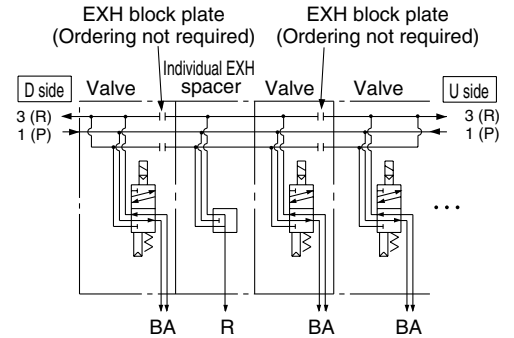

Individual SUP/EXH spacer

SSQ2000-PR1-3-C8

•Port location

C8	Side ported
L8	Top ported

This has both functions of the individual SUP and EXH spacers above. (Refer to application example.)

* Specify the spacer mounting position and SUP and EXH passage shut off positions on the manifold specification sheet. Two shut off positions each for SUP and EXH are required per unit.

[Block plates that shut off the SUP and EXH passages are included with the individual SUP/EXH spacer (2 pcs. of SUP block plate and 4 pcs. of EXH block plate).]

* Electrical wiring is also connected to the manifold station with the individual EXH spacer.

* By changing the fitting shown in the drawing and the block plates, the spacer's specification can be changed later.

* The number of spacers is not limited when ordered with the manifold. However, when adding individual SUP/EXH spacers later, it is limited to two units, one between manifold stations on the U side due to the length of the internal lead wire.

* Model no. with manifold block:

SSQ2000-PR1-3-C8-M
L8

Side ported

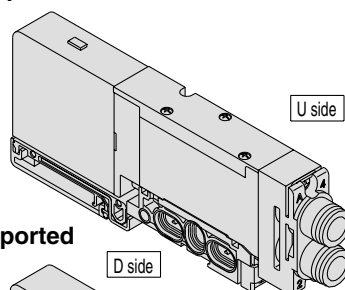

Top ported

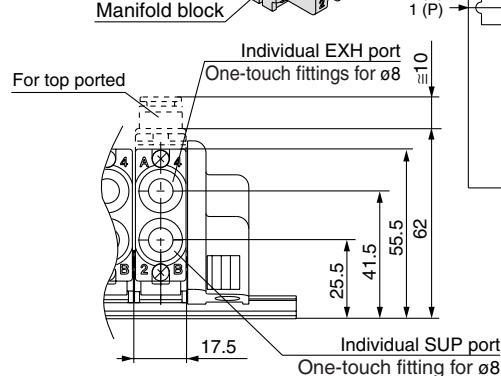
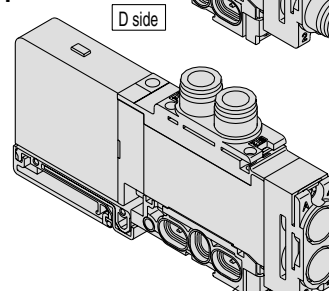

		Stations				
Description/Model		1	2	3	4	5
Valve	Single	●	●	●		
	⋮					
Option	Individual SUP/EXH spacer SSQ2000-PR1-3- <u>C8</u>		●			
	SUP shut off position: Specify 2 positions.	●		●		
	EXH shut off position: Specify 2 positions.	●		●		

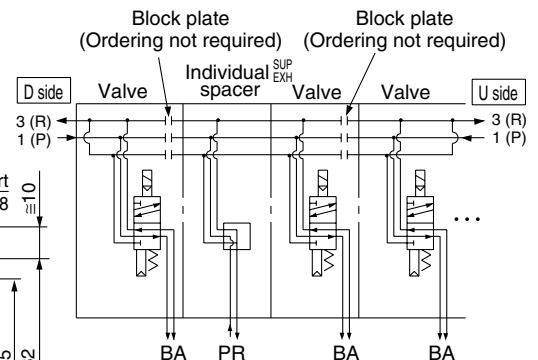

SUP block plate

SSQ1000-B-R

When supplying two different pressures, high and low, to one manifold, this is used between stations with different pressures. Also, it is used with an individual SUP spacer to shut off the air supply.

* Specify the station position on the manifold specification sheet.

<Shut off label>

When a SUP passage is shut off with a SUP block plate, a label is attached for external confirmation of the shut off position (one label each).

* Shut off labels are applied when SUP block plates are ordered with manifolds.

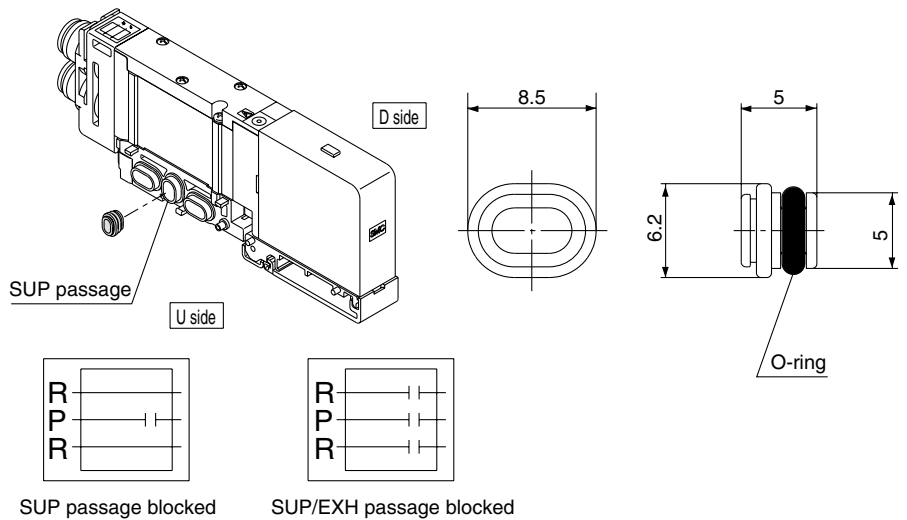

VQC
SQ
 VQ0
 VQ4
 VQ5
 VQZ
 VQD

EXH block plate

SSQ2000-B-R

When the exhaust from a valve interferes with other stations in the circuit, this is used between stations to separate exhausts. Also, it is used with an individual EXH spacer to shut off the exhaust of individual valves.

* Specify the station position on the manifold specification sheet.

<Shut off label>

When an EXH passage is shut off with an EXH block plate, a label is attached for external confirmation of the shut off position (one label each).

* Shut off labels are applied when EXH block plates are ordered with manifolds.

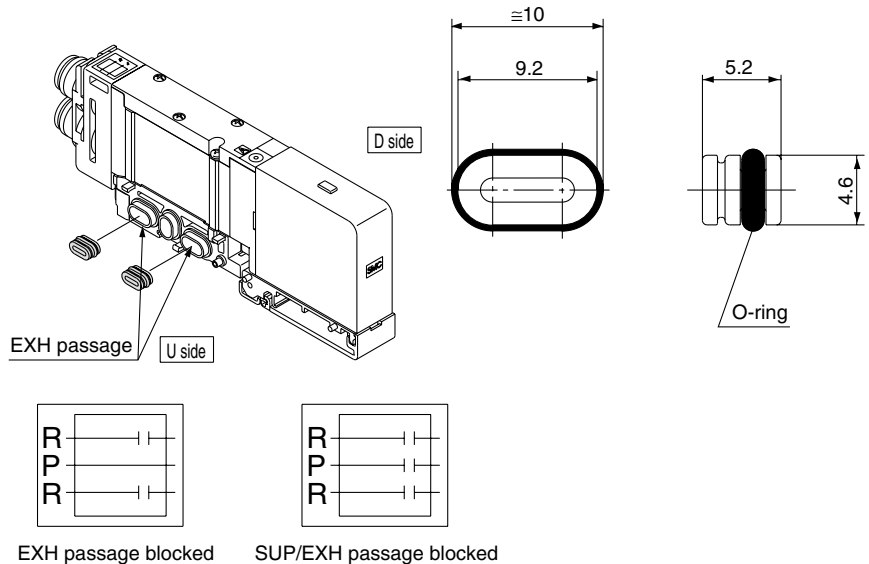

Back pressure check valve [-B]

SSQ2000-BP

This prevents cylinder malfunction caused by the exhaust from other valves. It is inserted into the R (EXH) port of the valve that is affected. It is especially effective when using single acting cylinders or exhaust center type solenoid valves.

* When installing back pressure check valves only on the stations required, enter the part number and specify the mounting stations on a manifold specification sheet.

* When installing back pressure check valves on all of the stations, indicate "B" at the end of the manifold part number.

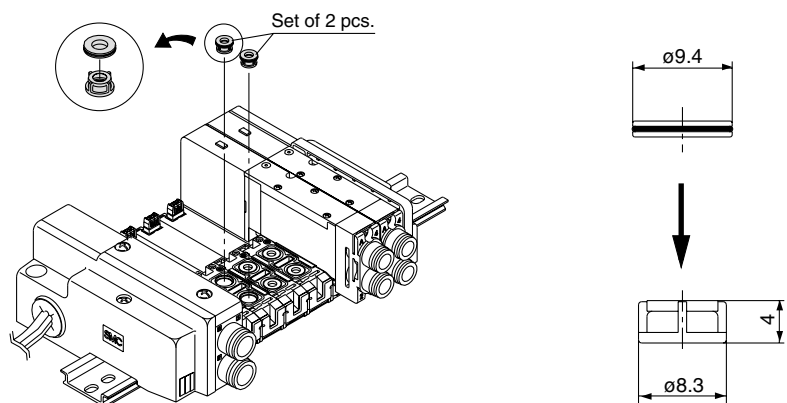

⚠ Caution

1. Although the back pressure check valve is an assembly part with a check valve mechanism, a small amount of air leakage is allowed. Therefore, take care not to restrict the exhaust air from the exhaust port.
2. The effective area of valves is about 20% less when the back pressure check valve is installed.

Series SQ1000/2000

Manifold Option Parts for SQ2000

Name plate [-N]

SSQ2000-N3- Stations (1 to maximum)

This is a clear resin plate for applying solenoid valve function description labels, etc.

To install, bend the plate slightly as shown and insert into the slots on the end plate side. Also, the plate is difficult to bend for manifolds with only a few stations, therefore, remove the silencer cover to install it.

* When ordering with manifolds, add "-N" at the end of the manifold number.

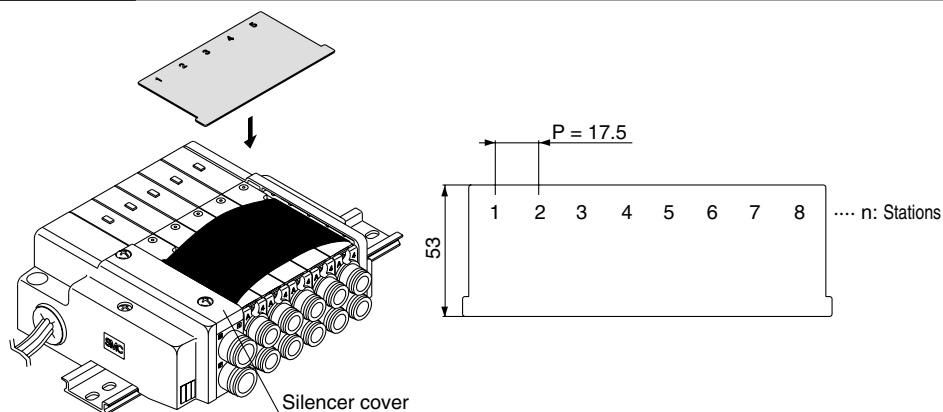

Blanking plug (For One-touch fitting)

04
06
08
10
KQ2P-

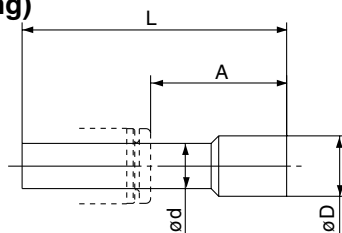
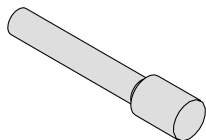

This is inserted into cylinder ports and SUP and EXH ports that are not used.

Purchasing order is available in units of 10 pieces.

Dimensions

Applicable fittings size ød	Model	A	L	D
4	KQ2P-04	16	32	6
6	KQ2P-06	18	35	8
8	KQ2P-08	20.5	39	10
10	KQ2P-10	22	43	12

Port plug

VVQZ2000-CP

This is used to close the cylinder ports when changing a 5 port valve to a 3 port valve.

* Add "A" or "B" at the end of the valve part number when ordering with valves.

Example) SQ2131-5-C8-A (N.O. specifications)

• 4 (A) port plug

Example) SQ2131-5-C8-B (N.C. specifications)

• 2 (B) port plug

Example) SQ2131-5-C8-B-M

(B port plug with manifold block)

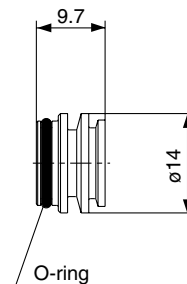
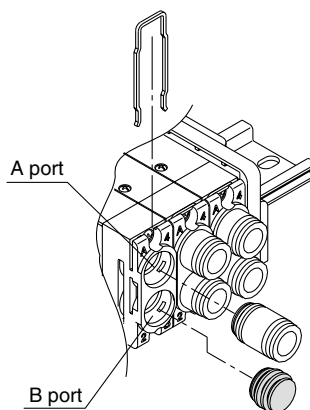

Direct EXH outlet, built-in silencer [-S]

The EXH outlet is placed on the top side of the manifold end plate. The built-in silencer provides highly effective noise reduction. (Noise reduction of 30 dB)



Note) Note that when excessive drainage occurs in the air supply, the drainage will be released along with the exhaust.

* Add "-S" at the end of the manifold part number when ordering with manifolds.

* For precautions on handling and how to replace elements, refer to page 2-3-5.

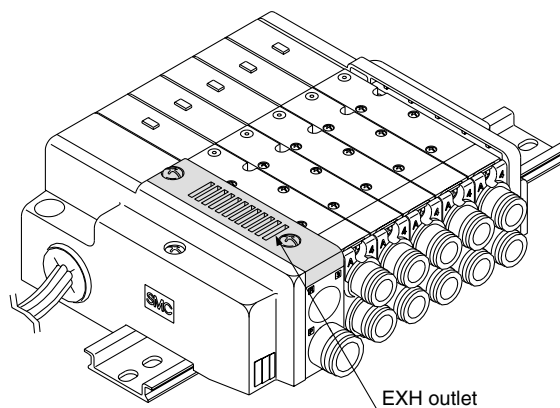

External pilot specifications [-R]

This can be used when the air pressure is 0.1 to 0.2 MPa lower than the minimum operating pressure of the solenoid valves or used for vacuum specifications.

Add "R" to the part numbers of manifolds and valves to indicate the external pilot specifications.

An M5 port will be installed on the top side of the manifold's SUP/EXH block.

● How to order valves (Example)

SQ2130 R -5-C6

External pilot specifications

● How to order manifold (Example)

* Indicate "R" for an option.

SS5Q23-08FD1-DR

External pilot specifications

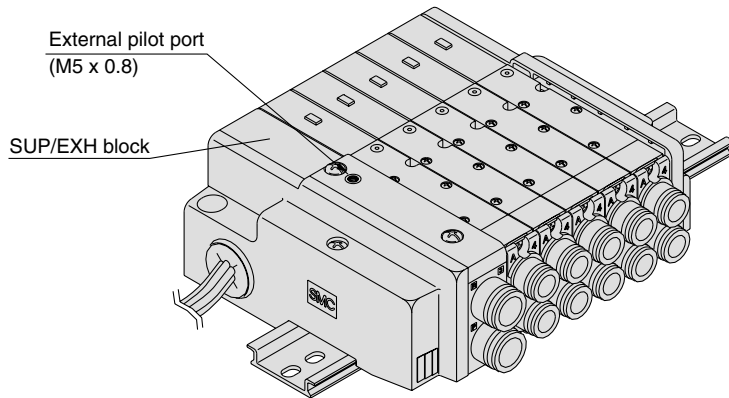

Note 1) Not applicable for dual 3 port valves.

Note 2) Indicate "RY" for low wattage types.

Note 3) Valves with the external pilot specifications have a pilot EXH with individual exhaust specifications and EXH can be pressurized. However, the pressure supplied from EXH should be 0.4 MPa or lower.

VQC

SQ

VQ0

VQ4

VQ5

VQZ

VQD

Dual flow fitting

SSQ2000-52A- C10

•Port size

C10	ø10
N11	ø3/8"

To drive a large bore cylinder, two valve stations are operated simultaneously to double the air flow. This fitting is used on the cylinder ports in this situation. Available sizes are ø10 and ø3/8" One-touch fittings.

* When ordering with valves, specify the valve part number without One-touch fitting and list without One-touch fitting and list the dual flow fitting part number.

Example) Valve part number (without One-touch fitting)

SQ2131-5 -C0 2 sets

* SSQ2000- 52A - C10 1 set

N11

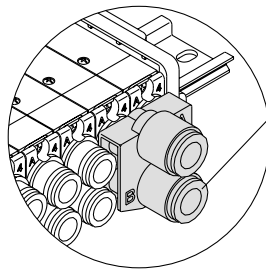

C10: One-touch fitting for ø10

N11: One-touch fitting for ø3/8"

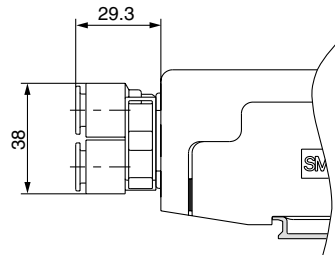
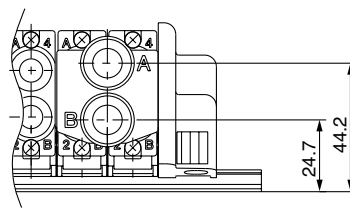

Silencer (For EXH port)

This is inserted into the centralized type EXH port (One-touch fitting).

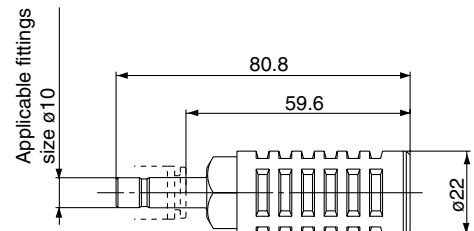
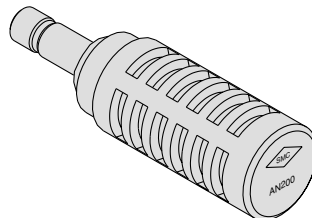

Specifications

Series	Model	Effective area (mm ²) (Cv factor)	Noise reduction (dB)
SQ2000	AN200-KM10	26 (1.4)	30

Series SQ1000/2000

Manifold Option Parts for SQ1000/SQ2000

Special Wiring Specifications

In the internal wiring of F kit, P kit, J kit, T kit and S kit, double wiring (connected to SOL. A and SOL. B) is adopted for each station regardless of the valve and option types. Mixed single and double wiring is available as an option.

1. How to Order

Indicate option symbol “-K” in the manifold part number and be sure to specify station positions for single or double wiring on the manifold specification sheet. Also, specify wiring for spare connectors.

(Up to two spare connectors are included depending on the remaining number of connector pins. When the wiring for the spare connectors is not specified, they will be wired according to “Spare Connector Wiring” on page 2-3-57.)

Example) **SS5Q13 - 09 FD0 - DKS**

Others, option symbols: to be indicated alphabetically.

2. Wiring specifications

Connector terminal numbers are connected from solenoid station 1 on the A side in the order indicated by the arrows without skipping any terminal numbers.

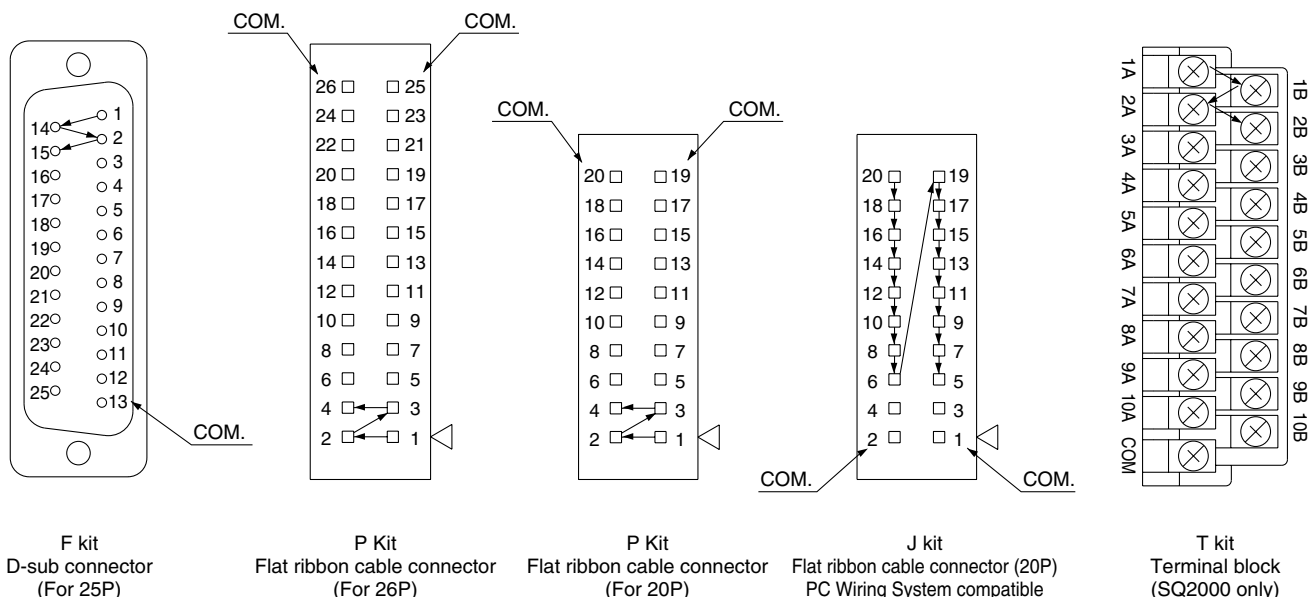

For S kit (serial transmission kit), refer to pages 2-3-20 and 2-3-40.

3. Maximum stations

The maximum number of manifold stations is determined by the number of solenoids. Count one point for a single solenoid type and two points for a double solenoid type. Determine the number of stations so that the total number of solenoids is no more than the maximum points in the table below.

Kit	F kit (D-sub connector)	P kit (Flat ribbon cable connector)		J kit Flat ribbon cable PC Wiring System compatible	T kit (Terminal block) SQ2000 only*	S kit (Serial)
Type	FD□ 25P	PD□ 26P	PDC 20P	JD0 20P	TD0	SD□
Max. points	24 points	24 points	18 points	16 points	20 points	16 points

Note) Maximum stations SQ1000: 24 stations
SQ2000: 16 stations

Special DIN Rail Length (DIN rail mounting (-D) only)

The standard DIN rail provided is approximately 30 mm longer than the overall length of the manifold with a specified number of stations. The following options are also available.

● DIN rail length longer than the standard type (for stations to be added later, etc.)

In the manifold part number, specify “-D” for the manifold mounting symbol and add the number of required stations after the symbol.

Example) **SS5Q13-08FD0-D09BNK**



● Ordering DIN rail only

DIN rail part number

AXT100-DR-n



Note) For “n”, enter a number from the “No.” line in the table below. For L dimension, refer to the dimensions of each kit.

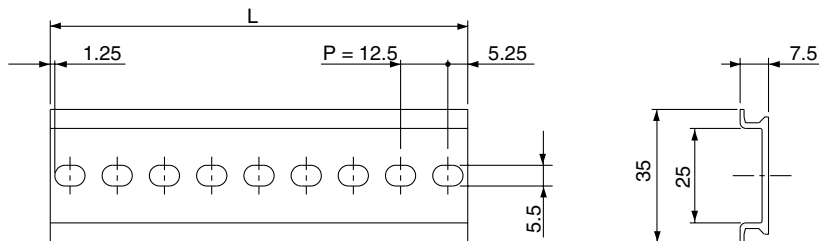

L Dimension

$$L = 12.5 \times n + 10.5$$

No.	1	2	3	4	5	6	7	8	9	10
L dimension	23	35.5	48	60.5	73	85.5	98	110.5	123	135.5
No.	11	12	13	14	15	16	17	18	19	20
L dimension	148	160.5	173	185.5	198	210.5	223	235.5	248	260.5
No.	21	22	23	24	25	26	27	28	29	30
L dimension	273	285.5	298	310.5	323	335.5	348	360.5	373	385.5
No.	31	32	33	34	35	36	37	38	39	40
L dimension	398	410.5	423	435.5	448	460.5	473	485.5	498	510.5

Direct Mounting Style (-E)

Manifold is mounted by using mounting holes of both sides of the manifold. DIN rail is not sticking out of the edge of end plate.

SQ1000

Mounting hole (For M4)

Mounting hole (For M4)

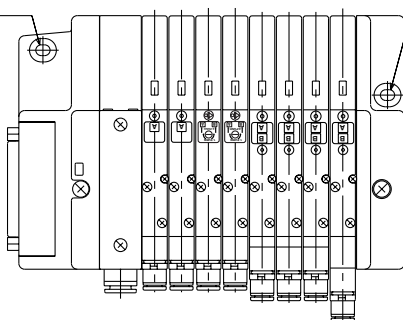

SQ2000

Mounting hole (For M5)

Mounting hole (For M5)

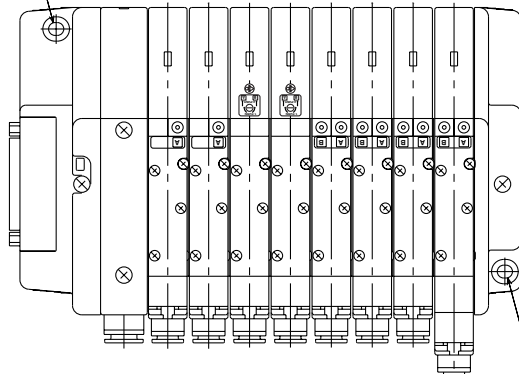

Series SQ1000/2000

Manifold Option for SQ1000/SQ2000

Negative Common Specifications

The following valve part numbers are for negative common specifications. Manifold part numbers are the same as the standard except L kit. Also, negative COM specifications are not available for the S kit.

● How to order negative COM valves (Example)

SQ1130 N -5-C6

• Negative common specifications

● How to order negative COM manifold (Example)

SS5Q13 -08LD1 N -DIN

Stations

Kit type

Option

DIN rail mounting style

• Negative common specifications

Inch-size One-touch Fittings

For One-touch fittings in inch sizes, use the following part numbers. Also, the color of the release button is orange.

● How to order valves (Example)

SQ1130- 5 - N7

Port location

Cylinder port

Port location		Symbol	N1	N3	N7	N9
Nil	Side ported	Applicable tubing O.D. (Inch)	ø1/8"	ø5/32"	ø1/4"	ø5/16"
L	Top ported	4(A), 2(B) port	●	●	●	—
			—	●	●	●

● How to order manifold (Example)

Add "00T" at the end of the part number.

SS5Q13-08FD0 - DN - 00T

• 1 (P), 3 (R) port in inch size
 { SQ1000: ø5/16" (N9)
 { SQ2000: ø3/8" (N11)

How to Add Manifold Stations for SQ1000/SQ2000

1. Using Spare Connector to Add Stations

As shown in the table below, wiring specifications for spare connectors are based on to the remaining number of connector pins (remaining number of pins against the maximum number of solenoids for each kit.)
The following steps are for using spare connectors to add stations.

Spare Connector Wiring

Remaining connector pins	4 pins or more	3 pins	2 pins	1 pin	0 pin
Spare connector wiring	2 for double wiring	1 for double wiring (on the low no. station side) 1 for single wiring	1 for double wiring	1 for single wiring	None

What to order

- Valves with manifold block (refer to pages 2-3-7 and 2-3-25) or the manifold blocks (Refer to page 2-3-58)>

Steps for adding stations

- Loosen the clamp screw on the U side end plate and open the manifold.
- Mount the manifold block to be added.
- Open the junction cover and attach the spare connector. Match the station position of the added station and the spare connector station number.
- Press on the end plate to eliminate any space between the manifold blocks and tighten the clamp screw.
(Proper tightening torque: 0.8 to 1.0 N·m)
Note 1) Order a manifold block with lead wire for the L kit because a spare connector is not included with the kit. (Refer to page 2-3-58.)
Note 2) Do not let the lead wires get caught between manifolds, or when closing the junction cover.

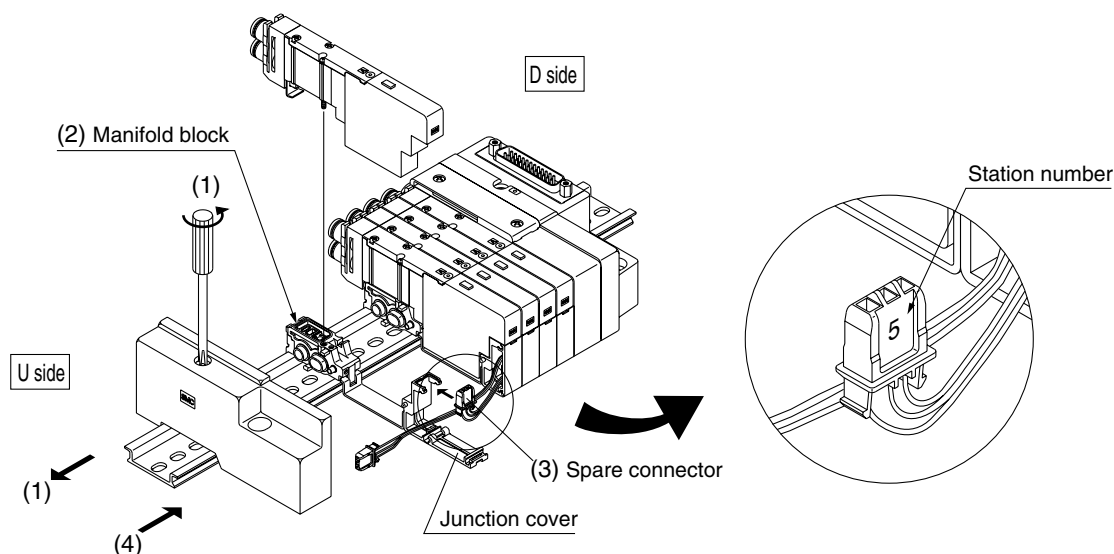

VQC

SQ

VQ0

VQ4

VQ5

VQZ

VQD

Series SQ1000/2000

How to Add Manifold Stations for SQ1000/SQ2000

2. Adding Stations Without Required Spare Connectors

Spare connectors for 2 stations are initially included. However, to add 3 or more stations, order manifold blocks with lead wire in the tables below.

How to Order Manifold Blocks with Lead Wire

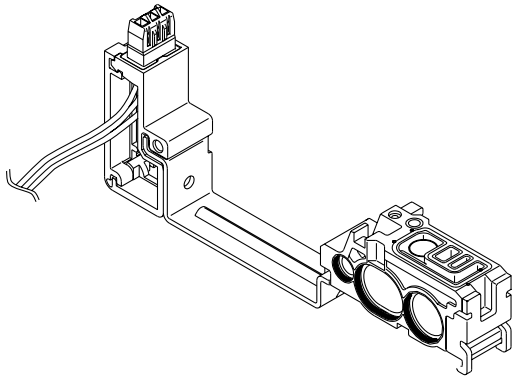
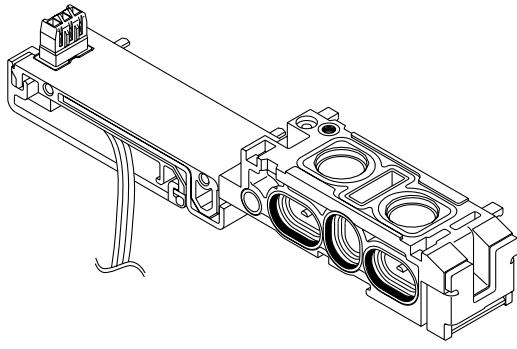
SQ1000	SQ2000																																																																				
																																																																					
<p>SSQ1000-1A-3-FS-03 </p> <p>Lead wire type ●</p> <table border="1" style="width: 100%; border-collapse: collapse;"> <tr><td style="width: 10%; text-align: center;">F0</td><td>Without lead wire (for using spare connectors to add stations)</td></tr> <tr><td style="text-align: center;">FS</td><td>F kit (D-sub connector kit) Single wiring</td></tr> <tr><td style="text-align: center;">FW</td><td>F kit (D-sub connector kit) Double wiring</td></tr> <tr><td style="text-align: center;">PS</td><td>P, J kit (Flat ribbon cable kit) Single wiring</td></tr> <tr><td style="text-align: center;">PW</td><td>P, J kit (Flat ribbon cable kit) Double wiring</td></tr> <tr><td style="text-align: center;">L0</td><td>L kit (Lead wire kit) Lead wire length 0.6 m</td></tr> <tr><td style="text-align: center;">L1</td><td>L kit (Lead wire kit) Lead wire length 1.5 m</td></tr> <tr><td style="text-align: center;">L2</td><td>L kit (Lead wire kit) Lead wire length 3.0 m</td></tr> <tr><td style="text-align: center;">SS</td><td>S kit (Serial transmission kit) Single wiring</td></tr> <tr><td style="text-align: center;">SW</td><td>S kit (Serial transmission kit) Double wiring</td></tr> </table> <p>Applicable stations ●</p> <table border="1" style="width: 100%; border-collapse: collapse;"> <tr><td style="width: 10%; text-align: center;">01</td><td>1 station</td></tr> <tr><td style="text-align: center;">⋮</td><td>⋮</td></tr> <tr><td style="text-align: center;">24</td><td>24 station</td></tr> </table> <p>Option ●</p> <table border="1" style="width: 100%; border-collapse: collapse;"> <tr><td style="width: 10%; text-align: center;">Nil</td><td>None</td></tr> <tr><td style="text-align: center;">B</td><td>Back pressure check valve</td></tr> <tr><td style="text-align: center;">R</td><td>External pilot specifications</td></tr> </table> <p>Note 1) No symbol required for "F0". Note 2) S kit is from 01 to 16</p> <p>Note) Enter "-BR" for both options.</p>	F0	Without lead wire (for using spare connectors to add stations)	FS	F kit (D-sub connector kit) Single wiring	FW	F kit (D-sub connector kit) Double wiring	PS	P, J kit (Flat ribbon cable kit) Single wiring	PW	P, J kit (Flat ribbon cable kit) Double wiring	L0	L kit (Lead wire kit) Lead wire length 0.6 m	L1	L kit (Lead wire kit) Lead wire length 1.5 m	L2	L kit (Lead wire kit) Lead wire length 3.0 m	SS	S kit (Serial transmission kit) Single wiring	SW	S kit (Serial transmission kit) Double wiring	01	1 station	⋮	⋮	24	24 station	Nil	None	B	Back pressure check valve	R	External pilot specifications	<p>SSQ2000-1A-3-FS-03 </p> <p>Lead wire type ●</p> <table border="1" style="width: 100%; border-collapse: collapse;"> <tr><td style="width: 10%; text-align: center;">F0</td><td>Without lead wire (for using spare connectors to add stations)</td></tr> <tr><td style="text-align: center;">FS</td><td>F kit (D-sub connector kit) Single wiring</td></tr> <tr><td style="text-align: center;">FW</td><td>F kit (D-sub connector kit) Double wiring</td></tr> <tr><td style="text-align: center;">PS</td><td>P, J kit (Flat ribbon cable kit) Single wiring</td></tr> <tr><td style="text-align: center;">PW</td><td>P, J kit (Flat ribbon cable kit) Double wiring</td></tr> <tr><td style="text-align: center;">TS</td><td>T kit (Terminal block kit) Single wiring</td></tr> <tr><td style="text-align: center;">TW</td><td>T kit (Terminal block kit) Double wiring</td></tr> <tr><td style="text-align: center;">L0</td><td>L kit (Lead wire kit) Lead wire length 0.6 m</td></tr> <tr><td style="text-align: center;">L1</td><td>L kit (Lead wire kit) Lead wire length 1.5 m</td></tr> <tr><td style="text-align: center;">L2</td><td>L kit (Lead wire kit) Lead wire length 3.0 m</td></tr> <tr><td style="text-align: center;">SS</td><td>S kit (Serial transmission kit) Single wiring</td></tr> <tr><td style="text-align: center;">SW</td><td>S kit (Serial transmission kit) Double wiring</td></tr> </table> <p>Applicable stations ●</p> <table border="1" style="width: 100%; border-collapse: collapse;"> <tr><td style="width: 10%; text-align: center;">01</td><td>1 station</td></tr> <tr><td style="text-align: center;">⋮</td><td>⋮</td></tr> <tr><td style="text-align: center;">16</td><td>16 stations</td></tr> </table> <p>Note) No symbol required for "F0".</p> <p>Option ●</p> <table border="1" style="width: 100%; border-collapse: collapse;"> <tr><td style="width: 10%; text-align: center;">Nil</td><td>None</td></tr> <tr><td style="text-align: center;">B</td><td>Back pressure check valve</td></tr> <tr><td style="text-align: center;">R</td><td>External pilot specifications</td></tr> </table> <p>Note) Enter "-BR" for both options.</p>	F0	Without lead wire (for using spare connectors to add stations)	FS	F kit (D-sub connector kit) Single wiring	FW	F kit (D-sub connector kit) Double wiring	PS	P, J kit (Flat ribbon cable kit) Single wiring	PW	P, J kit (Flat ribbon cable kit) Double wiring	TS	T kit (Terminal block kit) Single wiring	TW	T kit (Terminal block kit) Double wiring	L0	L kit (Lead wire kit) Lead wire length 0.6 m	L1	L kit (Lead wire kit) Lead wire length 1.5 m	L2	L kit (Lead wire kit) Lead wire length 3.0 m	SS	S kit (Serial transmission kit) Single wiring	SW	S kit (Serial transmission kit) Double wiring	01	1 station	⋮	⋮	16	16 stations	Nil	None	B	Back pressure check valve	R	External pilot specifications
F0	Without lead wire (for using spare connectors to add stations)																																																																				
FS	F kit (D-sub connector kit) Single wiring																																																																				
FW	F kit (D-sub connector kit) Double wiring																																																																				
PS	P, J kit (Flat ribbon cable kit) Single wiring																																																																				
PW	P, J kit (Flat ribbon cable kit) Double wiring																																																																				
L0	L kit (Lead wire kit) Lead wire length 0.6 m																																																																				
L1	L kit (Lead wire kit) Lead wire length 1.5 m																																																																				
L2	L kit (Lead wire kit) Lead wire length 3.0 m																																																																				
SS	S kit (Serial transmission kit) Single wiring																																																																				
SW	S kit (Serial transmission kit) Double wiring																																																																				
01	1 station																																																																				
⋮	⋮																																																																				
24	24 station																																																																				
Nil	None																																																																				
B	Back pressure check valve																																																																				
R	External pilot specifications																																																																				
F0	Without lead wire (for using spare connectors to add stations)																																																																				
FS	F kit (D-sub connector kit) Single wiring																																																																				
FW	F kit (D-sub connector kit) Double wiring																																																																				
PS	P, J kit (Flat ribbon cable kit) Single wiring																																																																				
PW	P, J kit (Flat ribbon cable kit) Double wiring																																																																				
TS	T kit (Terminal block kit) Single wiring																																																																				
TW	T kit (Terminal block kit) Double wiring																																																																				
L0	L kit (Lead wire kit) Lead wire length 0.6 m																																																																				
L1	L kit (Lead wire kit) Lead wire length 1.5 m																																																																				
L2	L kit (Lead wire kit) Lead wire length 3.0 m																																																																				
SS	S kit (Serial transmission kit) Single wiring																																																																				
SW	S kit (Serial transmission kit) Double wiring																																																																				
01	1 station																																																																				
⋮	⋮																																																																				
16	16 stations																																																																				
Nil	None																																																																				
B	Back pressure check valve																																																																				
R	External pilot specifications																																																																				

3. Connection Method (Refer to page 2-3-57 regarding the steps for adding stations to a manifold block.)

Connect the round terminal of the red lead wire to the common terminal inside the junction cover.

(1) Connecting common terminals

Connect lead wire assemblies included with manifold blocks as follows.

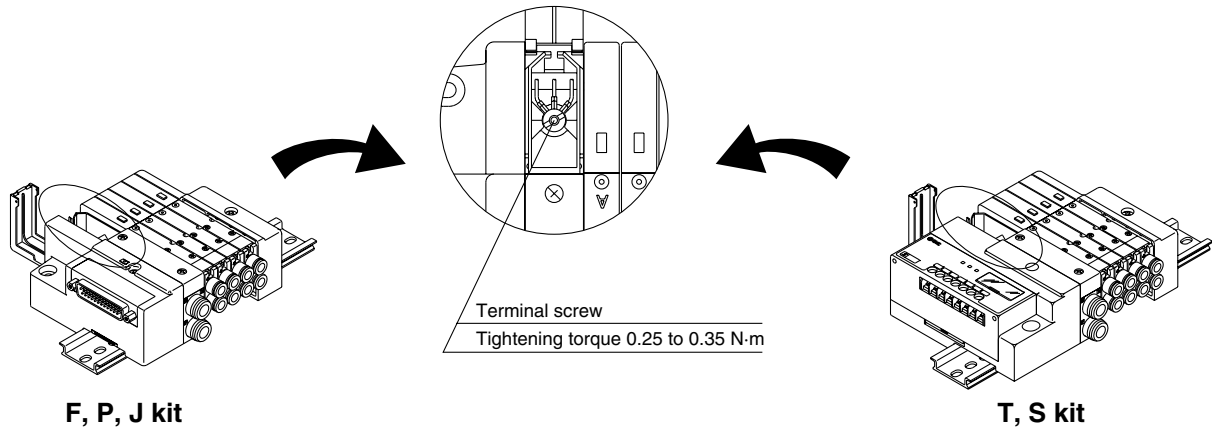

VQC

SQ

VQ0

VQ4

VQ5

VQZ

VQD

(2) Pulling out connector

Pull out the connector to connect the lead wire.

- For F, P, and J kits, pull out and remove the housing while pressing down hard on the hook with a flat head screwdriver, etc. Remove the manual lever and lead wire cover, and pull out the connector.
- For T kits, remove the screws and pull out the terminal block.
- For S kits, remove the screws and pull out the connector.

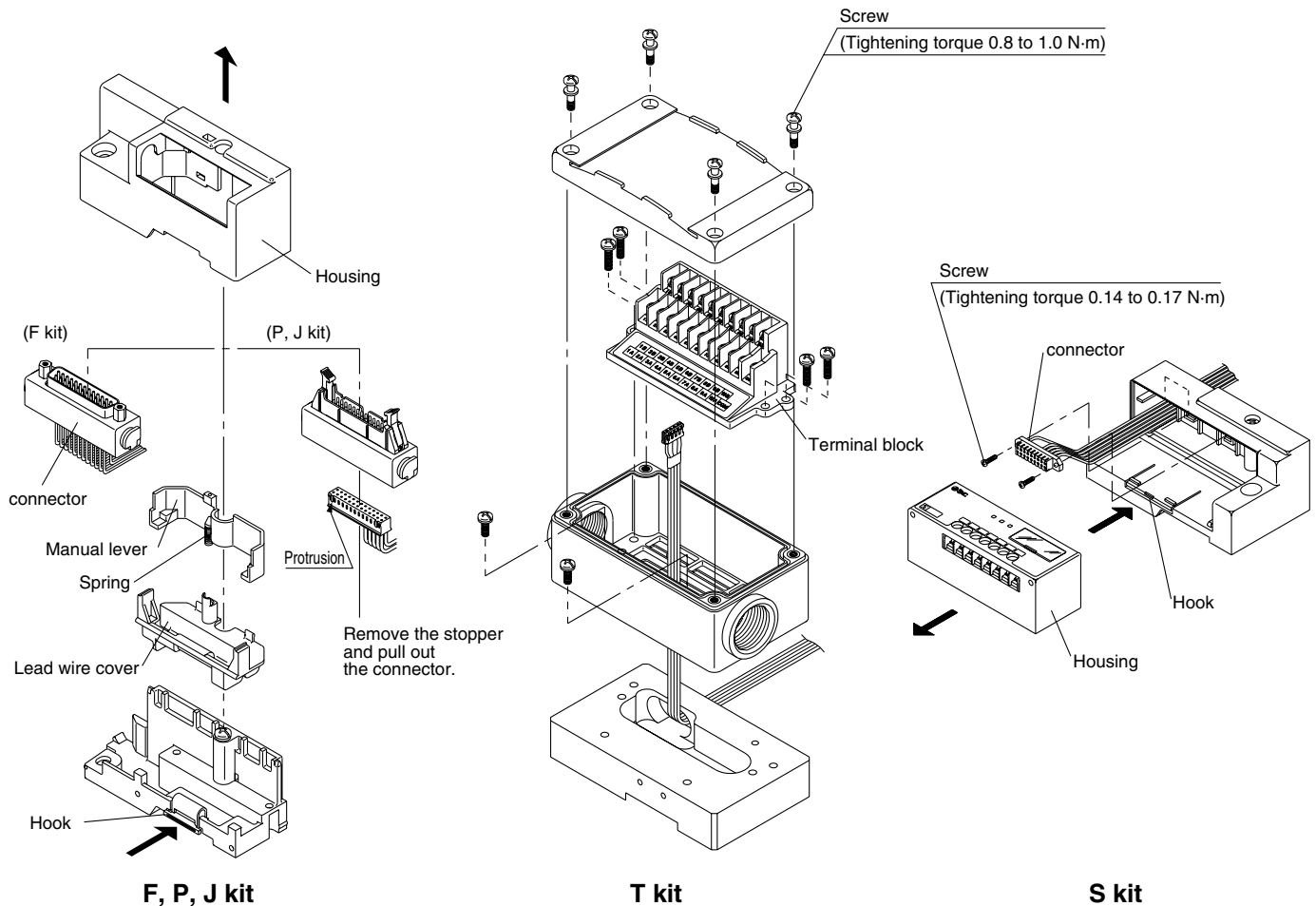

Series SQ1000/2000

How to Add Manifold Stations for SQ1000/SQ2000

(3) Connect the black and white lead wire pins to the positions shown below in accordance with each kit.

- ⚠ Caution**
1. After inserting the pin, confirm that the pin hook is locked by lightly pulling the lead wire.
 2. Do not pull the lead wire forcefully when connecting. Also, take care that lead wires do not get caught between manifolds or when closing the junction cover.

Wiring (F kit: D-sub connector kit)

Procedure) Based on the manifold specifications, station 1 of SOL.A (black wire) will be terminal number 1 of the D-sub connector, and for station 2 and thereafter, connect black wires, then white wires in the order as shown below by the arrows.

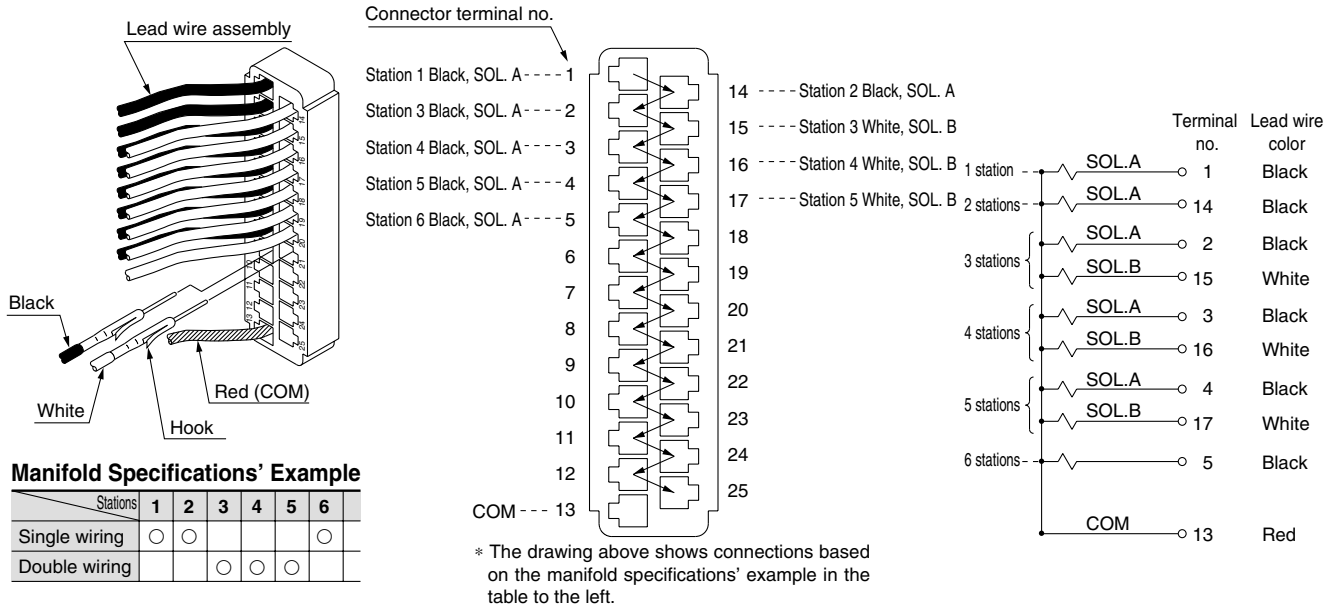

Wiring (P kit: Flat ribbon cable kit)

Procedure) Based on the manifold specifications, station 1 of SOL.A (black wire) will be terminal number 1 of the D-sub connector, and for station 2 and thereafter, connect black wires, then white wires in the order as shown below by the arrows.

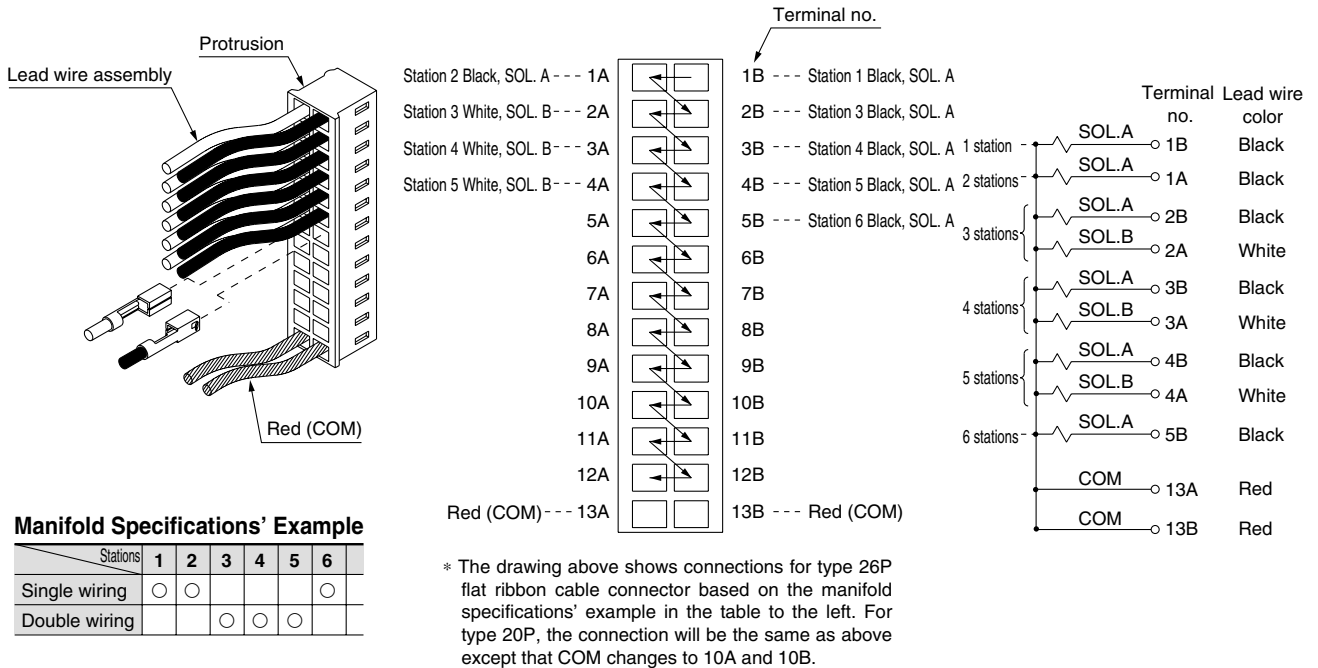

Series SQ1000/2000

Exploded View of Manifold: SQ2000 (Plug-in Type Manifold) SS5Q23

(F, P, J, T, L, S kit)

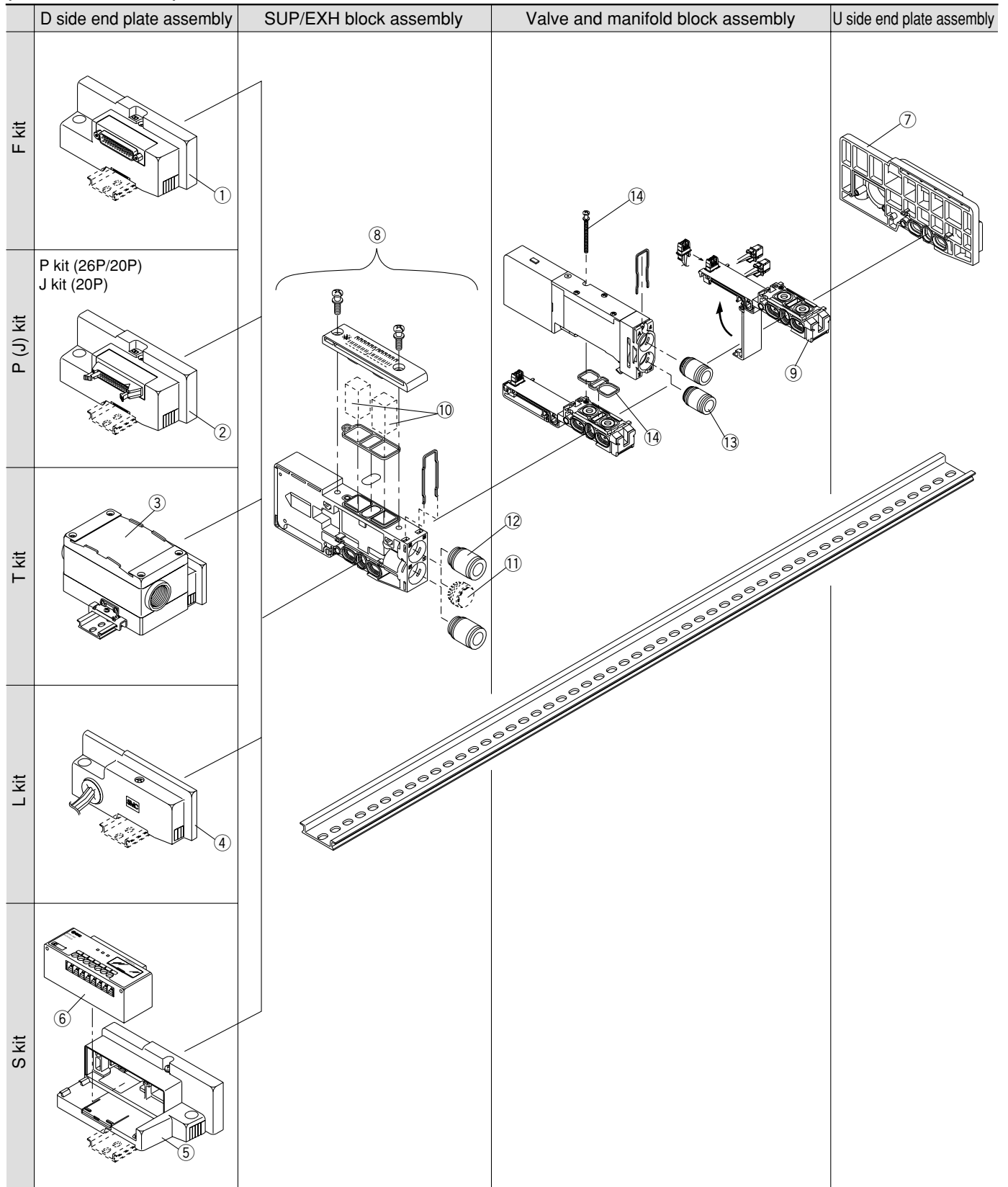

Manifold Spare Parts



Refer to pages 2-3-58 to 62 of "How to Add Manifold Stations" regarding the mounting of each spare parts.

<① ② ③ ④ ⑤ D side end plate assemblies>

SSQ2000 – 3A – 3

Manifold mounting

Nil	DIN rail mount style
E	Direct mount style

Electrical entry

F	F kit	①
P	P kit (26P)	②
PC	P kit (20P)	
J	J kit (20P)	③
Nil	L kit	
S	S kit	④

Wiring specifications

O	Without lead wire
S	Single wiring
W	Double wiring

Stations

01	For 1 station
⋮	⋮
16	For 16 stations

Note) The maximum number of stations will be different depending on the wiring

<⑥ SI unit>

Manifold	No.	Description
SDF kit	EX140-SUW1	NKE Corp.: Uni-wire System (16 output points)
SDH kit	EX140-SUH1	NKE Corp.: Uni-wire H System (16 output points)
SDJ1 kit	EX140-SSL1	SUNX Corp.: S-LINK System (16 output points)
SDJ2 kit	EX140-SSL2	SUNX Corp.: S-LINK System (8 output points)
SDQ kit	EX140-SDN1	DeviceNet, CompoBus/D (OMRON Corp.) (16 output points)
SDR1 kit	EX140-SCS1	OMRON Corp.: CompoBus/System (16 output points)
SDR2 kit	EX140-SCS2	OMRON Corp.: CompoBus/System (8 output points)
SDV kit	EX140-SMJ1	Mitsubishi Electric Corp.: CC-LINK System (16 output points)

<⑦ U side end plate assembly>

(For F, P, J, T, S kit)

SSQ2000 – 2A – 3

(For L kit)

SSQ2000 – 2A – 3

Manifold mounting

Nil	DIN rail mount style
E	Direct mount style

<⑧ SUP/EXH block assembly>

SSQ2000 – PR – 3

Port size

C8	One-touch fitting for ø8
C10	One-touch fitting for ø10
N9	One-touch fitting for ø5/16"
N11	One-touch fitting for ø3/8"

Option

Nil	Common exhaust type
R	External pilot
S	Built-in silencer, direct exhaust

Note) Enter "-RS" for both options.

<⑨ Manifold block assembly>

SSQ2000 – 1A – 3

Lead wire type

F0	Without lead wire
FS	F kit: D-sub connector kit Single wiring
FW	F kit: D-sub connector kit Double wiring
PS	P kit: Flat ribbon cable kit Single wiring
	J kit: PC Wiring System compatible Single wiring
PW	P kit: Flat ribbon cable kit Double wiring
	J kit: PC Wiring System compatible Double wiring
TS	T kit: Terminal block kit Single wiring
TW	T kit: Terminal block kit Double wiring
L0	L kit: Lead wire kit Lead wire length 0.6 m
L1	L kit: Lead wire kit Lead wire length 1.5 m
L2	L kit: Lead wire kit Lead wire length 3 m
SS	S kit: Serial transmission kit Single wiring
SW	S kit: Serial transmission kit Double wiring

Option

Nil	None
B	Back pressure check valve
R	External pilot specifications

Note) Enter "-BR" for both options.

Applicable stations

01	Station 1
⋮	⋮
16	Station 16

Note 1) No symbol required for "F0".

<⑩ Element>

SSQ2000 – SE

Note) Part number for a 10 piece set of element.
For replacement procedure, refer to page 2-3-5.

<⑪ Port plug>

VVQZ3000 – CP

<⑫ Fitting assembly>

(For P, R port)

VVQ2000 – 51A – C8

Port size

C8	One-touch fitting for ø8
C10	One-touch fitting for ø10
N9	One-touch fitting for ø5/16"
N11	One-touch fitting for ø3/8"

Note) Purchasing order is available in units of 10 pieces

<⑬ Fitting assembly>

(For cylinder port)

VVQ1000 – 51A – C4

Port size

C4	One-touch fitting for ø4
C6	One-touch fitting for ø6
C8	One-touch fitting for ø8
N3	One-touch fitting for ø5/32"
N7	One-touch fitting for ø1/4"
N9	One-touch fitting for ø5/16"
01	Rc 1/8 thread

Note) Purchasing order is available in units of 10 pieces

<⑭ Gasket and screw assembly>

SQ2000 – GS

Note) Part number for 10 pieces each of gaskets and screws.

VQC

SQ

VQ0

VQ4

VQ5

VQZ

VQD