

Serial Wiring with Input/Output Unit

Series *EX250*

IP67 compliant

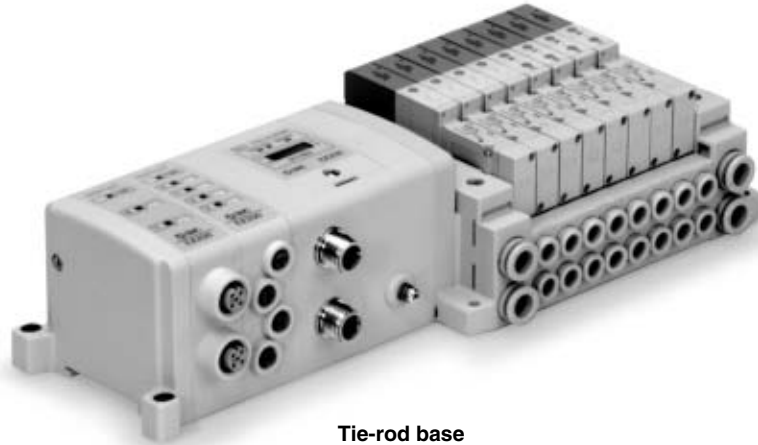

Tie-rod base

Applicable series	Tie-rod base manifold SV1000/SV2000/SV3000
	• Number of inputs/outputs: 32 each

SV

SZ

SY

SYJ

SX

Series EX250

Serial Wiring with Input/Output Unit

Series SV

How to Order

● Tie-rod base

SS5V 1 — **W10S1** **QW** [] [] [] **D** — **05** **U** [] [] []

Series

1	SV1000
2	SV2000
3	SV3000

Enclosure
IP67 specifications

SI unit

QW	For DeviceNet
0	Without SI unit

- Input blocks cannot be mounted without SI unit.
- When the DIN rail is included without an SI unit, the DIN rail length will accommodate an SI unit and one input block.

Input block stations

Nil	None
1	1 station
⋮	⋮
8	8 stations

Note) Without SI unit, the symbol is nil.

Input block type

Nil	Without input block
1	M12: 2 inputs
2	M12: 4 inputs
3	M8: 4 inputs (3 pins)

Note) Without SI unit, the symbol is nil.

Input block common specifications

Nil	+COM
N	-COM

● Valve stations

Symbol	Stations	Note
02	2 stations	Double wiring specifications (1)
⋮	⋮	
16	16 stations	
02	2 stations	Specified layout (2) (up to 32 solenoids possible.)
⋮	⋮	
20	20 stations	

Note 1) Double wiring specifications: Single, double, 3 position and 4 position solenoid valves can be used on all manifold stations. Use of a single solenoid will result in an unused control signal. If this is not desired, order with a specified layout.

Note 2) Specified layout: Indicate wiring specifications on the manifold specification sheet. (Note that double and 3 position valves cannot be used where single solenoid wiring has been specified.)

● P, E port location

U	U side (2 to 10 stations)
D	D side (2 to 10 stations)
B	Both sides (2 to 20 stations)

● SUP/EXH block assembly specifications

Nil	Internal pilot
S*	Internal pilot/Built-in silencer
R	External pilot
RS*	External pilot/Built-in silencer

Note) When the built-in silencer type is used, keep the exhaust port from coming in direct contact with water or other liquids.

● Mounting

Nil	Direct mounting
D	DIN rail mounting (With DIN rail)
D0*	DIN rail mounting (Without DIN rail)
D3	For 3 stations
⋮	⋮
D20	For 20 stations

* In the case of D0, only DIN rail fittings are attached.

● A, B port size (metric)

Symbol	A, B port	P, E port	Applicable series
C3	One-touch fitting for ø3.2	One-touch fitting for ø8	SV1000
C4	One-touch fitting for ø4		
C6	One-touch fitting for ø6		
C4	One-touch fitting for ø4	One-touch fitting for ø10	SV2000
C6	One-touch fitting for ø6		
C8	One-touch fitting for ø8		
C6	One-touch fitting for ø6	One-touch fitting for ø12	SV3000
C8	One-touch fitting for ø8		
C10	One-touch fitting for ø10		
M	A, B ports mixed		

● A, B port size (inch)

Symbol	A, B port	P, E port	Applicable series
N1	One-touch fitting for ø1/8"	One-touch fitting for ø5/16"	SV1000
N3	One-touch fitting for ø5/32"		
N7	One-touch fitting for ø1/4"		
N3	One-touch fitting for ø5/32"	One-touch fitting for ø3/8"	SV2000
N7	One-touch fitting for ø1/4"		
N9	One-touch fitting for ø5/16"		
N7	One-touch fitting for ø1/4"	One-touch fitting for ø3/8"	SV3000
N9	One-touch fitting for ø5/16"		
N11	One-touch fitting for ø3/8"		
M	A, B ports mixed		

* In the case of mixed specifications (M), indicate separately on the manifold specification sheet.

* Port sizes of X, PE port for external pilot specifications (R, RS) are ø4 (metric), ø5/32" (inch) for SV1000/2000 and ø6 (metric) and ø1/4" (inch) for SV3000/4000.

Valve Manifold Common Specifications Series SV

Cassette base manifold

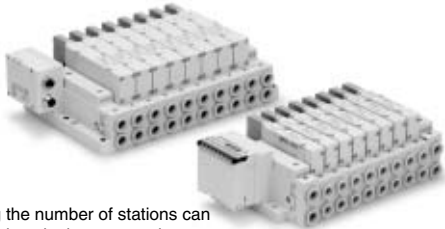

- Changing the number of stations can be easily done by lever operation.

Manifold Specifications

Applicable series		SV1000	SV2000
Manifold type		Stacking type cassette base manifold	
1 (P: SUP)/3, 5 (E: EXH) type		Common SUP, EXH	
Valve stations (maximum)		18 stations	20 stations
Max. number of solenoids		18 points	26 points
Port size	1(P), 3/5(E) port	C8, N9	C10, N11
	4(A), 2(B) port	C3, C4, C6 N1, N3, N7	C4, C6, C8 N3, N7, N9

Flow Characteristics

Model	Port size		Flow characteristics					
	1, 5, 3 (P, EA, EB)	4, 2 (A, B)	1 → 4/2 (P → A/B)			4/2 → 3/5 (A/B → E)		
			C [dm ³ /(s·bar)]	b	Cv	C [dm ³ /(s·bar)]	b	Cv
SS5V1-16	C8	C6	0.89	0.22	0.22	0.98	0.21	0.23
SS5V2-16	C10	C8	2.3	0.28	0.50	2.7	0.18	0.56

Note) The value is for manifold base with 5 stations and individually operated 2 position type.

Tie-rod base manifold

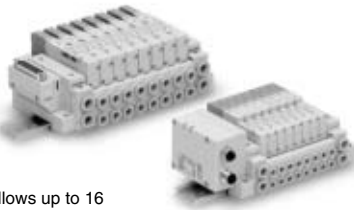

- 34 pins connector allows up to 16 stations with double solenoids.

Manifold Specifications

Applicable series		SV1000	SV2000	SV3000	SV4000
Manifold type		Tie-rod base manifold			
1 (P: SUP)/3, 5 (E: EXH) type		Common SUP, EXH			
Valve stations (maximum)		20 stations			
Max. number of solenoids		32 points			
Port size	1(P), 3/5(E) port	C8, N9	C10, N11	C12, N11	C12, N11, 03
	4(A), 2(B) port	C3, C4, C6 N1, N3, N7	C4, C6, C8 N3, N7, N9	C6, C8, C10 N7, N9, N11	C8, C10, C12 N9, N11, 02, 03

Flow Characteristics

Model	Port size		Flow characteristics					
	1, 5, 3 (P, EA, EB)	4, 2 (A, B)	1 → 4/2(P → A/B)			4/2 → 3/5(A/B → E)		
			C [dm ³ /(s·bar)]	b	Cv	C [dm ³ /(s·bar)]	b	Cv
SS5V1-10	C8	C6	0.98	0.26	0.24	1.1	0.35	0.28
SS5V2-10	C10	C8	2.1	0.20	0.46	2.4	0.18	0.48
SS5V3-10	C12	C10	4.2	0.22	0.91	4.3	0.21	0.93
SS5V4-10	C12	C12	6.2	0.19	1.3	7.0	0.18	1.6

Note) The value is for manifold base with 5 stations and individually operated 2 position type.

Enclosure of Manifold Variations (Common for cassette base and tie-rod base)

Series	Enclosure (Based on IEC529)
Series EX500 Decentralized serial wiring	IP67 *
Series EX250 Serial wiring with input/output onit	IP67
Series EX120 Dedicated output serial wiring	Dusttight (IP40)
For circular connector	IP67
D-sub connector	Dusttight (IP40)
Flat ribbon cable	Dusttight (IP40)

* Enclosure of a gateway unit and input manifold is IP65.

How to Order Valve Manifold Assembly

Ordering example (SV1000)

Manifold

SS5V1-W10S1QW11ND-05B-C6 (1 set)

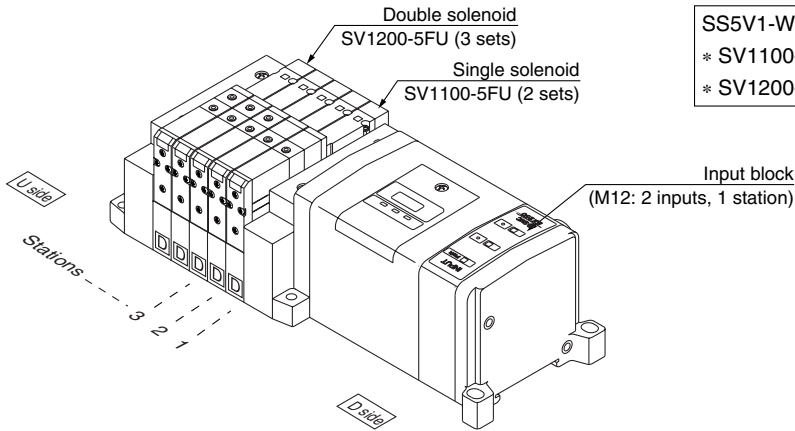

SS5V1-W10S1QW11ND-05B-C6....1 set (manifold part no.)
 * SV1100-5FU.....2 sets (Single solenoid part no.)
 * SV1200-5FU.....3 sets (Double solenoid part no.)

SV

SZ

SY

SYJ

SX

How to Order Solenoid Valves

SV 1 1 00 [] [] — **5 F** [] [] []

Note)



Note) Available with manifold block for station additions. Refer to page 1-2-93.

Series

1	SV1000
2	SV2000
3	SV3000

Type of actuation

1	2 position single solenoid
2	2 position double solenoid
3	3 position closed center
4	3 position exhaust center
5	3 position pressure center
A	4 position dual 3 port valve: N.C./N.C.
B	4 position dual 3 port valve: N.O./N.O.
C	4 position dual 3 port valve: N.C./N.O.

* 4 position dual 3 port valves are applicable to Series SV1000 and SV2000 only.

Pilot type

Nil	Internal pilot
R	External pilot

* External pilot specifications is not available for 4 position dual 3 port valves.

Back pressure check valve

Nil	None
K	Built-in

* Built-in back pressure check valve type is applicable to series SV1000 only.

* Back pressure check valve is not available for 3 position closed center and 3 position pressure center.



Refer to Precautions 2 on page 1-2-9.

Manual override

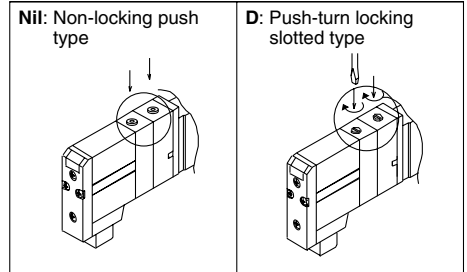

Light/Surge voltage suppressor

U	With light/surge voltage suppressor
R	With surge voltage suppressor

Rated voltage

5	24 VDC
---	--------

Applicable network: DeviceNet

The serial transmission system reduces wiring work, while minimizing wiring and saving space.

DeviceNet compatible SI unit

As a DeviceNet slave unit, it is capable of solenoid valve ON/OFF control up to a maximum of 32 points. In addition, by connecting an input block a maximum of 32 sensor signal inputs are possible.

Input block

This is an expansion block which connects to an SI unit to perform sensor input from auto switches, etc. Two or four sensor inputs can be accommodated by one input block, and the common can be matched to the sensor by an NPN/PNP switch.^{Note)} Input connectors are available in both M8 and M12 types.

Note) COM is set at the shipment. Please contact SMC for alteration after shipment.

Details in connector

Input connector: M12 5 pins (socket)
Cable side connector example:
OMRON Corporation: XS2G 2 input block (EX250-IE1)

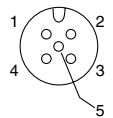

No.	Description	Function
1	SW+	Sensor power supply +
2	N.C (SIGNAL)	Open*
3	SW-	Sensor power supply -
4	SIGNAL	Sensor input signal
5	E	Sensor ground

* In the case of a 4 input block (EX250-IE2), this is the sensor input signal.

Communication connector: M12 ... 5 pins (socket)
Example of corresponding cable assemblies with connector:
OMRON Corporation: DCA1-5CN05F1
Karl Lumberg GmbH & Co. KG: RKT5-56

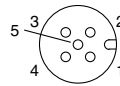

No.	Description	Function
1	Drain	Drain/Shield
2	V+	Circuit power supply +
3	V-	Circuit power supply -
4	CAN_H	Signal H
5	CAN_L	Signal L

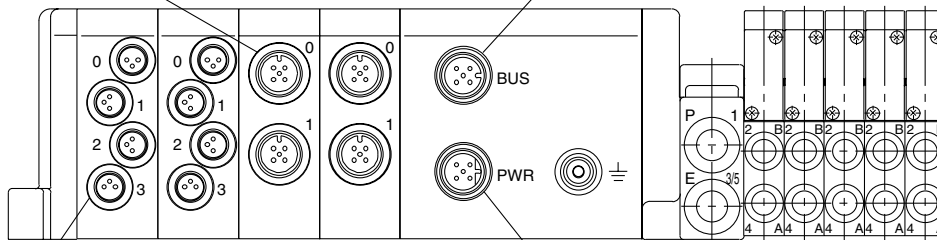

Input connector: M8 3 pins (socket)
Cable side connector example:
Franz Binder GmbH: 718, 768 series



No.	Description	Function
1	24V	Sensor power supply +
3	0V	Sensor power supply -
4	IN	Sensor input signal

Power connector: M12 ... 5 pins (plug) (boss configuration differs from communication connector)
Example of corresponding cable assemblies with connector:
Hans Turck FmbH & Co. KG: WAKW4. 5T-2

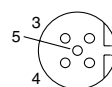

No.	Description	Function
1	SV24V	For solenoid valve +24 V
2	SV0V	For solenoid valve 0 V
3	SW24V	For input block +24 V
4	SW0V	For input block 0 V
5	E	Ground

Indicator unit (LED) descriptions and functions

SI unit

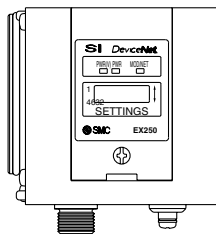

Description	Function
PWR(V)	ON when solenoid valve power supply is turned ON
PWR	ON when DeviceNet circuit power supply input is turned ON
MOD/NET	OFF: Power supply off, on line, or when checking duplication of MAC_ID
	Green blinking: Waiting for connection (On line)
	Green ON: Connection established (On line)
	Red blinking: Connection time out (Minor communication abnormality occurs)
	Red ON: MAC_ID duplication error, or BUSOFF error (Major communication abnormality occurs)

Input block

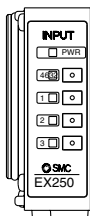

Description	Function
PWR	ON when sensor power is turned ON
0 to 3	ON when each sensor input goes ON

Weight

Description	weight (g)
SI unit	225
Input block	85
End plate assembly	30

* For parts composition, refer to page 1-2-90.

Dimensions: Series SV1000 for EX250 Serial Wiring with Input/Output Unit

● Tie-rod base manifold: SS5V1-W10S1□□□□□D- Stations $\frac{U}{D}$ (S, R, RS) - C3, N1
C4, N3 (-D)
C6, N7

- When P, E port outlets are indicated on the U side or D side, the P, E ports on the opposite side are plugged.
- External pilot port positions and silencer discharge port positions are the same as P, E port outlet positions.

(With 2 input blocks)

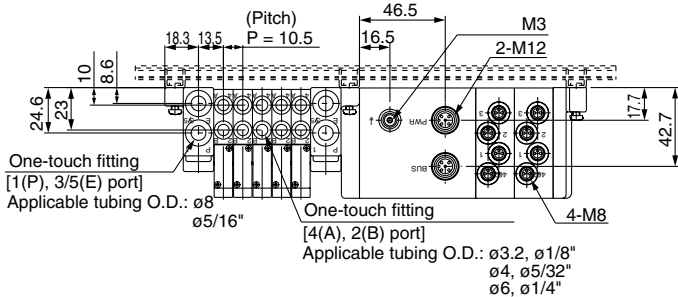

With External Pilot Specifications

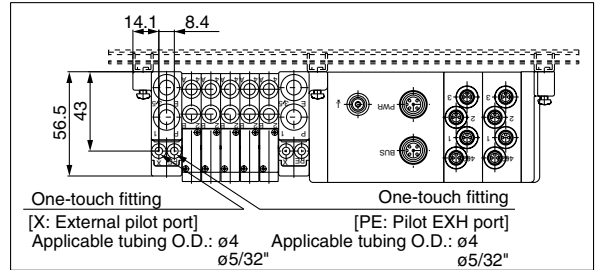

SV

SZ

SY

SYJ

SX

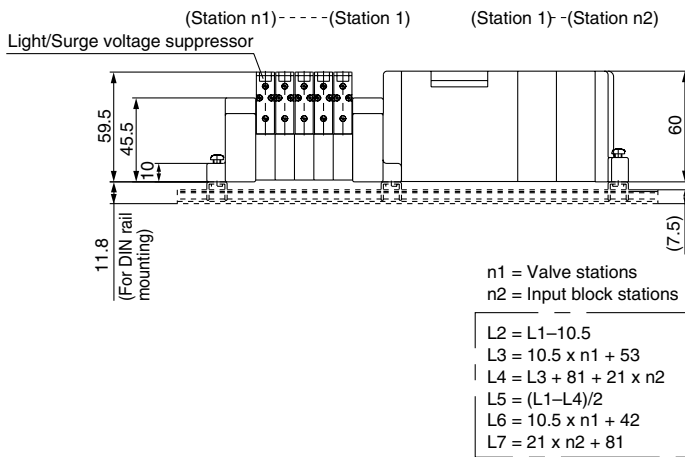
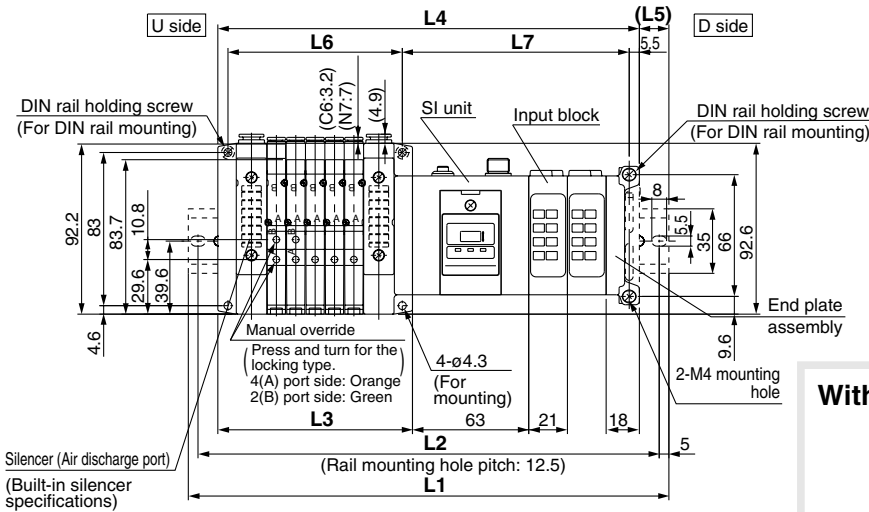

With option

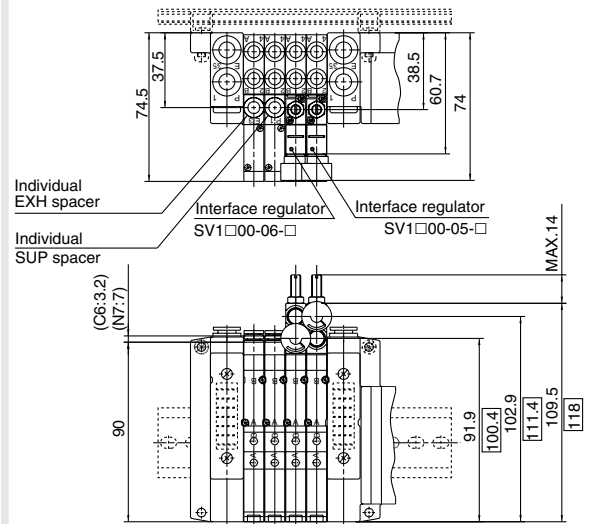

Dimensions are the ones for SV1300-□□-□.

L1: DIN Rail Overall Length

Valve stations Input block Stations (n2)	2	3	4	5	6	7	8	9	10	11	12	13	14	15	16	17	18	19	20
0	185.5	198	210.5	210.5	223	235.5	248	260.5	273	273	285.5	298	310.5	323	335.5	348	348	360.5	373
1	210.5	210.5	223	235.5	248	260.5	273	273	285.5	298	310.5	323	335.5	348	348	360.5	373	385.5	398
2	223	235.5	248	260.5	273	273	285.5	298	310.5	323	335.5	348	348	360.5	373	385.5	398	410.5	410.5
3	248	260.5	273	273	285.5	298	310.5	323	335.5	348	348	360.5	373	385.5	398	410.5	410.5	423	435.5
4	273	273	285.5	298	310.5	323	335.5	348	348	360.5	373	385.5	398	410.5	410.5	423	435.5	448	460.5
5	285.5	298	310.5	323	335.5	348	348	360.5	373	385.5	398	410.5	410.5	423	435.5	448	460.5	473	473
6	310.5	323	335.5	348	348	360.5	373	385.5	398	410.5	410.5	423	435.5	448	460.5	473	473	485.5	498
7	335.5	348	348	360.5	373	385.5	398	410.5	410.5	423	435.5	448	460.5	473	473	485.5	498	510.5	523
8	348	360.5	373	385.5	398	410.5	410.5	423	435.5	448	460.5	473	473	485.5	498	510.5	523	535.5	535.5

(mm)

Series SV

Dimensions: Series SV2000 for EX250 Serial Wiring with Input/Output Unit

● Tie-rod base manifold: SS5V2-W10S1 □ □ □ □ D- Stations $\frac{U}{D}$ (S, R, RS)- $\frac{C4, N3}{C6, N7}$ (-D) C8, N9

(With 2 input blocks)

- When P, E port outlets are indicated on the U side or D side, the P, E ports on the opposite side are plugged.
- External pilot port positions and silencer discharge port positions are the same as P, E port outlet positions.

With External Pilot Specifications

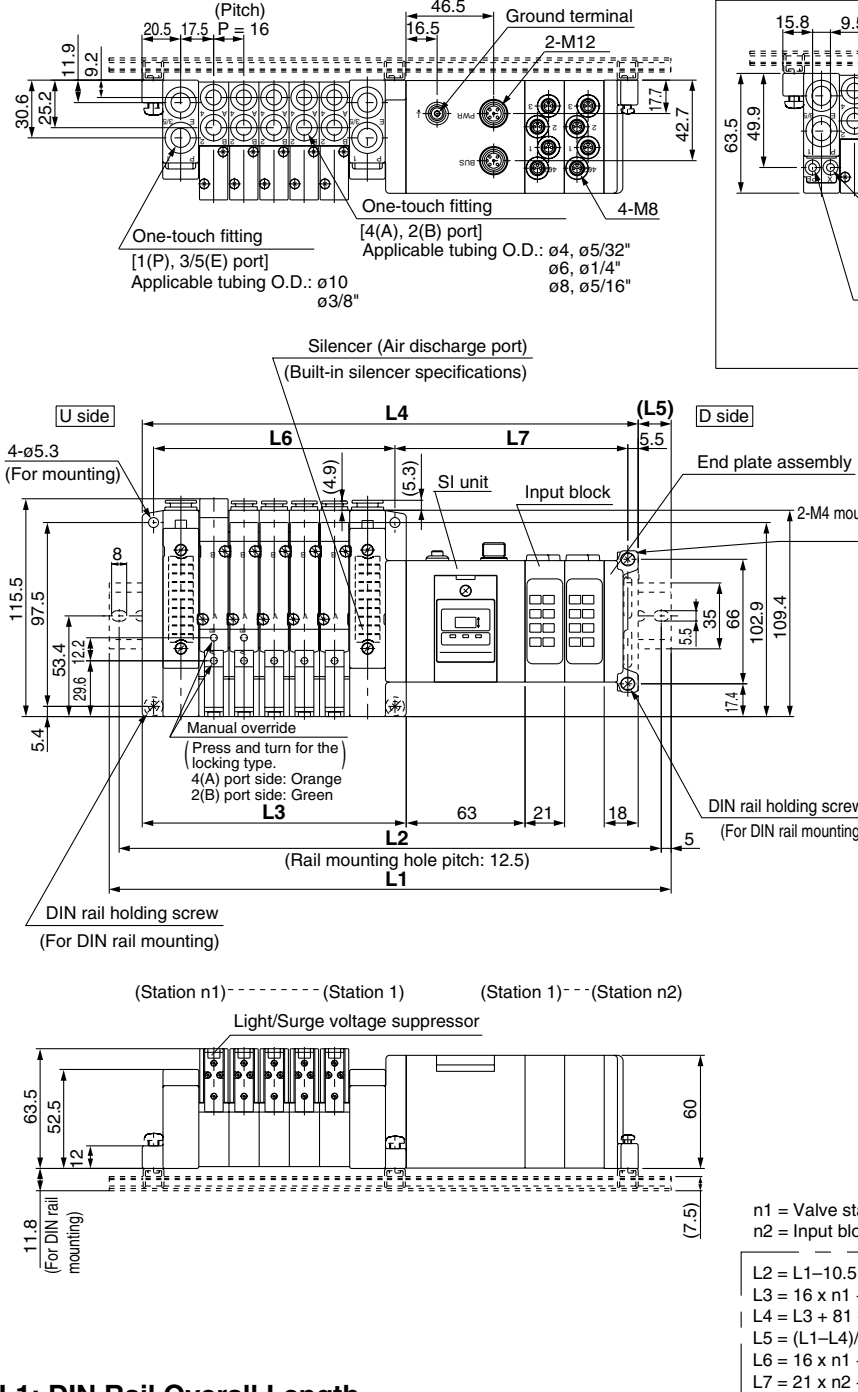
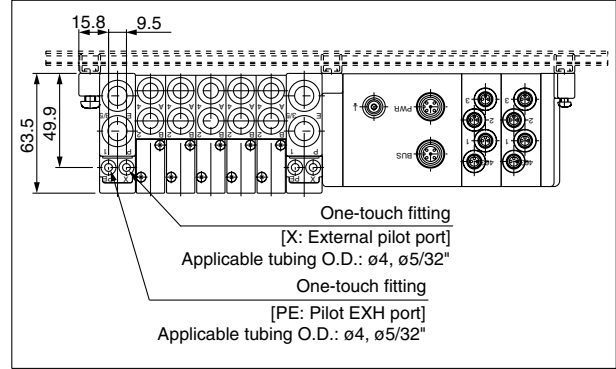

With option

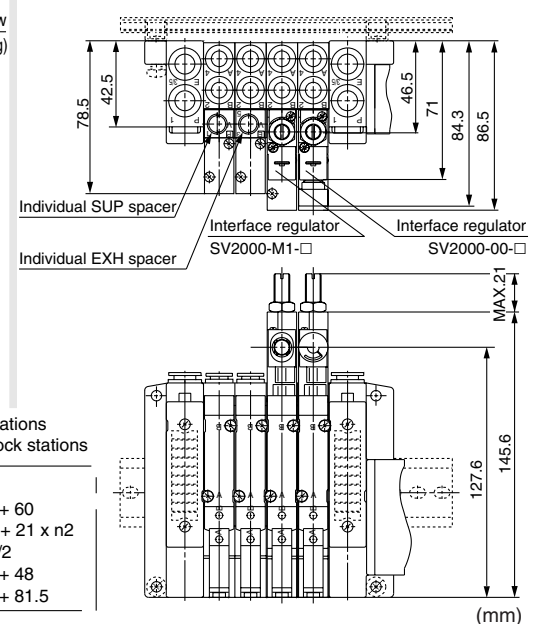

- n1 = Valve stations
- n2 = Input block stations
- L2 = L1 - 10.5
- L3 = 16 x n1 + 60
- L4 = L3 + 81 + 21 x n2
- L5 = (L1 - L4) / 2
- L6 = 16 x n1 + 48
- L7 = 21 x n2 + 81.5

L1: DIN Rail Overall Length

Valve stations (n1) Input block Stations (n2)	2	3	4	5	6	7	8	9	10	11	12	13	14	15	16	17	18	19	20
0	198	223	235.5	248	260.5	285.5	298	310.5	335.5	348	360.5	373	398	410.5	423	448	460.5	473	485.5
1	223	235.5	260.5	273	285.5	298	323	335.5	348	373	385.5	398	410.5	435.5	448	460.5	485.5	498	510.5
2	248	260.5	273	298	310.5	323	335.5	360.5	373	385.5	410.5	423	435.5	448	473	485.5	498	510.5	535.5
3	260.5	285.5	298	310.5	335.5	348	360.5	373	398	410.5	423	435.5	460.5	473	485.5	510.5	523	535.5	548
4	285.5	298	323	335.5	348	360.5	385.5	398	410.5	435.5	448	460.5	473	498	510.5	523	548	560.5	573
5	310.5	323	335.5	360.5	373	385.5	398	423	435.5	448	473	485.5	498	510.5	535.5	548	560.5	585.5	598
6	323	348	360.5	373	398	410.5	423	435.5	460.5	473	485.5	510.5	523	535.5	548	573	585.5	598	610.5
7	348	360.5	385.5	398	410.5	435.5	448	460.5	473	498	510.5	523	535.5	560.5	573	585.5	610.5	623	635.5
8	373	385.5	398	423	435.5	448	460.5	485.5	498	510.5	535.5	548	560.5	573	598	610.5	623	648	660.5

Dimensions: Series SV3000 for EX250 Serial Wiring with Input/Output Unit

● Tie-rod base manifold: SS5V3-W10S1□□□□D- **Stations** $\begin{matrix} U \\ D \end{matrix}$ (S, R, RS)- $\begin{matrix} C6, N7 \\ C8, N9 \\ C10, N11 \end{matrix}$ (-D)

(With 2 input blocks)

- When P, E port outlets are indicated on the U side or D side, the P, E ports on the opposite side are plugged.
- External pilot port positions and silencer discharge port positions are the same as P, E port outlet positions.

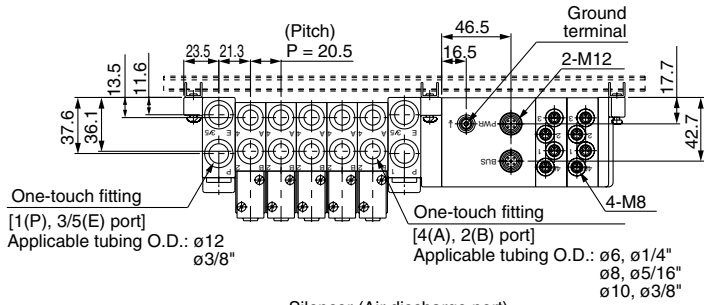

With External Pilot Specifications

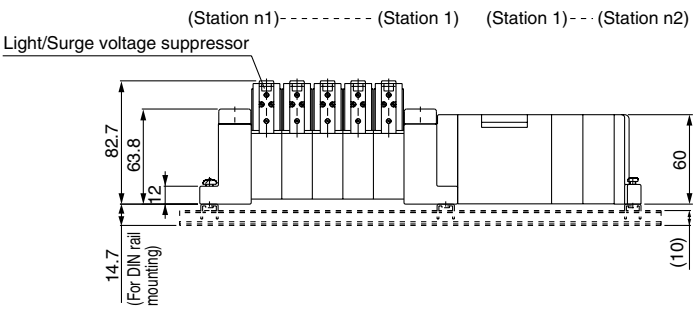
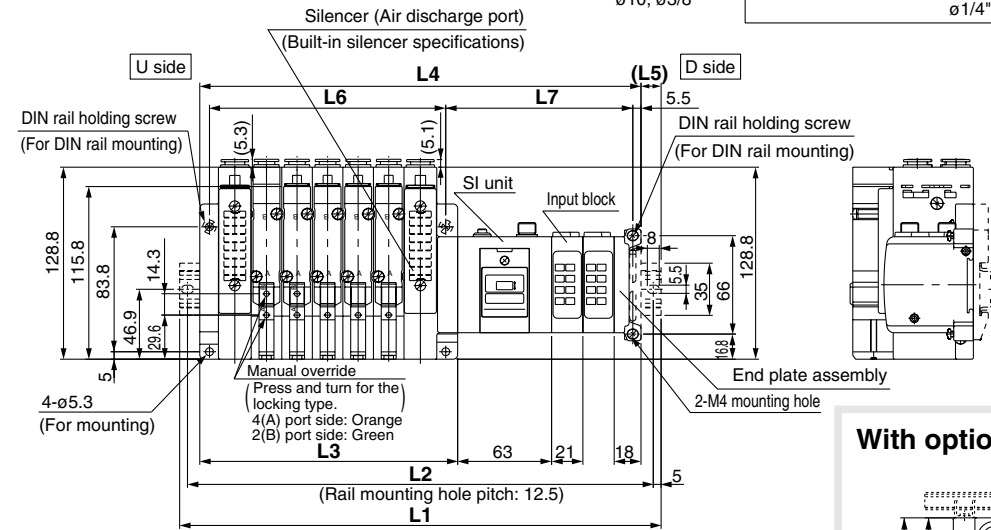
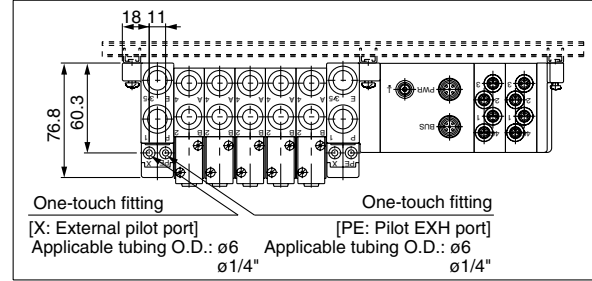

- n1 = Valve stations
n2 = Input block stations
- L2 = L1 - 10.5
L3 = 20.5 x n1 + 70.5
L4 = L3 + 81 + 21 x n2
L5 = (L1 - L4) / 2
L6 = 20.5 x n1 + 56
L7 = 21 x n2 + 83.5

With option

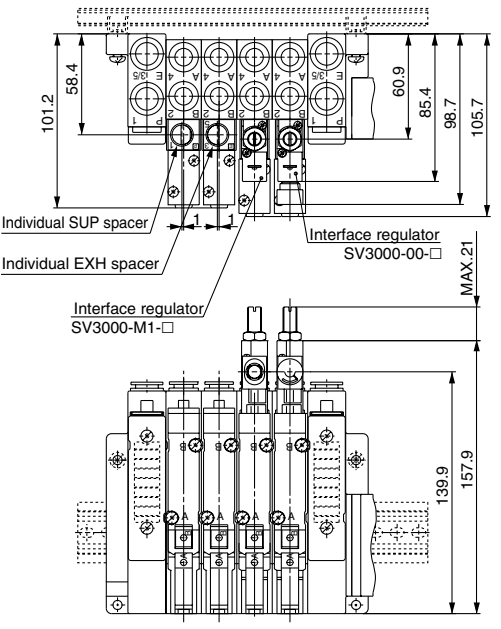

L1: DIN Rail Overall Length

Valve stations (n1) Input block Stations (n2)	2	3	4	5	6	7	8	9	10	11	12	13	14	15	16	17	18	19	20
0	223	248	260.5	285.5	298	323	348	360.5	385.5	410.5	423	448	473	485.5	510.5	535.5	548	573	585.5
1	248	260.5	285.5	310.5	323	348	360.5	385.5	410.5	423	448	473	485.5	510.5	535.5	548	573	585.5	610.5
2	260.5	285.5	310.5	323	348	360.5	385.5	410.5	423	448	473	485.5	510.5	535.5	548	573	598	610.5	635.5
3	285.5	310.5	323	348	373	385.5	410.5	423	448	473	485.5	510.5	535.5	548	573	598	610.5	635.5	648
4	310.5	323	348	373	385.5	410.5	423	448	473	485.5	510.5	535.5	548	573	598	610.5	635.5	660.5	673
5	323	348	373	385.5	410.5	435.5	448	473	485.5	510.5	535.5	548	573	598	610.5	635.5	660.5	673	698
6	348	373	385.5	410.5	435.5	448	473	485.5	510.5	535.5	548	573	598	610.5	635.5	660.5	673	698	723
7	373	385.5	410.5	435.5	448	473	498	510.5	535.5	548	573	598	610.5	635.5	660.5	673	698	723	735.5
8	385.5	410.5	435.5	448	473	498	510.5	535.5	548	573	598	610.5	635.5	660.5	673	698	723	735.5	760.5

(mm)

- SV
- SZ
- SY
- SYJ
- SX