

Direct Operated 2 Port Solenoid Valve For Oil

Series VCL

How to Order Valves (Single Unit)

VC L 2 1 1 G 2 02

For oil

When no symbol is shown for "Material and insulation type"

- Body material: C37
- Seal material: FKM
- Coil insulation: Class B

Series

2	Class 2
3	Class 3
4	Class 4

Valve type

Voltage

1	100 VAC
2	200 VAC
3	110 VAC
4	220 VAC
5	24 VDC
6	12 VDC
36	230 VAC

* Class B in AC has a rectifying circuit built-in.
** Class H is AC only. No rectifying circuit.
*** Please consult with SMC regarding other voltages.

Option

Nil	None
F	Foot type bracket

Material and insulation type

Symbol	Body material	Seal material	Coil insulation type
Nil	C37	FKM	Class B
D			Class H
H	SUS		Class B
N			Class H

Thread type

Nil	Rc
N	NPT
F	G

Port size

Symbol	Port size	Class 2	Class 3	Class 4
01	1/8 (6A)	○	—	—
02	1/4 (8A)	○	○	○
03	3/8 (10A)	—	○	○
04	1/2 (15A)	—	○	○
06	3/4 (20A)	—	—	○

Electrical entry

G – Grommet	C – Conduit
T – Conduit terminal TL – Conduit terminal with indicator light (Note 1)	D – DIN terminal DL – DIN terminal with light DO – DIN terminal (without connector)

Connector

* All class B coils come with surge voltage suppressor.
** Available types of electrical entry for type H coil are either G, C and T.
(Surge voltage suppressor is not equipped.)
Note 1) TL is available only for standard specifications valve.

Orifice size

Symbol	Orifice size (mmø)	Class 2	Class 3	Class 4
2	2	○	—	—
3	3	○	○	○
4	4	○	○	○
5	5	○	○	○
7	7	—	○	○
10	10	—	○	○

* Refer to the below table for orifice and port size combinations.

Orifice and Port Size Combinations

Class	Port size	Orifice size (mmø)					
		2	3	4	5	7	10
2	1/8 (6A)	●	●	●	●	—	—
	1/4 (8A)	●	●	●	●	—	—
3	1/4 (8A)	—	●	●	●	●	—
	3/8 (10A)	—	●	●	●	●	●
4	1/2 (15A)	—	—	—	—	—	●
	1/4 (8A)	—	●	●	●	●	—
	3/8 (10A)	—	●	●	●	●	●
	1/2 (15A)	—	—	—	—	—	●
	3/4 (20A)	—	—	—	—	—	●

Direct Operated 2 Port Solenoid Valve For Oil Series VCL

Specifications



		Standard specifications	High temperature specifications		
Valve specifications	Valve construction	Direct operated poppet			
	Fluid	Oil [50 mm ² /s] or less			
	Withstand pressure (MPa)	5.0			
	Body material	C37, Stainless steel			
	Seal material	FKM			
	Ambient temperature (°C) ⁽¹⁾	-20 to 60	-20 to 100		
	Fluid temperature (°C) ⁽¹⁾	-10 to 60 (No freezing)	-10 to 100		
	Enclosure	Dusttight, Low jetproof (equivalent to IP65)			
	Environment	Location without corrosive or explosive gases			
	Valve leakage (cm ³ /min)	0 (with oil pressure)			
	Mounting orientation	Unrestricted			
	Vibration/Impact resistance (m/s ²) ⁽³⁾	30/150 or less			
Coil specifications	Rated voltage	24, 12 VDC, 100, 110, 200, 220, 230 VAC (50/60 Hz)	100, 200, 220, 230 VAC (50/60 Hz)		
	Allowable voltage fluctuation	±10% of rated voltage			
	Coil insulation type	Class B		Class H	
	Power consumption	DC	VCL20: 6 W, VCL30: 8 W, VCL40: 11.5 W		
	Apparent power	AC ^{50/60} Hz	VCL20: 8.5 VA VCL30: 10 VA VCL40: 13 VA	Inrush	VCL20: 22/19 VA VCL30: 36/30 VA VCL40: 45/37 VA
				Holding	VCL20: 10/8 VA VCL30: 15/13 VA VCL40: 19/16 VA



Note 1) When the ambient temperature or fluid temperature is 60°C or more, use high temperature specifications (class H coil).

Note 2) Since a rectifier circuit is used for class B coils with AC, there is no difference in apparent power between inrush and holding.

Note 3) Vibration resistance Conditions when tested with one sweep 10 to 250 Hz in the axial direction and at a right angle to the armature, in both energized and deenergized states No malfunction occurred when tested. (Value at the initial state)

Impact resistance Conditions when tested with a drop tester in the axial direction and at a right angle to the armature, one time each in energized and deenergized states. No malfunction occurred when tested. (Value at the initial state)

Characteristic Specifications

Model	Class	Port size ⁽¹⁾	Orifice size (mmø) ⁽¹⁾	N.C. Max. operating pressure differential (MPa)	Flow characteristics		Max. system pressure (MPa)	Weight (kg) ⁽²⁾
					Av x 10 ⁻⁶ (m ²)	Cv converted		
VCL2	2	1/8 (6A) 1/4 (8A)	2	1.5	3.8	0.16	2.0	1/8 : 0.21 1/4 : 0.24
			3	0.8	7.9	0.33		
			4	0.4	12	0.51		
			5	0.25	16	0.65		
VCL3	3	1/4 (8A) 3/8 (10A) 1/2 (15A)	3	1.5	8.4	0.35	2.0	1/4 : 0.42 3/8 : 0.40 1/2 : 0.49
			4	0.8	13	0.54		
			5	0.5	19	0.80		
			7	0.2	33	1.4		
VCL4	4	1/4 (8A) 3/8 (10A) 1/2 (15A) 3/4 (20A)	3	2.0	8.4	0.35	2.0	1/4 : 0.58 3/8 : 0.55 1/2 : 0.62 3/4 : 0.78
			4	1.1	14	0.60		
			5	0.7	20	0.85		
			7	0.3	33	1.4		
			10	0.12	50	2.1		



Note 1) Refer to page 17-2-32 in model selection regarding port size and orifice size combinations.
Note 2) The weight is the value for the grommet type.

- VC□
- VDW
- VQ
- VX2
- VX□
- VX3
- VXA
- VN□
- LVC
- LVA
- LVH
- LVD
- LVQ
- LQ
- LVN
- T/
TIL
- PA
- PAX
- PB

Series VCL

Construction

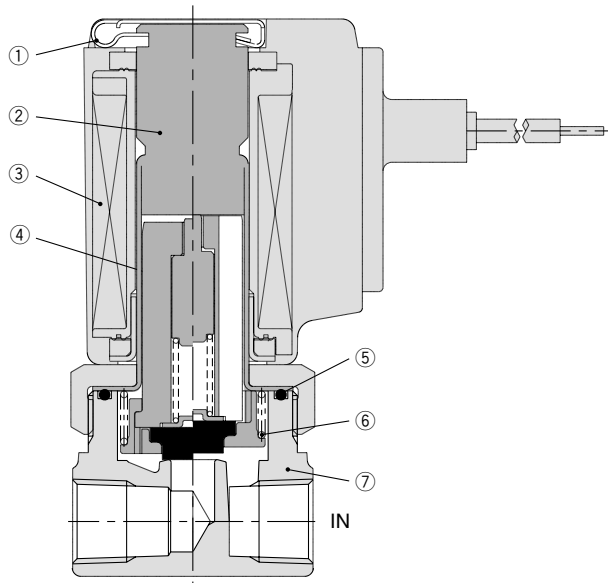

Component Parts

No.	Description	Material	
		Standard	Option
①	Clip	Stainless steel	—
②	Tube assembly	Stainless steel	Stainless steel, Cu (for class H coil)
③	Coil assembly	Class B	Class H
④	Armature assembly	Stainless steel, FKM	—
⑤	O-ring	FKM	—
⑥	Return spring	Stainless steel	—
⑦	Body	C37	Stainless steel

Dimensions: Bracket

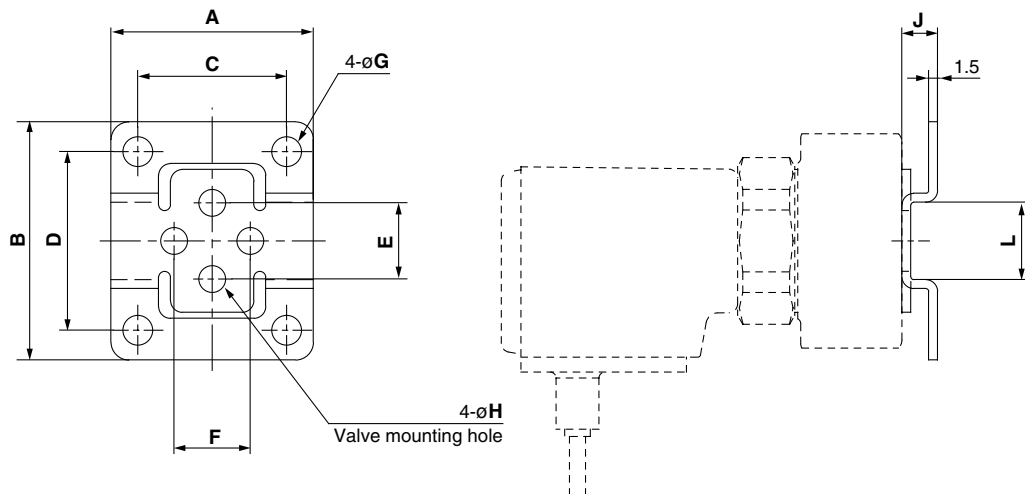

Bracket Mounting Dimensions/Bracket Material: Stainless Steel

Valve model	Port size	Bracket part no.	A	B	C	D	E	F	G	H	J	L
VCL2□	1/8, 1/4	VCW20-12-01A	34	40	25	30	12.8	12.8	5	4.5	6	13
VCL3□	1/4, 3/8	VCW30-12-02A	42	52	30	40	19	19	6	5.5	7	19
	1/2	VCW30-12-04A ^{Note 1)}	48	56	36	44	23	23	6	5.5	7	23
VCL4□	1/4, 3/8	VCW40-12-02A	42	52	30	40	23	23	6	5.5	7	19
	1/2	VCW30-12-04A ^{Note 1)}	48	56	36	44	23	23	6	5.5	7	23
	3/4	VCW40-12-06A	56	65	44	53	28.2	28.2	6	5.5	7	26

* 2 Mounting screws (for mounting bracket) are included in bracket part no.

Note 1) The same bracket is used for VCL3□ and VCL4□ (port size 1/2).

Dimensions (N.C.)

Grommet: G

Conduit: C

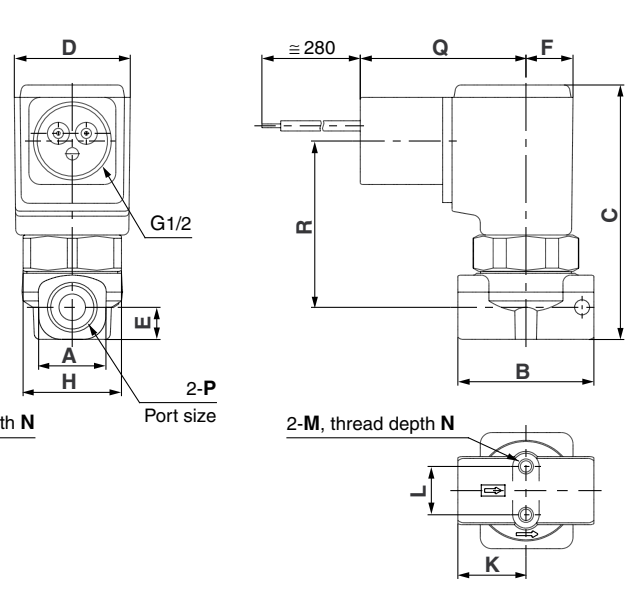
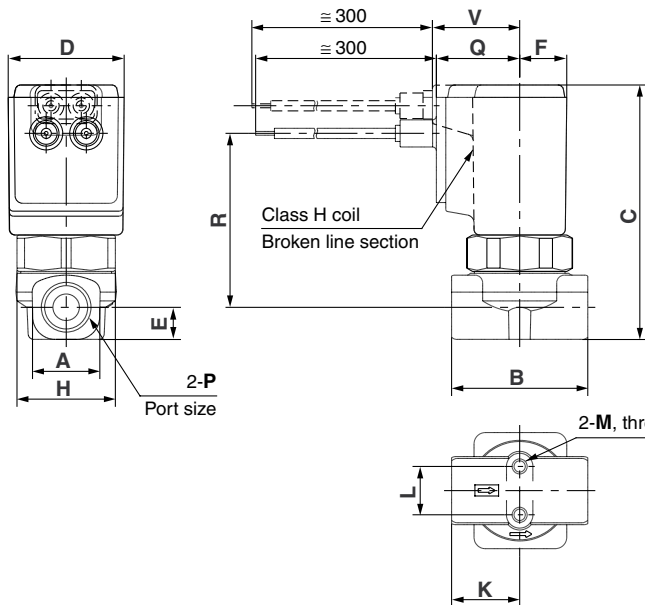

DIN terminal: D

Conduit terminal: T

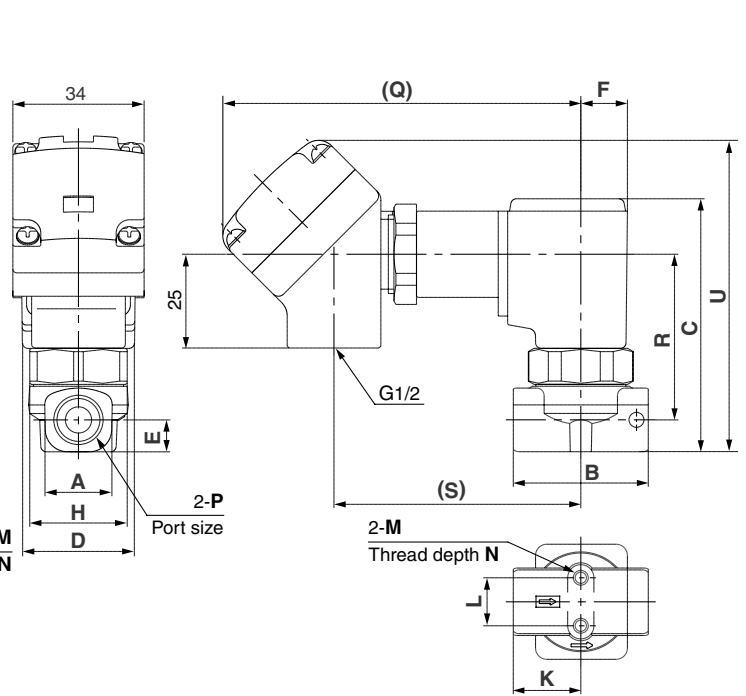
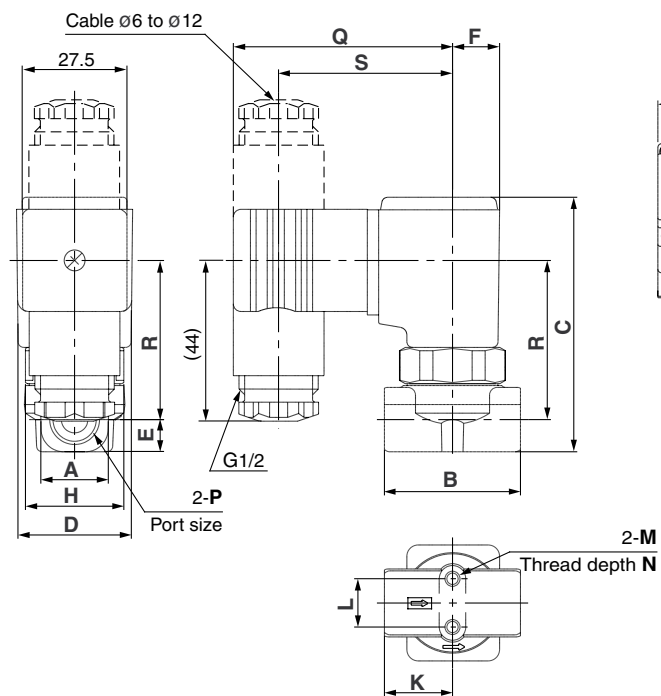

- VC□
- VDW
- VQ
- VX2
- VX□
- VX3
- VXA
- VN□
- LVC
- LVA
- LVH
- LVD
- LVQ
- LQ
- LVN
- T/
TIL
- PA
- PAX
- PB

N.C. Dimensions

(mm)

Model	P Port size	A	B	C	D	E	F	H	K	L	M	N	Grommet: G			Conduit: C		DIN terminal: D			Conduit terminal: T			
													Q	V	R	Q	R	Q	R	S	Q	R	S	U
VCL21	1/8	13.5	28	64	31	6.5	12.5	28	14	12.8	M4	4.5	22	23	45	44	43	58	40.5	46.5	99	43	66	83
	1/4	18	36	67.5	31	8.5	12.5	28	18	12.8	M4	6	22	23	46	44	44	58	41.5	46.5	99	44	66	86
VCL31	1/4, 3/8	22	40	81.5	36.5	11	15	32	20	19	M5	8	24	25	56.5	46	54.5	60	52	48.5	101	54.5	68	99
	1/2	30	50	86	36.5	13.5	15	32	25	23	M5	8	24	25	59	46	57	60	54.5	48.5	101	57	68	104
VCL41	1/4, 3/8	22	45	90	41	11	17	36	22.5	23	M5	8	26	26.5	64.5	48	62.5	62	60	50.5	103	62.5	70	107
	1/2	30	50	94	41	13.5	17	36	25	23	M5	8	26	26.5	66.5	48	64.5	62	62	50.5	103	64.5	70	111.5
	3/4	35	60	102	41	17.5	17	36	30	28.2	M5	8	26	26.5	70	48	68	62	65.5	50.5	103	68	70	119

Note) For class H

Series VCL

How to Order Manifold

VV2C L 2 02 01

For oil
In the case of no symbol for material
• Base material: C37
• Seal material: FKM (4 stations or more)

Series

2	Class 2
3	Class 3
4	Class 4

Material

Symbol	Base material	Seal material
Nil	C37	FKM
H	Stainless steel	

Thread type

Symbol	Thread type
Nil	Rc
N	NPT
F	G

OUT port size

Symbol	Port size
01	1/8 (6A)
02	1/4 (8A)

* All IN ports are 3/8.

Stations

02	2 stations
...	...
10	10 stations

* Refer to page 17-2-37 in the L dimension table regarding the maximum number of stations.



How to Order Manifold Assembly

Enter the mounting valve and option part numbers under the manifold base part number.

<Ordering Example>

VV2CL2-0501 1 set Manifold part no.
* VCL23-5G-2 5 sets Valve part no. (Stations 1 to 5)

"*" is the symbol for assembly. Add an "*" in front of the part numbers for solenoid valves, etc., to be mounted.

Enter together in order, counting from station 1 on the D side.

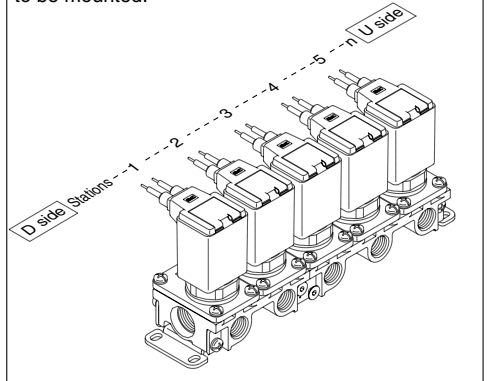

How to Order Valves (For manifold)

VC L 2 3 1 G 2

For oil
When there is no symbol for oil material and insulation type
• Body material: C37
• Seal material: FKM
• Coil insulation: Class B

Series

2	Class 2
3	Class 3
4	Class 4

Valve type

3	N.C. for manifold
---	-------------------

Voltage

1	100 VAC
2	200 VAC
3	110 VAC
4	220 VAC
5	24 VDC
6	12 VDC
36	230 VAC

* Class B in AC has a rectifying circuit built-in.
** Class H is AC only. No rectifying circuit.
***Please consult with SMC regarding other voltages.

Material and insulation type

Symbol	Body material	Seal material	Coil insulation type
Nil	C37	FKM	Class B
D			Class H
H	Stainless steel	FKM	Class B
N			Class H

Orifice size

Symbol	Orifice size (mmø)	Class 2	Class 3	Class 4
2	2	○	—	—
3	3	○	○	○
4	4	○	○	○
5	5	○	○	○
7	7	—	○	○

Electrical entry

G	Grommet
C	Conduit
T	Conduit terminal
TL	Conduit terminal with indicator light (Note 1)
D	DIN terminal
DL	DIN terminal with indicator light
DO	DIN terminal (without connector)

* All class B coils come with surge voltage suppressor.
** Available types of electrical entry for type H coil are either G, C or T. (without surge voltage suppressor.)
Note 1) TL is available only for standard specifications valve.

Manifold Option

Blanking plate assembly

VVCW 2 1486-3A-H

Series

2	Class 2
3	Class 3
4	Class 4

Material

Symbol	Plate material	Seal material
H	Stainless steel	FKM

JIS Symbol



This is used by mounting it on the manifold block when a valve is removed for maintenance or when the mounting of an additional valve is planned, etc.

Direct Operated 2 Port Solenoid Valve For Oil Series VCL

Dimensions (N.C.)

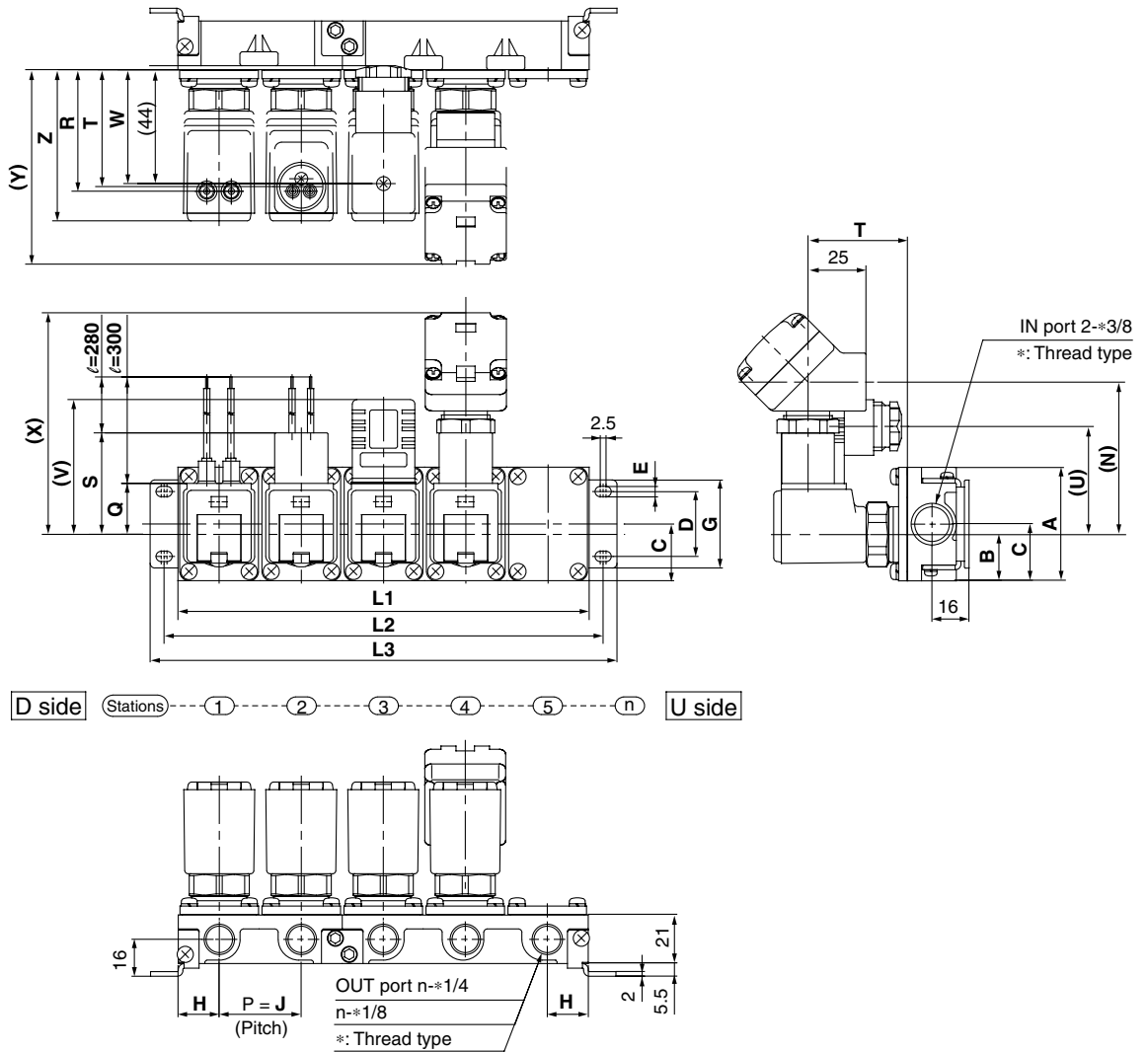

- VC□
- VDW
- VQ
- VX2
- VX□
- VX3
- VXA
- VN□
- LVC
- LVA
- L VH
- LVD
- LVQ
- LQ
- LVN
- TI/
TIL
- PA
- PAX
- PB

L Dimension

Model	Dimensions	n (stations)								
		2	3	4	5	6	7	8	9	10
VV2CL2	L1	69	103.5	138	172.5	207	241.5	276	310.5	345
	L2	81	115.5	150	184.5	219	253.5	288	322.5	357
	L3	93	127.5	162	196.5	231	265.5	300	334.5	369
VV2CL3	L1	77	115.5	154	192.5	231	269.5	308	346.5	385
	L2	89	127.5	166	204.5	243	281.5	320	358.5	397
	L3	101	139.5	178	216.5	255	293.5	332	370.5	409
VV2CL4	L1	83	124.5	166	207.5	249	290.5	332	373.5	415
	L2	95	136.5	178	219.5	261	302.5	344	385.5	427
	L3	107	148.5	190	231.5	273	314.5	356	397.5	439

Manifold composition 2 stns. x 1 3 stns. x 1 2 stns. x 2 2 stns. + 3 stns. 3 stns. x 2 2 stns. x 2 + 3 stns. 2 stns. + 3stns. x 2 3 stns. x 3 2 stns. x 2 + 3 stns. x 2

Note) Manifold base is consisted of the junction of 2 and 3 station bases.

Dimensions

Model	A	B	C	D	E	G	H	J	Z	Electrical entry									
										Grommet			Conduit		DIN terminal			Conduit terminal	
										Q	R	S	T	U	V	W	N	X	Y
VV2CL2	49	20	24.5	28	4.5	38	17.3	34.5	56	22	45.5	44	43.5	46	58	41.5	66	99	77
VV2CL3	57	25.5	28.5	30	5.5	42	19.3	38.5	66	24	55	45.5	53	48	60	51	68	101	86.5
VV2CL4	57	25.5	28.5	30	5.5	42	20.8	41.5	74	26	62.5	47.5	60.5	50	62	58.5	70	103	94