

Direct Operated 2 Port Solenoid Valve For Water

Series VCW

How to Order Valves (Single Unit)

VCW 2 1 1 G 2 02

For water

- When no symbol is shown for "Material and insulation type"
- Body material: C37
- Seal material: NBR
- Coil insulation: Class B

Series

2	Class 2
3	Class 3
4	Class 4

Valve type

1 N.C. (Normally Closed)
2 N.O. (Normally Open)

Voltage

1	100 VAC
2	200 VAC
3	110 VAC
4	220 VAC
5	24 VDC
6	12 VDC
36	230 VAC

* Please consult with SMC regarding other voltages.

Electrical entry

G - Grommet	C - Conduit
T - Conduit terminal TL - Conduit terminal with indicator light	D - DIN terminal DL - DIN terminal with indicator light DO - DIN terminal (without connector)

* All types are equipped with surge voltage suppressor.

Option

Nil	None
F	Foot type bracket

Material and insulation type

Symbol	Body material	Seal material	Coil insulation type	Note
Nil	C37	NBR	B	
A		FKM		
B		EPDM		
C		PTFE		
G	SUS	NBR		
H		FKM		
J		EPDM		
K		PTFE		
L		FKM		Note) For pure water

Note)
High corrosion resistant specification used for armature material.

Thread type

Nil	Rc
F	G
N	NPT

Port size

Symbol	Port size	Class 2	Class 3	Class 4
01	1/8 (6A)	○	—	—
02	1/4 (8A)	○	○	○
03	3/8 (10A)	—	○	○
04	1/2 (15A)	—	○	○
06	3/4 (20A)	—	—	○

Orifice size

Symbol	Orifice size (mm)	Class 2	Class 3	Class 4
2	2	○	—	—
3	3	○	○	○
4	4	○	○	○
5	5	○	○	○
7	7	—	○	○
10	10 (Note)	—	○	○

Note) ø10 is available only for N.C. (normally closed).
* Refer to the below table for orifice and port size combinations.

Orifice and Port Size Combinations

Class	Port size	Orifice size (mm)					
		2	3	4	5	7	10 (Note)
2	1/8 (6A)	●	●	●	●	—	—
	1/4 (8A)	●	●	●	●	—	—
3	1/4 (8A)	—	●	●	●	●	—
	3/8 (10A)	—	●	●	●	●	●
4	1/2 (15A)	—	—	—	—	—	●
	1/4 (8A)	—	●	●	●	●	—
	3/8 (10A)	—	●	●	●	●	●
	1/2 (15A)	—	—	—	—	—	●
	3/4 (20A)	—	—	—	—	—	●

Note) ø10 is available only for N.C. (normally closed).

Direct Operated 2 Port Solenoid Valve For Water Series V CW

Standard Specifications



Valve specifications	Valve construction	Direct operated poppet		
	Fluid ⁽¹⁾	Water Pure water (Except waste water or agricultural water)		
	Withstand pressure (MPa)	5.0		
	Body material	C37, Stainless steel		
	Seal material	NBR, FKM, EPDM, PTFE		
	Ambient temperature (°C)	-20 to 60		
	Fluid temperature (°C)	1 to 60 (No freezing)		
	Enclosure	Dusttight/low jetproof (equivalent to IP65)		
	Environment	Location without corrosive or explosive gases		
	Valve leakage (cm ³ /min)	0 (With water pressure) ⁽³⁾		
	Mounting orientation	Unrestricted		
	Vibration/Impact resistance (m/s ²) ⁽⁴⁾	30/150 or less		
Coil specifications	Rated voltage	24 VDC, 12 VDC, 100 VAC, 110 VAC, 200 VAC, 220 VAC (50/60 Hz)		
	Allowable voltage fluctuation	±10% of rated voltage		
	Coil insulation type	Class B		
	Power consumption	DC	VCW2: 6W, VCW3: 8 W, VCW4: 11.5W	
		AC 50/60 Hz ⁽²⁾	VCW2: 8.5VA, VCW3: 10VA, VCW4: 13VA	



- Note 1) When using pure water, select "L" for the type of material (Stainless steel, FKM).
 Note 2) Since AC coil uses a rectifying circuit, there is no difference in power consumption between inrush and holding.
 Note 3) When using seal material PTFE at 15 cm³/min (under water pressure) or less.
 Note 4) Vibration resistance Conditions when tested with one sweep of 10 to 250 Hz in the axial direction and at a right angle to the armature, in both energized and deenergized states. No malfunction occurred when tested (value at the initial state).
 Impact resistance Conditions when tested with a drop tester in the axial direction and at a right angle to the armature, one time each in energized and deenergized states. No malfunction occurred when tested. (Value at the initial state).

Characteristic Specifications

Model	Class	Port size ⁽¹⁾	Orifice size (mm) ⁽¹⁾	Maximum operating pressure differential		Flow characteristics		Max. system pressure (MPa)	Weight (kg) ⁽²⁾
				N.C. (MPa)	N.O. (MPa)	Av x 10 ⁻⁶ m ²	Cv converted		
VCW2	2	1/8 (6A) 1/4 (8A)	2	2.0	0.9	3.8	0.16	3.0	1/8: 0.21 1/4: 0.24
			3	0.8	0.45	7.9	0.33		
			4	0.5	0.25	12	0.51		
			5	0.3	0.15	16	0.65		
VCW3	3	1/4 (8A) 3/8 (10A) 1/2 (15A)	3	2.0	0.8	8.4	0.35	3.0	1/4: 0.42 3/8: 0.40 1/2: 0.49
			4	0.8	0.42	13	0.54		
			5	0.5	0.23	19	0.80		
			7	0.2	0.13	33	1.4		
			10	0.1	—	50	2.1		
VCW4	4	1/4 (8A) 3/8 (10A) 1/2 (15A) 3/4 (20A)	3	3.0	1.2	8.4	0.35	3.0	1/4: 0.58 3/8: 0.55 1/2: 0.62 3/4: 0.78
			4	1.3	0.73	14	0.60		
			5	0.7	0.47	20	0.85		
			7	0.3	0.22	33	1.4		
			10	0.12	—	50	2.1		



- Note 1) Refer to page 17-2-52 in model selection regarding port size and orifice size combinations.
 Note 2) The weight is the value for the grommet type.

Made to Order Specifications

Please contact SMC for detailed specifications, delivery, and price.



Non-leak (10⁻⁶ Pa·m³/sec), vacuum (0.1 Pa·abs) specifications

VCW□□-□□-□-□□□-**A**-□-□-**X35**

Oil-free specifications

VCW□□-□□-□-□□□-□-□-□-**X40**

VC□

VDW

VQ

VX2

VX□

VX3

VXA

VN□

LVC

LVA

LVH

LVD

LVQ

LQ

LVN

TI/
TIL

PA

PAX

PB

Series VCW

Construction

N.C.

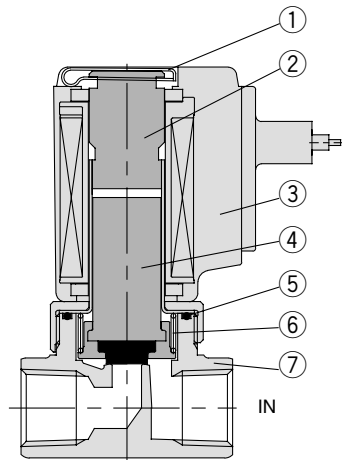

N.O.

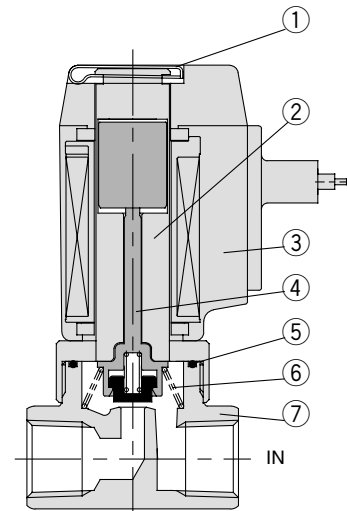

Component Parts

No.	Description	Material	
		Standard	Option
①	Clip	Stainless steel	—
②	Tube assembly	Stainless steel	—
③	Coil assembly	Class B	—
④	Armature assembly	Class 2 Stainless steel, PPS, NBR Class 3 Stainless steel, NBR	Stainless steel, NBR/Stainless steel, FKM, Stainless steel, EPDM/Stainless steel, PTFE
⑤	O-ring	NBR	FKM, EPDM, PTFE
⑥	Return spring	Stainless steel	—
⑦	Body	Brass	Stainless steel

Component parts

No.	Description	Material	
		Standard	Option
①	Clip	Stainless steel	—
②	Tube assembly	Stainless steel, PTFE	—
③	Coil assembly	Class B	—
④	Push rod assembly	PPS-NBR	PPS, NBR/PPS, FKM PPS, EPDM/PPS, PTFE
⑤	O-ring	NBR	FKM, EPDM, PTFE
⑥	Return spring	Stainless steel	—
⑦	Body	Brass	Stainless steel

Dimensions: Bracket

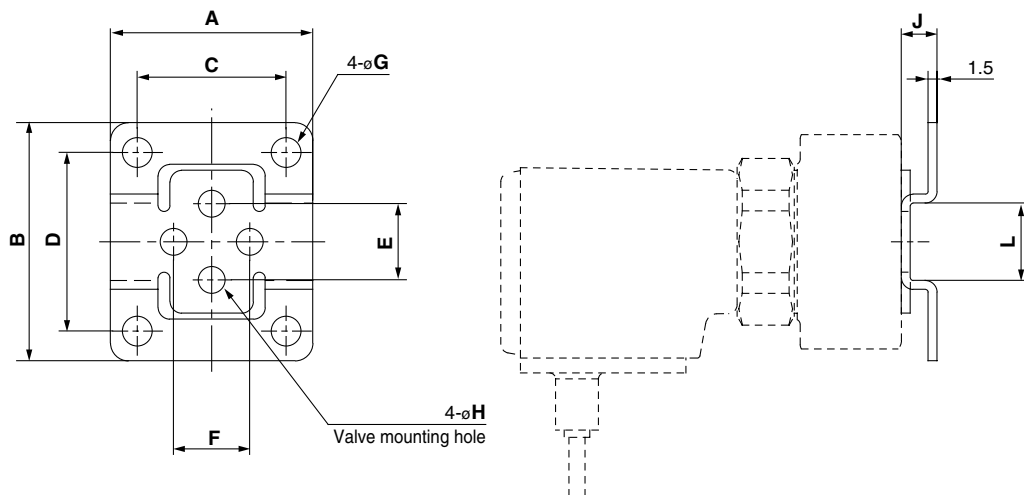

Bracket Mounting Dimensions/Bracket Material: Stainless Steel

Valve model	Port size	Bracket part no.	A	B	C	D	E	F	G	H	J	L
VCW2□	1/8, 1/4	VCW20-12-01A	34	40	25	30	12.8	12.8	5	4.5	6	13
VCW3□	1/4, 3/8	VCW30-12-02A	42	52	30	40	19	19	6	5.5	7	19
	1/2	VCW30-12-04A ^{Note 1)}	48	56	36	44	23	23	6	5.5	7	23
VCW4□	1/4, 3/8	VCW40-12-02A	42	52	30	40	23	23	6	5.5	7	19
	1/2	VCW30-12-04A ^{Note 1)}	48	56	36	44	23	23	6	5.5	7	23
	3/4	VCW40-12-06A	56	65	44	53	28.2	28.2	6	5.5	7	26

* 2 mounting screws (for mounting bracket) are included in bracket part no.

Note 1) The same bracket is used for VCW3□ and VCW4□ (port size 1/2).

Direct Operated 2 Port Solenoid Valve For Water Series V CW

Dimensions (N.C.)

Grommet: G

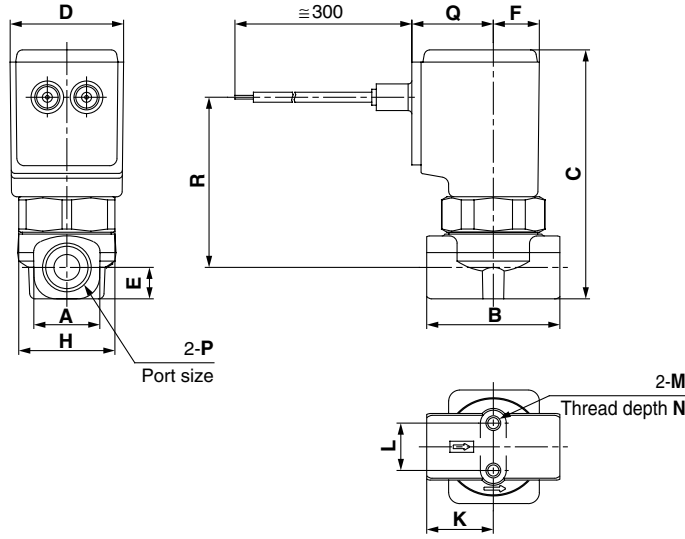

Conduit: C

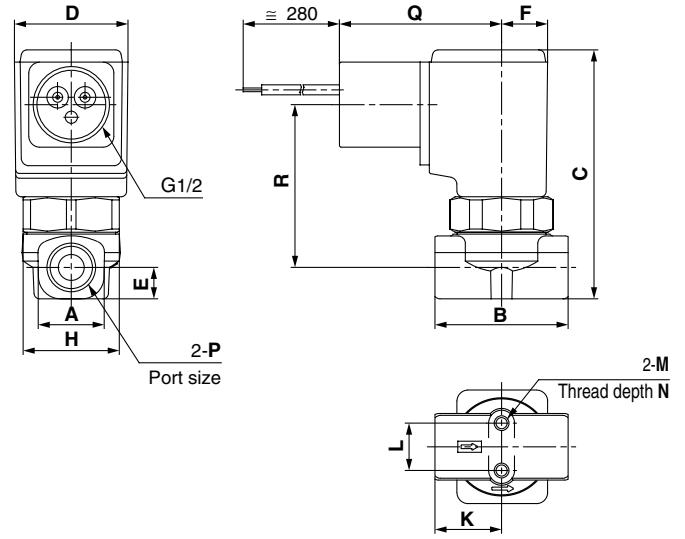

DIN terminal: D

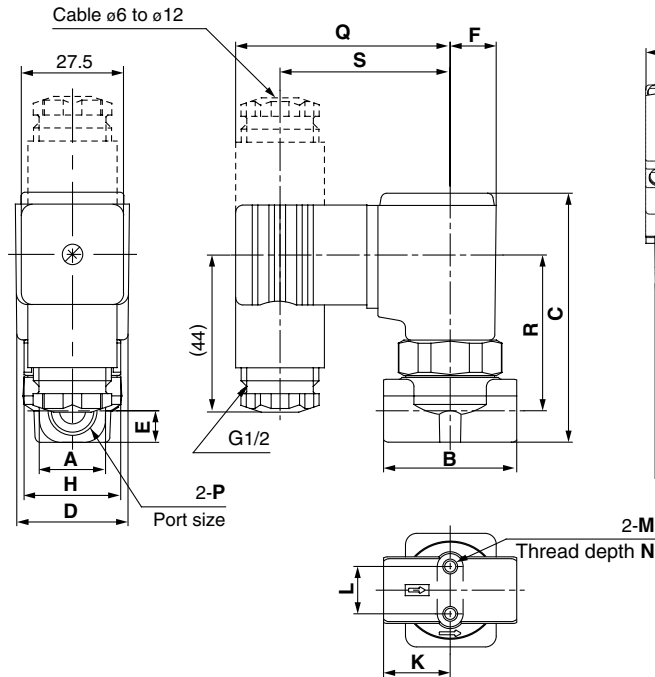

Conduit terminal: T

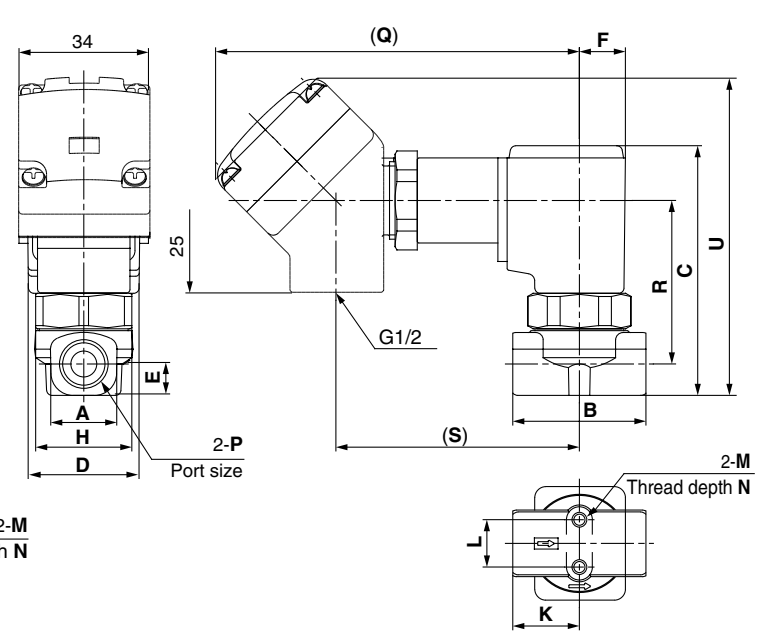

- VC□
- VDW
- VQ
- VX2
- VX□
- VX3
- VXA
- VN□
- LVC
- LVA
- LVH
- LVD
- LVQ
- LQ
- LVN
- TI/
TIL
- PA
- PAX
- PB

N.C.

(mm)

Model	P Port size	A	B	C	D	E	F	H	K	L	M	N	Electrical entry										
													Grommet: G		Conduit: C		DIN terminal: D			Conduit terminal: T			
													Q	R	Q	R	Q	R	S	Q	R	S	U
VCW21	1/8	13.5	28	64	31	6.5	12.5	28	14	12.8	M4	4.5	22	45	44	43	58	40.5	46.5	99	43	66	83
	1/4	18	36	67.5	31	8.5	12.5	28	18	12.8	M4	6	22	46	44	44	58	41.5	46.5	99	44	66	86
VCW31	1/4, 3/8	22	40	81.5	36.5	11	15	32	20	19	M5	8	24	56.5	46	54.5	60	52	48.5	101	54.5	68	99
	1/2	30	50	86	36.5	13.5	15	32	25	23	M5	8	24	59	46	57	60	54.5	48.5	101	57	68	104
VCW41	1/4, 3/8	22	45	90	41	11	17	36	22.5	23	M5	8	26	64.5	48	62.5	62	60	50.5	103	62.5	70	107
	1/2	30	50	94	41	13.5	17	36	25	23	M5	8	26	66.5	48	64.5	62	62	50.5	103	64.5	70	111.5
	3/4	35	60	102	41	17.5	17	36	30	28.2	M5	8	26	70	48	68	62	65.5	50.5	103	68	70	119

Series VCW

Dimensions (N.O.)

Grommet: G

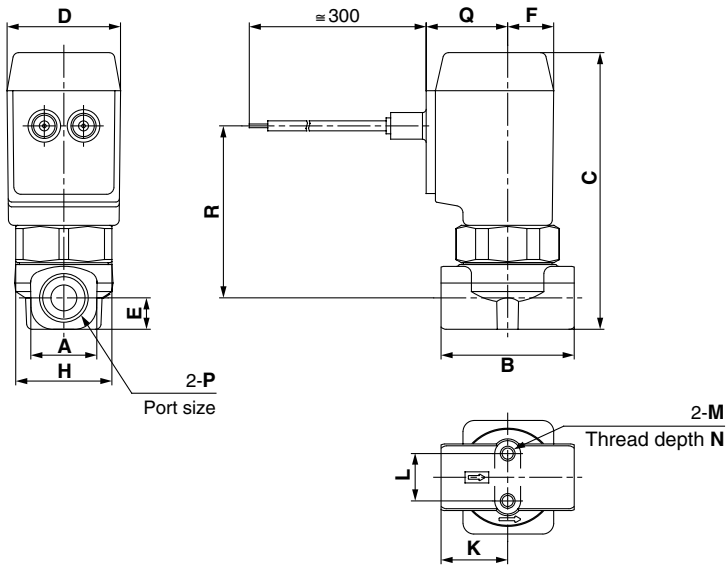

Conduit: C

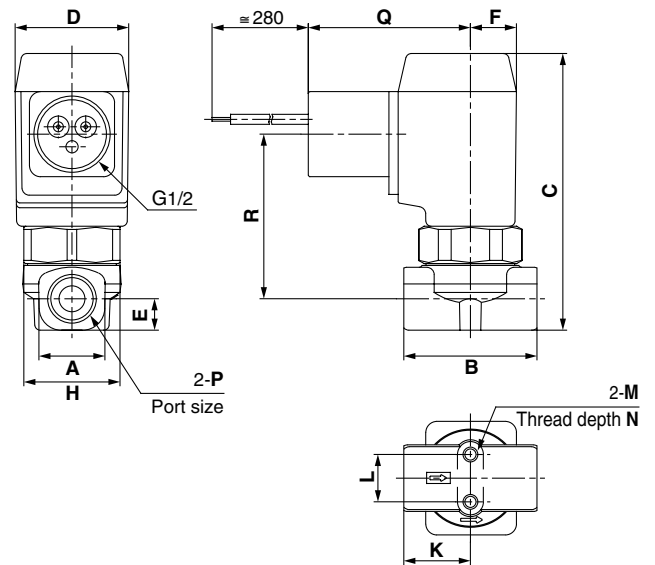

DIN terminal: D

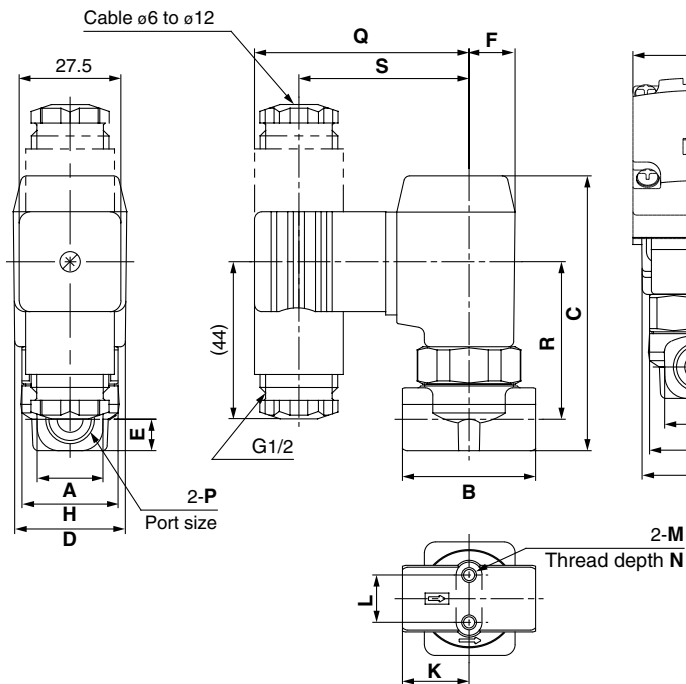

Conduit terminal: T

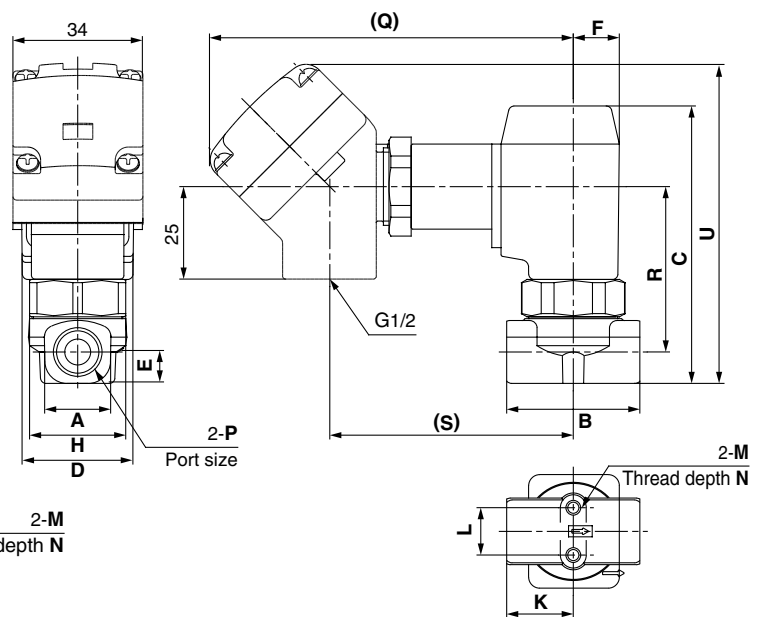

N.O.

(mm)

Model	P Port size	A	B	C	D	E	F	H	K	L	M	N	Electrical entry										
													Grommet: G		Conduit: C		DIN terminal: D			Conduit terminal: T			
													Q	R	Q	R	Q	R	S	Q	R	S	U
VCW22	1/8	13.5	28	71.5	31	6.5	12.5	28	14	12.8	M4	4.5	22	45.5	44	43.5	58	41	46.5	99	43.5	66	83
	1/4	18	36	75	31	8.5	12.5	28	18	12.8	M4	6	22	46.5	44	44.5	58	42	46.5	99	44.5	66	86
VCW32	1/4, 3/8	22	40	89.5	36.5	11	15	32	20	19	M5	8	24	57	46	55	60	52.5	48.5	101	55	68	99
VCW42	1/4, 3/8	22	45	97.5	41	11	17	36	22.5	23	M5	8	26	65	48	63	62	60.5	50.5	103	63	70	107
	1/2	30	50	101.5	41	13.5	17	36	25	23	M5	8	26	67	48	65	62	62.5	50.5	103	65	70	111.5

How to Order Manifold

VV2C W 2 02 01

For water
When there is no symbol for material
• Manifold material: C37
• Seal material: NBR (4 stations or more)

Series

2	Class 2
3	Class 3
4	Class 4

Material

Symbol	Base material	Seal material
Nil	C37	NBR
A		FKM
B		EPDM
C		PTFE
G	Stainless steel	NBR
H		FKM
J		EPDM
K		PTFE

Stations

02	2 stations
...	...
10	10 stations

* Refer to page 17-2-58/59 in the L dimension table regarding the maximum number of stations.

Thread type

Symbol	Thread type
Nil	Rc
N	NPT
F	G

OUT port size

Symbol	Port size
01	1/8 (6A)
02	1/4 (8A)

* All IN ports are 3/8.



How to Order Manifold Assembly

Enter the mounting valve and option part numbers under the manifold base part number.

<Ordering Example>

VV2CW2-0501..... 1 set Manifold part no.
* VCV23-5G-2..... 5 sets Valve part no. (Stations 1 to 5)

"*" is the symbol for assembly. Add an "*" in front of the part numbers for solenoid valves, etc., to be mounted.

Enter together in order, counting from station 1 on the D side.

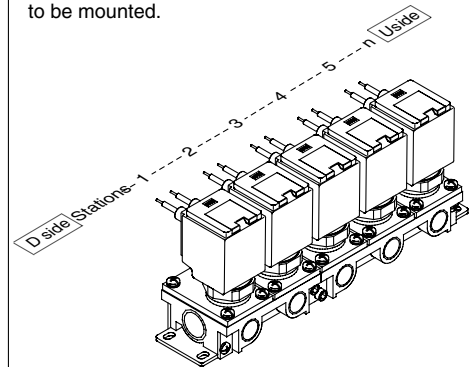

How to Order Valves (For Manifold)

VC W 2 3 1 G 2

For water
When there is no symbol for material and type of insulation
• Body material: C37
• Seal material: NBR
• Coil insulation: Class B

Series

2	Class 2
3	Class 3
4	Class 4

Valve type

3	N.C. for manifold
4	N.O. for manifold

Material and insulation type

Symbol	Body material	Seal material	Coil insulation type	Note
Nil	C37	NBR	B	
A		FKM		
B		EPDM		
C		PTFE		
G	SUS	NBR		
H		FKM		
J		EPDM		
K		PTFE		
L		FKM		

Note) High corrosion resistant specification used for armature material.

Orifice size

Symbol	Orifice size (mm)	Class 2	Class 3	Class 4
2	2	○	—	—
3	3	○	○	○
4	4	○	○	○
5	5	○	○	○
7	7	—	○	○

Voltage

1	100 VAC
2	200 VAC
3	110 VAC
4	220 VAC
5	24 VDC
6	12 VDC
36	230 VAC

* Please consult with SMC regarding other voltages.

Electrical entry

G	Grommet
C	Conduit
T	Conduit terminal
TL	Conduit terminal with indicator light
D	DIN terminal
DL	DIN terminal with indicator light
DO	DIN terminal (without connector)

* All types are equipped with surge voltage suppressor.

Manifold Option

Blanking plate assembly

VVCW 2 0 - 3A - G

Series

2	Class 2
3	Class 3
4	Class 4

Material

Symbol	Plate material	Seal material
G	Stainless steel	NBR
H		FKM
J		EPDM
K		PTFE

JIS Symbol



This is used by mounting it on the manifold block when a valve is removed for maintenance or when the mounting of an additional valve is planned, etc.

VC

VDW

VQ

VX2

VX

VX3

VXA

VN

LVC

LVA

LVH

LVD

LVQ

LQ

LVN

TI/TIL

PA

PAX

PB

Series VCV

Dimensions (N.C.)

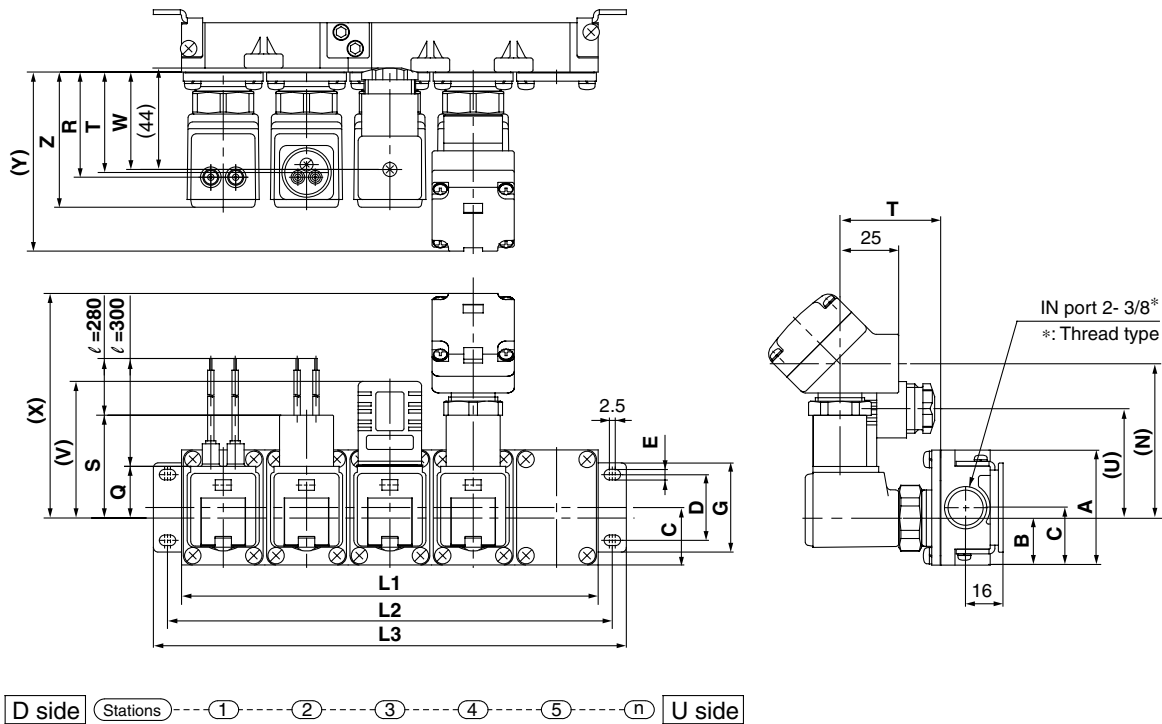

L Dimension

(mm)

Model	Dimensions	n (stations)									
		2	3	4	5	6	7	8	9	10	
VV2CW2	L1	69	103.5	138	172.5	207	241.5	276	310.5	345	
	L2	81	115.5	150	184.5	219	253.5	288	322.5	357	
	L3	93	127.5	162	196.5	231	265.5	300	334.5	369	
VV2CW3	L1	77	115.5	154	192.5	231	269.5	308	346.5	385	
	L2	89	127.5	166	204.5	243	281.5	320	358.5	397	
	L3	101	139.5	178	216.5	255	293.5	332	370.5	409	
VV2CW4	L1	83	124.5	166	207.5	249	290.5	332	373.5	415	
	L2	95	136.5	178	219.5	261	302.5	344	385.5	427	
	L3	107	148.5	190	231.5	273	314.5	356	397.5	439	
Manifold composition	2 stns. x 1	3 stns. x 1	2 stns. x 2	2 stns. + 3stns.	3 stns. x 2	2 stns. x 2 + 3 stns.	2 stns. + 3 stns. x 2	3 stns. x 3	2 stns. x 2 + 3 stns. x 2		

Note) Manifold base is consisted of the junction of 2 and 3 station bases.

Dimensions

(mm)

Model	A	B	C	D	E	G	H	J	Z	Electrical entry									
										Grommet		Conduit		DIN terminal			Conduit terminal		
										Q	R	S	T	U	V	W	N	X	Y
VV2CW2	49	20	24.5	28	4.5	38	17.3	34.5	56	22	45.5	44	43.5	46	58	41.5	66	99	77
VV2CW3	57	25.5	28.5	30	5.5	42	19.3	38.5	66	24	55	45.5	53	48	60	51	68	101	86.5
VV2CW4	57	25.5	28.5	30	5.5	42	20.8	41.5	74	26	62.5	47.5	60.5	50	62	58.5	70	103	94

Direct Operated 2 Port Solenoid Valve For Water Series VCV

Dimensions (N.O.)

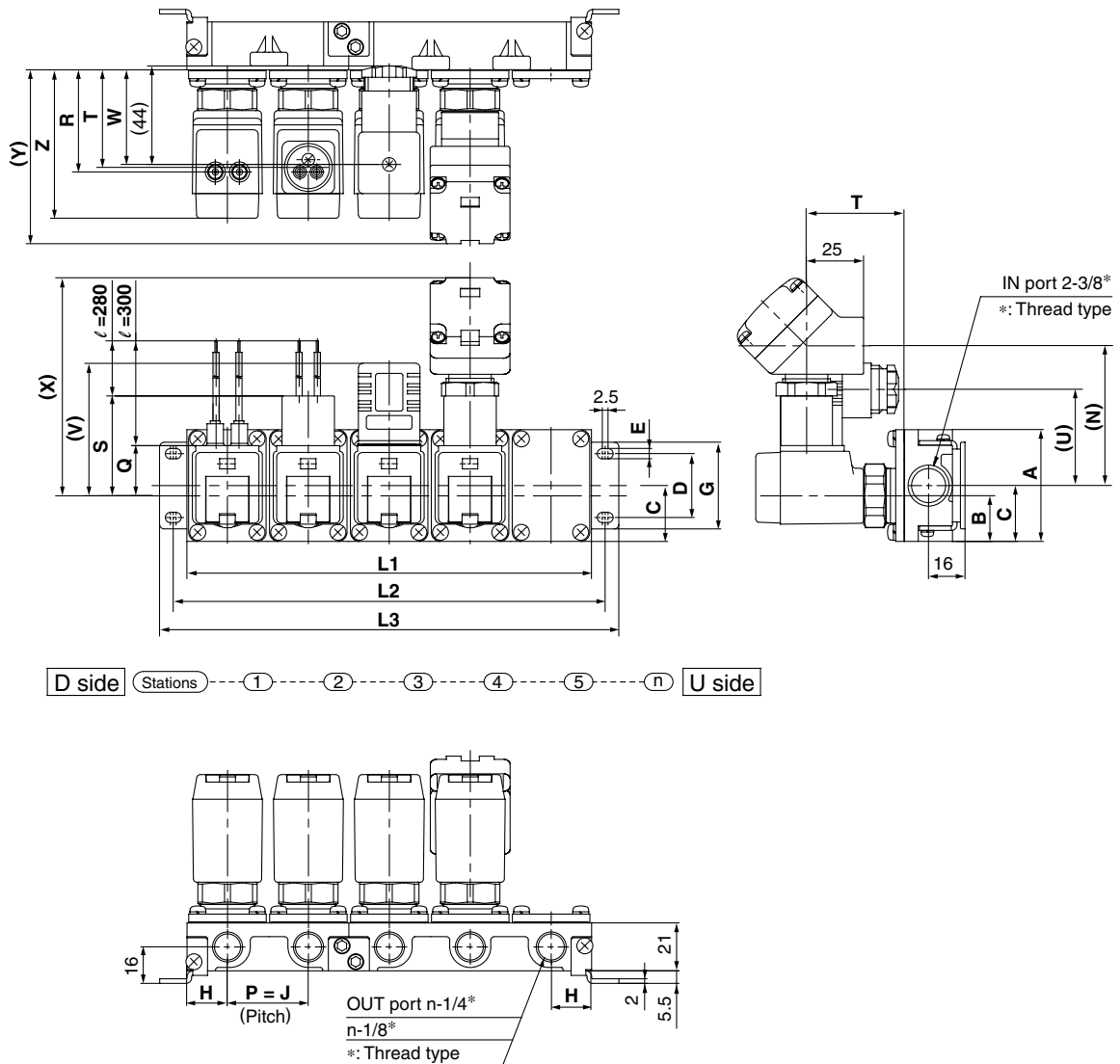

VC□

VDW

VQ

VX2

VX□

VX3

VXA

VN□

LVC

LVA

L VH

LVD

LVQ

LQ

LVN

T/ TIL

PA

PAX

PB

L Dimension

Model	Dimensions	n (stations)									
		2	3	4	5	6	7	8	9	10	
VV2CW2	L1	69	103.5	138	172.5	207	241.5	276	310.5	345	
	L2	81	115.5	150	184.5	219	253.5	288	322.5	357	
	L3	93	127.5	162	196.5	231	265.5	300	334.5	369	
VV2CW3	L1	77	115.5	154	192.5	231	269.5	308	346.5	385	
	L2	89	127.5	166	204.5	243	281.5	320	358.5	397	
	L3	101	139.5	178	216.5	255	293.5	332	370.5	409	
VV2CW4	L1	83	124.5	166	207.5	249	290.5	332	373.5	415	
	L2	95	136.5	178	219.5	261	302.5	344	385.5	427	
	L3	107	148.5	190	231.5	273	314.5	356	397.5	439	

Manifold composition 2 stns. x 1 3 stns. x 1 2 stns. x 2 2 stns. + 3 stns. 3 stns. x 2 2 stns. x 2 + 3 stns. 2 stns. + 3 stns. x 2 3 stns. x 3 2 stns. x 2 + 3 stns. x 2

Note) Manifold base is consisted of the junction of 2 and 3 station bases.

Dimensions

Model	A	B	C	D	E	G	H	J	Z	Electrical entry									
										Grommet		Conduit		DIN terminal			Conduit terminal		
										Q	R	S	T	U	V	W	N	X	Y
VV2CW2	49	20	24.5	28	4.5	38	17.3	34.5	63.5	22	45.5	44	43.5	46	58	41.5	66	99	77
VV2CW3	57	25.5	28.5	30	5.5	42	19.3	38.5	74	24	55	45.5	53	48	60	51	68	101	86.5
VV2CW4	57	25.5	28.5	30	5.5	42	20.8	41.5	81.5	26	62.5	47.5	60.5	50	62	58.5	70	103	94