

5 Port Pilot Operated Solenoid Valve Rubber Seal, Plug-in/Non Plug-in Series **VFR2000**

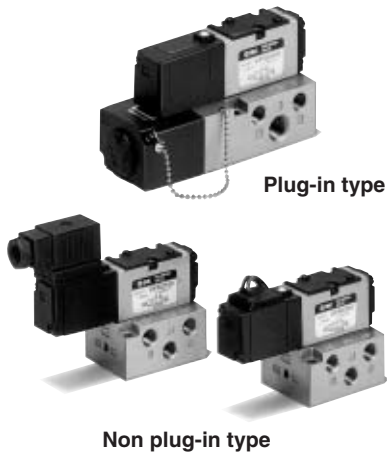

JIS Symbol

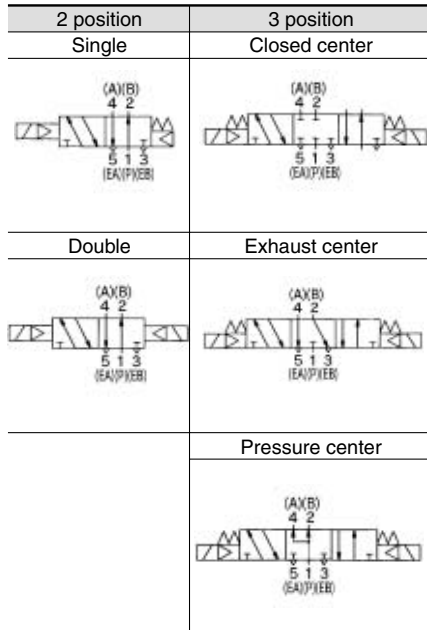

Standard Specifications

Valve specifications		Air	
Operating pressure range	2 position single/3 position	0.2 to 0.9 MPa	
	2 position double	0.1 to 0.9 MPa	
Ambient and fluid temperature		-10 to 50°C (No freezing. Refer to page 3-13-4.)	
Lubrication		Not required ⁽¹⁾	
Manual override		Non-locking push type	
Mounting orientation		Unrestricted	
Shock/Vibration resistance		300/50 m/s ² ⁽²⁾	
Enclosure		Dustproof	
Coil rated voltage		100, 200 VAC (50/60 Hz), 24 VDC	
Allowable voltage fluctuation		-15 to -10% of rated voltage	
Apparent power (AC) ⁽³⁾	Inrush	5.6 VA/50 Hz, 5.0 VA/60 Hz	
	Holding	3.4 VA (2.1 W)/50 Hz, 2.3 VA (1.5 W)/60 Hz	
Power consumption (DC) ⁽³⁾		1.8 W	
Electrical entry	Plug-in type	Conduit terminal	
	Non plug-in type	Grommet, Grommet terminal Conduit terminal, DIN terminal L plug connector, M plug connector	



Note 1) Use turbine oil Class 1 (ISO VG32), if lubricated. Note 2) Impact resistance: No malfunction occurred when it is tested with a drop tester in the axial direction and at the right angles to the main valve and armature in both energized and de-energized states every once for each condition. (Values at the initial period)

Vibration resistance: No malfunction occurred in a one-sweep test between 45 and 2000 Hz. Test was performed at both energized and de-energized states in the axial direction and at the right angles to the main valve and armature. (Values at the initial period)

Option Specifications

Pilot type	External pilot ^{Note)}
Manual override	Non-locking push type A (Extended), Locking type B (Tool required), Locking type C (Lever)
Coil rated voltage	110 to 120, 220, 240 VAC 50/60 Hz 12, 100 VDC
Porting specifications	Bottom ported
Option	With light/surge voltage suppressor



Note) Operating pressure: 0 to 0.9 MPa
Pilot pressure: 2 position single/3 position 0.2 to 0.9 MPa
2 position double 0.1 to 0.9 MPa

Model

Type of actuation	Model		Port size Rc	Flow characteristics ⁽¹⁾						Max. operating cycle ⁽²⁾ (Hz)	Response time ⁽³⁾ (ms)	Weight ⁽⁴⁾ (kg)	
	Plug-in	Non plug-in		1 → 4/2 (P → A/B)			4/2 → 5/3 (A/B → EA/EB)						
				C [dm ³ /(s·bar)]	b	Cv	C [dm ³ /(s·bar)]	b	Cv				
2 position	Single	VFR2100	VFR2110	1/8	2.5	0.18	0.58	3.0	0.27	0.70	10	20 or less	0.34 (0.32)
		VFR2200	VFR2210	1/4	2.8	0.24	0.62	3.0	0.27	0.70			
	Double	VFR2200	VFR2210	1/8	2.4	0.21	0.56	3.1	0.28	0.74	10	20 or less	0.42 (0.44)
		VFR2200	VFR2210	1/4	2.6	0.27	0.62	3.1	0.28	0.74			
3 position	Closed center	VFR2300	VFR2310	1/8	1.3	0.45	0.36	1.4	0.46	0.41	5	30 or less	0.43 (0.45)
		VFR2300	VFR2310	1/4	1.3	0.45	0.36	1.4	0.46	0.41			
	Exhaust center	VFR2400	VFR2410	1/8	0.79	0.53	0.24	3.1 [0.89]	0.24 [0.51]	0.74 [0.27]	5	30 or less	0.43 (0.45)
		VFR2400	VFR2410	1/4	0.79	0.53	0.24	3.1 [0.89]	0.24 [0.51]	0.74 [0.27]			
	Pressure center	VFR2500	VFR2510	1/8	2.8 [0.65]	0.24 [0.60]	0.68 [0.21]	0.89	0.53	0.27	5	30 or less	0.43 (0.45)
		VFR2500	VFR2510	1/4	3.2 [0.75]	0.26 [0.55]	0.73 [0.23]	0.89	0.53	0.27			



Note 1) []: Denotes the normal position.
Note 2) Min. operating frequency is once in 30 days. (As per JIS B 8375)
Note 3) Based on dynamic performance test, JIS B 8375-1981. (0.5 MPa, Coil temperature: 20°C, at rated voltage, without surge voltage suppressor)
Note 4) For VFR2□00-□FZ-₀₂, (): VFR2□10-□DZ-₀₂

Series VFR2000

How to Order

Electrical entry

F: Plug-in type

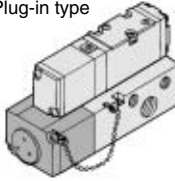
Option

Nil	None
Z	With light/surge voltage suppressor

Piping (P, A, B, EA, EB port)

Nil	Side ported
B *	Bottom ported

* Option

Port size (P, A, B port)

Nil	Without sub-plate
01	1/8
02	1/4

EA, EB port: Rc 1/8

Thread type

Nil	Rc
F	G
N	NPT
T	NPTF

Plug-in VFR2 1 00 [] 5 F [] [] [] 01 []

Non plug-in VFR2 1 10 [] 1 E [] [] [] 02 []

Pilot valve manual override

Nil: Non-locking push type	A*: Non-locking push type A (Extended)	B*: Locking type B (Tool required)	C*: Locking type C (Lever)
----------------------------	--	------------------------------------	----------------------------

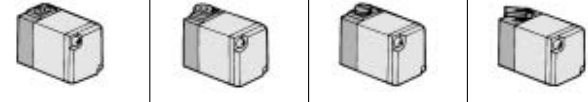

* Option

Option

Nil	None
Z	With light/surge voltage suppressor
S *	With surge voltage suppressor

* Indicator light is not available for grommet type. With surge voltage suppressor is available for grommet type only.

Electrical entry

G: Grommet	E: Grommet terminal	T: Conduit terminal	D, Y: DIN terminal
------------	---------------------	---------------------	--------------------

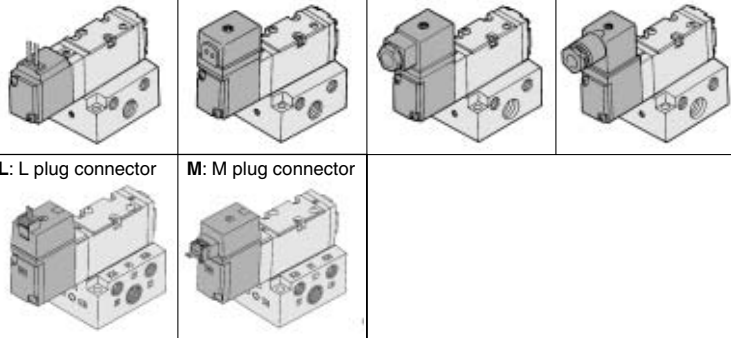

Symbol

1	2 position single (A/B)
2	2 position double (A/B)
3	3 position closed center (A/B)
4	3 position exhaust center (A/B)
5	3 position pressure center (A/B)

Pilot type

Nil	Internal pilot
R *	External pilot

* Option (External pilot is available only on sub-plate type.)

Coil rated voltage

1	100 VAC, 50/60 Hz
2	200 VAC, 50/60 Hz
3 *	110 V to 120 VAC, 50/60 Hz
4 *	220 VAC, 50/60 Hz
5	24 VDC
6 *	12 VDC
7 *	240 VAC, 50/60 Hz
9 *	Other

* Option

How to Order Pilot Valve Assembly

SF4 - 1 DZ [] - 60

Manual override

Nil	Non-locking push type
A *	Non-locking push type A (Extended)
B *	Locking type B (Tool required)
C *	Locking type C (Lever)

* Option

Coil rated voltage

1	100 VAC, 50/60 Hz
2	200 VAC, 50/60 Hz
3 *	110 to 120 VAC 50/60 Hz
4 *	220 VAC, 50/60 Hz
5	24 VDC
6 *	12 VDC
7 *	240 VAC, 50/60 Hz
9 *	Other

* Option

Electrical entry, Light/Surge voltage suppressor

Symbol	Electrical entry	Indicator light	With surge voltage suppressor	Body type	Symbol	Electrical entry	Indicator light	With surge voltage suppressor	Body type	
F	Plug-in	—	—	Plug-in type	T	Conduit terminal	—	—	Non plug-in type	
G	Grommet	—	—	Non plug-in type	TZ	Grommet terminal	●	●		
GS		—	●		E		L plug connector	—		—
D	DIN terminal	With connector	—		LZ	L plug connector (Without connector)		●		●
DZ		Without connector	—		LO		M plug connector	—		—
DO	—	—	DOZ		M plug connector (Without connector)	●		●		
DOZ	—	—	Y			M plug connector (Without connector)	—	—		
Y	DIN terminal (DIN43650B)	With connector	—		M		M plug connector	●		●
YZ		Without connector	—		MO			M plug connector (Without connector)		—
YO	—	—	MOZ		●		●			
YOZ	—	—								

5 Port Pilot Operated Solenoid Valve Rubber Seal, Plug-in/Non Plug-in Series VFR2000

Use as a guide for selection.
Please confirm the actual conditions with SMC
Sizing Program.

Cylinder Speed Chart

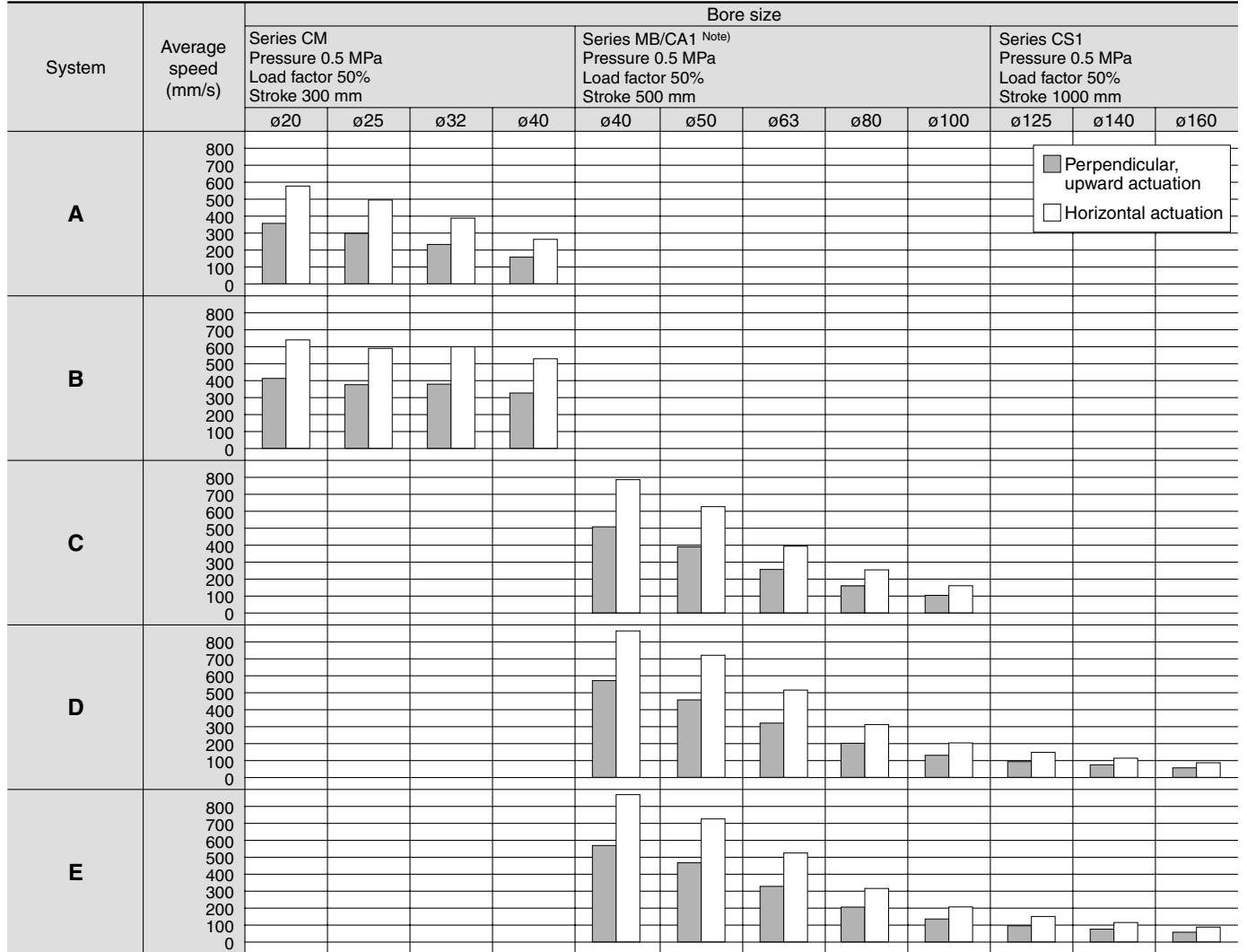

- VK
- VZ
- VF
- VFR**
- VP4
- VZS
- VFS
- VS4
- VQ7
- EVS
- VFN

* It is when the cylinder is extending that is meter-out controlled by speed controller which is directly connected with cylinder, and its needle valve with being fully open.
 * The average velocity of the cylinder is what the stroke is divided by the total stroke time.
 * Load factor: ((Load weight x 9.8)/Theoretical force) x 100%
 Note) The Series CA1 has been changed to the Series CA2.

System Components

System	Solenoid valve	Speed controller	Silencer	Tube bore x Length
A	Series VFR2000 Rc 1/8	AS2000-01 (S = 2.5 mm ²)	AN110-01 (S = 35 mm ²)	T0425 x 1 m
B		AS3000-02 (S = 12 mm ²)	AN110-01 (S = 35 mm ²)	T0604 x 1 m
C		AS3000-02 (S = 12 mm ²)	AN110-01 (S = 35 mm ²)	T0806 x 1 m
D	Series VFR2000 Rc 1/4	AS4000-02 (S = 21 mm ²)	AN110-01 (S = 35 mm ²)	T1075 x 1 m
E		AS4000-02 (S = 21 mm ²)	AN110-01 (S = 35 mm ²)	T1209 x 1 m

How to Order Sub-plate Assembly

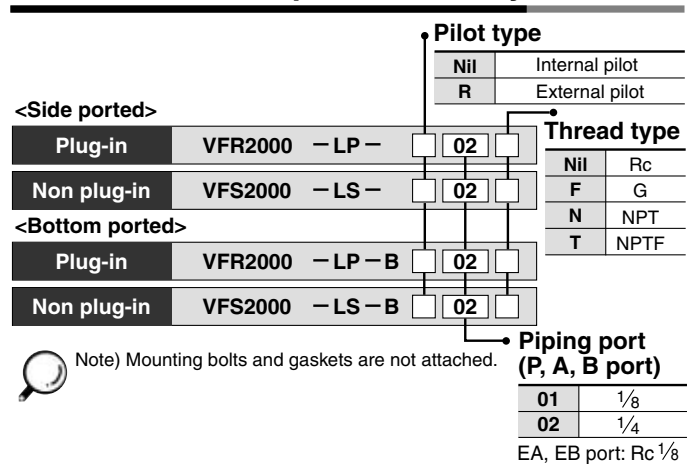

Series VFR2000

Construction

2 position single

2 position double

VFR21□0

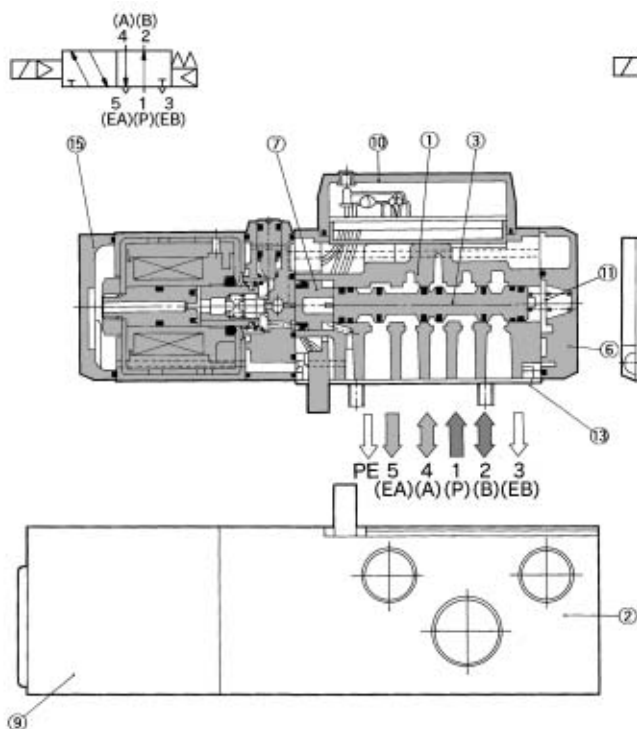

VFR22□0

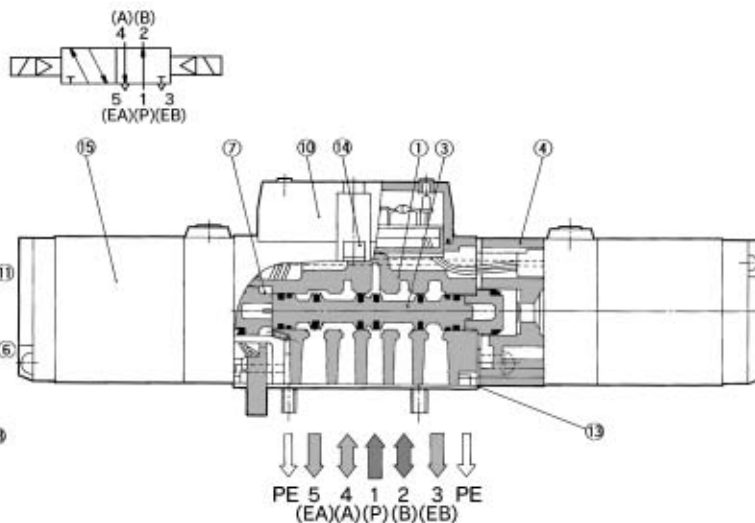

3 position closed center/exhaust center/pressure center

Closed center: VFR23□0

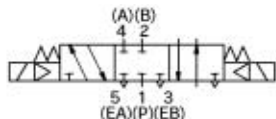

Exhaust center: VFR24□0



Pressure center: VFR25□0

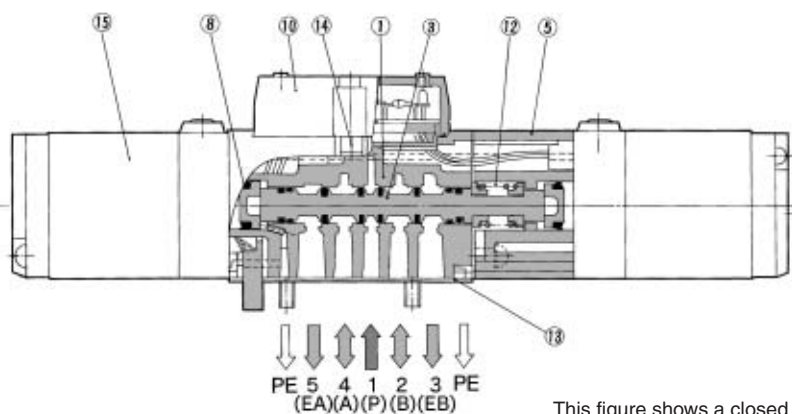
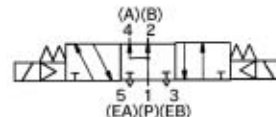

This figure shows a closed center type.

Component Parts

No.	Description	Material	Note
①	Body	Aluminum die-casted	Platinum silver
②	Sub-plate	Aluminum die-casted	Platinum silver
③	Spool valve	Aluminum, NBR	
④	Adapter plate	Aluminum die-casted	Platinum silver
⑤	Adapter plate	Aluminum die-casted	Platinum silver
⑥	End plate	Resin	Black

No.	Description	Material	Note
⑦	Piston	Resin	
⑧	Piston	Resin	
⑨	Junction cover	Resin	
⑩	Light cover assembly	Resin	
⑪	Spool spring	Stainless steel	
⑫	Return spring	Stainless steel	

Replacement Parts

No.	Description	Material	Part no.		
			VFR21□0	VFR22□0	VFR23□0/24□0/25□0
⑬	Gasket	NBR	AXT624-20-2	AXT624-20-2	AXT624-20-2
⑭	Hexagon socket head screw	Steel	AXT624-26 (M3 x 31)	AXT624-26 (M3 x 31)	AXT624-26 (M3 x 31)
⑮	Pilot valve assembly	—	Refer to "How to Order Pilot Valve Assembly" on page 3-5-10.		
—	Sub-plate assembly	—	Refer to "How to Order Sub-plate Assembly" on page 3-5-11.		

5 Port Pilot Operated Solenoid Valve Rubber Seal, Plug-in/Non Plug-in Series VFR2000

Plug-in 2 position single/double, 3 position closed center/exhaust center/pressure center

2 position single: VFR2100-□F-⁰¹/₀₂

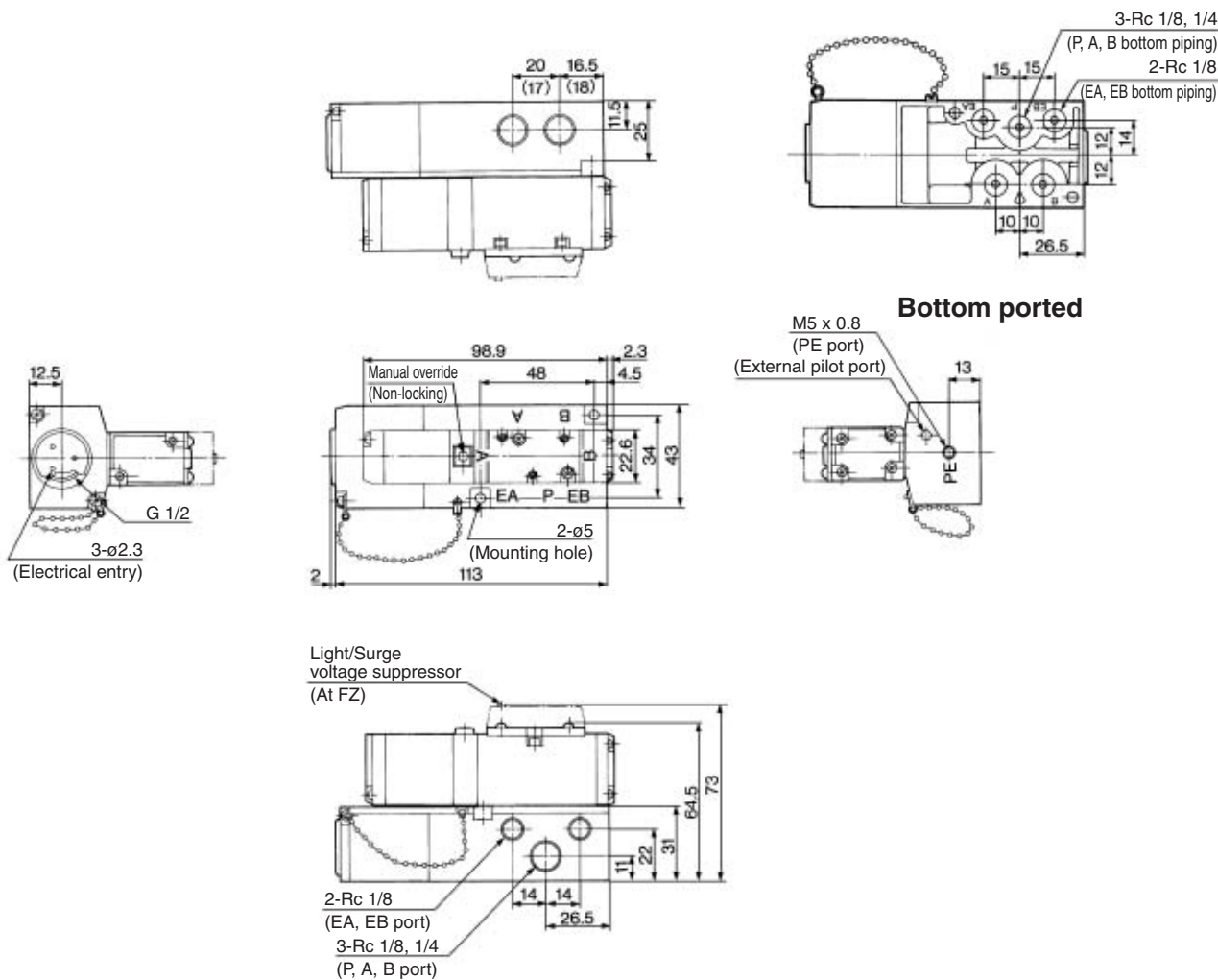

- VK
- VZ
- VF
- VFR
- VP4
- VZS
- VFS
- VS4
- VQ7
- EVS
- VFN

2 position double: VFR2200-□F-⁰¹/₀₂

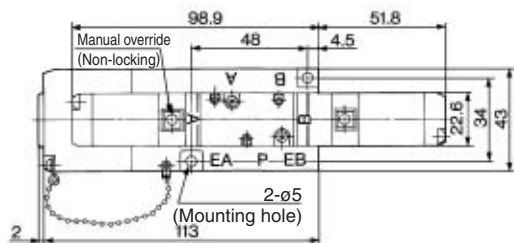

* Other dimensions are the same as the single type.

3 position closed center: VFR2300-□F-⁰¹/₀₂
 3 position exhaust center: VFR2400-□F-⁰¹/₀₂
 3 position pressure center: VFR2500-□F-⁰¹/₀₂

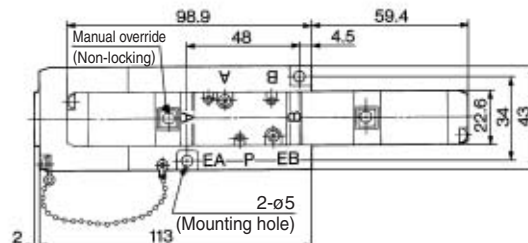

* Other dimensions are the same as the single type.

Series VFR2000

Non Plug-in 2 position single

Grommet: VFR2110-□G-01/02

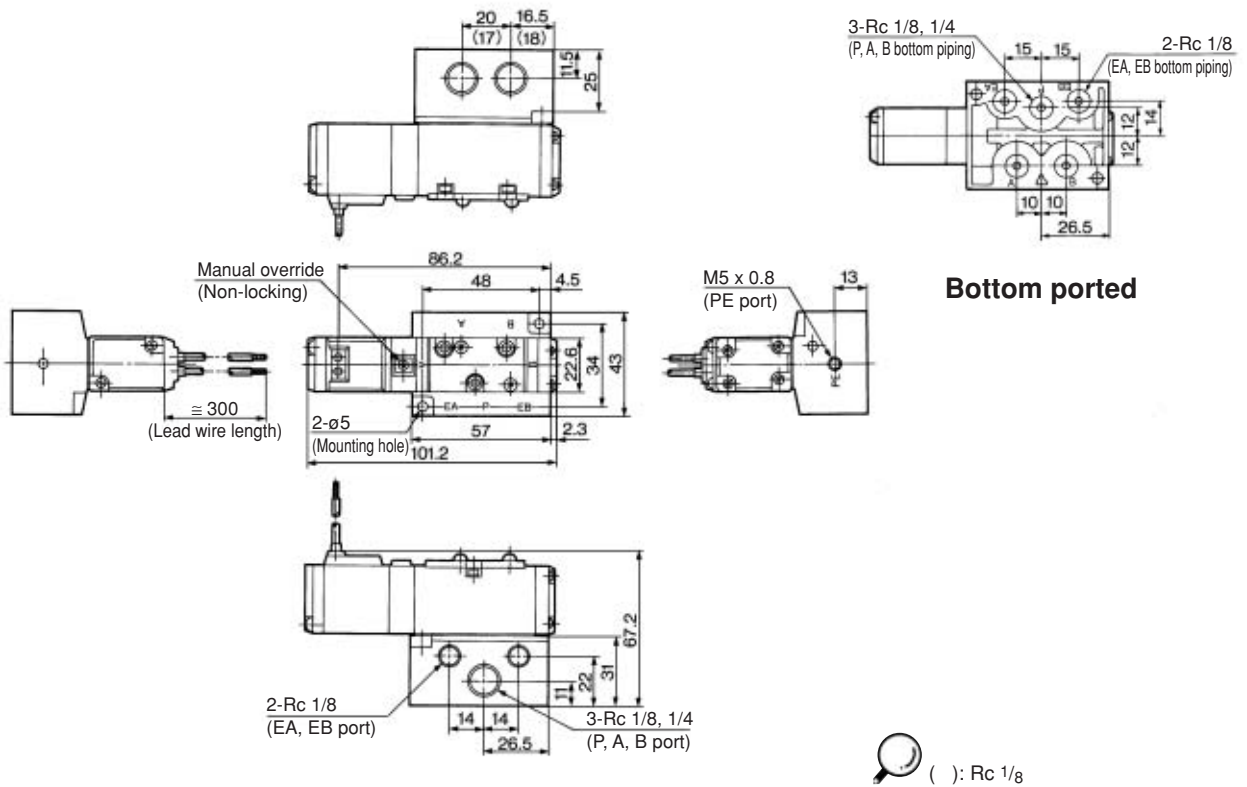

Grommet terminal: VFR2110-□E-01/02

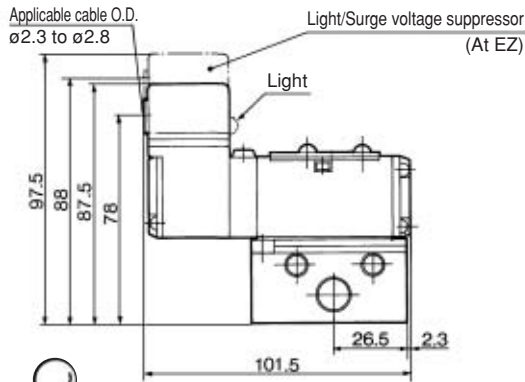

Conduit terminal: VFR2110-□T-01/02

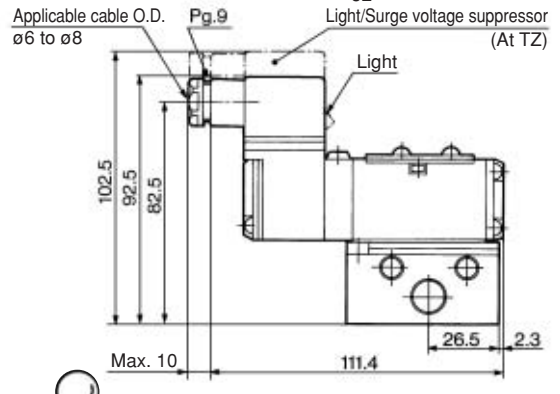

DIN terminal: VFR2110-□D-01/02

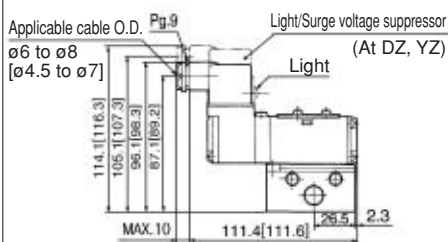

L plug connector: VFR2110-□L-01/02

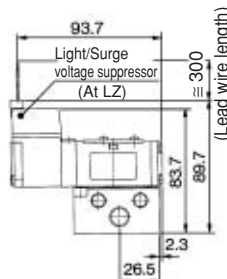

M plug connector: VFR2110-□M-01/02

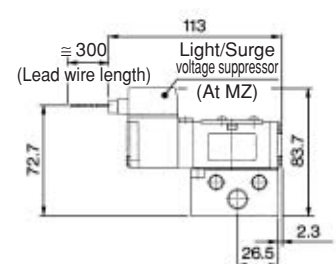

5 Port Pilot Operated Solenoid Valve Rubber Seal, Plug-in/Non Plug-in Series VFR2000

Non Plug-in 2 position double

Grommet: VFR2210-□G-⁰¹/₀₂

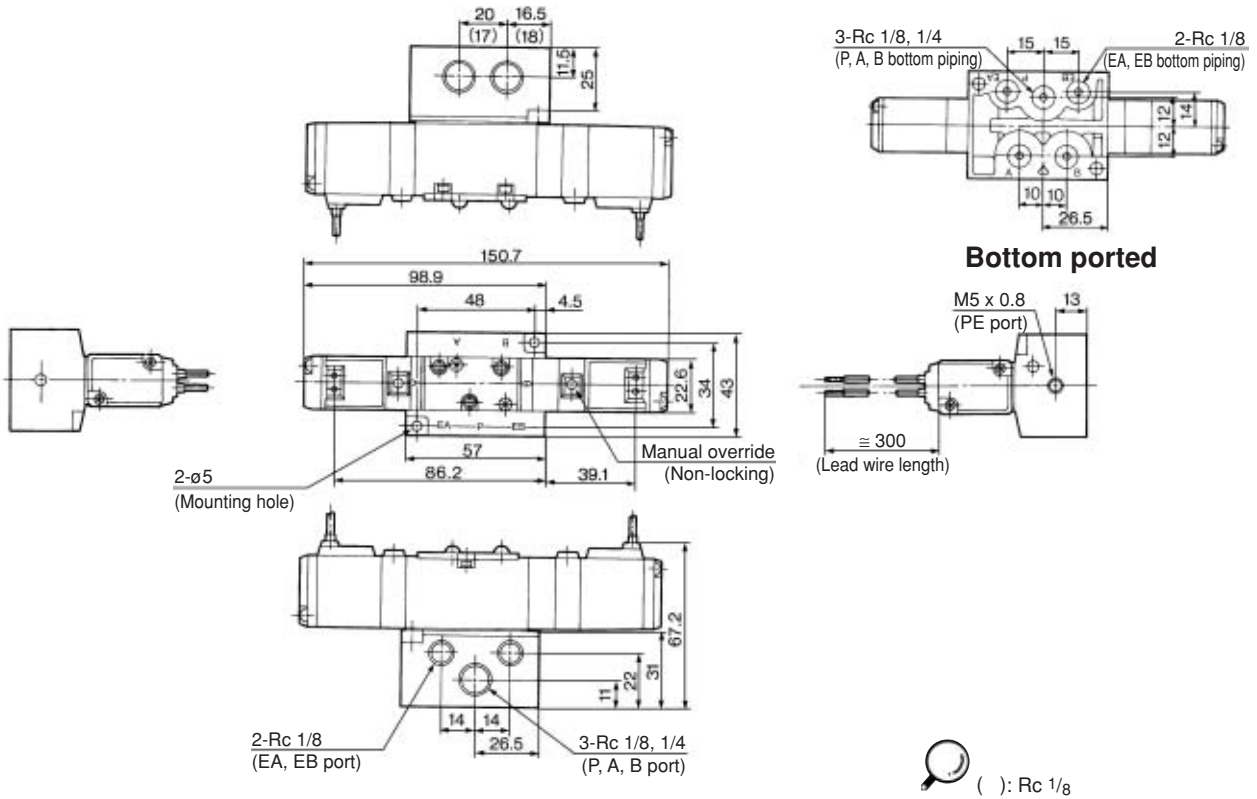

- VK
- VZ
- VF
- VFR**
- VP4
- VZS
- VFS
- VS4
- VQ7
- EVS
- VFN

Grommet terminal: VFR2210-□E-⁰¹/₀₂

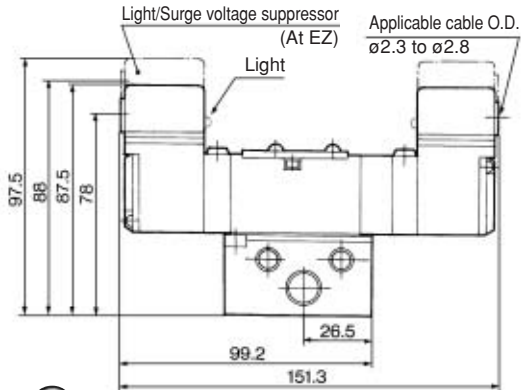

Conduit terminal: VFR2210-□T-⁰¹/₀₂

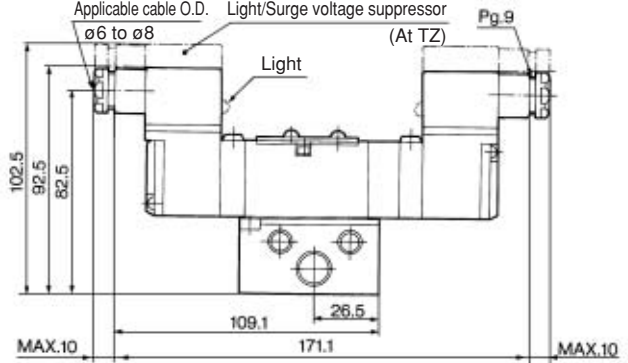

DIN terminal: VFR2210-□^D/_Y-⁰¹/₀₂

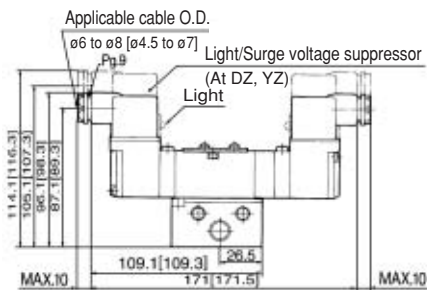

L plug connector: VFR2210-□L-⁰¹/₀₂

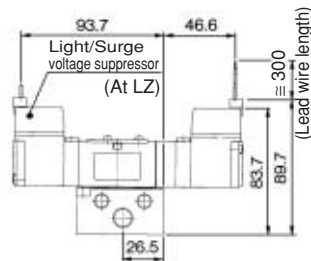

M plug connector: VFR2210-□M-⁰¹/₀₂

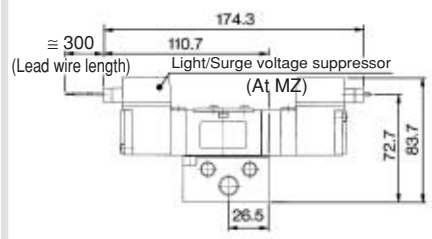

* []: Type Y
* Other dimensions are the same as the grommet type.

* Other dimensions are the same as the grommet type.

* Other dimensions are the same as the grommet type.

Series VFR2000

Non Plug-in 3 position closed center/exhaust center/pressure center

Grommet

Closed center: VFR2310-□G-⁰¹/₀₂
 Exhaust center: VFR2410-□G-⁰¹/₀₂
 Pressure center: VFR2510-□G-⁰¹/₀₂

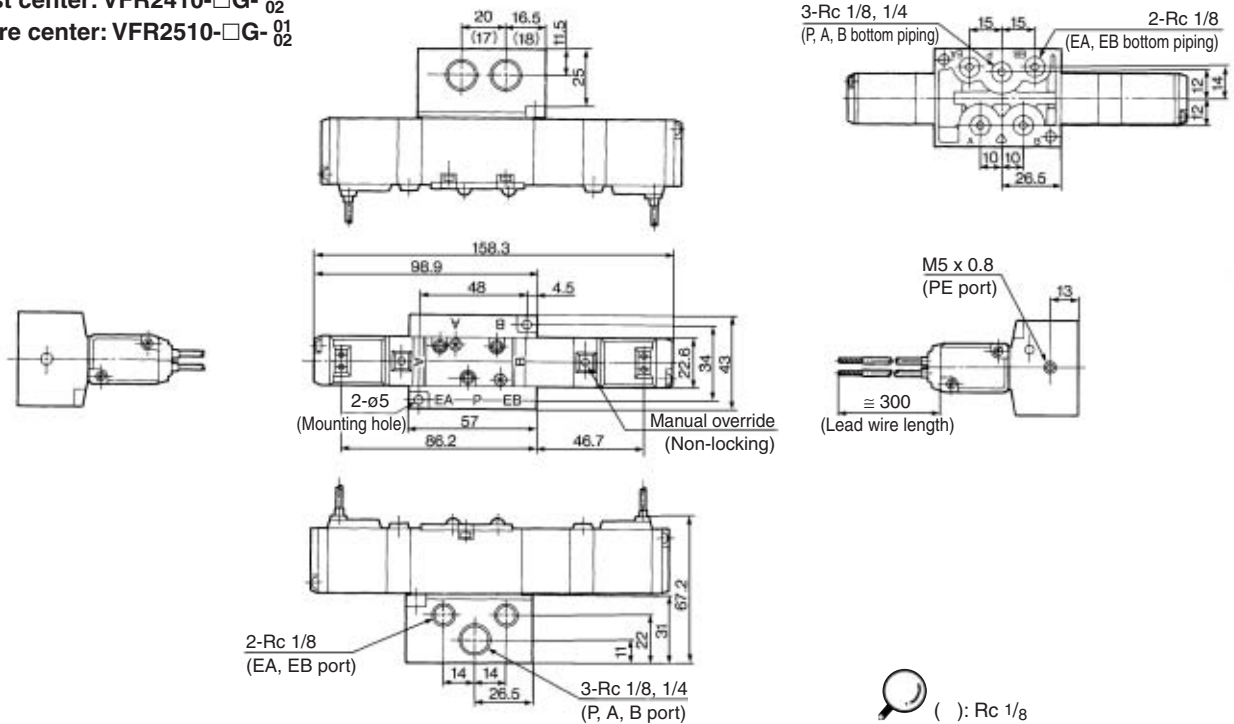

Grommet terminal

Closed center: VFR2310-□E-⁰¹/₀₂
 Exhaust center: VFR2410-□E-⁰¹/₀₂
 Pressure center: VFR2510-□E-⁰¹/₀₂

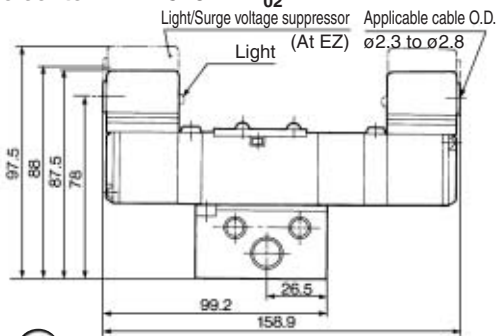

* Other dimensions are the same as the grommet type.

Conduit terminal

Closed center: VFR2310-□T-⁰¹/₀₂
 Exhaust center: VFR2410-□T-⁰¹/₀₂
 Pressure center: VFR2510-□T-⁰¹/₀₂

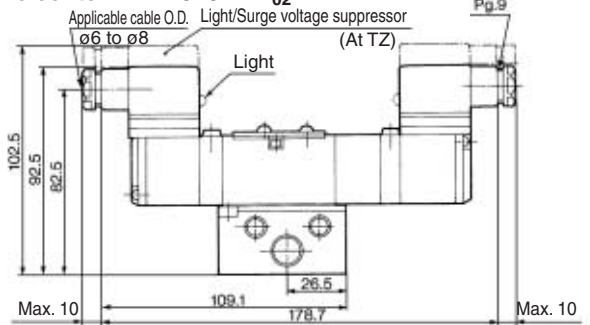

* Other dimensions are the same as the grommet type.

DIN terminal

Closed center: VFR2310-□D-⁰¹/₀₂
 Exhaust center: VFR2410-□D-⁰¹/₀₂
 Pressure center: VFR2510-□D-⁰¹/₀₂

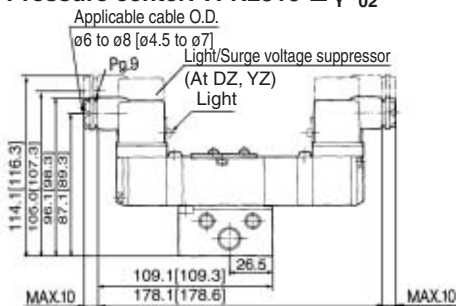

* [] : Type Y
 * Other dimensions are the same as the grommet type.

L plug connector

Closed center: VFR2310-□L-⁰¹/₀₂
 Exhaust center: VFR2410-□L-⁰¹/₀₂
 Pressure center: VFR2510-□L-⁰¹/₀₂

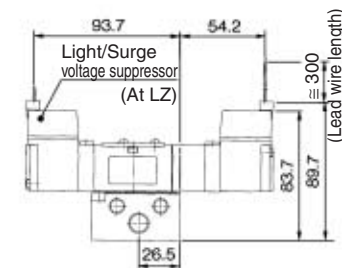

* Other dimensions are the same as the grommet type.

M plug connector

Closed center: VFR2310-□M-⁰¹/₀₂
 Exhaust center: VFR2410-□M-⁰¹/₀₂
 Pressure center: VFR2510-□M-⁰¹/₀₂

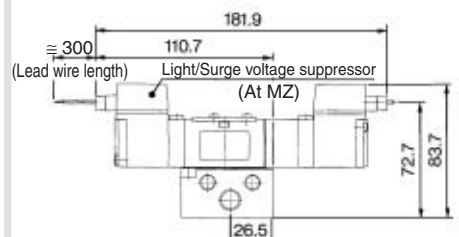

* Other dimensions are the same as the grommet type.