

Residual Pressure Relief 3 Port Hand Valve Series VHS

Series VHS is a safety manual switching valve for preventing accidents that can be caused by the residual pressure while performing maintenance service on a pneumatic system.

Easy to Operate

The direction of air flow can be verified at a glance by the orientation of the handle.

The valve is compact, yet provides a large capacity.



JIS Symbol

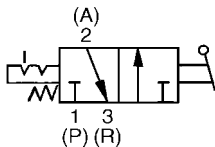

Model

Piping direction	Left IN1 (P)*	VHS400-02	VHS400-03	VHS400-04	VHS500-06
	Right IN1 (P)*	VHS401-02	VHS401-03	VHS401-04	VHS501-06
Port size		1/4	3/8	1/2	3/4
Effective area (mm ²)	1 (P) → 2 (A)	21	35	57	93
	2 (A) → 3 (R)	35	54	76	105
Weight (kg)		0.25			0.34



*Left or right to the front face of the handle.

Specifications

Fluid	Air
Operating pressure	0.1 to 1.0 MPa
Ambient temperature and operating fluid temperature	-5 to 60°C (No freezing)
Handle switching angle	90°
Required switching force	73.6 N (at 1.0 MPa)
Paint color (Standard) <small>Note</small>	Handle: Black, Body: Platinum silver



Note Handle: Silver, Body: Red (Made to order "-X1")

How to Order

VHS 4 0 0 02 Option color

Residual relief 3 port valve

Body size

4	1/2
5	3/4

Piping direction

0	Left (P)
1	Right (P)

Thread type

Nil	Rc
N	NPT
F*	G

Port size

02	1/4	
03	3/8	VHS40□
04	1/2	
06	3/4	VHS50□

Option color

Nil	Standard color
X1	Handle: Silver, Body: Red
X116	Handle: Red

* Applicable port size: 1/4, 3/8

Example of Operating Circuit

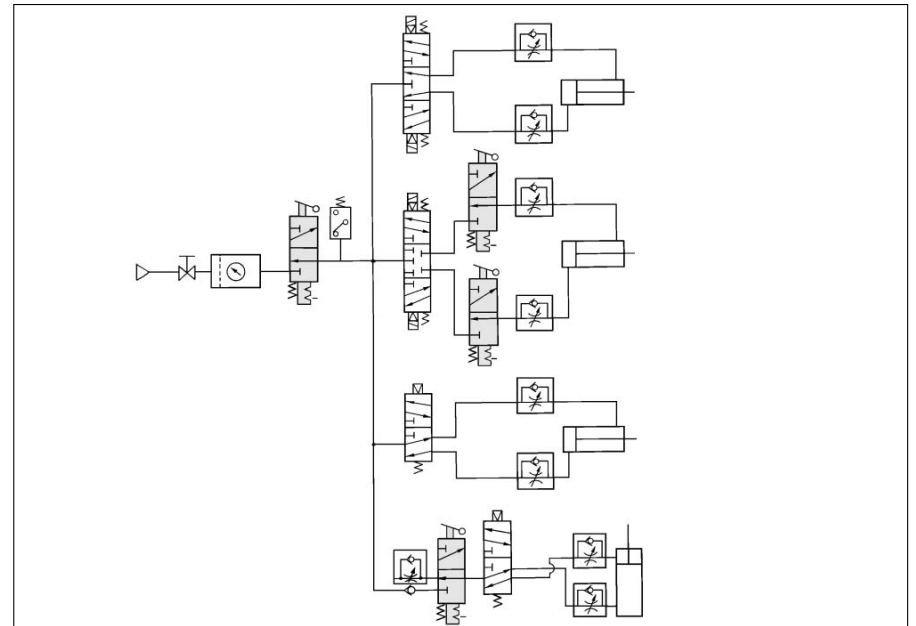

* When using the valve, please refer to the table of applicable effective areas for the respective exhaust ports.

□A

V□A

□A

V□A

VM

VR

VH

VHS

Series VHS

Construction

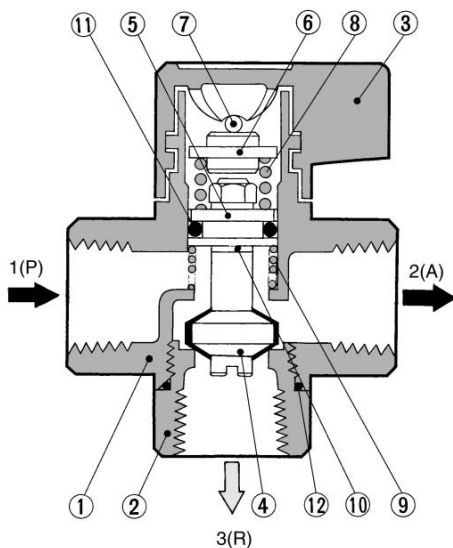

Component Parts

No.	Description	Material	Note
①	Body	Aluminium die-casted	Chromated
②	Valve guide	Zinc die-casted	Chromated
③	Handle	Zinc alloy	Chromated
④	Valve	Brass	
⑤	Piston	Brass	
⑥	Spring holder	Steel	
⑦	Parallel pin	Steel	Zinc chromated
⑧	Spring	Steel	Zinc chromated
⑨	Valve spring	Stainless steel	
⑩	Packing	PVC	
⑪	O-ring	NBR	JIS B 2401 P12.5
⑫	O-ring	NBR	Special

Dimensions

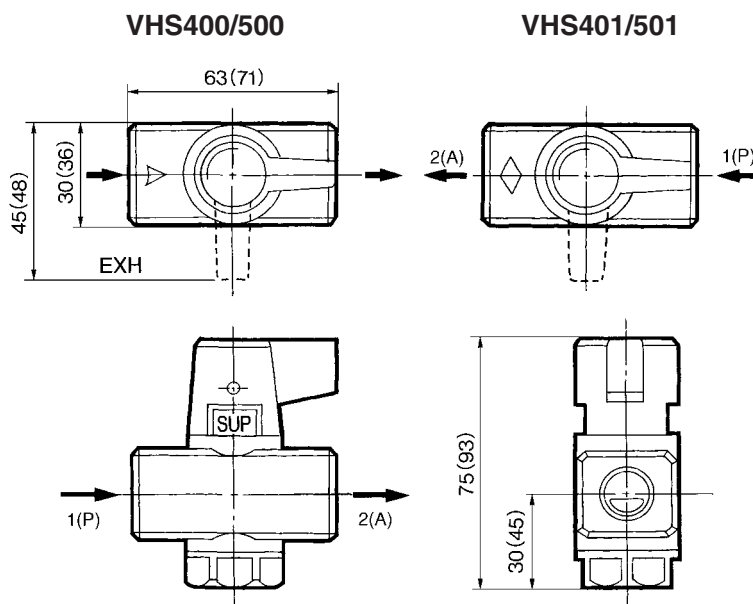

(): VHS500

⚠ Precautions

Be sure to read before handling.
Refer to pages 5-11-2 to 6 for Safety Instruction and Solenoid Valve Precautions.

Design

⚠ Warning

- When connecting the exhaust piping onto 3(R) port, confirm that the effective area is larger than the figure shown below. If the effective area is smaller than the figure listed below, back pressure will induce air leakage.

Model	Effective area (mm ²)
VHS400/401	5
VHS500/501	8

- Do not supply air pressure from ports other than 1(P) port. The valve will malfunction when air pressure is supplied from other ports.
- Do not use the valve under negative pressure.

Selection

⚠ Caution

- The valve must be switched to each position instantly and securely. Stopping the handle between the extreme positions may cause malfunction.
- Do not remove the mounting screws from the handle as this may cause malfunction.

Piping

⚠ Warning

- The port marked with an arrow is 1(P) port (IN) and one on the opposite side is 2(A) port (OUT). The port at a right angle to them is 3(R) port (EXH). Be sure to confirm before connecting since erroneous connection will cause malfunction.
- When the valve is exposed to a large amount of dust and debris, install a silencer on 3(R) port (EXH) to protect the valve. Otherwise, dust will ingress from 3(R) port and cause air leakage. When dust enters the valve from the port "3(R)", it may cause malfunction.

Air Supply

⚠ Caution

- Install an air filter on the inlet side in proximity to the valve. Filtration degree should be 5 μm or less.