

# Compact Type ZP3 Series

RoHS

Model Selection

ø1.5, ø2, ø3.5, ø4, ø6, ø8, ø10, ø13, ø16

Flat Type, Flat Type with Groove, Bellows Type, Bellows Type with Ribs

**Overall length shortened** For the flat type (Pad diameter: ø2)

ZP3 Compact

Flat Type

Flat Type with Groove

Bellows Type

Bellows Type with Ribs

Construction

Mounting Bracket Assembly

Precautions

Pad unit

**Max. 9 mm shorter**

With adapter

**Max. 11 mm shorter**

Actual size

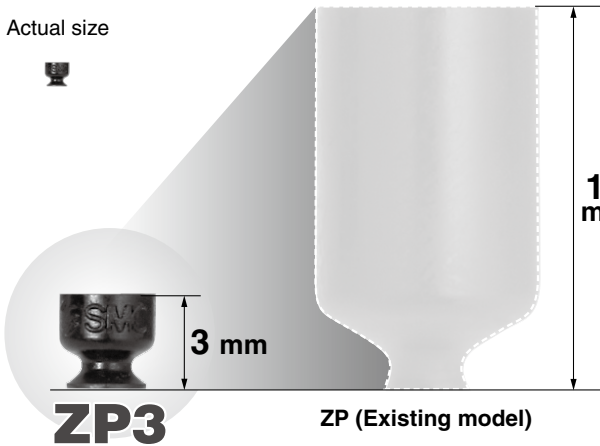

**ZP3**

ZP (Existing model)

Actual size

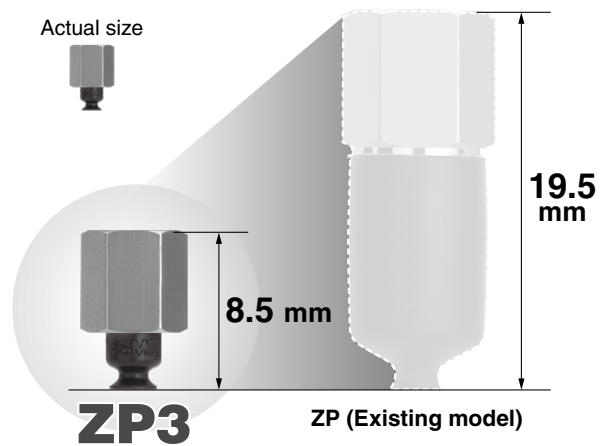

**ZP3**

ZP (Existing model)

**Space saving** ø2 piping reduces working space!

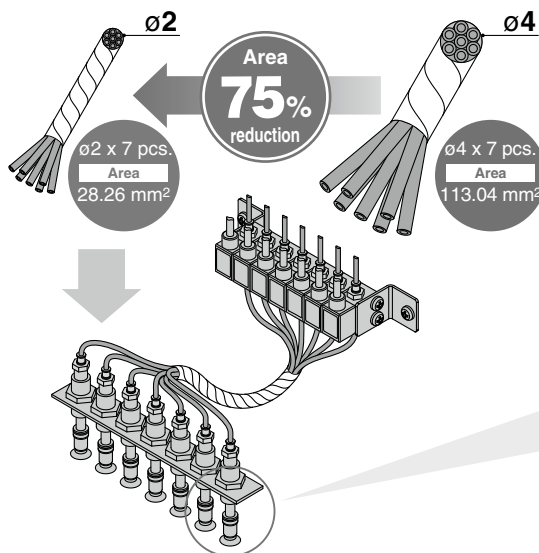

## Vertical

- Male thread
- Female thread
- Barb fitting (Applicable tubing: ø2)
- One-touch fitting (Applicable tubing: ø2)

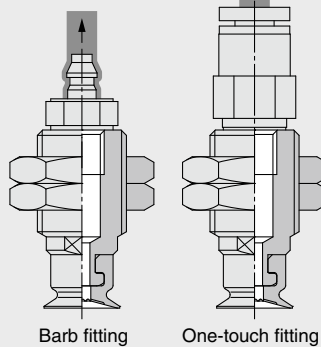

Barb fitting

One-touch fitting

## Lateral

- Female thread
- Barb fitting (Applicable tubing: ø2)
- One-touch fitting (Applicable tubing: ø2)

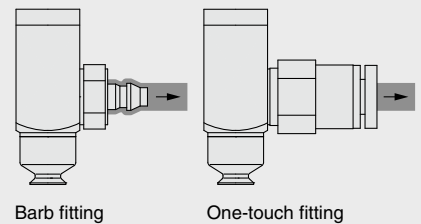

Barb fitting

One-touch fitting

## CONTENTS

### Compact Type ZP3 Series

Features.....	p. 133
Variations.....	p. 134
Specifications.....	p. 135
<b>Flat Type</b>	
· How to Order.....	p. 136
· Dimensions/Models.....	p. 137
<b>Flat Type with Groove</b>	
· How to Order.....	p. 142
· Dimensions/Models.....	p. 143

### Bellows Type

· How to Order.....	p. 148
· Dimensions/Models.....	p. 149

### Bellows Type with Ribs

· How to Order.....	p. 154
· Dimensions/Models.....	p. 155
Construction.....	p. 160
Mounting Bracket Assembly.....	p. 162
Specific Product Precautions.....	p. 165



## Improved functions

### Improved removability

Adsorption surface is shot-blasted

Micro-dents and bumps on the surface facilitate easy removal.

With groove

Less contact surface with the workpiece makes it easy to remove.



### Construction to prevent the pad from coming off

The new shape of the part which connects with the adapter prevents the pad from coming off.

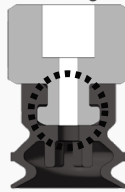

Pad diameter from  $\phi 1.5$

### Easier identification

SMC logo mark



### Fixing boss which allows for easy mounting and repeatability

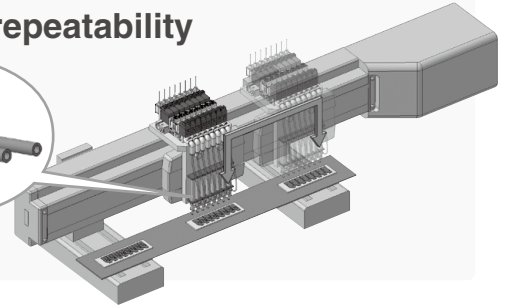
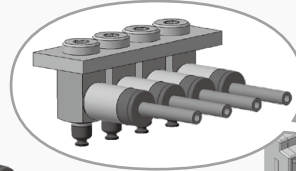
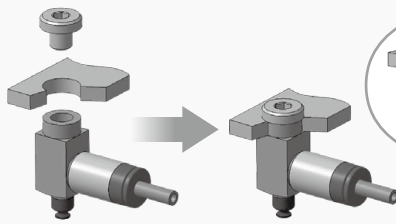

## Compact buffer body

### Overall length shortened

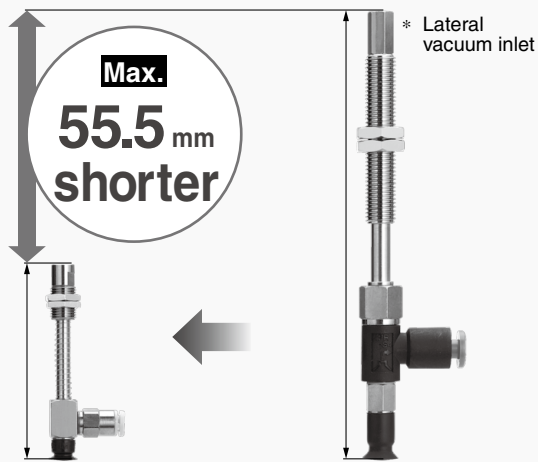

ZP3

ZP

Pad diameter  $\phi 8$ , Flat type, With One-touch fitting

ZP3

Stroke	Overall length [mm]
3	40
6	46
10	56
15	59
20	66.5
25	—

ZP

Stroke	Overall length [mm]
3	—
6	78.5
10	109.5
15	114.5
20	—
25	124.5

### Short stroke type: 3 mm available

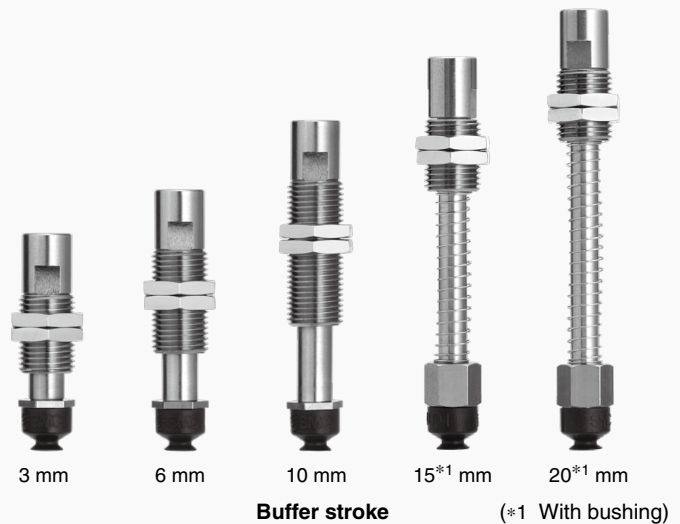

Buffer stroke

(\*1 With bushing)

Pad diameter	Buffer specifications	Stroke [mm]				
		3	6	10	15	20
$\phi 1.5, \phi 2, \phi 3.5$	Rotating, Non-rotating	●	●	—	—	—
	Rotating	●	●	●	—	—
$\phi 4, \phi 6, \phi 8, \phi 10, \phi 13, \phi 16$	Rotating, With bushing	—	—	—	●	●
	Non-rotating	●	●	●	●	●

## Wide selection of piping

Male thread

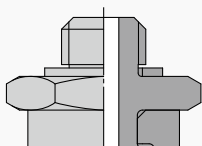

Female thread

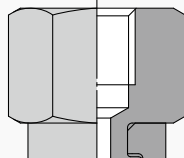





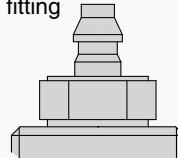

For  $\phi 2$  piping!

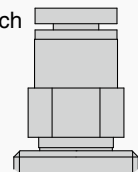
Barb fitting

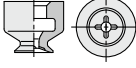

One-touch fitting

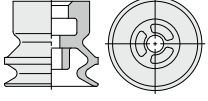

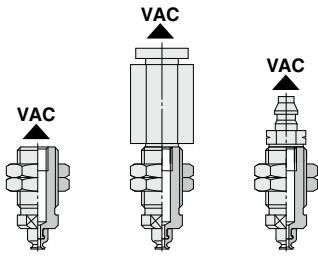
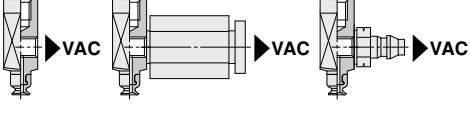
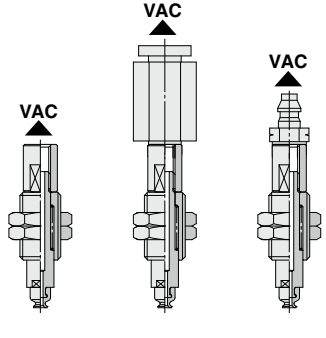
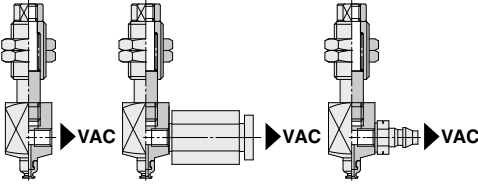
		Vacuum inlet direction									
		Flat type	Flat type with groove	Bellows type	Bellows type with ribs						
Vacuum inlet direction	Single unit					p. 137	p. 143	p. 149	p. 155		
	Vertical	ZP3-T With adapter					p. 137	p. 143	p. 149	p. 155	
		ZP3-T With adapter					p. 138	p. 144	p. 150	p. 156	
		Lateral	ZP3-Y With adapter					p. 139	p. 145	p. 151	p. 157
			ZP3-T With buffer					p. 140	p. 146	p. 152	p. 158
	Lateral	ZP3-Y With buffer					p. 141	p. 147	p. 153	p. 159	

Model Selection

ZP3 Compact

Flat Type

Flat Type with Groove

Bellows Type

Bellows Type with Ribs

Construction

Mounting Bracket Assembly

Precautions

# Compact Type *ZP3 Series* Specifications

## Pad Material

Material	NBR (Nitrile rubber)	Silicone rubber *1*2	Urethane rubber	FKM (Fluoro rubber)	Conductive NBR (Nitrile rubber)	Conductive silicone rubber	Semiconductive silicone rubber	Semiconductive HNBR
Color of rubber	Black	White	Navy blue	Black				Blue
Rubber hardness (Shore A: ±5°)	60		50	60	60 to 70	60	55	60

\*1 Uses a material compliant with a dissolution test of the FDA (U.S. Food and Drug Administration) regulation 21CFR§177.2600 for "Rubber articles intended for repeated use."

\*2 Uses a material compliant with the standards for "Rubber apparatus (excluding baby drinking apparatus) and containers/packaging" (D3) (Partial revision: Japanese Ministry of Health, Labour, and Welfare Notification No. 595, 2012) in Section 3 "Apparatus and Containers/Packaging" of the Japan Food Sanitation Act, Article 18 "Specifications and Standards for Food and Food Additives, etc." (Japanese Ministry of Health and Welfare Notification No. 370, 1959)

## Adapter Specifications

### Vacuum Inlet Direction **Vertical** T Type/ZP3-T

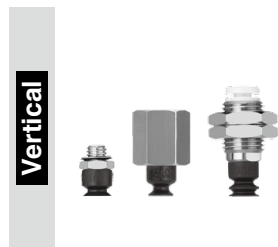

Connection		Male thread					Female thread		
Pad diameter		ø1.5 to ø3.5		ø4 to ø8		ø10 to ø16		ø1.5 to ø3.5 ø4 to ø16	
Connection thread		M3 x 0.5	M6 x 0.75	M5 x 0.8	M10 x 1	M5 x 0.8	M12 x 1	M3 x 0.5	M5 x 0.8
Vacuum inlet	Female thread	Use the connection thread.	M3 x 0.5	Use the connection thread.	M5 x 0.8	Use the connection thread.	M5 x 0.8	Use the connection thread.	Use the connection thread.
	One-touch fitting		ø2, ø4		ø2, ø4		ø2, ø4, ø6		
	Barb fitting*1		ø2, ø4		ø2, ø4		ø2, ø4, ø6		

\*1 ø2 polyurethane tubing, ø4, ø6 soft tubing

### Vacuum Inlet Direction **Lateral** Y Type/ZP3-Y

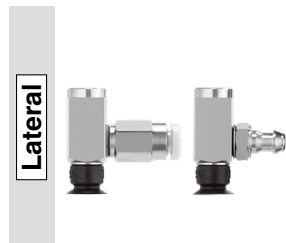

Connection		Female thread		
Pad diameter		ø1.5 to ø3.5	ø4 to ø8	ø10 to ø16
Connection thread		M3 x 0.5	M5 x 0.8	M5 x 0.8
Vacuum inlet	Female thread	M3 x 0.5	M5 x 0.8	M5 x 0.8
	One-touch fitting	ø2, ø4	ø2, ø4	ø2, ø4, ø6
	Barb fitting*1	ø2, ø4	ø2, ø4	ø2, ø4, ø6

\*1 ø2 polyurethane tubing, ø4, ø6 soft tubing

## Buffer Specifications

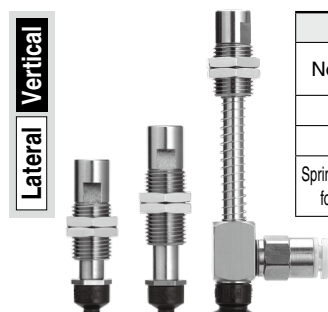

Pad diameter		ø1.5 to ø3.5		ø4 to ø16		
Non-rotating specification		J: Rotating	K: Non-rotating	J: Rotating	JB: Rotating, With bushing	K: Non-rotating
Stroke [mm]		3, 6		3, 6, 10	15, 20	3, 6, 10, 15, 20
Connection thread		M6 x 0.75	M8 x 0.75	M8 x 0.75		
Spring reactive force [N]	At 0 stroke	0.2		0.2		
	At full stroke	0.4	0.5	0.5		



**Dimensions/Models**

Single unit  $\varnothing 1.5$  to  $\varnothing 3.5$

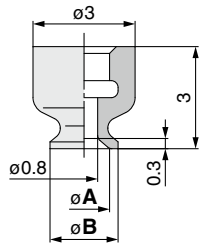

Construction p. 160

Mounting Bracket Assembly From p. 162

ZP3 - **015** U **N**  
① ②

Model	① Pad dia.	Form	② Material <sup>*1</sup>	A		B	
ZP3	015	U	N S U F GN GS	1.5		2	
	02			2		2.5	
	035			3.5		4	

\*1 N: NBR, S: Silicone rubber, U: Urethane rubber, F: FKM, GN: Conductive NBR, GS: Conductive silicone rubber

With adapter  $\varnothing 1.5$  to  $\varnothing 3.5$

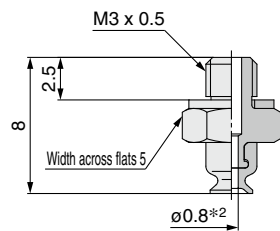

Construction p. 160

Adapter Assembly p. 162

ZP3 **□** - T **015** U **N** - **A3**  
① ② ③ ④

① Adapter material

Nil	Brass
S	Stainless steel (Stainless steel 304)

④ Connection thread (Male thread)

A3	M3 x 0.5
----	----------

Model	① Adapter material	Vacuum inlet direction	② Pad dia.	Form	③ Material <sup>*1</sup>	④ Connection thread

\*1 N: NBR, S: Silicone rubber, U: Urethane rubber, F: FKM, GN: Conductive NBR, GS: Conductive silicone rubber

\*2 Indicates the minimum hole size of the adapter or vacuum pad

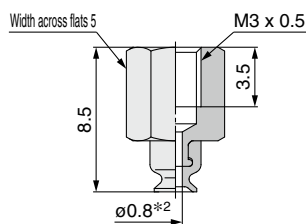

Construction p. 160

Adapter Assembly p. 162

ZP3 **□** - T **015** U **N** - **B3**  
① ② ③ ④

① Adapter material

Nil	Brass
S	Stainless steel (Stainless steel 304)

④ Connection thread (Female thread)

B3	M3 x 0.5
----	----------

Model	① Adapter material	Vacuum inlet direction	② Pad dia.	Form	③ Material <sup>*1</sup>	④ Connection thread

\*1 N: NBR, S: Silicone rubber, U: Urethane rubber, F: FKM, GN: Conductive NBR, GS: Conductive silicone rubber

\*2 Indicates the minimum hole size of the adapter or vacuum pad

**Dimensions/Models**

**With adapter**  $\varnothing 1.5$  to  $\varnothing 3.5$

ZP3   - T 015 U N - A6 - B3

1   
 2   
 3   
 4   
 5

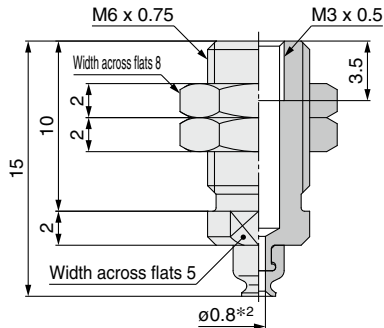

**1 Adapter material**

<b>Nil</b>	Brass
<b>S</b>	Stainless steel (Stainless steel 304)

**4 Connection thread (Male thread)**

<b>A6</b>	M6 x 0.75
-----------	-----------

**5 Vacuum inlet**

<b>B3</b>	M3 x 0.5	Female thread
<b>02</b>	$\varnothing 2$	One-touch fitting*1
<b>04</b>	$\varnothing 4$	
<b>U2</b>	For $\varnothing 2$ polyurethane tubing	Barb fitting*1
<b>U4</b>	For $\varnothing 4$ soft tubing	

\*1 Not compatible with stainless steel materials

**Vacuum inlet: One-touch fitting**

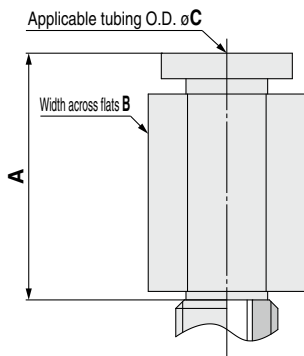

**Vacuum inlet: Barb fitting**

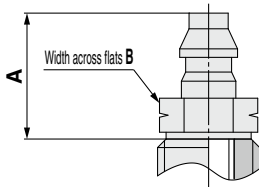

**Construction** p. 160

**Adapter Assembly** p. 163

	Model						
	1 Adapter material	Vacuum inlet direction	2 Pad dia.	Form	3 Material*1	4 Connection thread	5 Vacuum inlet
ZP3	Nil S	T	015 02 035	U	N S U F GN GS	A6	B3

**Dimensions Per Vacuum Inlet: One-touch Fitting**

	Model						A	B	C	Fitting part min. hole size	Fitting part no.
	1 Adapter material	Vacuum inlet direction	2 Pad dia.	Form	3 Material*1	4 Connection thread					
ZP3	Nil	T	015 02 035	U	N S U F GN GS	A6			$\varnothing 1.2$	02	KQ2H02-M3G
										04	KQ2H04-M3G

**Dimensions Per Vacuum Inlet: Barb Fitting**

	Model						A	B	Fitting part min. hole size	Fitting part no.
	1 Adapter material	Vacuum inlet direction	2 Pad dia.	Form	3 Material*1	4 Connection thread				
ZP3	Nil	T	015 02 035	U	N S U F GN GS	A6			U2	M-3AU-2
									U4	M-3AU-4-X83

\*1 N: NBR, S: Silicone rubber, U: Urethane rubber, F: FKM, GN: Conductive NBR, GS: Conductive silicone rubber

\*2 Indicates the minimum hole size of the adapter or vacuum pad

**Dimensions/Models**

**With adapter**  $\varnothing 1.5$  to  $\varnothing 3.5$

ZP3   - Y 015 U N - B3 - B3

1    
 2    
 3    
 4    
 5

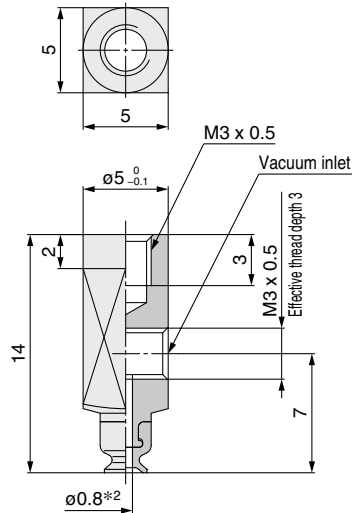

**Vacuum inlet: One-touch fitting**

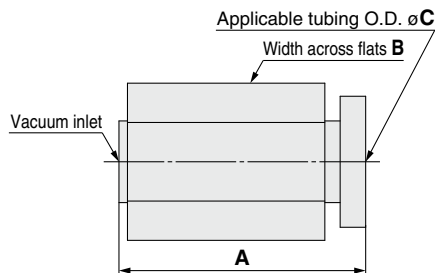

**Vacuum inlet: Barb fitting**

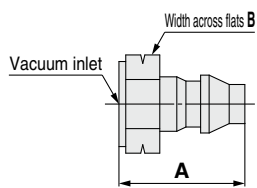

**Construction** p. 160

**Adapter Assembly** p. 162

**1 Adapter material**

<b>Nil</b>	Brass
<b>S</b>	Stainless steel (Stainless steel 304)

**4 Connection thread (Female thread)**

<b>B3</b>	M3 x 0.5
-----------	----------

**5 Vacuum inlet**

<b>B3</b>	M3 x 0.5	Female thread
<b>02</b>	$\varnothing 2$	One-touch fitting*1
<b>04</b>	$\varnothing 4$	
<b>U2</b>	For $\varnothing 2$ polyurethane tubing	Barb fitting*1
<b>U4</b>	For $\varnothing 4$ soft tubing	

\*1 Not compatible with stainless steel materials

	Model						
	1 Adapter material	Vacuum inlet direction	2 Pad dia.	Form	3 Material*1	4 Connection thread	5 Vacuum inlet
ZP3	Nil S	Y	015 02 035	U	N S U F GN GS	B3	B3

**Dimensions Per Vacuum Inlet: One-touch Fitting**

	Model						A	B	C	Fitting part min. hole size	Fitting part no.			
	1 Adapter material	Vacuum inlet direction	2 Pad dia.	Form	3 Material*1	4 Connection thread						5 Vacuum inlet		
ZP3	Nil	Y	015 02 035	U	N S U F GN GS	B3			$\varnothing 1.2$	02	13	5.5	2	KQ2H02-M3G
										04	14.5	8	4	KQ2H04-M3G

**Dimensions Per Vacuum Inlet: Barb Fitting**

	Model						A	B	Fitting part min. hole size	Fitting part no.				
	1 Adapter material	Vacuum inlet direction	2 Pad dia.	Form	3 Material*1	4 Connection thread					5 Vacuum inlet			
ZP3	Nil	Y	015 02 035	U	N S U F GN GS	B3			$\varnothing 0.9$	U2	6.5	4.5		M-3AU-2
										U4	7.4	5		M-3AU-4-X83

\*1 N: NBR, S: Silicone rubber, U: Urethane rubber, F: FKM, GN: Conductive NBR, GS: Conductive silicone rubber

\*2 Indicates the minimum hole size of the adapter or vacuum pad

**Dimensions/Models**

**With buffer**  $\varnothing 1.5$  to  $\varnothing 3.5$

**ZP3 - T 015 U N J 3 - B3**

① ② ③ ④ ⑤

⑤ Vacuum inlet

**Buffer specification** ③

<b>J</b>	Rotating
<b>K</b>	Non-rotating

<b>B3</b>	M3 x 0.5	Female thread
<b>02</b>	$\varnothing 2$	One-touch fitting
<b>04</b>	$\varnothing 4$	One-touch fitting
<b>U2</b>	For $\varnothing 2$ polyurethane tubing	Barb fitting
<b>U4</b>	For $\varnothing 4$ soft tubing	

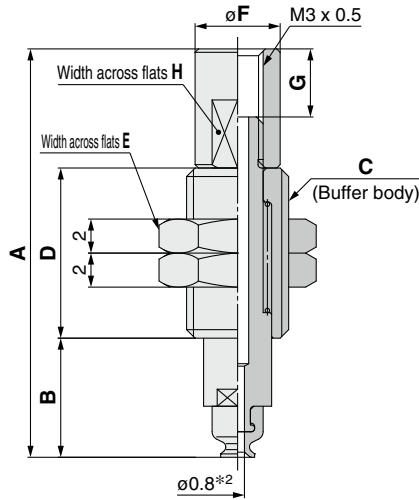

		Model					A	B	C	D	E	F	G	H
Vacuum inlet direction	① Pad dia.	Form	② <sup>*1</sup> Material	③ Buffer spec.	④ Buffer stroke	⑤ Vacuum inlet								
ZP3	T	015 02 035	U	N S U F GN GS	J	3	24	7	M6 x 0.75	10	8	5	4	4
						6								
					K	3	26.5	8	M8 x 0.75	11	10	7	3	6
						6								

**Dimensions Per Vacuum Inlet: One-touch Fitting**

		Model					J	K	L	Fitting part min. hole size	Fitting part no.
Vacuum inlet direction	① Pad dia.	Form	② <sup>*1</sup> Material	③ Buffer spec.	④ Buffer stroke	⑤ Vacuum inlet					
ZP3	T	015 02 035	U	N S U F GN GS	J K	3 6	13	5.5	2	$\varnothing 1.2$	KQ2H02-M3G
											04

**Dimensions Per Vacuum Inlet: Barb Fitting**

		Model					J	K	Fitting part min. hole size	Fitting part no.
Vacuum inlet direction	① Pad dia.	Form	② <sup>*1</sup> Material	③ Buffer spec.	④ Buffer stroke	⑤ Vacuum inlet				
ZP3	T	015 02 035	U	N S U F GN GS	J K	3 6	6.5	4.5	$\varnothing 0.9$	M-3AU-2
										U4

\*1 N: NBR, S: Silicone rubber, U: Urethane rubber, F: FKM, GN: Conductive NBR, GS: Conductive silicone rubber

\*2 Indicates the minimum hole size of the adapter or vacuum pad

**Vacuum inlet: One-touch fitting**

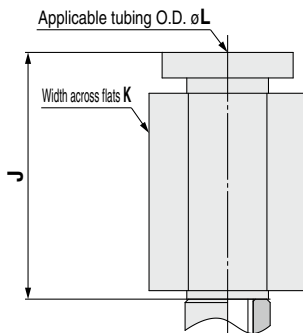

**Vacuum inlet: Barb fitting**

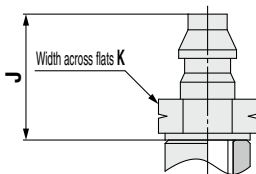

<b>Construction</b>	p. 161
<b>Buffer Assembly</b>	p. 164

**Dimensions/Models**

**With buffer**  $\varnothing 1.5$  to  $\varnothing 3.5$

**ZP3 - Y 015 U N J 3 - B3**

①

②

④

⑤ Vacuum inlet

**Buffer specification** ③

<b>J</b>	Rotating
<b>K</b>	Non-rotating

<b>B3</b>	M3 x 0.5	Female thread
<b>02</b>	$\varnothing 2$	One-touch fitting
<b>04</b>	$\varnothing 4$	One-touch fitting
<b>U2</b>	For $\varnothing 2$ polyurethane tubing	Barb fitting
<b>U4</b>	For $\varnothing 4$ soft tubing	

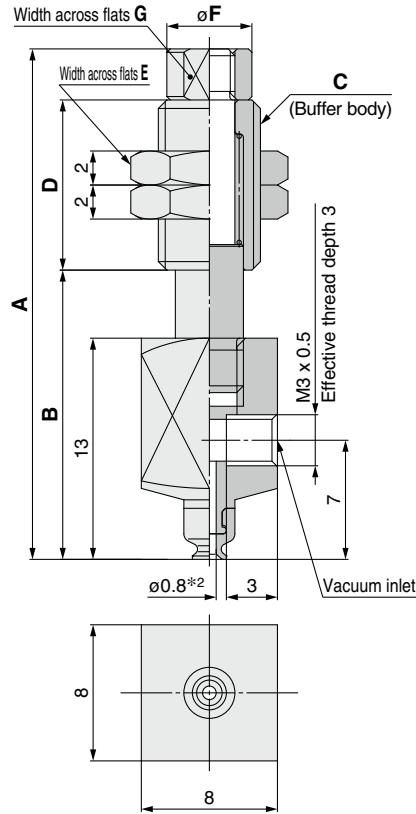

		Model					A	B	C	D	E	F	G	
	Vacuum inlet direction	① Pad dia.	Form	② <sup>*1</sup> Material	③ Buffer spec.	④ Buffer stroke	⑤ Vacuum inlet							
ZP3	Y	015 02 035	U	N S U F GN GS	J	3	B3	30	17	M6 x 0.75	10	8	5	4
						6		37	20		14			
					K	3	34	17	M8 x 0.75	11	10	7	6	
						6	40.5	20		14.5				

**Dimensions Per Vacuum Inlet: One-touch Fitting**

		Model					H	J	K	Fitting part min. hole size	Fitting part no.	
	Vacuum inlet direction	① Pad dia.	Form	② <sup>*1</sup> Material	③ Buffer spec.	④ Buffer stroke	⑤ Vacuum inlet					
ZP3	Y	015 02 035	U	N S U F GN GS	J K	3 6	02	13	5.5	2	$\varnothing 1.2$	KQ2H02-M3G
							04	14.5	8	4		KQ2H04-M3G

**Dimensions Per Vacuum Inlet: Barb Fitting**

		Model					H	J	Fitting part min. hole size	Fitting part no.	
	Vacuum inlet direction	① Pad dia.	Form	② <sup>*1</sup> Material	③ Buffer spec.	④ Buffer stroke	⑤ Vacuum inlet				
ZP3	Y	015 02 035	U	N S U F GN GS	J K	3 6	U2	6.5	4.5	$\varnothing 0.9$	M-3AU-2
							U4	7.4	5	$\varnothing 1.2$	M-3AU-4-X83

\*1 N: NBR, S: Silicone rubber, U: Urethane rubber, F: FKM, GN: Conductive NBR, GS: Conductive silicone rubber

\*2 Indicates the minimum hole size of the adapter or vacuum pad

**Vacuum inlet: One-touch fitting**

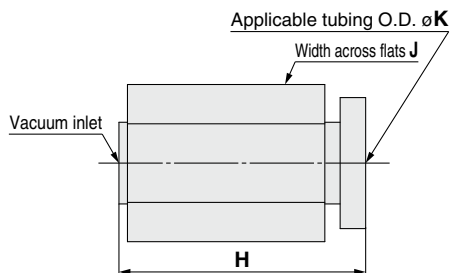

**Vacuum inlet: Barb fitting**

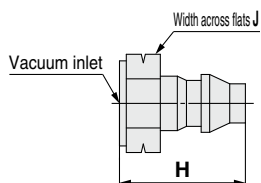

<b>Construction</b>	p. 161
<b>Buffer Assembly</b>	p. 164



# Compact Type Flat Type with Groove

## ZP3 Series

Pad diameter:  $\varnothing 4, \varnothing 6, \varnothing 8, \varnothing 10, \varnothing 13, \varnothing 16$



Model Selection

### How to Order

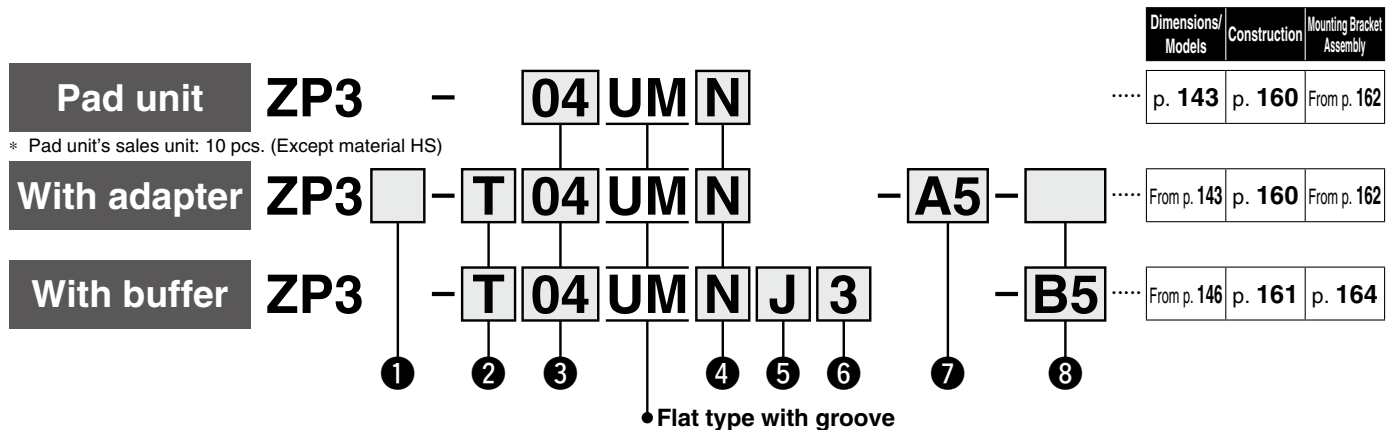

#### ① Adapter material

<b>Nil</b>	Brass
<b>S*1</b>	Stainless steel (Stainless steel 304)

\*1 Only applicable to the pad with adapter

#### ② Vacuum inlet direction

<b>Nil</b>	Pad unit
<b>T</b>	Vertical
<b>Y</b>	Lateral

#### ③ Pad diameter

<b>04</b>	$\varnothing 4$
<b>06</b>	$\varnothing 6$
<b>08</b>	$\varnothing 8$
<b>10</b>	$\varnothing 10$
<b>13</b>	$\varnothing 13$
<b>16</b>	$\varnothing 16$

#### ④ Material

<b>N</b>	NBR
<b>S</b>	Silicone rubber*1*2
<b>U</b>	Urethane rubber
<b>F</b>	FKM
<b>GN</b>	Conductive NBR
<b>GS</b>	Conductive silicone rubber
<b>HS</b>	Semiconductive silicone rubber
<b>HNN</b>	Semiconductive HNBR

\*1 Uses a material compliant with a dissolution test of the FDA (U.S. Food and Drug Administration) regulation 21CFR§177.2600 for "Rubber articles intended for repeated use."

\*2 Uses a material compliant with the standards for "Rubber apparatus (excluding baby drinking apparatus) and containers/packaging" (D3) (Partial revision: Japanese Ministry of Health, Labour, and Welfare Notification No. 595, 2012) in Section 3 "Apparatus and Containers/Packaging" of the Japan Food Sanitation Act, Article 18 "Specifications and Standards for Food and Food Additives, etc." (Japanese Ministry of Health and Welfare Notification No. 370, 1959)

#### ⑤ Buffer specification

<b>J</b>	Rotating
<b>JB</b>	Rotating, With bushing
<b>K</b>	Non-rotating

#### ⑥ Buffer stroke

Stroke [mm]	Buffer specification		
	J	JB	K
<b>3</b>	●	—	●
<b>6</b>	●	—	●
<b>10</b>	●	—	●
<b>15</b>	—	●	●
<b>20</b>	—	●	●

### With adapter

#### ⑦ Connection thread/ ⑧ Vacuum inlet ○: ZP3□-T/Vertical ●: ZP3□-Y/Lateral

Type	⑦ Connection thread		⑧ Vacuum inlet		Pad diameter [mm]		
	Symbol	Size	Symbol	Size	$\varnothing 4$ to $\varnothing 8$	$\varnothing 10$ to $\varnothing 16$	
Male thread	<b>A5</b>	M5 x 0.8	—	<b>Nil</b>	Use the connection thread.	○ ○	
			Female thread	<b>B5</b>	M5 x 0.8	○ ○	
				One-touch fitting	<b>02*3</b>	$\varnothing 2$	○ —
					<b>04</b>	$\varnothing 4$	○ —
			Barb fitting*3	<b>U2</b>	For $\varnothing 2$ polyurethane tubing*1	○ —	
				<b>U4</b>	For $\varnothing 4$ soft tubing*2	○ —	
	<b>A10</b>	M10 x 1		Female thread	<b>B5</b>	M5 x 0.8	— ○
			One-touch fitting		<b>02*3</b>	$\varnothing 2$	— ○
					<b>04</b>	$\varnothing 4$	— ○
			Barb fitting*3	<b>06</b>	$\varnothing 6$	— ○	
				<b>U2</b>	For $\varnothing 2$ polyurethane tubing*1	— ○	
				<b>U4</b>	For $\varnothing 4$ soft tubing*2	— ○	
<b>A12</b>	M12 x 1	Female thread	<b>B5</b>	M5 x 0.8	— ○		
			One-touch fitting	<b>02*3</b>	$\varnothing 2$	— ○	
				<b>04</b>	$\varnothing 4$	— ○	
		Barb fitting*3	<b>06</b>	$\varnothing 6$	— ○		
			<b>U2</b>	For $\varnothing 2$ polyurethane tubing*1	— ○		
			<b>U4</b>	For $\varnothing 4$ soft tubing*2	— ○		
Female thread	<b>B5</b>	M5 x 0.8	—	<b>Nil</b>	Use the connection thread.	○ ○	
			Female thread	<b>B5</b>	M5 x 0.8	● ●	
				One-touch fitting*3	<b>02</b>	$\varnothing 2$	● ●
					<b>04</b>	$\varnothing 4$	● ●
			Barb fitting*3	<b>06</b>	$\varnothing 6$	— ●	
				<b>U2</b>	For $\varnothing 2$ polyurethane tubing*1	● ●	
<b>U4</b>	For $\varnothing 4$ soft tubing*2	● ●					
Barb fitting*3	<b>U6</b>	For $\varnothing 6$ soft tubing*2	— ●				

### With buffer

#### ⑧ Vacuum inlet ○: ZP3-T/Vertical ●: ZP3-Y/Lateral

Type	Symbol	Size	Pad diameter [mm]	
			$\varnothing 4$ to $\varnothing 8$	$\varnothing 10$ to $\varnothing 16$
Female thread	<b>B5</b>	M5 x 0.8	○ ●	○ ●
One-touch fitting	<b>02</b>	$\varnothing 2$	○ ●	○ ●
	<b>04</b>	$\varnothing 4$	○ ●	○ ●
	<b>06</b>	$\varnothing 6$	—	○ ●
Barb fitting	<b>U2</b>	For $\varnothing 2$ polyurethane tubing*1	○ ●	○ ●
	<b>U4</b>	For $\varnothing 4$ soft tubing*2	○ ●	○ ●
	<b>U6</b>	For $\varnothing 6$ soft tubing*2	—	○ ●

\*1 Polyurethane tube piping

\*2 Soft nylon/Polyurethane tube piping

\*3 Not compatible with stainless steel materials

\* It is not necessary to select a connection thread.

\* The pad, mounting nut, and fitting are shipped together but do not come assembled.

ZP3 Compact

Flat Type

Flat Type with Groove

Bellows Type

Bellows Type with Ribs

Construction

Mounting Bracket Assembly

Precautions

## Dimensions/Models

### Single unit $\phi 4$ to $\phi 16$

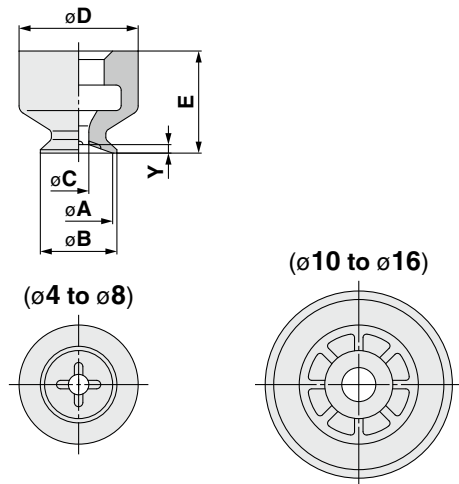

### ZP3 - **04** UM **N**

①      ②

Model				A	B	C	D	E	Y
① Pad dia.	Form	② Material <sup>*1</sup>							
ZP3	04	UM	N S U F GN GS HS HHN	4	4.5	1.2	7	6	0.5
	06			6	6.5				0.8
	08			8	8.5				0.8
	10			10	11	2	9	7	1
	13			13	14				1.2
	16			16	17				1.2

\*1 N: NBR, S: Silicone rubber, U: Urethane rubber, F: FKM, GN: Conductive NBR, GS: Conductive silicone rubber, HS: Semiconductive silicone rubber, HHN: Semiconductive HNBR

Construction p. 160

Mounting Bracket Assembly From p. 162

### With adapter $\phi 4$ to $\phi 16$

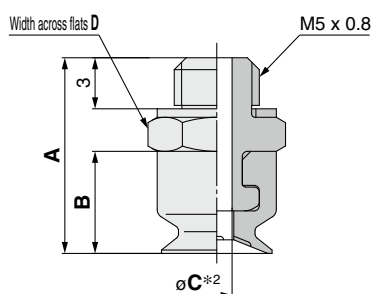

Construction p. 160

Adapter Assembly p. 162

### ZP3 - T **04** UM **N** - **A5**

①      ②      ③      ④

① Adapter material	④ Connection thread (Male thread)
Nil Brass	A5 M5 x 0.8
S Stainless steel (Stainless steel 304)	

Model						A	B	C*2	D		
① Adapter material	Vacuum inlet direction	② Pad dia.	Form	③ Material <sup>*1</sup>	④ Connection thread						
ZP3	Nil S	T	UM	N S U F GN GS HS HHN	A5	11.5	6	1.2	7		
									10	1.8	10
									13	1.8	10
						16	12.5	7	1.8	10	

\*1 N: NBR, S: Silicone rubber, U: Urethane rubber, F: FKM, GN: Conductive NBR, GS: Conductive silicone rubber, HS: Semiconductive silicone rubber, HHN: Semiconductive HNBR  
\*2 Indicates the minimum hole size of the adapter or vacuum pad

### With adapter $\phi 4$ to $\phi 16$

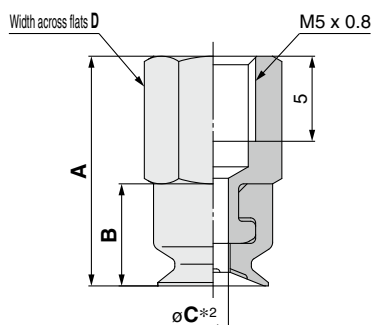

Construction p. 160

Adapter Assembly p. 162

### ZP3 - T **04** UM **N** - **B5**

①      ②      ③      ④

① Adapter material	④ Connection thread (Female thread)
Nil Brass	B5 M5 x 0.8
S Stainless steel (Stainless steel 304)	

Model						A	B	C*2	D		
① Adapter material	Vacuum inlet direction	② Pad dia.	Form	③ Material <sup>*1</sup>	④ Connection thread						
ZP3	Nil S	T	UM	N S U F GN GS HS HHN	B5	13.5	6	1.2	7		
									10	1.8	10
									13	1.8	10
						16	14.5	7	1.8	10	

\*1 N: NBR, S: Silicone rubber, U: Urethane rubber, F: FKM, GN: Conductive NBR, GS: Conductive silicone rubber, HS: Semiconductive silicone rubber, HHN: Semiconductive HNBR  
\*2 Indicates the minimum hole size of the adapter or vacuum pad

**Dimensions/Models**

**With adapter  $\phi 4$  to  $\phi 16$**

Pad diameter:  $\phi 4$  to  $\phi 6$

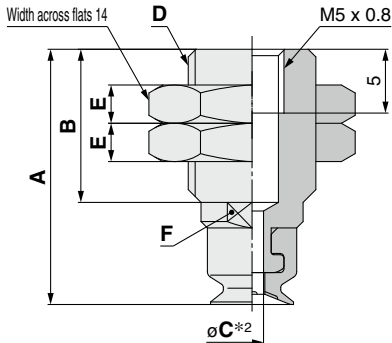

Pad diameter:  $\phi 10$  to  $\phi 16$

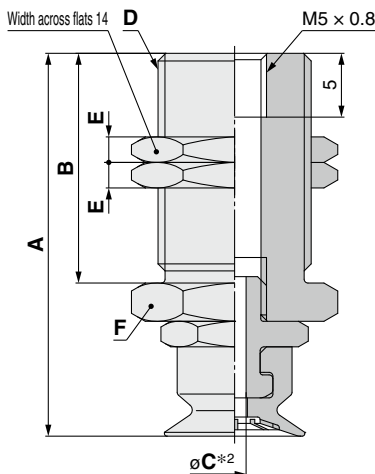

Vacuum inlet: One-touch fitting ( $\phi 2$ )

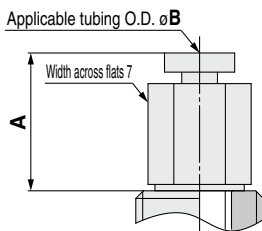

Vacuum inlet: Built-in One-touch fitting ( $\phi 4$ ,  $\phi 6$ )

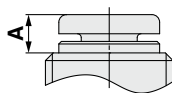

Vacuum inlet: Barb fitting

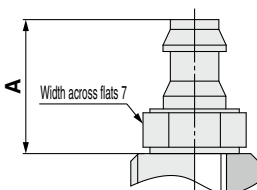

ZP3   - T 04 UM N - A10 - B5

①                      ②                      ③                      ④                      ⑤

① Adapter material

Nil	Brass
S	Stainless steel (Stainless steel 304)

④ Connection thread (Male thread)

A10	M10 x 1
A12	M12 x 1

⑤ Vacuum inlet

B5	M5 x 0.8	Female thread
02	$\phi 2$	One-touch fitting
04	$\phi 4$	
06	$\phi 6$	
U2*1	For $\phi 2$ polyurethane tubing	Barb fitting
U4*1	For $\phi 4$ soft tubing	
U6*1	For $\phi 6$ soft tubing	

\*1 Not compatible with stainless steel materials

Model	① Adapter material	Vacuum inlet direction	② Pad dia.	Form	③ Material*1	④ Connection thread	⑤ Vacuum inlet	A	B	C*2	D	E	F
								ZP3	Nil S	T	04	UM	N S F GN GS HS HHN
06	30	18	1.8	M12 x 1	2	Width across flats 14							
10													
13 16													

**Dimensions Per Vacuum Inlet: One-touch Fitting**

Model	① Adapter material	Vacuum inlet direction	② Pad dia.	Form	③ Material*1	④ Connection thread	⑤ Vacuum inlet	A	B	Fitting part min. hole size	Fitting part no.
ZP3	Nil S	T	04	UM	N S F GN GS HS HHN	A10	02*3	10.8	2	$\phi 1.4$	KQ2H02-M5N
			06				3	4	$\phi 1.8$	KQ2H02-M5N	
			10				10.8	2	$\phi 1.4$		
			13				3	4	$\phi 1.8$		
			16				02	10.8	2	$\phi 1.4$	
			06				3.2	6	$\phi 1.8$		

\*3 Not compatible with stainless steel materials

**Dimensions Per Vacuum Inlet: Barb Fitting**

Model	① Adapter material	Vacuum inlet direction	② Pad dia.	Form	③ Material*1	④ Connection thread	⑤ Vacuum inlet	A	Fitting part min. hole size	Fitting part no.
ZP3	Nil	T	04	UM	N S F GN GS HS HHN	A10	U2	6.5	$\phi 0.9$	M-5AU-2
			06				8.5	$\phi 1.8$	M-5AU-4	
			08				6.5	$\phi 0.9$	M-5AU-2	
			10				8.5	$\phi 1.8$	M-5AU-4	
			13				10.5	$\phi 2.5$	M-5AU-6	
			16				U6	10.5	$\phi 2.5$	M-5AU-6

\*1 N: NBR, S: Silicone rubber, U: Urethane rubber, F: FKM, GN: Conductive NBR, GS: Conductive silicone rubber, HS: Semiconductive silicone rubber, HHN: Semiconductive HNBR  
\*2 Indicates the minimum hole size of the adapter or vacuum pad

## Dimensions/Models

With adapter  $\phi 4$  to  $\phi 16$

ZP3   - Y 04 UM N - B5 - B5  
① ② ③ ④ ⑤

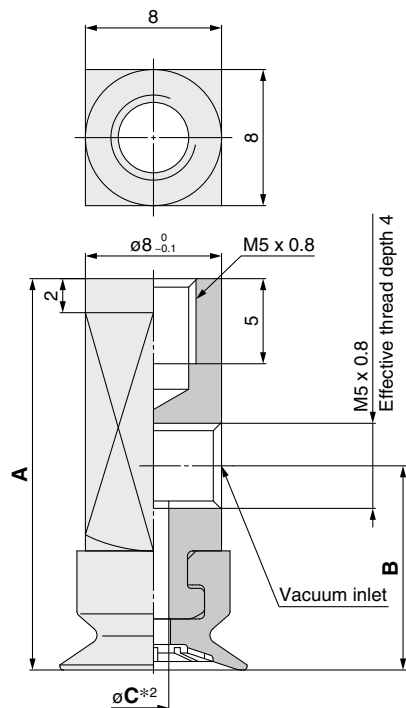

### ① Adapter material

Nil	Brass
S	Stainless steel (Stainless steel 304)

### ④ Connection thread (Female thread)

B5	M5 x 0.8
----	----------

### ⑤ Vacuum inlet

B5	M5 x 0.8	Female thread
02	$\phi 2$	One-touch fitting*1
04	$\phi 4$	
06	$\phi 6$	
U2	For $\phi 2$ polyurethane tubing	Barb fitting*1
U4	For $\phi 4$ soft tubing	
U6	For $\phi 6$ soft tubing	

\*1 Not compatible with stainless steel materials

	Model						A	B	C*2	
	① Adapter material	Vacuum inlet direction	② Pad dia.	Form	③ Material*1	④ Connection thread				⑤ Vacuum inlet
ZP3	Nil S	Y	04	UM	N S U F GN GS HS HHN	B5	B5	22	11	1.2
			06							2
			08							
			10 13 16							

### Vacuum inlet: One-touch fitting

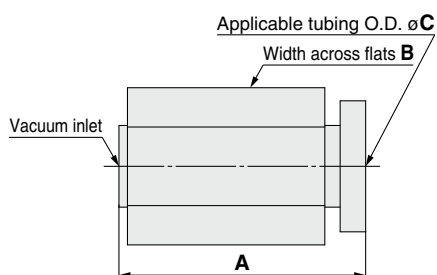

### Vacuum inlet: Barb fitting

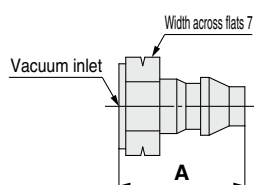

Construction p. 160

Adapter Assembly p. 162

### Dimensions Per Vacuum Inlet: One-touch Fitting

	Model						A	B	C	Fitting part min. hole size	Fitting part no.	
	① Adapter material	Vacuum inlet direction	② Pad dia.	Form	③ Material*1	④ Connection thread						⑤ Vacuum inlet
ZP3	Nil	Y	04	UM	N S U F GN GS HS HHN	B5	02	10.8	7	2	$\phi 1.4$	KQ2H02-M5N
			06				14.7	8	4	$\phi 2.5$	KQ2H04-M5N	
			08				10.8	7	2	$\phi 1.4$	KQ2H02-M5N	
			10				14.7	8	4	$\phi 2.5$	KQ2H04-M5N	
			13					10	6		KQ2H06-M5N	
			16									

### Dimensions Per Vacuum Inlet: Barb Fitting

	Model						A	Fitting part min. hole size	Fitting part no.	
	① Adapter material	Vacuum inlet direction	② Pad dia.	Form	③ Material*1	④ Connection thread				⑤ Vacuum inlet
ZP3	Nil	Y	04	UM	N S U F GN GS HS HHN	B5	U2	6.5	$\phi 0.9$	M-5AU-2
			06				U4	8.5	$\phi 1.8$	M-5AU-4
			08				U2	6.5	$\phi 0.9$	M-5AU-2
			10				U4	8.5	$\phi 1.8$	M-5AU-4
			13				U6	10.5	$\phi 2.5$	M-5AU-6
			16							

\*1 N: NBR, S: Silicone rubber, U: Urethane rubber, F: FKM, GN: Conductive NBR, GS: Conductive silicone rubber, HS: Semiconductive silicone rubber, HHN: Semiconductive HNBR

\*2 Indicates the minimum hole size of the adapter or vacuum pad

Dimensions/Models

With buffer  $\varnothing 4$  to  $\varnothing 16$

ZP3 - T **04** **UM** **N** **J** **3** - **B5**

① ② ③ ④ ⑤

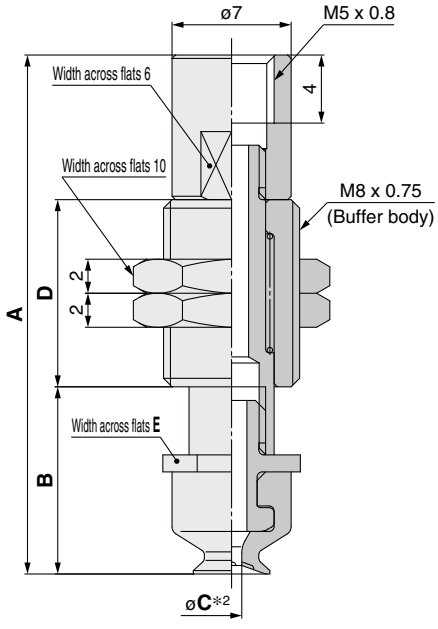

Buffer specification ③

<b>J</b>	Rotating
<b>JB</b>	Rotating, With bushing
<b>K</b>	Non-rotating

⑤ Vacuum inlet

<b>B5</b>	M5 x 0.8	Female thread
<b>02</b>	$\varnothing 2$	One-touch fitting
<b>04</b>	$\varnothing 4$	
<b>06</b>	$\varnothing 6$	
<b>U2</b>	For $\varnothing 2$ polyurethane tubing	
<b>U4</b>	For $\varnothing 4$ soft tubing	
<b>U6</b>	For $\varnothing 6$ soft tubing	

Vacuum inlet: One-touch fitting

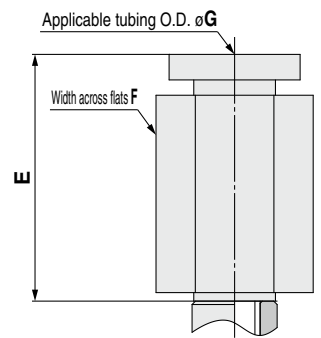

Vacuum inlet: Barb fitting

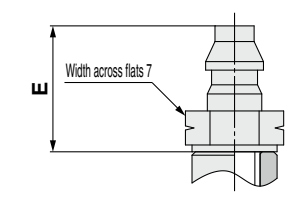

Construction p. 161  
Buffer Assembly p. 164

		Model					A	B	C*2	D	E				
Vacuum inlet direction	① Pad dia.	Form	②*1 Material	③ Buffer spec.	④ Buffer stroke	⑤ Vacuum inlet									
ZP3	T	04	UM	N S U F GN GS HS HHN	J K	3	B5	30.5	11	1.2	11	7			
						6		37	14		14.5				
						10		47	18		20.5				
		06 08			JB K	3		30.5	11	11					
						6		37	14	14.5					
						10		47	18	20.5					
	10 13 16	JB K	15 20	15 20	3	55	36.5	1.2	10						
					6	62.5	44			14.5					
					10	55	36.5			20.5					
					15 20	J K	3 6	31.5		12	1.8	11			
												6	38	15	14.5
												10	48	19	20.5
15 20	JB K	15 20	56	37.5	10	10									
						63.5	45								

Dimensions Per Vacuum Inlet: One-touch Fitting

		Model					E	F	G	Fitting part min. hole size	Fitting part no.	
Vacuum inlet direction	① Pad dia.	Form	②*1 Material	③ Buffer spec.	④ Buffer stroke	⑤ Vacuum inlet						
ZP3	T	04 06 08	UM	N S U F GN GS HS HHN	J JB K	3	02	10.8	7	2	$\varnothing 1.4$	KQ2H02-M5N
						6	04	14.7	8	4	$\varnothing 2.5$	KQ2H04-M5N
						10	02	10.8	7	2	$\varnothing 1.4$	KQ2H02-M5N
		13 16			04 06	15 20	04	14.7	8	4	$\varnothing 2.5$	KQ2H04-M5N
							06	14.7	10	6	$\varnothing 2.5$	KQ2H06-M5N

Dimensions Per Vacuum Inlet: Barb Fitting

		Model					E	Fitting part min. hole size	Fitting part no.	
Vacuum inlet direction	① Pad dia.	Form	②*1 Material	③ Buffer spec.	④ Buffer stroke	⑤ Vacuum inlet				
ZP3	T	04 06 08	UM	N S U F GN GS HS HHN	J JB K	3	U2	6.5	$\varnothing 0.9$	M-5AU-2
						6	U4	8.5	$\varnothing 1.8$	M-5AU-4
						10	U2	6.5	$\varnothing 0.9$	M-5AU-2
		13 16			U4 U6	15 20	U4	8.5	$\varnothing 1.8$	M-5AU-4
							U6	10.5	$\varnothing 2.5$	M-5AU-6

\*1 N: NBR, S: Silicone rubber, U: Urethane rubber, F: FKM, GN: Conductive NBR, GS: Conductive silicone rubber, HS: Semiconductive silicone rubber, HHN: Semiconductive HNBR  
\*2 Indicates the minimum hole size of the adapter or vacuum pad

## Dimensions/Models

With buffer  $\varnothing 4$  to  $\varnothing 16$

ZP3 - Y **04** **UM** **N** **J** **3** - **B5**

① ② ③ ④ ⑤ Vacuum inlet

Buffer specification ③

<b>J</b>	Rotating
<b>JB</b>	Rotating, With bushing
<b>K</b>	Non-rotating

<b>B5</b>	M5 x 0.8	Female thread
<b>02</b>	$\varnothing 2$	One-touch fitting
<b>04</b>	$\varnothing 4$	
<b>06</b>	$\varnothing 6$	
<b>U2</b>	For $\varnothing 2$ polyurethane tubing	Barb fitting
<b>U4</b>	For $\varnothing 4$ soft tubing	
<b>U6</b>	For $\varnothing 6$ soft tubing	

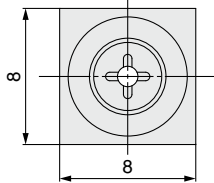
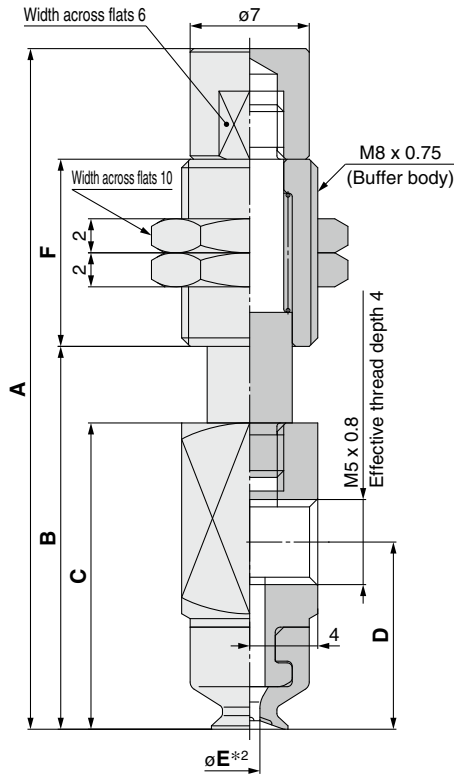

### Vacuum inlet: One-touch fitting

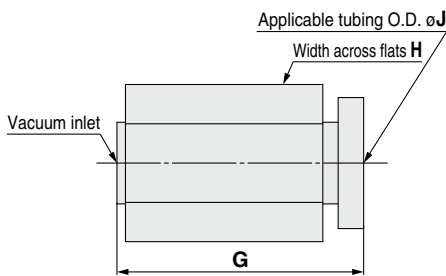

### Vacuum inlet: Barb fitting

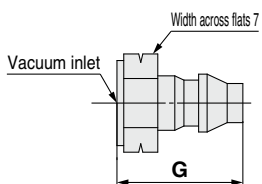

		Model					A	B	C	D	E*2	F
Vacuum inlet direction	① Pad dia.	② Form	③ Material	④ Buffer spec.	⑤ Buffer stroke							
ZP3	Y	04	UM	N S U F GN GS HS HHN	J K	3	40	22.5	18	11	1.2	11
						6	46	25				14.5
		10			56	29	20.5					
		06 08			JB K	3	40	22.5				11
						6	46	25				14.5
		10			56	29	20.5					
	04	JB K	15	59	42.5	1.8	10					
			20	66.5	50							
	06 08	JB K	15	59	42.5			1.2	10			
			20	66.5	50							
	10 13 16	J K	3	41	23.5					1.8	11	
			6	47	26							14.5
10	57	30	20.5									
13	JB K	15	60	43.5	1.8	10						
		20	67.5	57								

### Dimensions Per Vacuum Inlet: One-touch Fitting

		Model					G	H	J	Fitting part min. hole size	Fitting part no.	
Vacuum inlet direction	① Pad dia.	② Form	③ Material	④ Buffer spec.	⑤ Buffer stroke							
ZP3	Y	04 06 08	UM	N S U F GN GS HS HHN	J K	3	02	10.8	7	2	$\varnothing 1.4$	KQ2H02-M5N
						6	04	14.7	8	4	$\varnothing 2.5$	KQ2H04-M5N
		10 13 16			JB K	15	02	10.8	7	2	$\varnothing 1.4$	KQ2H02-M5N
						20	04	14.7	8	4	$\varnothing 2.5$	KQ2H04-M5N
		06			JB K	15	04	14.7	8	4	$\varnothing 2.5$	KQ2H06-M5N
						20	06	14.7	10	6	$\varnothing 2.5$	KQ2H06-M5N

### Dimensions Per Vacuum Inlet: Barb Fitting

		Model					G	Fitting part min. hole size	Fitting part no.	
Vacuum inlet direction	① Pad dia.	② Form	③ Material	④ Buffer spec.	⑤ Buffer stroke					
ZP3	Y	04 06 08	UM	N S U F GN GS HS HHN	J K	3	U2	6.5	$\varnothing 0.9$	M-5AU-2
						6	U4	8.5	$\varnothing 1.8$	M-5AU-4
		10 13 16			JB K	10	U2	6.5	$\varnothing 0.9$	M-5AU-2
						15	U4	8.5	$\varnothing 1.8$	M-5AU-4
		06			JB K	20	U4	8.5	$\varnothing 1.8$	M-5AU-4
						20	U6	10.5	$\varnothing 2.5$	M-5AU-6

\*1 N: NBR, S: Silicone rubber, U: Urethane rubber, F: FKM, GN: Conductive NBR, GS: Conductive silicone rubber, HS: Semiconductive silicone rubber, HHN: Semiconductive HNBR

\*2 Indicates the minimum hole size of the adapter or vacuum pad



# Compact Type

## Bellows Type

# ZP3 Series

Pad diameter:  $\varnothing 4$ ,  $\varnothing 6$ ,  $\varnothing 8$

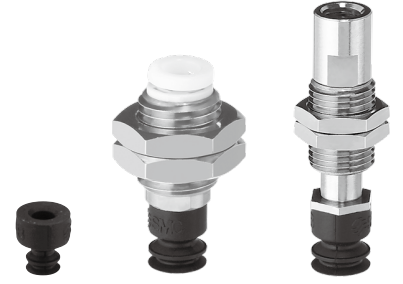

Model Selection

ZP3 Compact

Flat Type

Flat Type with Groove

Bellows Type

Bellows Type with Ribs

Construction

Mounting Bracket Assembly

Precautions

### How to Order

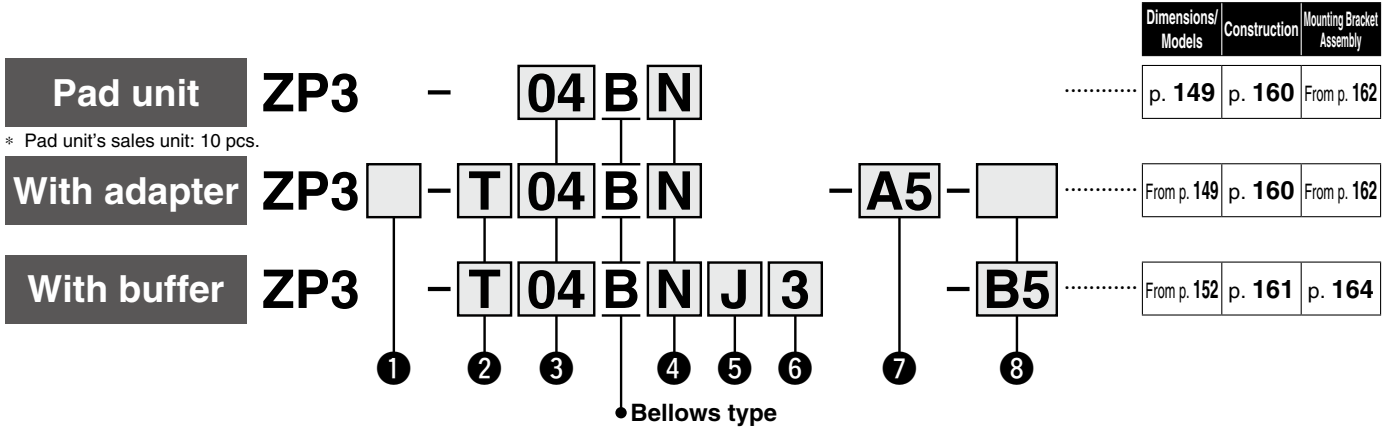

#### ① Adapter material

Nil	Brass
S*1	Stainless steel (Stainless steel 304)

\*1 Only applicable to the pad with adapter

#### ② Vacuum inlet direction

Nil	Pad unit
T	Vertical
Y	Lateral

#### ③ Pad diameter

04	$\varnothing 4$
06	$\varnothing 6$
08	$\varnothing 8$

#### ④ Material

N	NBR
S	Silicone rubber*1 *2
U	Urethane rubber
F	FKM
GN	Conductive NBR
GS	Conductive silicone rubber

\*1 Uses a material compliant with a dissolution test of the FDA (U.S. Food and Drug Administration) regulation 21CFR§177.2600 for "Rubber articles intended for repeated use."

\*2 Uses a material compliant with the standards for "Rubber apparatus (excluding baby drinking apparatus) and containers/packaging" (D3) (Partial revision: Japanese Ministry of Health, Labour, and Welfare Notification No. 595, 2012) in Section 3 "Apparatus and Containers/Packaging" of the Japan Food Sanitation Act, Article 18 "Specifications and Standards for Food and Food Additives, etc." (Japanese Ministry of Health and Welfare Notification No. 370, 1959)

#### ⑤ Buffer specification

J	Rotating
JB	Rotating, With bushing
K	Non-rotating

#### ⑥ Buffer stroke

Stroke [mm]	Buffer specification		
	J	JB	K
3	●	—	●
6	●	—	●
10	●	—	●
15	—	●	●
20	—	●	●

### With adapter

#### ⑦ Connection thread/⑧ Vacuum inlet

○: ZP3□-T/Vertical ●: ZP3□-Y/Lateral

⑦ Connection thread			⑧ Vacuum inlet		Pad diameter
Type	Symbol	Size	Type	Symbol	Size
Male thread	A5	M5 x 0.8	—	Nil	Use the connection thread.
			Female thread	B5	M5 x 0.8
	A10	M10 x 1	One-touch fitting	02*3	$\varnothing 2$
			Barb fitting*3	04	$\varnothing 4$
				U2	For $\varnothing 2$ polyurethane tubing
Female thread	B5	M5 x 0.8	—	Nil	Use the connection thread.
			Female thread	B5	M5 x 0.8
	One-touch fitting*3	02	$\varnothing 2$		
		04	$\varnothing 4$		
		U2	For $\varnothing 2$ polyurethane tubing*1		
Barb fitting*3	U4	For $\varnothing 4$ soft tubing*2			

\*1 Polyurethane tube piping  
\*2 Soft nylon/Polyurethane tube piping  
\*3 Not compatible with stainless steel materials

### With buffer

#### ⑧ Vacuum inlet

○: ZP3-T/Vertical ●: ZP3-Y/Lateral

Type	Symbol	Size	Pad diameter
Female thread	B5	M5 x 0.8	○●
One-touch fitting	02	$\varnothing 2$	○●
	04	$\varnothing 4$	○●
Barb fitting	U2	For $\varnothing 2$ polyurethane tubing*1	○●
	U4	For $\varnothing 4$ soft tubing*2	○●

\* It is not necessary to select a connection thread.

\* The pad, mounting nut, and fitting are shipped together but do not come assembled.

## Dimensions/Models

### Single unit $\varnothing 4$ to $\varnothing 8$

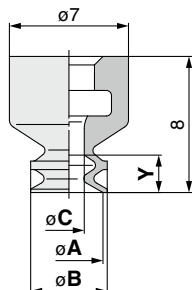

Construction p. 160

Mounting Bracket Assembly From p. 162

### ZP3 - **04** **B** **N**

① ②

Model				A	B	C	Y	
① Pad dia.	Form	② Material <sup>*1</sup>						
ZP3	04	B	N		4	4.5	1.8	2.2
	06		S		6	7	2	3
	08		U F GN GS		8	9		

\*1 N: NBR, S: Silicone rubber, U: Urethane rubber, F: FKM, GN: Conductive NBR, GS: Conductive silicone rubber

### With adapter $\varnothing 4$ to $\varnothing 8$

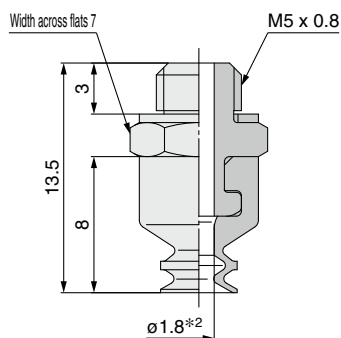

Construction p. 160

Adapter Assembly p. 162

### ZP3 **T** **04** **B** **N** - **A5**

① ② ③ ④

#### ① Adapter material

Nil	Brass
S	Stainless steel (Stainless steel 304)

#### ④ Connection thread (Male thread)

A5	M5 x 0.8
----	----------

Model						
ZP3	① Adapter material	Vacuum inlet direction	② Pad dia.	Form	③ Material <sup>*1</sup>	④ Connection thread
		Nil S	T	04 06 08	B	N S U F GN GS

\*1 N: NBR, S: Silicone rubber, U: Urethane rubber, F: FKM, GN: Conductive NBR, GS: Conductive silicone rubber

\*2 Indicates the minimum hole size of the adapter or vacuum pad

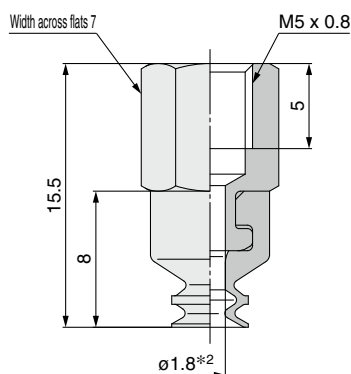

Construction p. 160

Adapter Assembly p. 162

### ZP3 **T** **04** **B** **N** - **B5**

① ② ③ ④

#### ① Adapter material

Nil	Brass
S	Stainless steel (Stainless steel 304)

#### ④ Connection thread (Female thread)

B5	M5 x 0.8
----	----------

Model						
ZP3	① Adapter material	Vacuum inlet direction	② Pad dia.	Form	③ Material <sup>*1</sup>	④ Connection thread
		Nil S	T	04 06 08	B	N S U F GN GS

\*1 N: NBR, S: Silicone rubber, U: Urethane rubber, F: FKM, GN: Conductive NBR, GS: Conductive silicone rubber

\*2 Indicates the minimum hole size of the adapter or vacuum pad

Dimensions/Models

**With adapter**  $\varnothing 4$  to  $\varnothing 8$

ZP3   - T 04 B N - A10 - B5

1   
 2   
 3   
 4   
 5

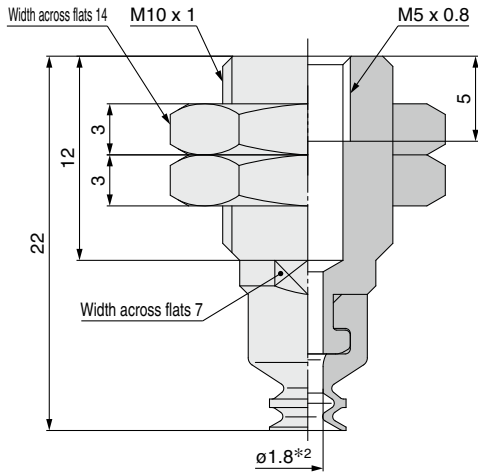

**1 Adapter material**

<b>Nil</b>	Brass
<b>S</b>	Stainless steel (Stainless steel 304)

**4 Connection thread (Female thread)**

<b>A10</b>	M10 x 1
------------	---------

**5 Vacuum inlet**

<b>B5</b>	M5 x 0.8	Female thread
<b>02</b> <sup>*1</sup>	$\varnothing 2$	One-touch fitting
<b>04</b>	$\varnothing 4$	Barb fitting
<b>U2</b> <sup>*1</sup>	For $\varnothing 2$ polyurethane tubing	
<b>U4</b> <sup>*1</sup>	For $\varnothing 4$ soft tubing	

\*1 Not compatible with stainless steel materials

	Model						
	<b>1</b> Adapter material	Vacuum inlet direction	<b>2</b> Pad dia.	Form	<b>3</b> Material <sup>*1</sup>	<b>4</b> Connection thread	<b>5</b> Vacuum inlet
ZP3	Nil S	T	04 06 08	B	N S U F GN GS	A10	B5

**Vacuum inlet: One-touch fitting ( $\varnothing 2$ )**

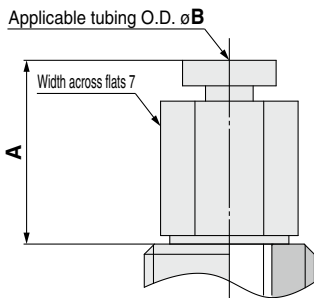

**Vacuum inlet: Built-in One-touch fitting ( $\varnothing 4$ )**

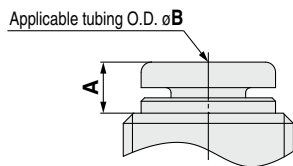

**Vacuum inlet: Barb fitting**

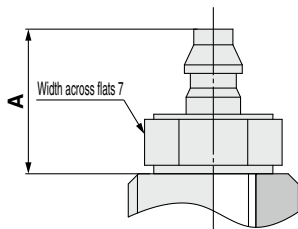

**Dimensions Per Vacuum Inlet: One-touch Fitting**

	Model						A	B	Fitting part min. hole size	Fitting part no.	
	<b>1</b> Adapter material	Vacuum inlet direction	<b>2</b> Pad dia.	Form	<b>3</b> Material <sup>*1</sup>	<b>4</b> Connection thread					<b>5</b> Vacuum inlet
ZP3	Nil S	T	04 06 08	B	N S U F GN GS	A10	02 <sup>*3</sup>	10.8	2	$\varnothing 1.4$	KQ2H02-M5N
							04	3	4	$\varnothing 1.8$	

\*3 Not compatible with stainless steel materials

**Dimensions Per Vacuum Inlet: Barb Fitting**

	Model						A	Fitting part min. hole size	Fitting part no.	
	<b>1</b> Adapter material	Vacuum inlet direction	<b>2</b> Pad dia.	Form	<b>3</b> Material <sup>*1</sup>	<b>4</b> Connection thread				<b>5</b> Vacuum inlet
ZP3	Nil	T	04 06 08	B	N S U F GN GS	A10	U2	6.5	$\varnothing 0.9$	M-5AU-2
							U4	8.5	$\varnothing 1.8$	M-5AU-4

\*1 N: NBR, S: Silicone rubber, U: Urethane rubber, F: FKM, GN: Conductive NBR, GS: Conductive silicone rubber

\*2 Indicates the minimum hole size of the adapter or vacuum pad

Construction	p. 160
Adapter Assembly	p. 163

## Dimensions/Models

With adapter  $\varnothing 4$  to  $\varnothing 8$

ZP3   - Y 04 B N - B5 - B5  
①      ②      ③      ④      ⑤

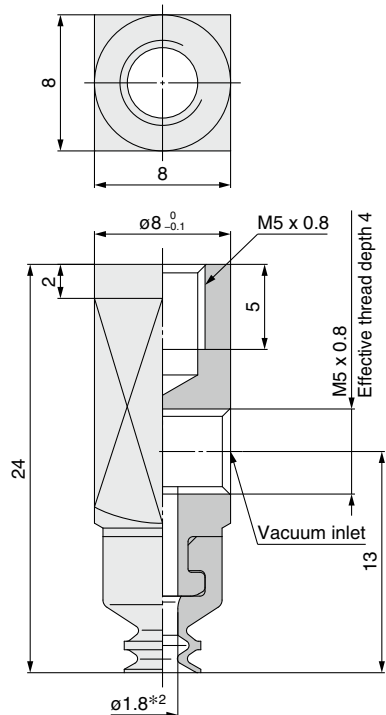

### Vacuum inlet: One-touch fitting

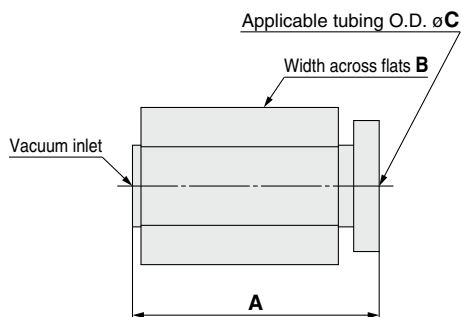

### Vacuum inlet: Barb fitting

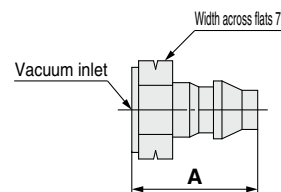

Construction	p. 160
Adapter Assembly	p. 162

### ④ Connection thread (Female thread)

<b>B5</b>	M5 x 0.8
-----------	----------

### ⑤ Vacuum inlet

<b>B5</b>	M5 x 0.8	Female thread
<b>02</b>	$\varnothing 2$	One-touch fitting*1
<b>04</b>	$\varnothing 4$	Barb fitting*1
<b>U2</b>	For $\varnothing 2$ polyurethane tubing	Barb fitting*1
<b>U4</b>	For $\varnothing 4$ soft tubing	Barb fitting*1

\*1 Not compatible with stainless steel materials

	Model						
	① Adapter material	Vacuum inlet direction	② Pad dia.	Form	③ Material*1	④ Connection thread	⑤ Vacuum inlet
ZP3	Nil S	Y	04 06 08	B	N S U F GN GS	B5	B5

### Dimensions Per Vacuum Inlet: One-touch Fitting

	Model						A	B	C	Fitting part min. hole size	Fitting part no.	
	① Adapter material	Vacuum inlet direction	② Pad dia.	Form	③ Material*1	④ Connection thread						⑤ Vacuum inlet
ZP3	Nil	Y	04 06 08	B	N S U F GN GS	B5	02	10.8	7	2	$\varnothing 1.4$	KQ2H02-M5N
							04	14.7	8	4	$\varnothing 2.5$	KQ2H04-M5N

### Dimensions Per Vacuum Inlet: Barb Fitting

	Model						A	Fitting part min. hole size	Fitting part no.	
	① Adapter material	Vacuum inlet direction	② Pad dia.	Form	③ Material*1	④ Connection thread				⑤ Vacuum inlet
ZP3	Nil	Y	04 06 08	B	N S U F GN GS	B5	U2	6.5	$\varnothing 0.9$	M-5AU-2
							U4	8.5	$\varnothing 1.8$	M-5AU-4

\*1 N: NBR, S: Silicone rubber, U: Urethane rubber, F: FKM, GN: Conductive NBR, GS: Conductive silicone rubber

\*2 Indicates the minimum hole size of the adapter or vacuum pad

**Dimensions/Models**

**With buffer  $\varnothing 4$  to  $\varnothing 8$**

**ZP3 - T 04 B N J 3 - B5**

① ② ③ ④ ⑤ Vacuum inlet

**Buffer specification ③**

<b>J</b>	Rotating
<b>JB</b>	Rotating, With bushing
<b>K</b>	Non-rotating

<b>B5</b>	M5 x 0.8	Female thread
<b>02</b>	$\varnothing 2$	One-touch fitting
<b>04</b>	$\varnothing 4$	Barb fitting
<b>U2</b>	For $\varnothing 2$ polyurethane tubing	
<b>U4</b>	For $\varnothing 4$ soft tubing	

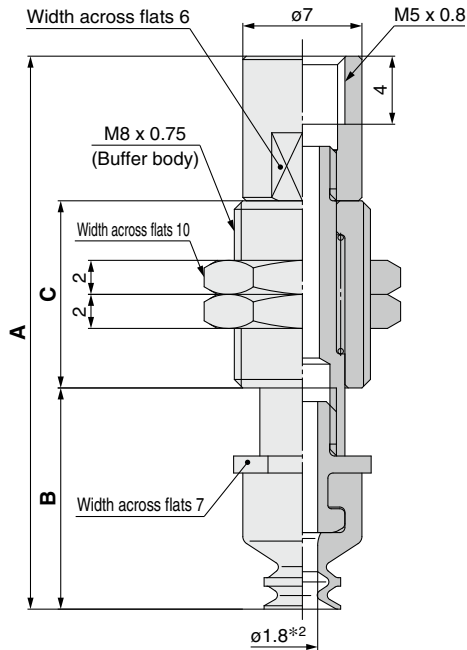

		Model					A	B	C	
Vacuum inlet direction	① Pad dia.	Form	② <sup>*1</sup> Material	③ Buffer spec.	④ Buffer stroke	⑤ Vacuum inlet				
ZP3	T	04 06 08	B	N S U F GN GS	J K	3	B5	32.5	13	11
						6		39	16	14.5
						10		49	20	20.5
					JB K	15		57	38.5	10
						20		64.5	46	

**Vacuum inlet: One-touch fitting**

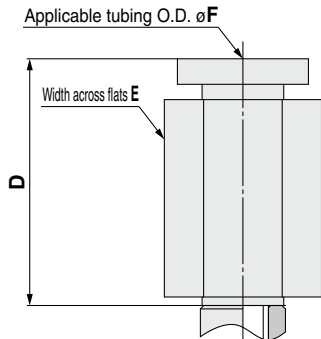

**Dimensions Per Vacuum Inlet: One-touch Fitting**

		Model					D	E	F	Fitting part min. hole size	Fitting part no.	
Vacuum inlet direction	① Pad dia.	Form	② <sup>*1</sup> Material	③ Buffer spec.	④ Buffer stroke	⑤ Vacuum inlet						
ZP3	T	04 06 08	B	N S U F GN GS	J JB K	3	02	10.8	7	2	$\varnothing 1.4$	KQ2H02-M5N
						6		14.7	8	4	$\varnothing 2.5$	KQ2H04-M5N
						10 15 20						

**Vacuum inlet: Barb fitting**

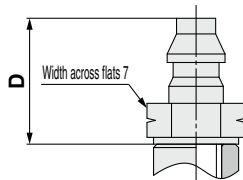

**Dimensions Per Vacuum Inlet: Barb Fitting**

		Model					D	Fitting part min. hole size	Fitting part no.	
Vacuum inlet direction	① Pad dia.	Form	② <sup>*1</sup> Material	③ Buffer spec.	④ Buffer stroke	⑤ Vacuum inlet				
ZP3	T	04 06 08	B	N S U F GN GS	J JB K	3	U2	6.5	$\varnothing 0.9$	M-5AU-2
						6 10 15 20		8.5	$\varnothing 1.8$	M-5AU-4

\*1 N: NBR, S: Silicone rubber, U: Urethane rubber, F: FKM, GN: Conductive NBR, GS: Conductive silicone rubber

\*2 Indicates the minimum hole size of the adapter or vacuum pad

- Construction p. 161
- Buffer Assembly p. 164

## Dimensions/Models

### With buffer $\phi 4$ to $\phi 8$

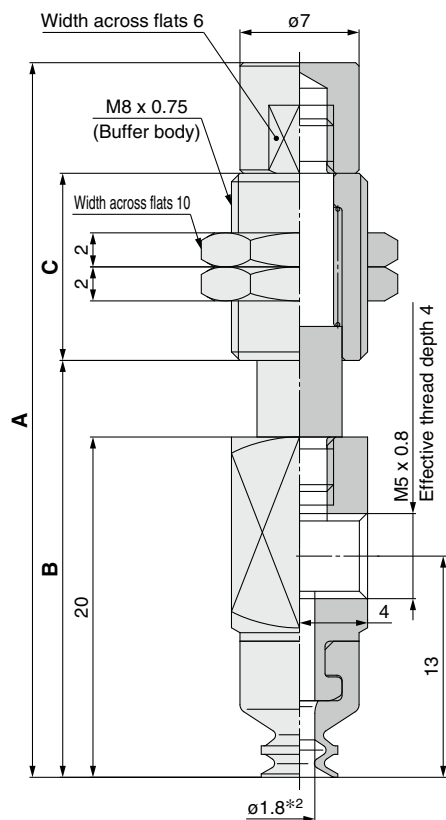

ZP3 - Y **04** **B** **N** **J** **3** - **B5**

**Buffer specification 3**

<b>J</b>	Rotating
<b>JB</b>	Rotating, With bushing
<b>K</b>	Non-rotating

**5 Vacuum inlet**

<b>B5</b>	M5 x 0.8	Female thread
<b>02</b>	$\phi 2$	One-touch fitting
<b>04</b>	$\phi 4$	Barb fitting
<b>U2</b>	For $\phi 2$ polyurethane tubing	
<b>U4</b>	For $\phi 4$ soft tubing	

		Model					A	B	C	
Vacuum inlet direction	1 Pad dia.	Form	2 Material	3 Buffer spec.	4 Buffer stroke	5 Vacuum inlet				
ZP3	Y	04 06 08	B	N S U F GN GS	J K	3	B5	42	11	
						6		24.5		
						10		14.5		
						15		20.5		
						JB K		20		61
										68.5
						52	10			

### Dimensions Per Vacuum Inlet: One-touch Fitting

		Model					D	E	F	Fitting part min. hole size	Fitting part no.	
Vacuum inlet direction	1 Pad dia.	Form	2 Material	3 Buffer spec.	4 Buffer stroke	5 Vacuum inlet						
ZP3	Y	04 06 08	B	N S U F GN GS	J JB K	3	02	10.8	7	2	$\phi 1.4$	KQ2H02-M5N
						6						
						10						
						15						
					20	04	14.7	8	4	$\phi 2.5$	KQ2H04-M5N	

### Dimensions Per Vacuum Inlet: Barb Fitting

		Model					D	Fitting part min. hole size	Fitting part no.			
Vacuum inlet direction	1 Pad dia.	Form	2 Material	3 Buffer spec.	4 Buffer stroke	5 Vacuum inlet						
ZP3	Y	04 06 08	B	N S U F GN GS	J JB K	3	U2	6.5	$\phi 0.9$	M-5AU-2		
						6						
						10		8.5			$\phi 1.8$	M-5AU-4
						15						
					20	U4						

\*1 N: NBR, S: Silicone rubber, U: Urethane rubber, F: FKM, GN: Conductive NBR, GS: Conductive silicone rubber

\*2 Indicates the minimum hole size of the adapter or vacuum pad

### Vacuum inlet: One-touch fitting

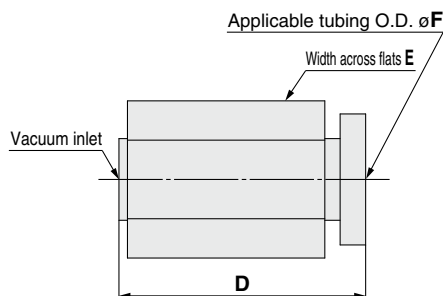

### Vacuum inlet: Barb fitting

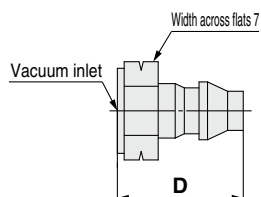

Construction p. 161

Buffer Assembly p. 164



# Compact Type Bellows Type with Ribs

## ZP3 Series

Pad diameter:  $\varnothing 10, \varnothing 13, \varnothing 16$



Model Selection

ZP3 Compact

Flat Type

Flat Type with Groove

Bellows Type

Bellows Type with Ribs

Construction

Mounting Bracket Assembly

Precautions

### How to Order

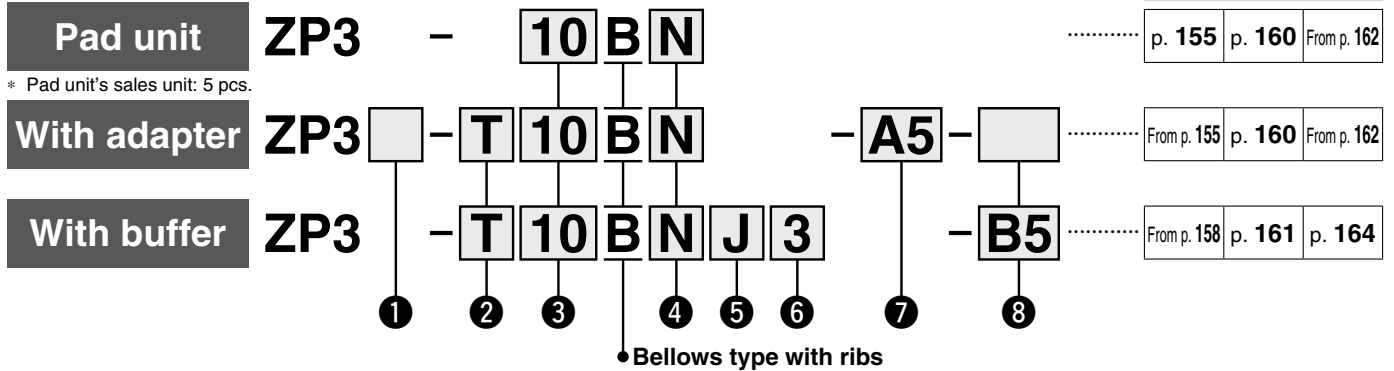

#### ① Adapter material

Nil	Brass
S*1	Stainless steel (Stainless steel 304)

\*1 Only applicable to the pad with adapter

#### ② Vacuum inlet direction

Nil	Pad unit
T	Vertical
Y	Lateral

#### ③ Pad diameter

10	$\varnothing 10$
13	$\varnothing 13$
16	$\varnothing 16$

#### ④ Material

N	NBR
S	Silicone rubber*1 *2
U	Urethane rubber
F	FKM
GN	Conductive NBR
GS	Conductive silicone rubber

\*1 Uses a material compliant with a dissolution test of the FDA (U.S. Food and Drug Administration) regulation 21CFR§177.2600 for "Rubber articles intended for repeated use."

\*2 Uses a material compliant with the standards for "Rubber apparatus (excluding baby drinking apparatus) and containers/packaging" (D3) (Partial revision: Japanese Ministry of Health, Labour, and Welfare Notification No. 595, 2012) in Section 3 "Apparatus and Containers/Packaging" of the Japan Food Sanitation Act, Article 18 "Specifications and Standards for Food and Food Additives, etc." (Japanese Ministry of Health and Welfare Notification No. 370, 1959)

#### ⑤ Buffer specification

J	Rotating
JB	Rotating, With bushing
K	Non-rotating

#### ⑥ Buffer stroke

Stroke [mm]	Buffer specification		
	J	JB	K
3	●	—	●
6	●	—	●
10	●	—	●
15	—	●	●
20	—	●	●

### With adapter

#### ⑦ Connection thread/⑧ Vacuum inlet ○: ZP3□-T/Vertical ●: ZP3□-Y/Lateral

⑦ Connection thread			⑧ Vacuum inlet			Pad diameter All sizes
Type	Symbol	Size	Type	Symbol	Size	
Male thread	A5	M5 x 0.8	—	Nil	Use the connection thread.	○
			Female thread	B5	M5 x 0.8	○
			One-touch fitting	02*3	$\varnothing 2$	○
	04	$\varnothing 4$		○		
	06	$\varnothing 6$		○		
	Female thread	B5	M5 x 0.8	Barb fitting*3	U2	For $\varnothing 2$ polyurethane tubing
U4					For $\varnothing 4$ soft tubing	○
U6					For $\varnothing 6$ soft tubing	○
—				Nil	Use the connection thread.	○
One-touch fitting*3				B5	M5 x 0.8	●
				02	$\varnothing 2$	●
	04	$\varnothing 4$	●			
Barb fitting*3	U2	For $\varnothing 2$ polyurethane tubing*1	●			
	U4	For $\varnothing 4$ soft tubing*2	●			
	U6	For $\varnothing 6$ soft tubing*2	●			

\*1 Polyurethane tube piping

\*2 Soft nylon/Polyurethane tube piping

\*3 Not compatible with stainless steel materials

### With buffer

#### ⑧ Vacuum inlet ○: ZP3-T/Vertical ●: ZP3-Y/Lateral

Type	Symbol	Size	Pad diameter All sizes
Female thread	B5	M5 x 0.8	○●
One-touch fitting	02	$\varnothing 2$	○●
	04	$\varnothing 4$	○●
	06	$\varnothing 6$	○●
Barb fitting	U2	For $\varnothing 2$ polyurethane tubing	○●
	U4	For $\varnothing 4$ soft tubing	○●
	U6	For $\varnothing 6$ soft tubing	○●

\* It is not necessary to select a connection thread.

\* The pad, mounting nut, and fitting are shipped together but do not come assembled.

## Dimensions/Models

### Single unit $\varnothing 10$ to $\varnothing 16$

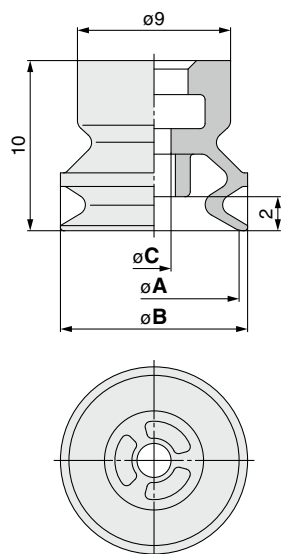

**ZP3 - 10 B N**  
① ②

Model	Model		A	B	C
	① Pad dia.	② Form			
ZP3	10	B	10	11	2
	13		13	14	3
	16		16	17	

\*1 N: NBR, S: Silicone rubber, U: Urethane rubber, F: FKM, GN: Conductive NBR, GS: Conductive silicone rubber

Construction p. 160

Mounting Bracket Assembly From p. 162

### With adapter $\varnothing 10$ to $\varnothing 16$

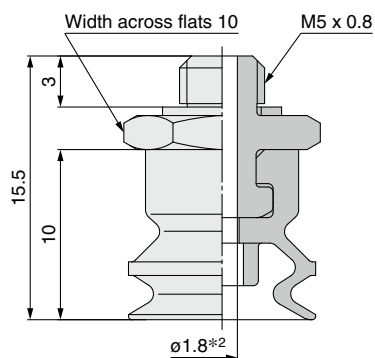

Construction p. 160

Adapter Assembly p. 162

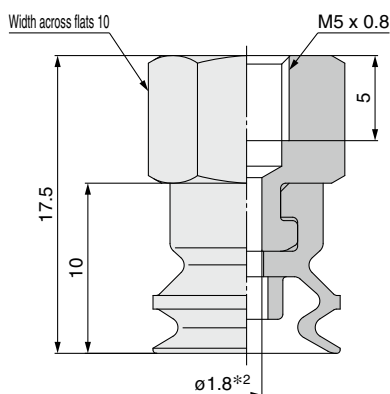

Construction p. 160

Adapter Assembly p. 162

**ZP3 - T 10 B N - A5**  
① ② ③ ④

① Adapter material

Nil	Brass
S	Stainless steel (Stainless steel 304)

④ Connection thread (Male thread)

A5	M5 x 0.8
----	----------

Model	Model		A	B	C	
	① Adapter material	② Vacuum inlet direction				
ZP3	Nil S	T	10	B	N S U F GN GS	
			13			A5
			16			

\*1 N: NBR, S: Silicone rubber, U: Urethane rubber, F: FKM, GN: Conductive NBR, GS: Conductive silicone rubber

\*2 Indicates the minimum hole size of the adapter or vacuum pad

**ZP3 - T 10 B N - B5**  
① ② ③ ④

① Adapter material

Nil	Brass
S	Stainless steel (Stainless steel 304)

④ Connection thread (Female thread)

B5	M5 x 0.8
----	----------

Model	Model		A	B	C	
	① Adapter material	② Vacuum inlet direction				
ZP3	Nil S	T	10	B	N S U F GN GS	
			13			B5
			16			

\*1 N: NBR, S: Silicone rubber, U: Urethane rubber, F: FKM, GN: Conductive NBR, GS: Conductive silicone rubber

\*2 Indicates the minimum hole size of the adapter or vacuum pad

**Dimensions/Models**

**With adapter  $\varnothing 10$  to  $\varnothing 16$**

ZP3   - T 10 B N - A12 - B5

1    
 2    
 3    
 4    
 5

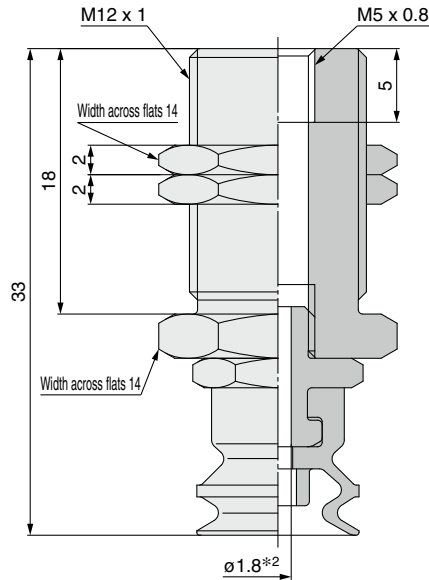

**1 Adapter material**

Nil	Brass
S	Stainless steel (Stainless steel 304)

**4 Connection thread (Male thread)**

A12	M12 x 1
-----	---------

**5 Vacuum inlet**

B5	M5 x 0.8	Female thread
02*1	$\varnothing 2$	One-touch fitting
04	$\varnothing 4$	
06	$\varnothing 6$	
U2*1	For $\varnothing 2$ polyurethane tubing	Barb fitting
U4*1	For $\varnothing 4$ soft tubing	
U6*1	For $\varnothing 6$ soft tubing	

\*1 Not compatible with stainless steel materials

Model							
	1 Adapter material	2 Vacuum inlet direction	3 Pad dia.	4 Form	5 Material*1	6 Connection thread	7 Vacuum inlet
ZP3	Nil S	T	10 13 16	B	N S U F GN GS	A12	B5

**Vacuum inlet: One-touch fitting ( $\varnothing 2$ )**

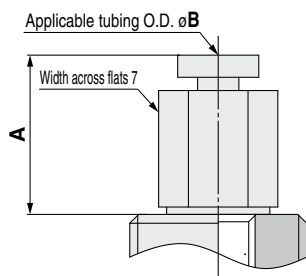

**Vacuum inlet: Built-in One-touch fitting ( $\varnothing 4, \varnothing 6$ )**

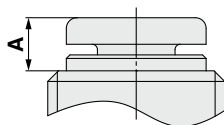

**Vacuum inlet: Barb fitting**

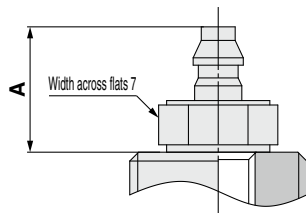

**Dimensions Per Vacuum Inlet: One-touch Fitting**

Model							A	B	Fitting part min. hole size	Fitting part no.	
1 Adapter material	2 Vacuum inlet direction	3 Pad dia.	4 Form	5 Material*1	6 Connection thread	7 Vacuum inlet					
ZP3	Nil S	T	10 13 16	B	N S U F GN GS	A12	02*3	10.8	2	$\varnothing 1.4$	KQ2H02-M5N
							04	3	4	$\varnothing 1.8$	
							06	3.2	6		

\*3 Not compatible with stainless steel materials

**Dimensions Per Vacuum Inlet: Barb Fitting**

Model							A	Fitting part min. hole size	Fitting part no.	
1 Adapter material	2 Vacuum inlet direction	3 Pad dia.	4 Form	5 Material*1	6 Connection thread	7 Vacuum inlet				
ZP3	Nil	T	10 13 16	B	N S U F GN GS	A12	U2	6.5	$\varnothing 0.9$	M-5AU-2
							U4	8.5	$\varnothing 1.8$	M-5AU-4
							U6	10.5	$\varnothing 2.5$	M-5AU-6

\*1 N: NBR, S: Silicone rubber, U: Urethane rubber, F: FKM, GN: Conductive NBR, GS: Conductive silicone rubber

\*2 Indicates the minimum hole size of the adapter or vacuum pad

Construction p. 160

Adapter Assembly p. 163

**Dimensions/Models**

**With adapter  $\varnothing 10$  to  $\varnothing 16$**

ZP3   - Y 10 B N - B5 - B5  
①   ②   ③   ④   ⑤

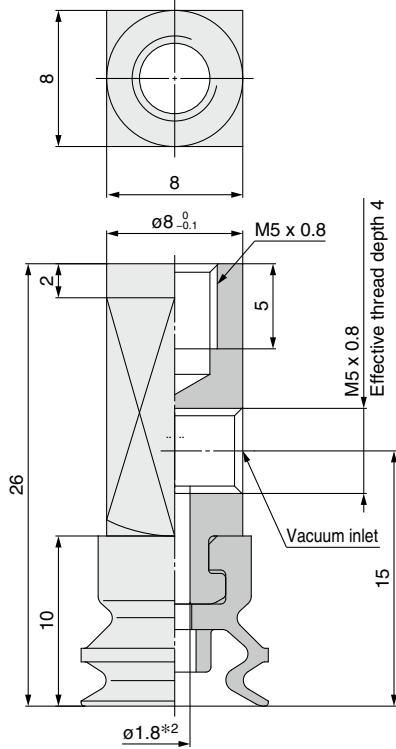

**Vacuum inlet: One-touch fitting**

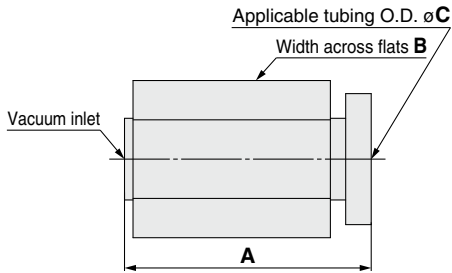

**Vacuum inlet: Barb fitting**

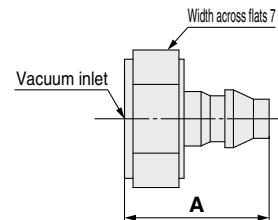

**Construction** p. 160

**Adapter Assembly** p. 162

**① Adapter material**

<b>Nil</b>	Brass
<b>S</b>	Stainless steel (Stainless steel 304)

**④ Connection thread (Female thread)**

<b>B5</b>	M5 x 0.8
-----------	----------

**⑤ Vacuum inlet**

<b>B5</b>	M5 x 0.8	Female thread
<b>02</b>	$\varnothing 2$	One-touch fitting*1
<b>04</b>	$\varnothing 4$	
<b>06</b>	$\varnothing 6$	
<b>U2</b>	For $\varnothing 2$ polyurethane tubing	Barb fitting*1
<b>U4</b>	For $\varnothing 4$ soft tubing	
<b>U6</b>	For $\varnothing 6$ soft tubing	

\*1 Not compatible with stainless steel materials

Model							
	① Adapter material	Vacuum inlet direction	② Pad dia.	Form	③ Material*1	④ Connection thread	⑤ Vacuum inlet
ZP3	Nil S	Y	10 13 16	B	N S U F GN GS	B5	B5

**Dimensions Per Vacuum Inlet: One-touch Fitting**

Model							A	B	C	Fitting part min. hole size	Fitting part no.	
	① Adapter material	Vacuum inlet direction	② Pad dia.	Form	③ Material*1	④ Connection thread	⑤ Vacuum inlet					
ZP3	Nil	Y	10 13 16	B	N S U F GN GS	B5	02	10.8	7	2	$\varnothing 1.4$	KQ2H02-M5N
							04	14.7	8	4	$\varnothing 2.5$	KQ2H04-M5N
							06		10	6		KQ2H06-M5N

**Dimensions Per Vacuum Inlet: Barb Fitting**

Model							A	Fitting part min. hole size	Fitting part no.	
	① Adapter material	Vacuum inlet direction	② Pad dia.	Form	③ Material*1	④ Connection thread	⑤ Vacuum inlet			
ZP3	Nil	Y	10 13 16	B	N S U F GN GS	B5	U2	6.5	$\varnothing 0.9$	M-5AU-2
							U4	8.5	$\varnothing 1.8$	M-5AU-4
							U6	10.5	$\varnothing 2.5$	M-5AU-6

\*1 N: NBR, S: Silicone rubber, U: Urethane rubber, F: FKM, GN: Conductive NBR, GS: Conductive silicone rubber

\*2 Indicates the minimum hole size of the adapter or vacuum pad

**Dimensions/Models**

**With buffer  $\varnothing 10$  to  $\varnothing 16$**

**ZP3 - T 10 B N J 3 - B5**

①
②
③
④
⑤

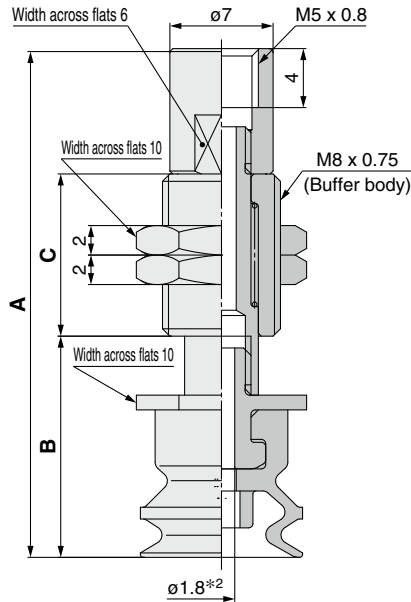

**Buffer specification ③**

<b>J</b>	Rotating
<b>JB</b>	Rotating, With bushing
<b>K</b>	Non-rotating

**⑤ Vacuum inlet**

<b>B5</b>	M5 x 0.8	Female thread
<b>02</b>	$\varnothing 2$	One-touch fitting
<b>04</b>	$\varnothing 4$	
<b>06</b>	$\varnothing 6$	
<b>U2</b>	For $\varnothing 2$ polyurethane tubing	
<b>U4</b>	For $\varnothing 4$ soft tubing	
<b>U6</b>	For $\varnothing 6$ soft tubing	

		Model					A	B	C	
	Vacuum inlet direction	① Pad dia.	Form	② <sup>*1</sup> Material	③ Buffer spec.	④ Buffer stroke				⑤ Vacuum inlet
ZP3	T	10 13 16	B	N S U F GN GS	J K JB K	3	B5	34.5	15	11
						6		41	18	14.5
						10		51	22	20.5
						15		59	40.5	
						20		66.5	48	10

**Dimensions Per Vacuum Inlet: One-touch Fitting**

		Model					D	E	F	Fitting part min. hole size	Fitting part no.	
	Vacuum inlet direction	① Pad dia.	Form	② <sup>*1</sup> Material	③ Buffer spec.	④ Buffer stroke						⑤ Vacuum inlet
ZP3	T	10 13 16	B	N S U F GN GS	J JB K	3	02 04 06	10.8	7	2	$\varnothing 1.4$	KQ2H02-M5N
						6		14.7	8	4	$\varnothing 2.5$	KQ2H04-M5N
						10			10	6	KQ2H06-M5N	
						15						
						20						

**Vacuum inlet: One-touch fitting**

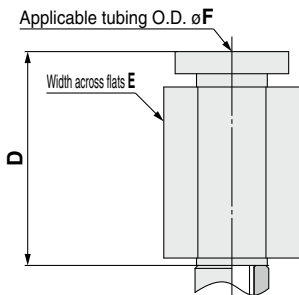

**Vacuum inlet: Barb fitting**

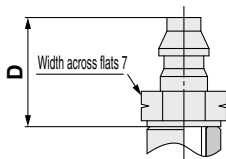

**Dimensions Per Vacuum Inlet: Barb Fitting**

		Model					D	Fitting part min. hole size	Fitting part no.	
	Vacuum inlet direction	① Pad dia.	Form	② <sup>*1</sup> Material	③ Buffer spec.	④ Buffer stroke				⑤ Vacuum inlet
ZP3	T	10 13 16	B	N S U F GN GS	J JB K	3	U2 U4 U6	6.5	$\varnothing 0.9$	M-5AU-2
						6		8.5	$\varnothing 1.8$	M-5AU-4
						10		10.5	$\varnothing 2.5$	M-5AU-6
						15				
						20				

\*1 N: NBR, S: Silicone rubber, U: Urethane rubber, F: FKM, GN: Conductive NBR, GS: Conductive silicone rubber

\*2 Indicates the minimum hole size of the adapter or vacuum pad

Construction	p. 161
Buffer Assembly	p. 164

## Dimensions/Models

**With buffer**  $\varnothing 10$  to  $\varnothing 16$

**ZP3 - Y 10 B N J 3 - B5**

① ② ③ ④

⑤ Vacuum inlet

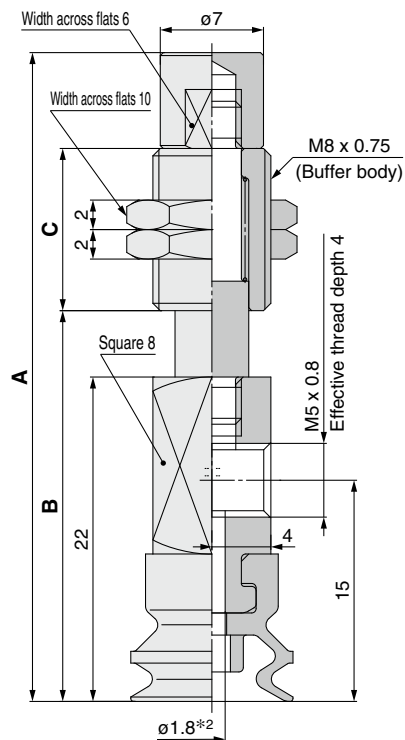

**Buffer specification ③**

<b>J</b>	Rotating
<b>JB</b>	Rotating, With bushing
<b>K</b>	Non-rotating

<b>B5</b>	M5 x 0.8	Female thread
<b>02</b>	$\varnothing 2$	One-touch fitting
<b>04</b>	$\varnothing 4$	
<b>06</b>	$\varnothing 6$	
<b>U2</b>	For $\varnothing 2$ polyurethane tubing	Barb fitting
<b>U4</b>	For $\varnothing 4$ soft tubing	
<b>U6</b>	For $\varnothing 6$ soft tubing	

		Model					A	B	C
Vacuum inlet direction	① Pad dia.	Form	② <sup>*1</sup> Material	③ Buffer spec.	④ Buffer stroke	⑤ Vacuum inlet			
ZP3	Y	B	N S U F GN GS	J K JB K	3	B5	44	26.5	11
					6		50	29	14.5
					10		60	33	20.5
					15		63	46.5	
					20		70.5	54	10

### Dimensions Per Vacuum Inlet: One-touch Fitting

		Model					D	E	F	Fitting part min. hole size	Fitting part no.	
Vacuum inlet direction	① Pad dia.	Form	② <sup>*1</sup> Material	③ Buffer spec.	④ Buffer stroke	⑤ Vacuum inlet						
ZP3	Y	B	N S U F GN GS	J JB K	3	02	10.8	7	2	$\varnothing 1.4$	KQ2H02-M5N	
					6							
					10							
					15		04	14.7	8	4	$\varnothing 2.5$	KQ2H04-M5N
					20							
					06							

### Dimensions Per Vacuum Inlet: Barb Fitting

		Model					D	Fitting part min. hole size	Fitting part no.	
Vacuum inlet direction	① Pad dia.	Form	② <sup>*1</sup> Material	③ Buffer spec.	④ Buffer stroke	⑤ Vacuum inlet				
ZP3	Y	B	N S U F GN GS	J JB K	3	U2	6.5	$\varnothing 0.9$	M-5AU-2	
					6					
					10					
					15		U4	8.5	$\varnothing 1.8$	M-5AU-4
					20					
					U6					

\*1 N: NBR, S: Silicone rubber, U: Urethane rubber, F: FKM, GN: Conductive NBR, GS: Conductive silicone rubber

\*2 Indicates the minimum hole size of the adapter or vacuum pad

### Vacuum inlet: One-touch fitting

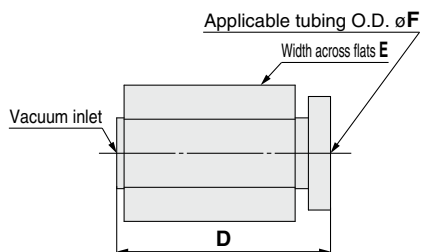

### Vacuum inlet: Barb fitting

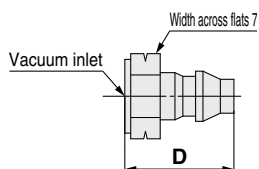

Construction	p. 161
Buffer Assembly	p. 164

# Compact Type ZP3 Series Construction

With adapter Flat type:  $\varnothing 1.5$  to  $\varnothing 3.5$  Flat type with groove:  $\varnothing 4$  to  $\varnothing 16$  Bellows type:  $\varnothing 4$  to  $\varnothing 8$  Bellows type with ribs:  $\varnothing 10$  to  $\varnothing 16$

## Vacuum inlet direction **Vertical** T Type/ZP3-T

ZP3-T-A

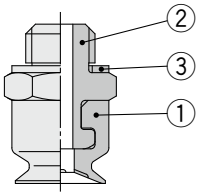

ZP3-T-B

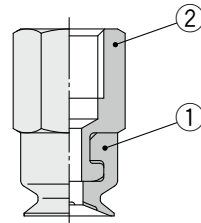

ZP3-T-A-B

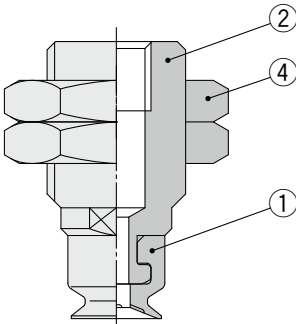

ZP3-T-A-(02/04)

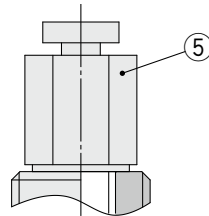

ZP3-T-A-(U2/U4/U6)

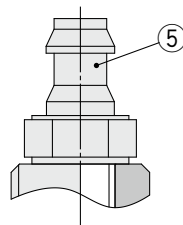

ZP3-T-A10-04  
ZP3-T-A12-(04/06)

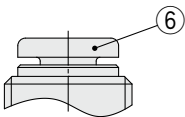

### Component Parts

No.	Description	Material	Note
1	Pad	NBR, Silicone rubber, Urethane rubber, FKM, Conductive NBR, Conductive silicone rubber	Flat type Flat type with groove Bellows type
		Semiconductive silicone rubber	Bellows type with ribs
		Semiconductive HNBR	Flat type with groove
2	Adapter	Brass (Electroless nickel plating)	ZP3-T
		Stainless steel	ZP3S-T
3	Gasket	Stainless steel/NBR	ZP3-T
		Stainless steel/FKM	ZP3S-T
4	Nut	Structural steel (Trivalent chromated)	M6 x 0.75
		Steel (Trivalent zinc chromated)	M12 x 1
		Stainless steel	M10 x 1
5	Fitting	—	ZP3-T
6	Cassette	—	ZP3S-T

## Vacuum inlet direction **Lateral** Y Type/ZP3-Y

ZP3-Y-B-B

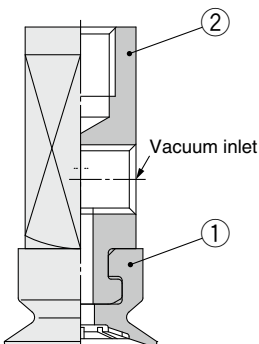

ZP3-Y-B-(02/04/06)

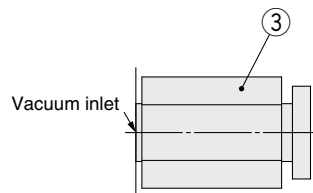

ZP3-Y-B-(U2/U4/U6)

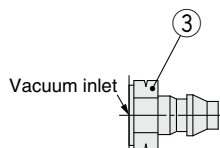

### Component Parts

No.	Description	Material	Note
1	Pad	NBR, Silicone rubber, Urethane rubber, FKM, Conductive NBR, Conductive silicone rubber	Flat type Flat type with groove Bellows type
		Semiconductive silicone rubber	Bellows type with ribs
		Semiconductive HNBR	Flat type with groove
2	Adapter	Brass (Electroless nickel plating)	ZP3-Y
		Stainless steel	ZP3S-Y
3	Fitting	—	

With buffer

Flat type:  $\varnothing 1.5$  to  $\varnothing 3.5$

Flat type with groove:  $\varnothing 4$  to  $\varnothing 16$

Bellows type:  $\varnothing 4$  to  $\varnothing 8$

Bellows type with ribs:  $\varnothing 10$  to  $\varnothing 16$

Vacuum inlet direction **Vertical** T Type/ZP3-T

ZP3-T□(J/K)□-B□

ZP3-T□JB□-B□

ZP3-T□K(15/20)□-B□

ZP3-T□-(02/04/06)

ZP3-T□-(U2/U4/U6)

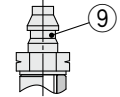
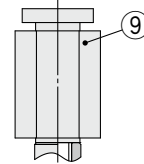
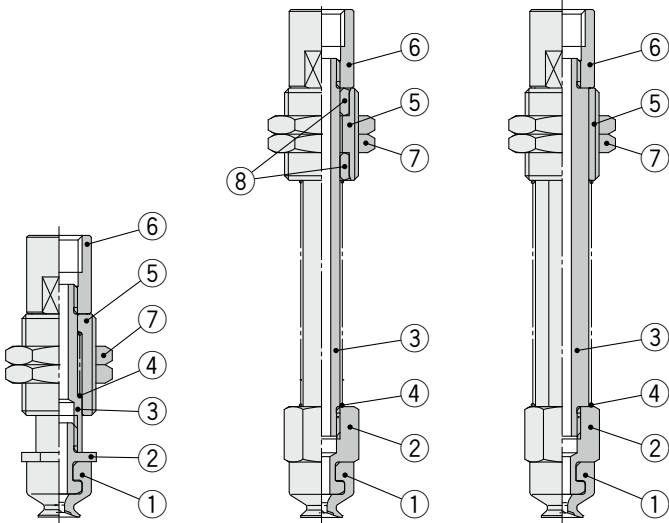

Component Parts

No.	Description	Material	Note
1	Pad	NBR, Silicone rubber, Urethane rubber, FKM, Conductive NBR, Conductive silicone rubber	Flat type Flat type with groove Bellows type Bellows type with ribs
		Semiconductive silicone rubber Semiconductive HNBR	Flat type with groove
2	Adapter	Brass (Electroless nickel plating)	
3	Piston rod	Stainless steel	
4	Return spring	Stainless steel	
5	Buffer body	Brass (Electroless nickel plating)	
6	Buffer adapter	Brass (Electroless nickel plating)	
7	Nut	Structural steel (Trivalent chromated)	M6 x 0.75 M8 x 0.75
8	Bushing	—	
9	Fitting	—	

Vacuum inlet direction **Lateral** Y Type/ZP3-Y

ZP3-Y□(J/K)□-B□

ZP3-Y□JP□-B□

ZP3-Y□K(15/20)□-B□

ZP3-Y□-(02/04/06)

ZP3-Y□-(U2/U4/U6)

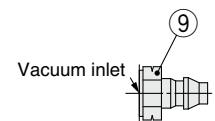
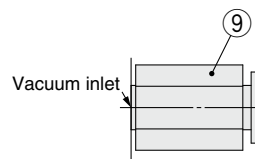
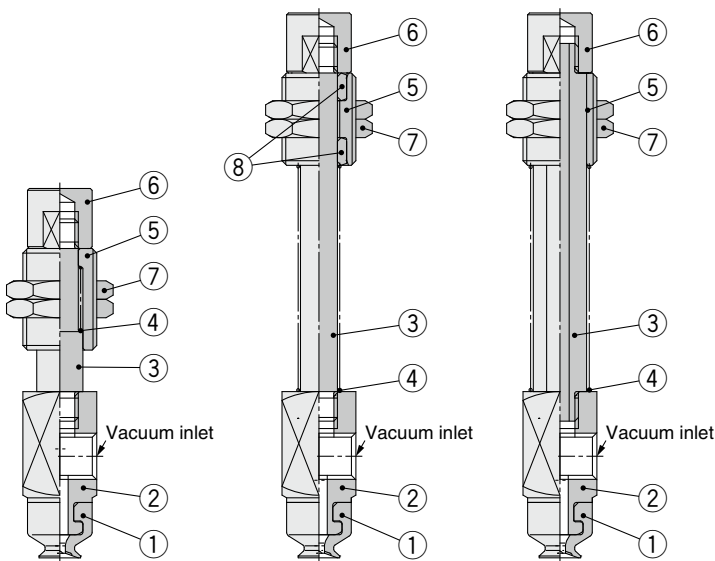

Component Parts

No.	Description	Material	Note
1	Pad	NBR, Silicone rubber, Urethane rubber, FKM, Conductive NBR, Conductive silicone rubber	Flat type Flat type with groove Bellows type Bellows type with ribs
		Semiconductive silicone rubber Semiconductive HNBR	Flat type with groove
2	Adapter	Brass (Electroless nickel plating)	
3	Piston rod	Stainless steel	
4	Return spring	Stainless steel	
5	Buffer body	Brass (Electroless nickel plating)	
6	Buffer adapter	Brass (Electroless nickel plating)	
7	Nut	Structural steel (Trivalent chromated)	M6 x 0.75 M8 x 0.75
8	Bushing	—	
9	Fitting	—	





# Basic/Compact Type Specific Product Precautions

Be sure to read this before handling the products.

For safety instructions, refer to the “Handling Precautions for SMC Products” and the “Operation Manual” on the SMC website: <https://www.smcworld.com>

## Mounting

### 1. Tighten the screw within the specified torque range when mounting the buffer.

Tightening with a torque outside of the specified range may cause malfunction.

#### Basic Type ZP Series

Product part number	Connection thread	Tightening torque [N·m]
ZP□(2 to 8)□(J/K)□-□-A8	M8 x 1	1.5 to 2.0
ZP□(10 to 32)□(J/K)□-□-A10	M10 x 1	2.5 to 3.5
ZP□(40/50)□(J/K)□-□-A14	M14 x 1	6.5 to 7.5

#### Compact Type ZP3 Series

Product part number	Connection thread	Tightening torque [N·m]
ZP3□-□(015 to 035)□J□-□	M6 x 0.75	1.5 to 1.8
ZP3□-□(015 to 035)□K□-□	M8 x 0.75	2.0 to 2.5
ZP3□-□(04 to 16)□(J/JB/K)□-□		

### 2. When mounting the product, tighten with the tightening torque shown in the table below. If excessive or insufficient tightening torque is applied, sealing failure or loose screws may result.

#### Basic Type ZP Series

Product part number	Connection thread	Tightening torque [N·m]
ZP□T□□-A5	M5 x 0.8	1.3 to 1.7
ZP□T□□-AS5		
ZP□T□□-A6	M6 x 1	1.6 to 2
ZP□T□□-AS6		
ZP□T□□-AG01	G1/8	3 to 5
ZP□T□□-AG02	G1/4	8 to 12

#### Compact Type ZP3 Series

Product part number	Connection thread	Tightening torque [N·m]
ZP3□-T(015 to 035)U□-A3	M3 x 0.5	0.2 to 0.25
ZP3□-T(04 to 16)□□-A5	M5 x 0.8	1.3 to 1.7

Product part number	Connection thread	Tightening torque [N·m]
ZP□T□□-BG01	G1/8	3 to 5
ZP□T□□-BG02	G1/4	8 to 12

## How to Replace the Pad

### 1. How to replace the pad of the basic type ZP series

- 1 Pull the lock ring upward, and, after lifting it up to the adapter, remove the old pad by pulling it downward.
- 2 While holding the lock ring in the raised position, place a new pad onto the adapter.
- 3 Confirm that the pad is securely in place, and then return the lock ring to its original position.

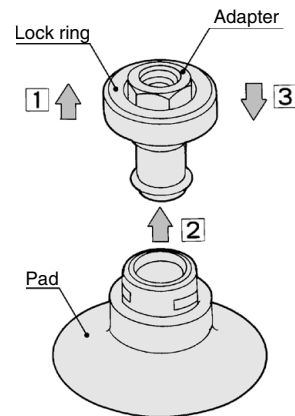

### 2. How to replace the pad of the basic (ball joint) type ZP series

#### Pad diameter: $\varnothing 10$ to $\varnothing 32$

- 1 Insert a hexagon wrench into the bottom of the pad, loosen the screw, and remove the old pad from the adapter.
- 2 Place a new pad on the adapter, and, after confirming that the O-ring is in place, retighten the screw with the hexagon wrench.

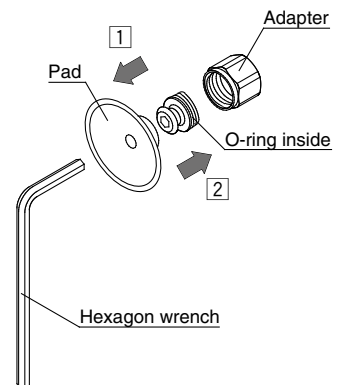

#### Pad diameter: $\varnothing 40$ , $\varnothing 50$

- 1 Pull the lock ring upward, and, after lifting it up to the adapter, remove the old pad by pulling it downward.
- 2 While holding the lock ring in the raised position, place a new pad onto the adapter.
- 3 Confirm that the pad is securely in place, and then return the lock ring to its original position.

