

Oval Pad *ZP/ZP2 Series*

RoHS

Model Selection

2 x 4, 3.5 x 7, 4 x 10, 4 x 20, 4 x 30, 5 x 10, 5 x 20, 5 x 30, 6 x 10, 6 x 20, 6 x 30, 8 x 20, 8 x 30

Oval Flat Type

For rectangular, vertically long, and horizontally long workpieces

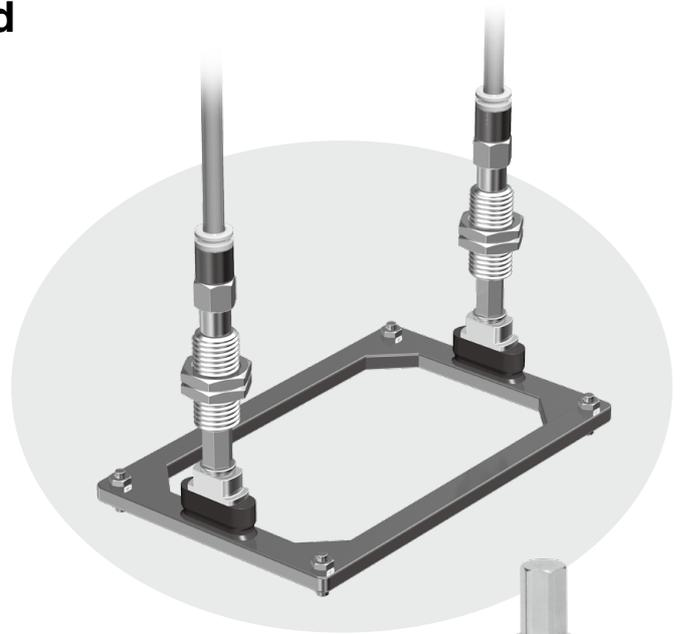
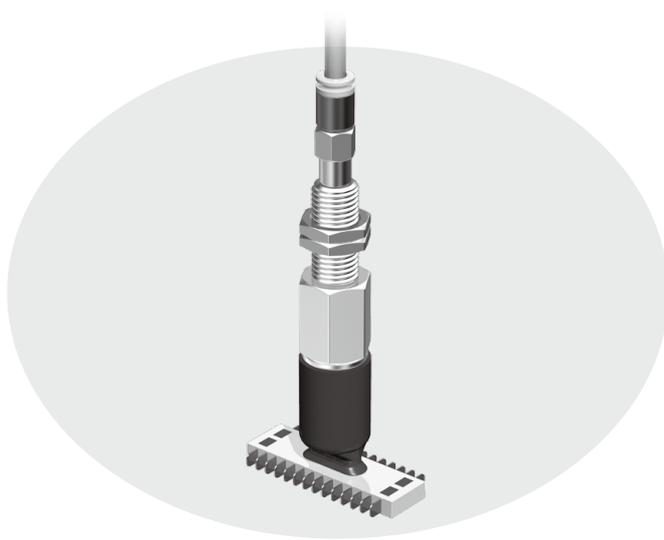

ZP Series

ZP2 Series

ZP Oval

ZP2 Oval

Construction

Mounting Bracket Assembly

CONTENTS

Oval Pad *ZP/ZP2 Series*

Variations	p. 167
Specifications	p. 168

Oval Flat Type/ZP Series

· How to Order	p. 170
· Dimensions/Models	p. 171

Oval Flat Type/ZP2 Series

· How to Order	p. 179
· Dimensions/Models	p. 180

Construction

ZP Series	p. 185
ZP2 Series	p. 187

Mounting Bracket Assembly

ZP Series	p. 189
ZP2 Series	p. 195

Specific Product Precautions	p. 198
------------------------------------	--------

Precautions

ZP Series

		Vacuum inlet direction	Oval flat type
Vacuum inlet direction	Single unit		p. 171
Vertical	ZPT With adapter		p. 171
Lateral	ZPR With adapter		p. 172 p. 173
Lateral	ZPY With adapter		p. 174 p. 175
Vertical	ZPT With buffer		p. 176
Lateral	ZPR With buffer		p. 177
Lateral	ZPY With buffer		p. 178

ZP2 Series

		Vacuum inlet direction	Oval flat type
Vacuum inlet direction	Single unit		p. 180
Vertical	ZP2-T With adapter		p. 180
Lateral	ZP2-R With adapter		p. 181 p. 182
Vertical	ZP2-T With buffer		p. 183
Lateral	ZP2-R With buffer		p. 184

Oval Pad *ZP/ZP2* Series Specifications

Pad Material: ZP/ZP2 Series

Material	NBR (Nitrile rubber)	Silicone rubber*1*2	Urethane rubber	FKM (Fluoro rubber)	Conductive NBR (Nitrile rubber)	Conductive silicone rubber
Color of rubber	Black	White	Brown	Black		
Rubber hardness (Shore A: ±5°)	50	40	55 to 60	60	60 to 70	50 to 60

*1 Compliant with the FDA (USA Food and Drug Administration) regulation 21CFR§177.2600 for "Rubber articles intended for repeated use"

*2 Compliant with the standards for "Rubber apparatus (excluding baby drinking apparatus) and containers/packaging" (D3) (Partial revision: Ministry of Health, Labour, and Welfare Notification No. 595, 2012) in Section 3 "Apparatus and Containers/Packaging" of the Japan Food Sanitation Act, Article 18 "Specifications and Standards for Food and Food Additives, etc." (Ministry of Health and Welfare Notification No. 370, 1959).

Adapter Specifications: ZP Series

Vacuum Inlet Direction **Vertical** T Type/ZPT

Connection		Male thread	Female thread
Pad size		2004, 3507, 4010	2004, 3507, 4010
Connection thread		M5 x 0.8 M6 x 1	M4 x 0.7 M5 x 0.8
Vacuum inlet		Use the connection thread.	



Vacuum Inlet Direction **Lateral** R Type/ZPR

Connection		Male thread	Female thread
Pad size		2004, 3507, 4010	2004, 3507, 4010
Connection thread		M5 x 0.8 M6 x 1	M4 x 0.7 M5 x 0.8
Vacuum inlet	One-touch fitting	ø4, ø6	ø4, ø6



Vacuum Inlet Direction **Lateral** Y Type/ZPY

Connection		Male thread	Female thread
Pad size		2004, 3507, 4010	2004, 3507, 4010
Connection thread		M5 x 0.8 M6 x 1	M4 x 0.7 M5 x 0.8
Vacuum inlet	Barb fitting (Nylon tubing)	ø4, ø6	ø4, ø6
	Barb fitting (Soft tubing)		

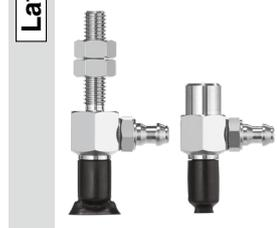

Buffer Specifications: ZP Series

Pad size		2004, 3507, 4010
Non-rotating specification		J: Rotating, K: Non-rotating
Stroke [mm]		6, 10, 15, 25
Connection thread		M8 x 1
Spring reactive force [N]	At 0 stroke	0.8
	At full stroke	1.2

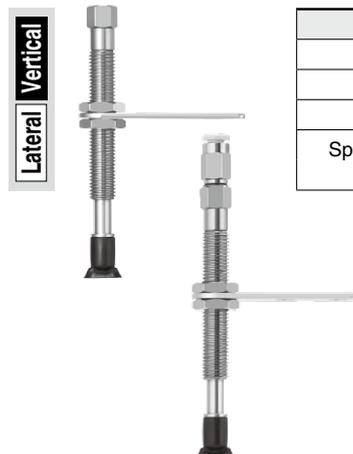

Adapter Specifications: ZP2 Series

Vertical



Vacuum Inlet Direction **Vertical** T Type/ZP2-T

Connection	Female thread
Pad size	3507 to 8030
Connection thread	M5 x 0.8
Vacuum inlet	Use the connection thread.

Lateral



Vacuum Inlet Direction **Lateral** R Type/ZP2-R

Connection	Male thread	Female thread
Pad size	3507 to 8030	3507 to 8030
Connection thread	M5 x 0.8	M5 x 0.8
Vacuum inlet	One-touch fitting	ø4, ø6

Buffer Specifications: ZP2 Series

Vertical

Lateral



Pad diameter	3507 to 8030	
Non-rotating specification	K: Non-rotating	
Stroke [mm]	10, 20, 30, 40, 50	
Connection thread	M10 x 1	
Spring reactive force [N]	At 0 stroke	1.0
	At full stroke	3.0



Oval Pad

Oval Flat Type

ZP Series



Model Selection

How to Order

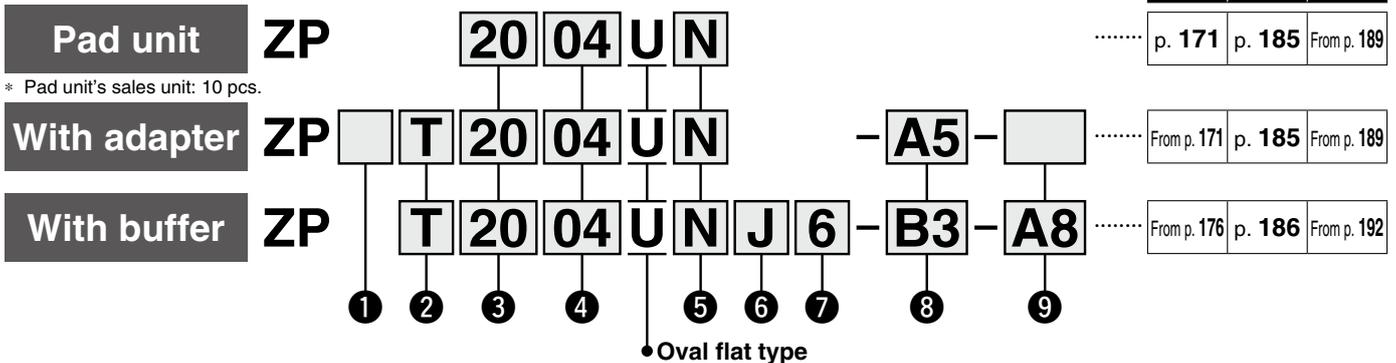

① Adapter material

Nil	Brass
S*1	Stainless steel (Stainless steel 304)

*1 Only applicable to the pad with adapter (Vacuum inlet direction: Vertical (Option "T"))

② Vacuum inlet direction

Nil	Pad unit
T	Vertical
R	Lateral (With One-touch fitting)
Y	Lateral (With barb fitting)

③/④ Pad size

Symbol	④ Length		
	04	07	10
③ Breadth	20 (2 x 4)	—	—
	35	—	—
	40	—	—

⑤ Material

N	NBR
S	Silicone rubber*1 *2
U	Urethane rubber
F	FKM
GN	Conductive NBR
GS	Conductive silicone rubber

*1 Compliant with the FDA (USA Food and Drug Administration) regulation 21CFR§177.2600 for "Rubber articles intended for repeated use"

*2 Compliant with the standards for "Rubber apparatus (excluding baby drinking apparatus) and containers/packaging" (D3) (Partial revision: Ministry of Health, Labour, and Welfare Notification No. 595, 2012) in Section 3 "Apparatus and Containers/Packaging" of the Japan Food Sanitation Act, Article 18 "Specifications and Standards for Food and Food Additives, etc." (Ministry of Health and Welfare Notification No. 370, 1959)

⑥ Buffer specification

J	Rotating
K	Non-rotating
JN	Rotating (Without buffer plate)
KN	Non-rotating (Without buffer plate)

⑦ Buffer stroke

Stroke [mm]	Pad size
	All sizes
6	●
10	●
15	●
25	●

With adapter

⑧ Vacuum inlet

○: ZP□T/Vertical ●: ZPR/Lateral (With One-touch fitting) △: ZPY/Lateral (With barb fitting)

Type	Symbol	Size	Pad diameter
			All sizes
Male thread	A5	M5 x 0.8	○
	A6	M6 x 1	○
Female thread	B4	M4 x 0.7	○
	B5	M5 x 0.8	○
One-touch fitting	04	ø4	●
	06	ø6	●
Barb fitting	N4	For ø4 nylon tubing	△
	N6	For ø6 nylon tubing	△
	U4	For ø4 soft tubing	△
	U6	For ø6 soft tubing	△

⑨ Connection thread ●: ZPR/Lateral (With One-touch fitting) △: ZPY/Lateral (With barb fitting)

Type	Symbol	Size	Pad diameter
			All sizes
Male thread	A5	M5 x 0.8	●△
	A6	M6 x 1	●△
Female thread	B4	M4 x 0.7	●△
	B5	M5 x 0.8	●△

It is not necessary to select a connection thread for ○: ZP□T/Vertical. Use the vacuum inlet.

With buffer

⑧ Vacuum inlet

○: ZPT/Vertical ●: ZPR/Lateral (With One-touch fitting) △: ZPY/Lateral (With barb fitting)

Type	Symbol	Size	Pad diameter
			All sizes
Female thread	B3	M3 x 0.5	○
	B5	M5 x 0.8	○
One-touch fitting	04	ø4	○●
	06	ø6	○●
Barb fitting	N4	For ø4 nylon tubing*1	○△
	N6	For ø6 nylon tubing*1	△
	U4	For ø4 soft tubing*2	○△
	U6	For ø6 soft tubing*2	△

*1 Nylon tube piping

*2 Soft nylon/Polyurethane tube piping

⑨ Connection thread

○: ZPT/Vertical ●: ZPR/Lateral (With One-touch fitting) △: ZPY/Lateral (With barb fitting)

Type	Symbol	Size	Pad diameter
			All sizes
Male thread	A8	M8 x 1	○●△

* The pad, mounting nut, fitting, and buffer plate are shipped together but do not come assembled.

ZP Oval

ZP2 Oval

Construction

Mounting Bracket Assembly

Precautions

Dimensions/Models

Single unit **2 x 4 to 4 x 10**

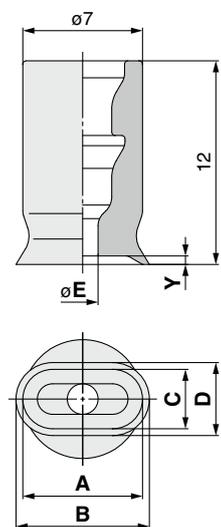

ZP **2004** U **N**
① ②

Model			A	B	C	D	E	Y
① Pad size	Form	② Material ^{*1}						
ZP	U	2004	4	4.6	2	2.6	1.2	0.3
		3507	7	7.8	3.5	4.3	1.8	0.5
		4010	10	11	4	5	2	0.8

*1 N: NBR, S: Silicone rubber, U: Urethane rubber, F: FKM, GN: Conductive NBR, GS: Conductive silicone rubber

Construction p. 185
Mounting Bracket Assembly From p. 189

With adapter **2 x 4 to 4 x 10**

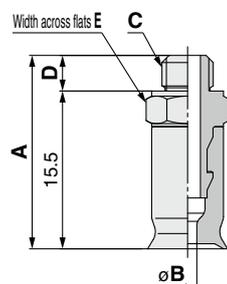

ZP **T** **2004** U **N** - **A5**
① ② ③ ④

① Adapter material

Nil	Brass
S	Stainless steel (Stainless steel 304)

④ Vacuum inlet (Male thread)

A5	M5 x 0.8
A6	M6 x 1

Construction p. 185
Adapter Assembly p. 189

Model						A	B	C	D	E
① Adapter material	Vacuum inlet direction	② Pad size	Form	③ Material ^{*1}	④ Vacuum inlet					
ZP	Nil S	T	U	N S U F GN GS	A5	19	1.2	M5 x 0.8	3.5	7
							1.8			
							2			
					A6	20	1.2	M6 x 1	4.5	8
							1.8			
							2			

*1 N: NBR, S: Silicone rubber, U: Urethane rubber, F: FKM, GN: Conductive NBR, GS: Conductive silicone rubber

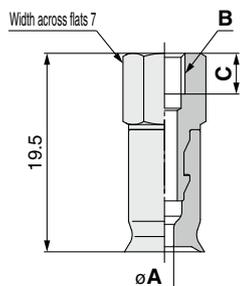

ZP **T** **2004** U **N** - **B4**
① ② ③ ④

① Adapter material

Nil	Brass
S	Stainless steel (Stainless steel 304)

④ Vacuum inlet (Female thread)

B4	M4 x 0.7
B5	M5 x 0.8

Construction p. 185
Adapter Assembly p. 189

Model						A	B	C	
① Adapter material	Vacuum inlet direction	② Pad size	Form	③ Material ^{*1}	④ Vacuum inlet				
ZP	Nil S	T	U	N S U F GN GS	B4	1.2	M4 x 0.7	4	
									1.8
									2
					B5	1.2	M5 x 0.8	5	
									1.8
									2

*1 N: NBR, S: Silicone rubber, U: Urethane rubber, F: FKM, GN: Conductive NBR, GS: Conductive silicone rubber

Dimensions/Models

With adapter/One-touch fitting 2 x 4 to 4 x 10

ZPR **2004** U **N** - **04** - **A5**

①

②

④

Connection thread
(Male thread)

Vacuum inlet
(One-touch fitting)

04	ø4
06	ø6

A5	M5 x 0.8
A6	M6 x 1

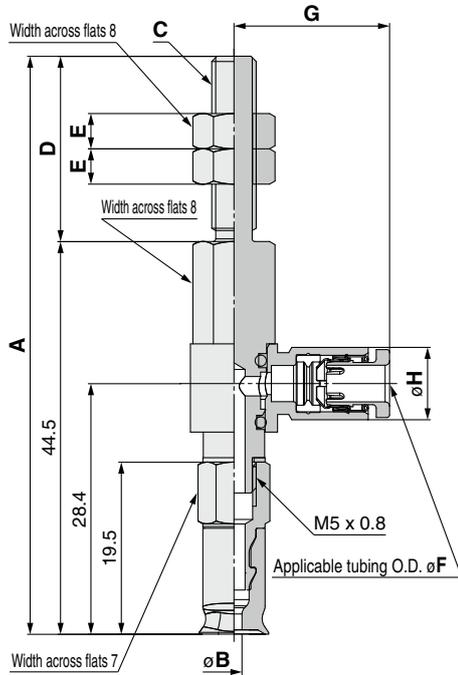

Construction	p. 185
Adapter Assembly	p. 190

Model						A	B	C	D	E
Vacuum inlet direction	① Pad size	Form	②*1 Material	③ Vacuum inlet	④ Connection thread					
ZP	R	2004	U	N S U F GN GS	04 06	A5	1.2	M5 x 0.8	21	4
		3507					1.8			
		4010					2			
		2004				A6	1.2	M6 x 1	26	4
		3507					1.8			
		4010					2			

Dimensions Per Vacuum Inlet

Model						F	G	H	Fitting part min. hole size
Vacuum inlet direction	① Pad size	Form	②*1 Material	③ Vacuum inlet	④ Connection thread				
ZP	R	2004	U	N S U F GN GS	04	4	17.5	8.2	ø2.5
		3507			A5 A6				
		4010					6	18.3	10.4

*1 N: NBR, S: Silicone rubber, U: Urethane rubber, F: FKM, GN: Conductive NBR, GS: Conductive silicone rubber

Dimensions/Models

With adapter/One-touch fitting 2 x 4 to 4 x 10

ZPR **2004** **U** **N** - **04** - **B4**

①

②

④

**Connection thread
(Female thread)**

**Vacuum inlet
(One-touch fitting)**

04	ø4
06	ø6

B4	M4 x 0.7
B5	M5 x 0.8

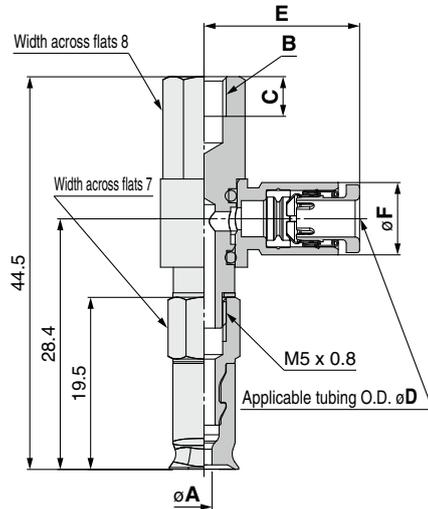

Construction	p. 185
Adapter Assembly	p. 190

		Model				A	B	C	
Vacuum inlet direction	① Pad size	Form	②*1 Material	③ Vacuum inlet	④ Connection thread				
ZP	R	2004	U	N S U F GN GS	04 06	B4	1.2	M4 x 0.7	4.5
		3507					1.8		
		4010					2		
		2004				B5	1.2	M5 x 0.8	5.5
		3507					1.8		
		4010					2		

Dimensions Per Vacuum Inlet

		Model				D	E	F	Fitting part min. hole size	
Vacuum inlet direction	① Pad size	Form	②*1 Material	③ Vacuum inlet	④ Connection thread					
ZP	R	2004	U	N S U F GN GS	04	B4 B5	4	17.5	8.2	ø2.5
		3507			06		6	18.3	10.4	ø4

*1 N: NBR, S: Silicone rubber, U: Urethane rubber, F: FKM, GN: Conductive NBR, GS: Conductive silicone rubber

Dimensions/Models

With adapter/barb fitting 2 x 4 to 4 x 10

ZPY **2004** **U** **N** - **N4** - **A5**

①

②

④

Connection thread (Male thread)

Vacuum inlet (Barb fitting)

A5	M5 x 0.8
A6	M6 x 1

N4	For ø4 nylon tubing	M-5AN-4
N6	For ø6 nylon tubing	M-5AN-6
U4	For ø4 soft tubing	M-5AU-4
U6	For ø6 soft tubing	M-5AU-6

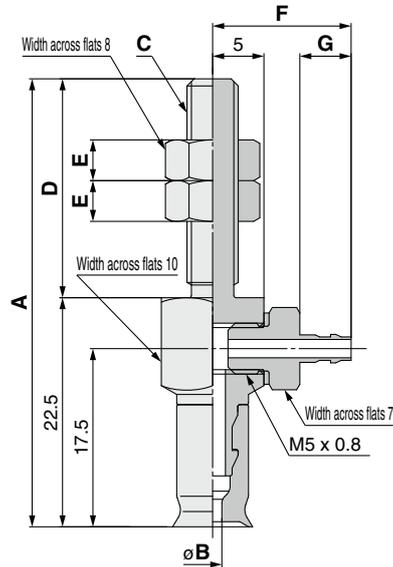

Construction	p. 185
Adapter Assembly	p. 191

		Model				A	B	C	D	E
Vacuum inlet direction	① Pad size	Form	② *1 Material	③ Vacuum inlet	④ Connection thread					
ZP	Y	U	N S U F GN GS	N4 N6 U4 U6	A5	44	1.2	M5 x 0.8	21.5	4
					A6		1.8			
				2004 3507 4010	A5	49.5	1.2	M6 x 1	27	4
							A6			

Dimensions Per Vacuum Inlet

		Model				F	G	Fitting part min. hole size
Vacuum inlet direction	① Pad size	Form	② *1 Material	③ Vacuum inlet	④ Connection thread			
ZP	Y	U	N S U F GN GS	N4 U4	A5 A6	13.5	5	ø1.8
				N6 U6				

*1 N: NBR, S: Silicone rubber, U: Urethane rubber, F: FKM, GN: Conductive NBR, GS: Conductive silicone rubber

Dimensions/Models

With adapter/barb fitting 2 x 4 to 4 x 10

ZPY **2004** U **N** - **N4** - **B4**

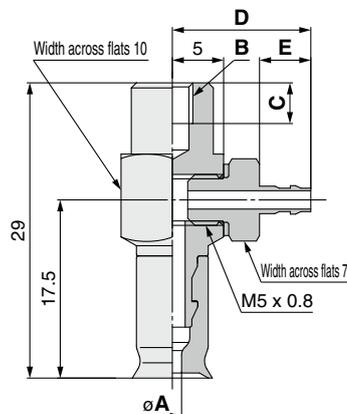

Construction p. 185
Adapter Assembly p. 191

①

②

Vacuum inlet ③
(Barb fitting)

④ Connection thread
(Female thread)

N4	For ø4 nylon tubing	M-5AN-4
N6	For ø6 nylon tubing	M-5AN-6
U4	For ø4 soft tubing	M-5AU-4
U6	For ø6 soft tubing	M-5AU-6

B4	M4 x 0.7
B5	M5 x 0.8

	Vacuum inlet direction	Model				A	B	C	
		① Pad size	Form	② ^{*1} Material	③ Vacuum inlet				④ Connection thread
ZP	Y	2004	U	N S U F GN GS	N4 N6 U4 U6	B4	1.2	M4 x 0.7	4
		3507					1.8		
		4010					2		
		2004			B5	1.2	M5 x 0.8	5	
		3507				1.8			
		4010				2			

Dimensions Per Vacuum Inlet

	Vacuum inlet direction	Model				D	E	Fitting part min. hole size	
		① Pad size	Form	② ^{*1} Material	③ Vacuum inlet				④ Connection thread
ZP	Y	2004 3507 4010	U	N S U F GN GS	N4 U4	B4 B5	13.5	5	ø1.8
		N6 U6			15.5		7	ø2.5	

*1 N: NBR, S: Silicone rubber, U: Urethane rubber, F: FKM, GN: Conductive NBR, GS: Conductive silicone rubber

Dimensions/Models

With buffer 2 x 4 to 4 x 10

The drawings show the type with a buffer plate.

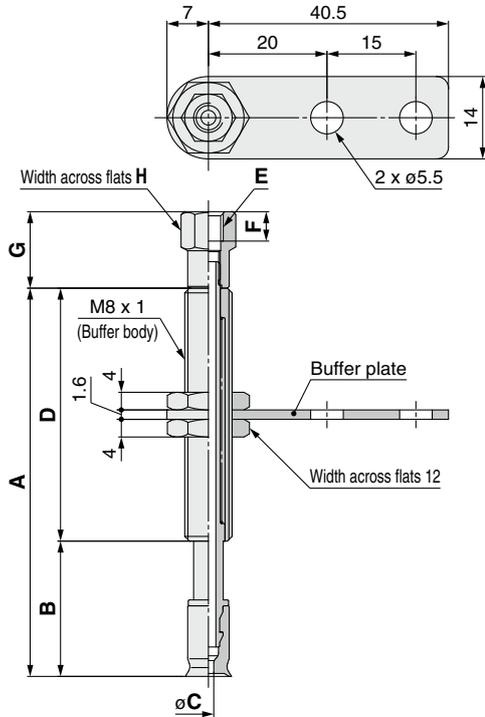

ZPT **2004** **U** **N** **J** **6** - **B3** - **A8**

Buffer specification 3

J	Rotating
K	Non-rotating
JN	Rotating (Without buffer plate)
KN	Non-rotating (Without buffer plate)

6 Connection thread (Male thread)

A8	M8 x 1
-----------	--------

5 Vacuum inlet

B3	M3 x 0.5	Female thread	
B5	M5 x 0.8	Female thread	
04	ø4	One-touch fitting	KQ2H04-M5N
06	ø6	One-touch fitting	KQ2H06-M5N
N4	For ø4 nylon tubing	Barb fitting	
U4	For ø4 soft tubing	Barb fitting	

		Model						A	B	C	D						
Vacuum inlet direction	1 Pad size	Form	2*1 Material	3 Buffer spec.	4 Buffer stroke	5 Vacuum inlet	6 Connection thread										
ZP	T	U	N S U F GN GS	J K JN KN	6	B3 B5 04 06 N4 U4	A8	33	18	1.2	15						
					10			66	23		43						
					15			71	28								
											25			81	38		
											6			33	18	1.8	15
											10			66	23		43
					15			71	28								
					25			81	38								
					6			33	18	2	15						
					10			66	23		43						
					15			71	28								
					25			81	38								

Vacuum inlet: One-touch fitting

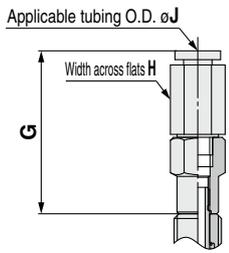

Dimensions Per Vacuum Inlet: Female Thread

		Model						E	F	G	H
Vacuum inlet direction	1 Pad size	Form	2*1 Material	3 Buffer spec.	4 Buffer stroke	5 Vacuum inlet	6 Connection thread				
ZP	T	U	N S U F GN GS	J K JN KN	6	B3 B5	A8	M3 x 0.5	3	11	6
					10			M5 x 0.8	5	13	8
					15						
				25							

Vacuum inlet: Barb fitting

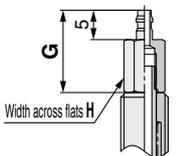

Dimensions Per Vacuum Inlet: One-touch Fitting

		Model						G	H	J	Fitting part min. hole size
Vacuum inlet direction	1 Pad size	Form	2*1 Material	3 Buffer spec.	4 Buffer stroke	5 Vacuum inlet	6 Connection thread				
ZP	T	U	N S U F GN GS	J K JN KN	6	04 06	A8	27.7	8	4	ø2.5
					10				10	6	
					15						
				25							

- Construction p. 186
- Buffer Assembly p. 192

Dimensions Per Vacuum Inlet: Barb Fitting

		Model						G	H	Fitting part min. hole size
Vacuum inlet direction	1 Pad size	Form	2*1 Material	3 Buffer spec.	4 Buffer stroke	5 Vacuum inlet	6 Connection thread			
ZP	T	U	N S U F GN GS	J K JN KN	6	N4 U4	A8	14	6	ø1.8
					10					
					15					
				25						

*1 N: NBR, S: Silicone rubber, U: Urethane rubber, F: FKM, GN: Conductive NBR, GS: Conductive silicone rubber

Dimensions/Models

With buffer/One-touch fitting 2 x 4 to 4 x 10

The drawings show the type with a buffer plate.

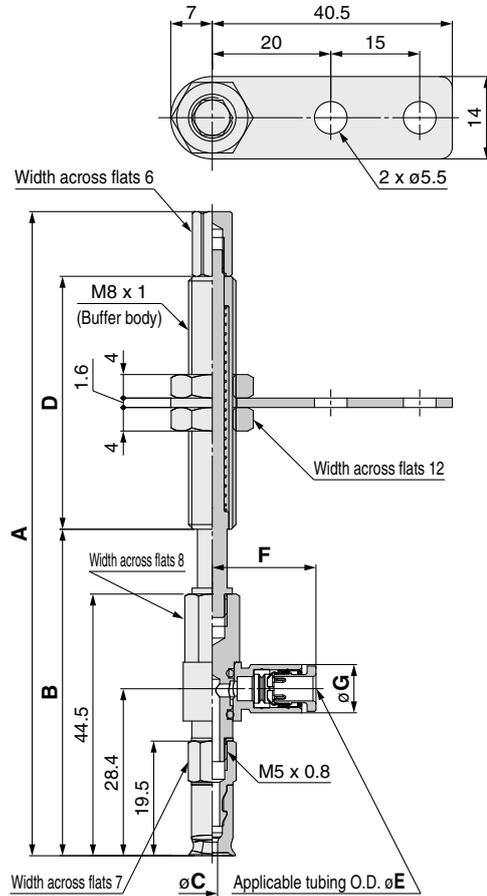

Construction p. 186
Buffer Assembly p. 193

ZPR **2004** **U** **N** **J** **6** - **04** - **A8**

1	2	3	4	5	6
Buffer specification			Connection thread (Male thread)		
J	Rotating		A8 M8 x 1		
K	Non-rotating				
JN	Rotating (Without buffer plate)		5 Vacuum inlet (One-touch fitting)		
KN	Non-rotating (Without buffer plate)				
04	ø4				
06	ø6				

	Vacuum inlet direction	Model						A	B	C	D		
		1 Pad size	Form	2 *1 Material	3 Buffer spec.	4 Buffer stroke	5 Vacuum inlet					6 Connection thread	
ZP	R	2004	U	N S U F GN GS	J K JN KN	6	04	A8	78.5	52.5	1.2	15	
						10			109.5	55.5		43	
						15			114.5	60.5			
		25			124.5	70.5							
		6			78.5	52.5			1.8	15			
		10			109.5	55.5				43			
	15	114.5	60.5										
	25	124.5	70.5										
	R	3507	U		N S U F GN GS	J K JN KN	6	06	A8	78.5	52.5	2	15
							10			109.5	55.5		43
							15			114.5	60.5		
		25				124.5	70.5						
6		78.5		52.5		2	15						
10		109.5		55.5			43						
15	114.5	60.5											
25	124.5	70.5											

Dimensions Per Vacuum Inlet

	Vacuum inlet direction	Model						E	F	G	Fitting part min. hole size	
		1 Pad size	Form	2 *1 Material	3 Buffer spec.	4 Buffer stroke	5 Vacuum inlet					6 Connection thread
ZP	R	2004 3507 4010	U	N S U F GN GS	J K JN KN	6	04	A8	4	17.5	8.2	ø2.5
						10 15 25			06	6	18.3	10.4

*1 N: NBR, S: Silicone rubber, U: Urethane rubber, F: FKM, GN: Conductive NBR, GS: Conductive silicone rubber

Dimensions/Models

With buffer/barb fitting 2 x 4 to 4 x 10

The drawings show the type with a buffer plate.

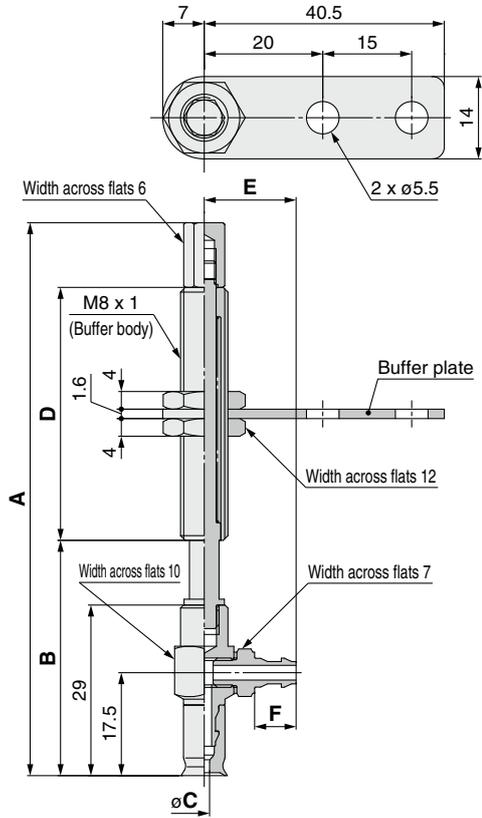

Construction p. 186
Buffer Assembly p. 194

ZPY **2004** **U** **N** **J** **6** - **N4** - **A8**

① ② ③ ④ ⑤ ⑥

Buffer specification ③

J	Rotating
K	Non-rotating
JN	Rotating (Without buffer plate)
KN	Non-rotating (Without buffer plate)

⑥ Connection thread (Male thread)

A8	M8 x 1
-----------	--------

⑤ Vacuum inlet (Barb fitting)

N4	For ø4 nylon tubing	M-5AN-4
N6	For ø6 nylon tubing	M-5AN-6
U4	For ø4 soft tubing	M-5AU-4
U6	For ø6 soft tubing	M-5AU-6

		Model						A	B	C	D								
Vacuum inlet direction	① Pad size	Form	② *1 Material	③ Buffer spec.	④ Buffer stroke	⑤ Vacuum inlet	⑥ Connection thread												
ZP	Y	2004	U	N S U F GN GS	J K JN KN	6	N4 N6 U4 U6	A8	63	37	1.2	15							
						10			94	40		43							
						15			99	45		43							
												25				109	55		
												6				63	37	1.8	15
												10				94	40		43
					15				99	45	43								
					25				109	55									
					6				63	37	2	15							
					10				94	40		43							
					15				99	45		43							
					25				109	55									

Dimensions Per Vacuum Inlet

		Model						E	F	Fitting part min. hole size	
Vacuum inlet direction	① Pad size	Form	② *1 Material	③ Buffer spec.	④ Buffer stroke	⑤ Vacuum inlet	⑥ Connection thread				
ZP	Y	2004 3507 4010	U	N S U F GN GS	J K JN KN	6	N4 U4	A8	13.5	5	ø1.8
						10 15 25			N6 U6	15.5	7

*1 N: NBR, S: Silicone rubber, U: Urethane rubber, F: FKM, GN: Conductive NBR, GS: Conductive silicone rubber



Oval Pad

Oval Flat Type

ZP2 Series



How to Order

	Pad unit	Dimensions/Models	Construction	Mounting Bracket Assembly
	ZP2- 35 07 W N	p. 180	p. 187	From p. 195
	ZP2- T 35 07 W N - B5 - []	From p. 180	p. 187	p. 195
	ZP2- T 35 07 W N K 10 - B5	From p. 183	p. 188	From p. 196

①
②
③
④
⑤
⑥
⑦

• Oval flat type • • Buffer specification: Non-rotating •

① Vacuum inlet direction

N	Pad unit
T	Vertical
R	Lateral

②/③ Pad size

Symbol	③ Length			
	07	10	20	30
② Breadth	35 (3.5 x 7)	—	—	—
	40	(4 x 10)	(4 x 20)	(4 x 30)
	50	(5 x 10)	(5 x 20)	(5 x 30)
	60	(6 x 10)	(6 x 20)	(6 x 30)
	80	—	(8 x 20)	(8 x 30)

④ Material

N	NBR
S	Silicone rubber*1
U	Urethane rubber
F	FKM
GN	Conductive NBR
GS	Conductive silicone rubber

*1 Compliant with the FDA (USA Food and Drug Administration) regulation 21CFR§177.2600 for "Rubber articles intended for repeated use"

⑤ Buffer stroke

Stroke [mm]	Pad size	
	All sizes	
10	●	
20	●	
30	●	
40	●	
50	●	

With adapter

⑥ Vacuum inlet/⑦ Connection thread

○: ZP2-T/Vertical ●: ZP2-R/Lateral

⑥ Vacuum inlet			⑦ Connection thread			Pad size
Type	Symbol	Size	Type	Symbol	Size	All sizes
Female thread	B5	M5 x 0.8	—	Nil	—*1	○
One-touch fitting	04	ø4	Male thread	A5	M5 x 0.8	●
			Female thread	B5	M5 x 0.8	●
	06	ø6	Male thread	A5	M5 x 0.8	●
			Female thread	B5	M5 x 0.8	●

*1 Use the vacuum inlet.

With buffer

⑥ Vacuum inlet/⑦ Connection thread

○: ZP2-T/Vertical ●: ZP2-R/Lateral

⑥ Vacuum inlet			⑦ Connection thread			Pad size
Type	Symbol	Size	Type	Symbol	Size	All sizes
Female thread	B5	M5 x 0.8	Male thread	Nil	M10 x 1	○
One-touch fitting	04	ø4		Nil		○●
	06	ø6		Nil		○●

* The pad, mounting nut, and fitting are shipped together but do not come assembled.

Dimensions/Models

Single unit **3.5 x 7 to 8 x 30**

ZP2 - **3507** W **N**
① ②

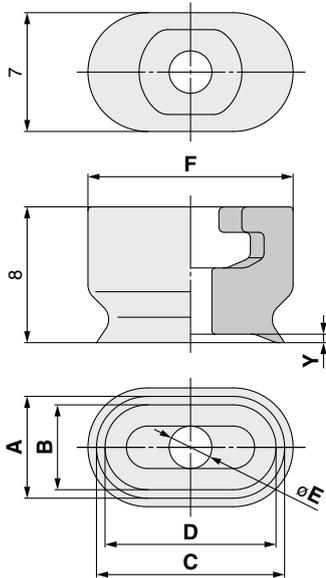

Model	① Pad size		Form	② Material	A	B	C	D	E	F	Y
	Breadth	Length									
	ZP2	35									
40		10	4.8	4	10.8	10	2.5				
50		10	6	5	11			20	2 x 1.8		
60		10	7	6		20.8	2 x 2			20	
40		20	4.8	4	21			2.5	3		
50		20	6	5		30.8	2 x 1.8			30	
60		20	7	6	31			2 x 2.5	0.8		
80		20	9	8		30	0.5				
40		30	4.8	4	30			0.8			
50		30	6	5		31	0.5				
60		30	7	6	31			0.8			
80		30	9	8		31	0.8				

*1 N: NBR, S: Silicone rubber, U: Urethane rubber, F: FKM, GN: Conductive NBR, GS: Conductive silicone rubber

Construction p. 187

Mounting Bracket Assembly From p. 195

With adapter **3.5 x 7 to 8 x 30**

ZP2 - T **3507** W **N** - **B5**
① ② ③

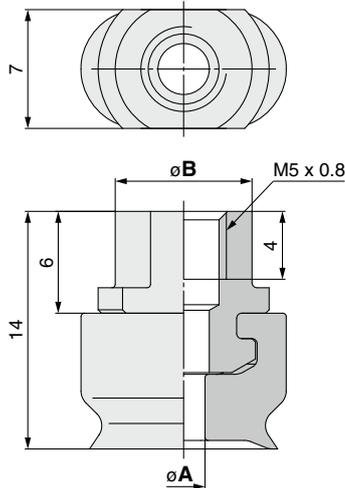

③ Vacuum inlet (Female thread)

B5 M5 x 0.8

Model	Vacuum inlet direction	① Pad size		Form	② Material	③ Vacuum inlet	A	B		
		Breadth	Length							
		ZP2	T						W	N S U F GN GS
40	10			2.5						
50	10			2 x 1.8	11					
60	10					2 x 2				
40	20			2.5	11					
50	20			3						
60	20			2 x 1.8	19					
80	20			2 x 2.5						
40	30			2 x 1.8	19					
50	30					2 x 2.5				
60	30			2 x 2.5	19					
80	30					2 x 2.5				

*1 N: NBR, S: Silicone rubber, U: Urethane rubber, F: FKM, GN: Conductive NBR, GS: Conductive silicone rubber

Construction p. 187

Adapter Assembly p. 195

Dimensions/Models

With adapter/One-touch fitting 3.5 x 7 to 8 x 30

ZP2 - R **3507** W **N** - **04** - **A5**

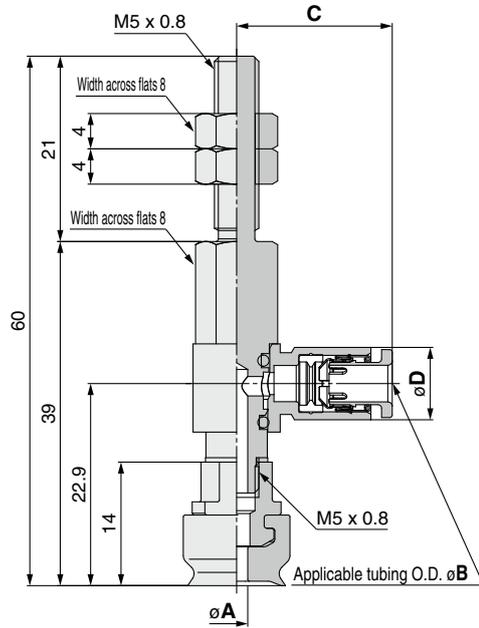

1	2	3	4 Connection thread (Male thread)
04	$\phi 4$	06	$\phi 6$
		A5	M5 x 0.8

Construction	p. 187
Adapter Assembly	p. 195

Model						A		
Vacuum inlet direction	1 Pad size		2 Form	3 Vacuum inlet	4 Connection thread			
	Breadth	Length		*1 Material				
ZP2	R	35	07	W	N S U F GN GS	04 06	A5	2 x 1.5
		40						2.5
		50	10					2 x 1.8
		60						2 x 2
		40	20					2.5
		50						3
	60		2 x 1.8					
	80							
	40	30	2 x 1.8					
	50							
	60		2 x 2.5					
	80							

Dimensions Per Vacuum Inlet

Model						B	C	D	Fitting part min. hole size		
Vacuum inlet direction	1 Pad size		2 Form	3 Vacuum inlet	4 Connection thread						
	Breadth	Length		*1 Material							
ZP2	R	35	07	W	N S U F GN GS	04 06	A5	4	17.5	8.2	$\phi 2.5$
								6	18.3	10.4	$\phi 4$
		40	10					4	17.5	8.2	$\phi 2.5$
								6	18.3	10.4	$\phi 4$
		50	20					4	17.5	8.2	$\phi 2.5$
								6	18.3	10.4	$\phi 4$
	60		4					17.5	8.2	$\phi 2.5$	
			6					18.3	10.4	$\phi 4$	
	80		4					17.5	8.2	$\phi 2.5$	
			6					18.3	10.4	$\phi 4$	

*1 N: NBR, S: Silicone rubber, U: Urethane rubber, F: FKM, GN: Conductive NBR, GS: Conductive silicone rubber

Dimensions/Models

With adapter/One-touch fitting 3.5 x 7 to 8 x 30

ZP2 - R **3507** W **N** - **04** - **B5**

①

②

④

Connection thread (Female thread)

B5 M5 x 0.8

Vacuum inlet (One-touch fitting)

04	ø4
06	ø6

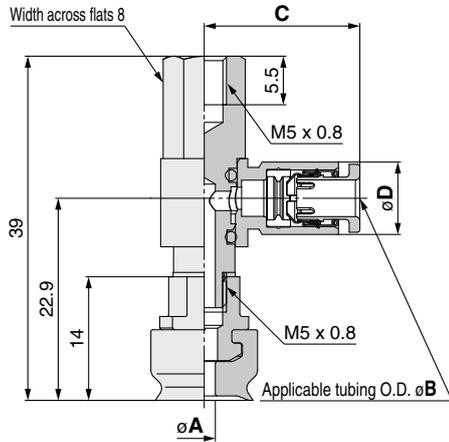

Construction p. 187
Adapter Assembly p. 195

Model							A		
Vacuum inlet direction	① Pad size Breadth Length		② Form	③ Material	④ Vacuum inlet	⑤ Connection thread			
ZP2	R	35	07	W	N S U F GN GS	04	B5	2 x 1.5	
		40	10						2.5
		50							2 x 1.8
		60							2 x 2
		80	2.5						
		40	20						3
	60	2 x 1.8							
	80	2 x 2.5							

Dimensions Per Vacuum Inlet

Model							B	C	D	Fitting part min. hole size	
Vacuum inlet direction	① Pad size Breadth Length		② Form	③ Material	④ Vacuum inlet	⑤ Connection thread					
ZP2	R	35	07	W	N S U F GN GS	04	B5	4	17.5	8.2	ø2.5
						06		6	18.3	10.4	ø4
		40	10			04		4	17.5	8.2	ø2.5
						06		6	18.3	10.4	ø4
						04		4	17.5	8.2	ø2.5
		60	20			06		6	18.3	10.4	ø4
	80	04		4		17.5	8.2	ø2.5			
	06			6		18.3	10.4	ø4			
	80	30	04	4		17.5	8.2	ø2.5			
				06		6	18.3	10.4	ø4		
						04	4	17.5	8.2	ø2.5	
				06		6	18.3	10.4	ø4		

*1 N: NBR, S: Silicone rubber, U: Urethane rubber, F: FKM, GN: Conductive NBR, GS: Conductive silicone rubber

Dimensions/Models

With buffer 3.5 x 7 to 8 x 30

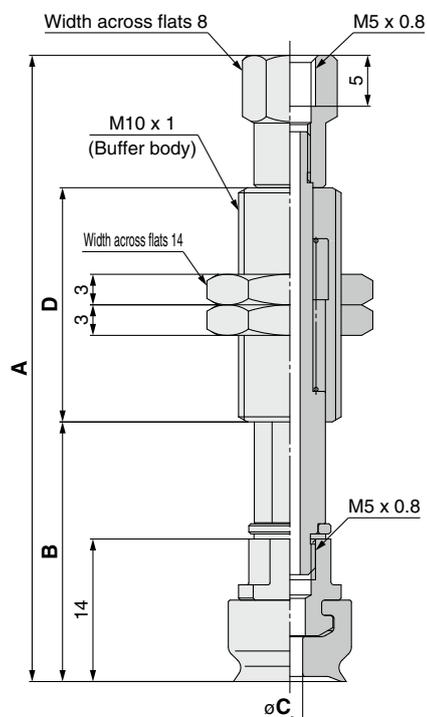

Vacuum inlet: One-touch fitting

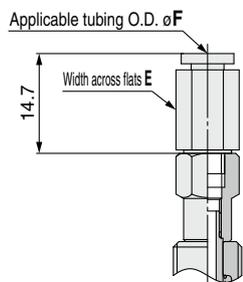

Construction p. 188
Buffer Assembly p. 196

Dimensions Per Vacuum Inlet: One-touch Fitting

		Model					E	F	Fitting part min. hole size		
Vacuum inlet direction	Pad size ① Breadth Length	Form ②	Material ③	Buffer spec. ④	Buffer stroke ⑤						
ZP2	T	35 07	W	N S U F GN GS	K	10 20 30 40 50	04	8	4	ø2.5	
							06	10	6		
		40					04	8	4		
							06	10	6		
							50 60	04	8		4
								06	10		6
	20	40					04	8	4		
							06	10	6		
		50 60 80					04	8	4		
							06	10	6		
							30	04	8		4
								06	10		6

ZP2 - T 3507 W N K 10 - B5

① ② ④
Buffer specification ③
K Non-rotating

Vacuum inlet ⑤

B5	M5 x 0.8	Female thread	
04	ø4	One-touch fitting	KQ2H04-M5N
06	ø6		KQ2H06-M5N

Vacuum inlet direction	Pad size ①		Form ②	Material ③	Buffer spec. ④	Buffer stroke ④	Vacuum inlet ⑤	A	B	C	D					
	Breadth	Length														
ZP2	T	35	07	W	N S U F GN GS	K	B5					10	61.5	25.5	2 x 1.5	23
												20	99.5	35.5		51
												30	109.5	45.5		77
												40	145.5	55.5		
												50	155.5	65.5		
												10	61.5	25.5		2 x 1.5
		20	99.5									35.5	51			
		30	109.5									45.5	77			
		40	145.5									55.5				
		50	155.5									65.5				
		10	61.5									25.5	2.5	23		
		20	99.5									35.5		51		
		30	109.5									45.5		77		
		40	145.5									55.5				
		50	155.5									65.5				
		10	61.5									25.5		2 x 1.8	23	
		20	99.5									35.5	51			
		30	109.5									45.5	77			
		40	145.5									55.5				
		50	155.5									65.5				
		10	61.5									25.5	2 x 2		23	
		20	99.5									35.5		51		
		30	109.5									45.5		77		
		40	145.5									55.5				
		50	155.5									65.5				
		10	61.5									25.5		2.5	23	
		20	99.5									35.5	51			
		30	109.5									45.5	77			
		40	145.5									55.5				
		50	155.5									65.5				
		10	61.5									25.5	3		23	
		20	99.5									35.5		51		
		30	109.5									45.5		77		
		40	145.5									55.5				
		50	155.5									65.5				
		10	61.5									25.5		2 x 1.8	23	
		20	99.5									35.5	51			
		30	109.5									45.5	77			
		40	145.5									55.5				
		50	155.5									65.5				
		10	61.5									25.5	2 x 2.5		23	
		20	99.5									35.5		51		
		30	109.5									45.5		77		
		40	145.5									55.5				
		50	155.5									65.5				

*1 N: NBR, S: Silicone rubber, U: Urethane rubber, F: FKM, GN: Conductive NBR, GS: Conductive silicone rubber

Oval Pad *ZP Series* Construction

With adapter Oval flat type: 2004/3507/4010

Vacuum inlet direction **Vertical** T Type/ZP□T

ZP□T□-(A5/A6)

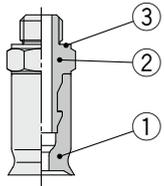

ZP□T□-(B4/B5)

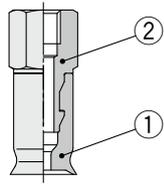

Component Parts

No.	Description	Material	Note
1	Pad	NBR, Silicone rubber, Urethane rubber, FKM, Conductive NBR, Conductive silicone rubber	Oval flat type
2	Adapter	Brass (Electroless nickel plating)	ZPT
		Stainless steel	ZPST
3	Gasket	Stainless steel/NBR	ZPT
		Stainless steel/FKM	ZPST

Vacuum inlet direction **Lateral** R Type/ZPR

ZPR□-(04/06)-(A5/A6)

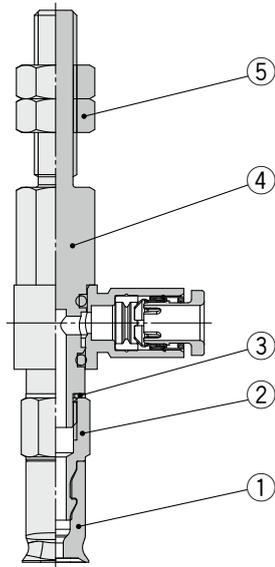

ZPR□-(04/06)-(B4/B5)

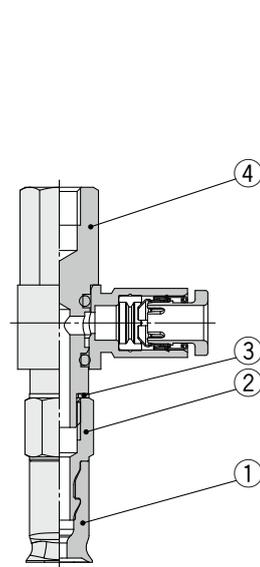

Component Parts

No.	Description	Material	Note
1	Pad	NBR, Silicone rubber, Urethane rubber, FKM, Conductive NBR, Conductive silicone rubber	Oval flat type
2	Adapter	Brass (Electroless nickel plating)	
3	Gasket	Stainless steel 304/NBR	
4	Adapter (With One-touch fitting)	Brass (Electroless nickel plating), PBT, NBR, Stainless steel, POM	
5	Nut	Rolled steel (Zinc chromated)	M5 x 0.8 M6 x 1

Vacuum inlet direction **Lateral** Y Type/ZPY

ZPY□-(N4/N6/U4/U6)-(A5/A6)

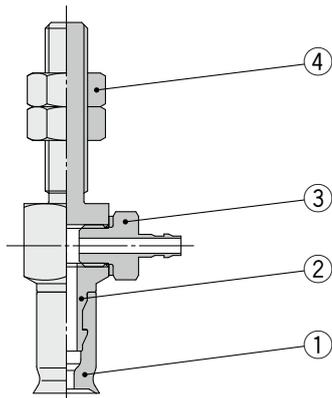

ZPY□-(N4/N6/U4/U6)-(B4/B5)

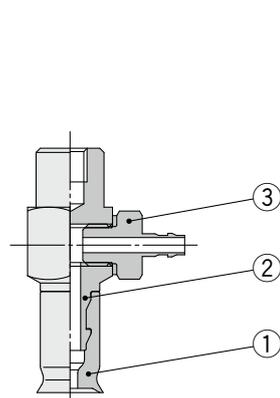

Component Parts

No.	Description	Material	Note
1	Pad	NBR, Silicone rubber, Urethane rubber, FKM, Conductive NBR, Conductive silicone rubber	Oval flat type
2	Adapter	Brass (Electroless nickel plating)	
3	Barb fitting	—	
4	Nut	Rolled steel (Zinc chromated)	M5 x 0.8 M6 x 1

With buffer Oval flat type: 2004/3507/4010

Vacuum inlet direction **Vertical** T Type/ZPT

ZPT□-(B3/B5)-A8

ZPT□-(04/06)-A8

ZPT□-(N4/U4)-A8

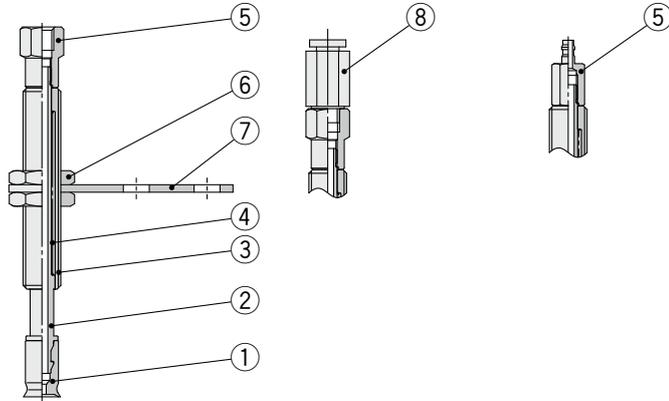

Component Parts

No.	Description	Material	Note
1	Pad	NBR, Silicone rubber, Urethane rubber, FKM, Conductive NBR, Conductive silicone rubber	Oval flat type
2	Piston rod	Stainless steel	
3	Buffer body	Brass (Electroless nickel plating)	
4	Return spring	Stainless steel	
5	Buffer adapter	Brass (Electroless nickel plating)	
6	Nut	Carbon steel (Zinc chromated)	M8 x 1
7	Buffer plate	Steel (Trivalent chromated)	
8	One-touch fitting	—	

Vacuum inlet direction **Lateral** R Type/ZPR

ZPR□-(04/06)-A8

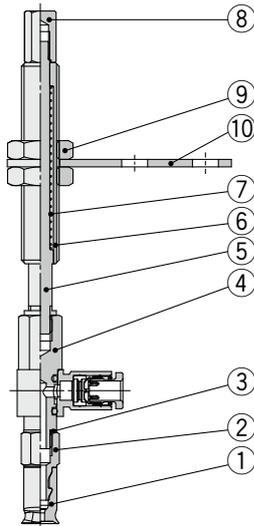

Component Parts

No.	Description	Material	Note
1	Pad	NBR, Silicone rubber, Urethane rubber, FKM, Conductive NBR, Conductive silicone rubber	Oval flat type
2	Adapter	Brass (Electroless nickel plating)	
3	Gasket	Stainless steel 304/NBR	
4	Adapter (With One-touch fitting)	Brass (Electroless nickel plating), PBT, NBR, Stainless steel, POM	
5	Piston rod	Stainless steel	
6	Buffer body	Brass (Electroless nickel plating)	
7	Return spring	Stainless steel	
8	Buffer adapter	Brass (Electroless nickel plating)	
9	Nut	Carbon steel (Zinc chromated)	M8 x 1
10	Buffer plate	Steel (Trivalent chromated)	

Vacuum inlet direction **Lateral** Y Type/ZPY

ZPY□-(N4/N6/U4/U6)-A8

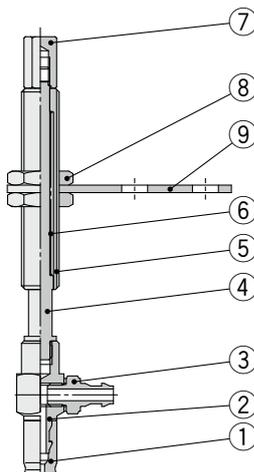

Component Parts

No.	Description	Material	Note
1	Pad	NBR, Silicone rubber, Urethane rubber, FKM, Conductive NBR, Conductive silicone rubber	Oval flat type
2	Adapter	Brass (Electroless nickel plating)	
3	Barb fitting	—	
4	Piston rod	Stainless steel	
5	Buffer body	Brass (Electroless nickel plating)	
6	Return spring	Stainless steel	
7	Buffer adapter	Brass (Electroless nickel plating)	
8	Nut	Carbon steel (Zinc chromated)	M8 x 1
9	Buffer plate	Steel (Trivalent chromated)	

Oval Pad *ZP2 Series* Construction

With adapter Oval flat type: 3507 to 8030

Vacuum inlet direction **Vertical** T Type/ZP2-T

ZP2-T□-B5

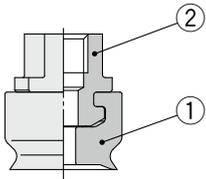

Component Parts

No.	Description	Material	Note
1	Pad	NBR, Silicone rubber, Urethane rubber, FKM, Conductive NBR, Conductive silicone rubber	Oval flat type
2	Adapter	Brass (Electroless nickel plating)	

Vacuum inlet direction **Lateral** R Type/ZP2-R

ZP2-R□-(04/06)-A5

ZP2-R□-(04/06)-B5

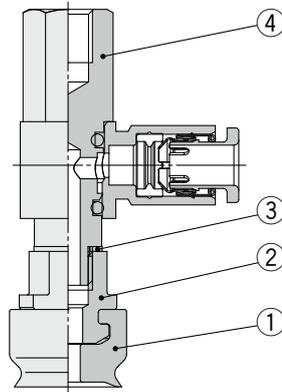
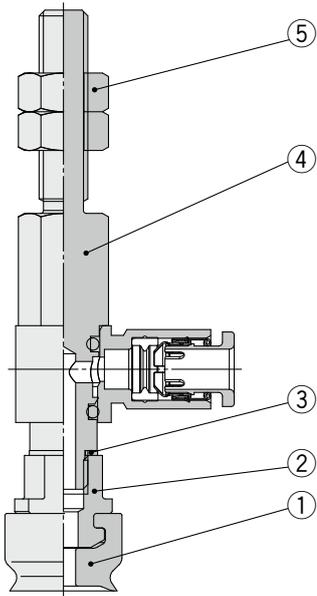

Component Parts

No.	Description	Material	Note
1	Pad	NBR, Silicone rubber, Urethane rubber, FKM, Conductive NBR, Conductive silicone rubber	Oval flat type
2	Adapter	Brass (Electroless nickel plating)	
3	Gasket	Stainless steel/NBR	
4	Adapter (With One-touch fitting)	Brass (Electroless nickel plating), PBT, NBR, Stainless steel, POM	
5	Nut	Rolled steel (Zinc chromated)	M5 x 0.8

With buffer Oval flat type: 3507 to 8030

Vacuum inlet direction **Vertical** T Type/ZP2-T

ZP2-T□-B5

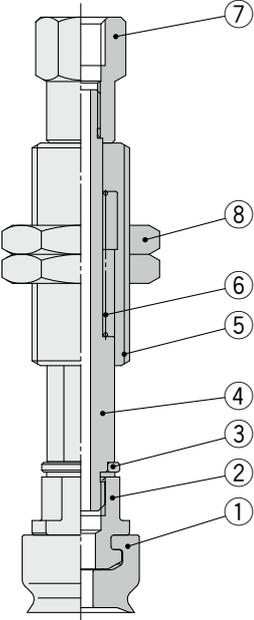

ZP2-T□-(04/06)

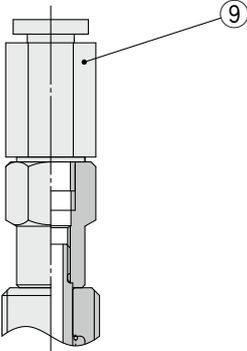

Component Parts

No.	Description	Material	Note
1	Pad	NBR, Silicone rubber, Urethane rubber, FKM, Conductive NBR, Conductive silicone rubber	Oval flat type
2	Adapter	Brass (Electroless nickel plating)	
3	Gasket	Stainless steel/NBR	
4	Piston rod	Stainless steel	
5	Buffer body	Brass (Electroless nickel plating)	
6	Return spring	Stainless steel	
7	Buffer adapter	Brass (Electroless nickel plating)	
8	Nut	Steel (Zinc chromated)	M10 x 1
9	One-touch fitting	—	

Vacuum inlet direction **Lateral** R Type/ZP2-R

ZP2-R□-(04/06)

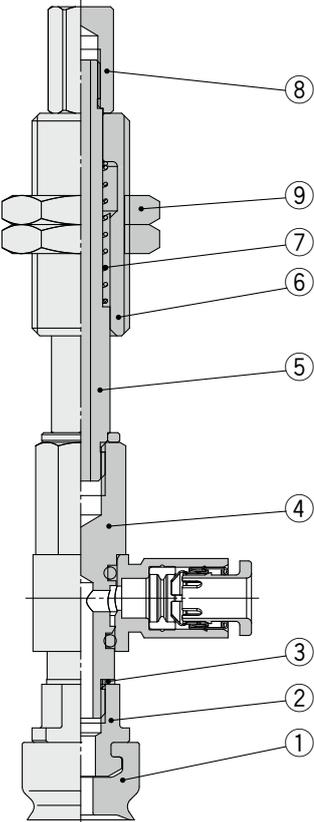

Component Parts

No.	Description	Material	Note
1	Pad	NBR, Silicone rubber, Urethane rubber, FKM, Conductive NBR, Conductive silicone rubber	Oval flat type
2	Adapter	Brass (Electroless nickel plating)	
3	Gasket	Stainless steel/NBR	
4	Adapter (With One-touch fitting)	Brass (Electroless nickel plating), PBT, NBR, Stainless steel, POM	
5	Piston rod	Stainless steel	
6	Buffer body	Brass (Electroless nickel plating)	
7	Return spring	Stainless steel	
8	Buffer adapter	Brass (Electroless nickel plating)	
9	Nut	Steel (Zinc chromated)	M10 x 1



Oval Pad Specific Product Precautions

Be sure to read this before handling the products. Refer to page 375 for safety instructions. For vacuum equipment and vacuum pad precautions, refer to pages 376 to 379.

Mounting

1. Tighten the screw within the specified torque range when mounting the buffer.

Tightening with a torque outside of the specified range may cause malfunction.

Oval Pad ZP Series

Model	Connection thread	Tightening torque [N·m]
ZP□(J/K)□-□-A8	M8 x 1	1.5 to 2.0

Oval Pad ZP2 Series

Model	Connection thread	Tightening torque [N·m]
ZP2-□K□-□	M10 x 1	2.5 to 3.5

2. Tighten the vacuum inlet male thread adapter (with a gasket seal) within the specified torque range.

Oval Pad ZP Series

Model	Connection thread	Tightening torque [N·m]
ZP□T□U□-A5	M5 x 0.8	1.3 to 1.7
ZP□T□U□-A6	M6 x 1	1.6 to 2.0