

5 Port Solenoid Valve

Metal Seal

Rubber Seal

Installation volume

42 % Reduction

Installation area

26 % Reduction

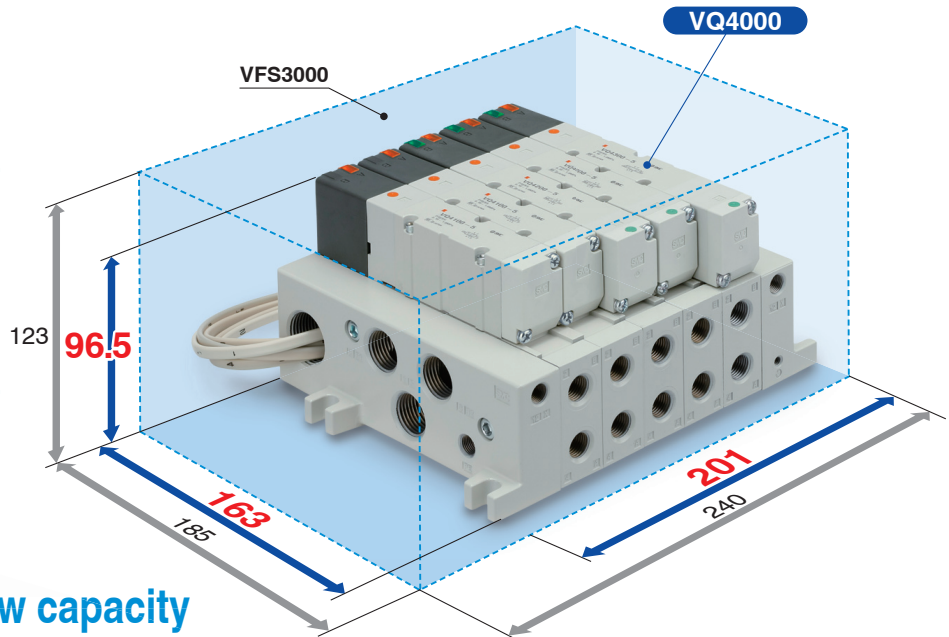

● Compact and large flow capacity

VQ4000 Possible to drive cylinders up to \varnothing 160*

VQ5000 Possible to drive cylinders up to \varnothing 180* * When the average speed is 200 mm/s. Refer to page 3 for actual conditions.



VQ4000: 25 mm pitch

Q [l/min (ANR)]: 1958*

VQ5000: 41 mm pitch

Q [l/min (ANR)]: 4350*

* 2-position single, rubber seal, 4/2 → 5/3 (A/B → R1/R2)

● Power saving

	Power consumption [W]	Maximum operating pressure [MPa]
Current product	0.5 (1.0)	0.7
VQ	0.4 (0.95)	1.0

* Low wattage type (): Standard

● Long service life

100 million cycles
(Metal seal)

* According to SMC life test conditions

● Enclosure IP65 compliant
Dust-tight/Water-jet-proof

* When manifold is IP65 compliant.
* Except F and T1 kits

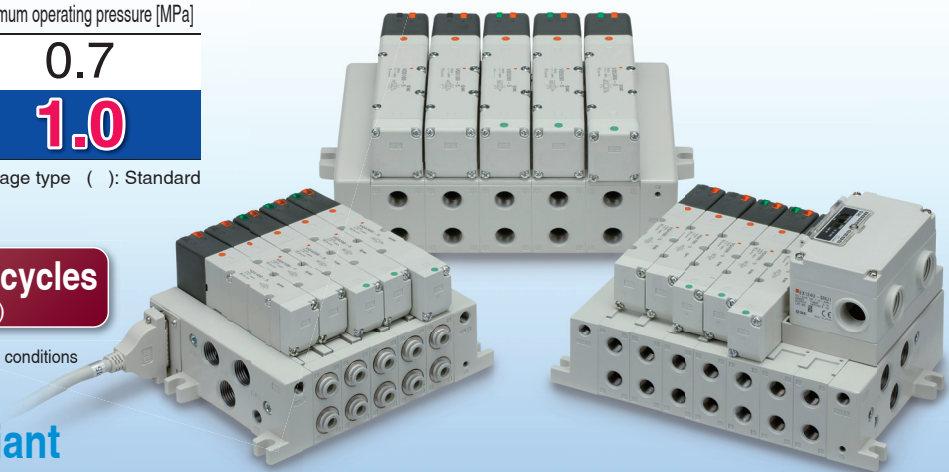

Series **VQ4000/5000**

Voltage			Electrical entry		Manual override			Semi-standard	With Control Unit	Manifold Options									
12, 24 V DC	100, 110 V AC (50/60 Hz)	200, 220 V AC (50/60 Hz)	Plug-in	Grommet	Push type/Tool required	Locking type/Tool required	Locking type/Manual	External pilot	Manifold	Blanking plate assembly	Individual SUP/EXH spacer	Restrictor spacer	SUP stop valve spacer	Release valve spacer: For D side mounting	SUP/EXH block plate	Direct exhaust with silencer box	Double check spacer with residual pressure exhaust	Manifold mounted with exhaust cleaner	Interface regulator (P, A, B port regulation)
●	● (Except S kit)	● (Except S kit)	●	●	●	●	●	● P.36	● P.37	● P.31	● P.31	● P.32	● P.32	● P.32	● P.32	● P.33	● P.33	● P.34	● P.35
●	● (Except S kit)	● (Except S kit)	●	●	●	●	●	● P.82	—	● P.77	● P.77	● P.78	● P.78	● P.78	● P.78	● P.79	● P.79	● P.80	● P.81

Manifold with Control Unit

Page 37

Air filter, regulator and equipment for controlling the air release valve pressure switch in one unit reduced piping work.

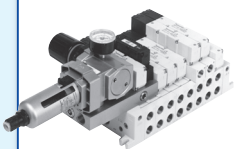

Manifold Options

Page 31 (VQ4000) Page 77 (VQ5000)

Blanking plate assembly

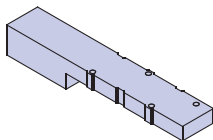

Individual SUP spacer Individual EXH spacer

<Individual SUP spacer>

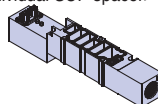

<Individual EXH spacer>

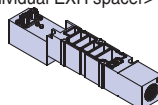

Restrictor spacer

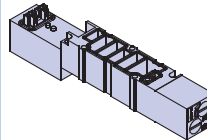

SUP stop valve spacer

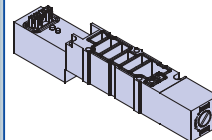

Release valve spacer: For D side mounting

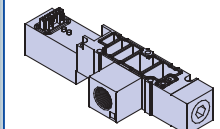

SUP/EXH block plate

<EXH block plate>

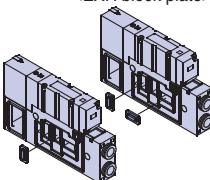

<SUP block plate>

Direct exhaust with silencer box

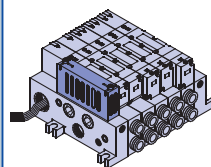

Double check spacer with residual pressure exhaust

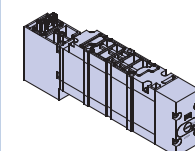

Manifold mounted with exhaust cleaner

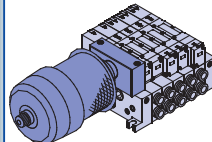

Interface regulator (P, A, B port regulation)

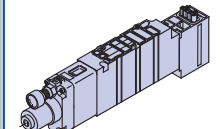

Cylinder Speed Chart

This chart is provided as guidelines only.

For performance under various conditions, use SMC's Model Selection Software before making a judgment.

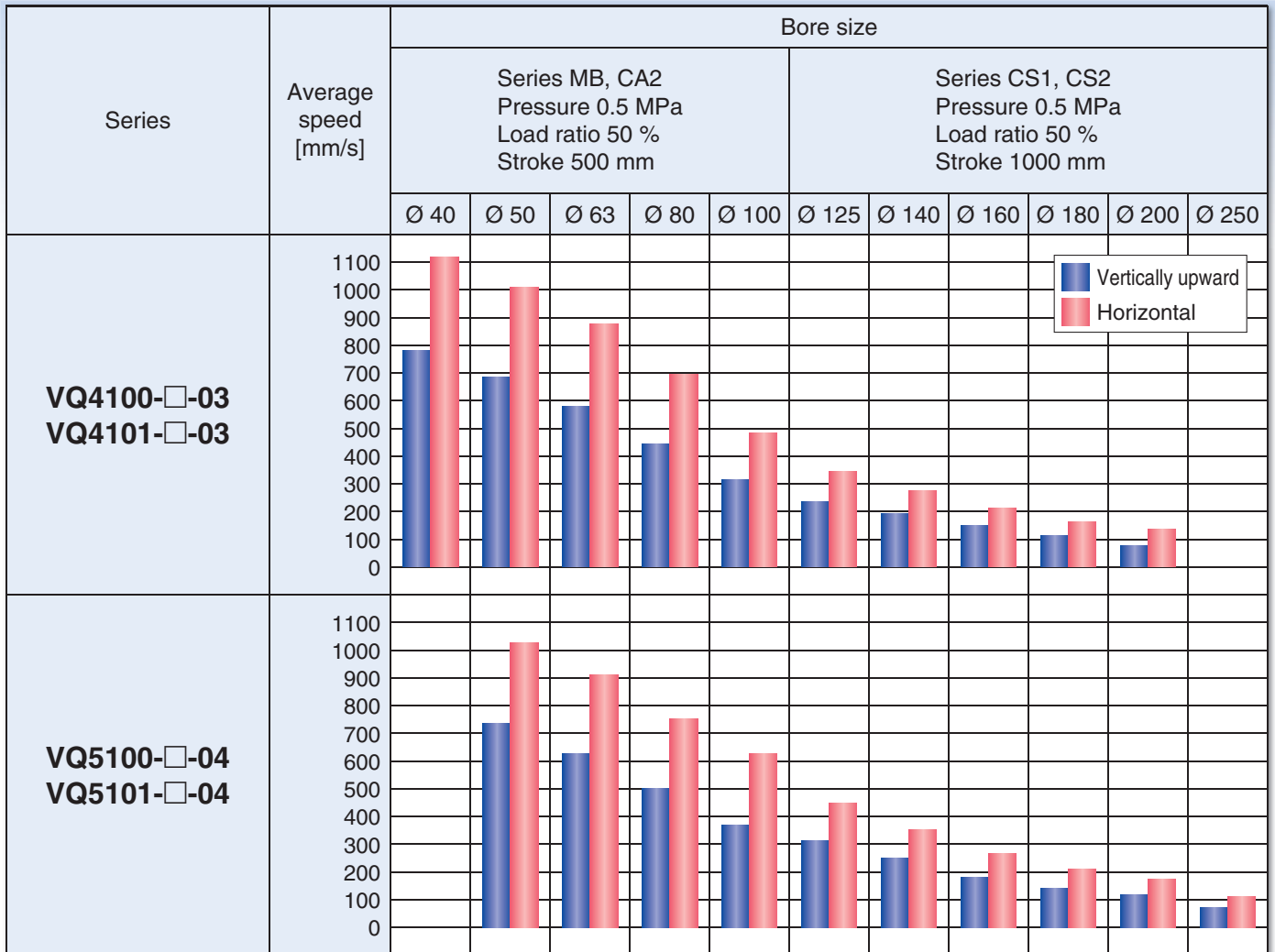

* Values at extension of a directly coupled cylinder when meter-out speed controllers are used with the needle full open.

* The average speed of the cylinder is obtained by dividing the stroke by the total stroke time.

* The load ratio is obtained by the following formula: $((\text{Load mass} \times 9.8) / \text{Theoretical output}) \times 100 \%$

Conditions

Series	Condition	Series MB, CA2	Series CS1, CS2
VQ4100-□-03 VQ4101-□-03	SGP (Steel pipe) dia. x Length	10A x 1 m	
	Speed controller	AS420-03	
	Silencer	AN30-03	
VQ5100-□-04 VQ5101-□-04	SGP (Steel pipe) dia. x Length	10A x 1 m	
	Speed controller	AS420-04	
	Silencer	AN40-04	

INDEX

Base Mounted Type Variations	Page 1
Cylinder Speed Chart	Page 3

Series VQ4000

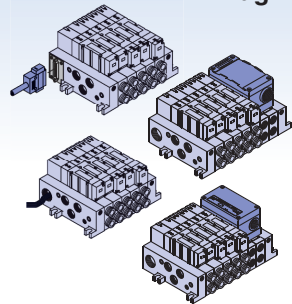

Plug-in/Plug Lead Single Unit Model, Standard Specifications	Page 5
Plug-in Unit Manifold How to Order, Specifications, Manifold Options	Page 9
F Kit (D-sub connector kit) [IP40]	Page 11
T Kit (Terminal block box kit) [IP65]	Page 15
L Kit (Lead wire cable) [IP65]	Page 19
S Kit (Serial transmission unit): EX123/124 [IP65]	Page 23
Plug Lead Unit	
C Kit (Connector kit) [IP65]	Page 27
Manifold Options	Page 31
Semi-standard Specifications	Page 36
Plug-in/Plug Lead Manifold with Control Unit	Page 37
Construction	Page 41
Exploded View of Manifold	Page 43

Series VQ5000

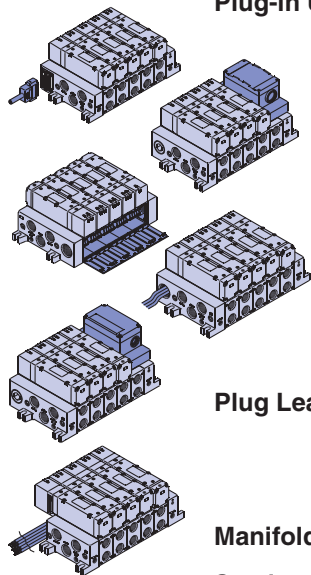

Plug-in/Plug Lead Single Unit Model, Standard Specifications	Page 47
Plug-in Unit Manifold How to Order, Specifications, Manifold Options	Page 51
F Kit (D-sub connector kit) [IP40]	Page 53
T Kit (Terminal block box kit) [IP65]	Page 57
T1 Kit (Individual terminal block kit) [IP40]	Page 61
L Kit (Lead wire cable) [IP65]	Page 65
S Kit (Serial transmission unit): EX123/124 [IP65]	Page 69
Plug Lead Unit	
C Kit (Connector kit) [IP65]	Page 73
Manifold Options	Page 77
Semi-standard Specifications	Page 82
Construction	Page 83
Exploded View of Manifold	Page 85

VQ4000/5000 Specific Product Precautions	Page 88
------------------------------------------------	---------

VQ4000

Manifold Options

Semi-standard Specifications

Manifold with Control Unit

Construction

Exploded View of Manifold

VQ5000

Manifold Options

Semi-standard Specifications

Construction

Exploded View of Manifold

Base Mounted

Plug-in/Plug Lead: Single Unit

Series VQ4000



Model

Series	Configuration	Model	Port size	Flow-rate characteristics						Response time [ms]		Weight [kg]				
				1 → 4/2 (P → A/B)			4/2 → 5/3 (A/B → EA/EB)			Standard: 0.95 W	Low wattage type: 0.4 W					
				C [dm ³ /(s·bar)]	b	Cv	Q [l/min (ANR)] Note 4)	C [dm ³ /(s·bar)]	b				Cv	Q [l/min (ANR)] Note 4)		
VQ4000	2-position	Single	Metal seal	VQ4100	3/8	6.2	0.19	1.5	1477	6.9	0.17	1.7	1625	20	22	0.23 (0.29)
			Rubber seal	VQ4101		7.2	0.43	2.1	2002	7.3	0.38	2.0	1958	25	27	
		Double	Metal seal	VQ4200		6.2	0.19	1.5	1477	6.9	0.17	1.7	1625	12	16	0.26 (0.32)
			Rubber seal	VQ4201		7.2	0.43	2.1	2002	7.3	0.38	2.0	1958	15	17	
	3-position	Closed centre	Metal seal	VQ4300		5.9	0.23	1.5	1438	6.3	0.18	1.6	1492	45	47	0.28 (0.34)
			Rubber seal	VQ4301		7.0	0.34	1.9	1827	6.4	0.42	1.9	1767	50	52	
		Exhaust centre	Metal seal	VQ4400		6.2	0.18	1.5	1469	6.9	0.17	1.7	1625	45	47	0.28 (0.34)
			Rubber seal	VQ4401		7.0	0.38	1.9	1877	7.3	0.38	2.0	1958	50	52	
		Pressure centre	Metal seal	VQ4500		6.2	0.18	1.6	1469	6.4	0.18	1.6	1516	45	47	0.28 (0.34)
			Rubber seal	VQ4501		7.0	0.38	1.9	1877	7.1	0.38	2.0	1904	50	52	
		Double check	Metal seal	VQ4600		2.7	—	—	584	3.7	—	—	800	55	57	0.50 (0.56)
			Rubber seal	VQ4601		2.8	—	—	606	3.9	—	—	844	62	64	

Note 1) Value for valve on sub-plate and cylinder port 3/8

Note 2) Based on JIS B 8375-1981. (Supply pressure: 0.5 MPa, with indicator light and surge voltage suppressor, clean air. This will change depending on pressure and air quality.) The value when ON for the double type.

Note 3) Values inside () indicate the weight of plug lead units.

Table: Without sub-plate, With sub-plate: Add 0.41 kg for plug-in type, 0.30 kg for plug lead type.

Note 4) These values have been calculated according to ISO 6358 and indicate the flow rate under standard conditions with an inlet pressure of 0.6 MPa (relative pressure) and a pressure drop of 0.1 MPa.

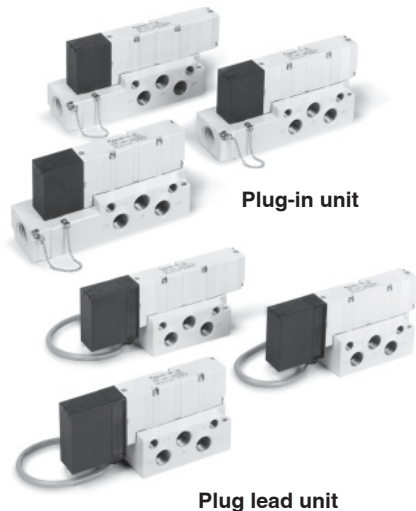

Plug-in unit

Plug lead unit

Symbol

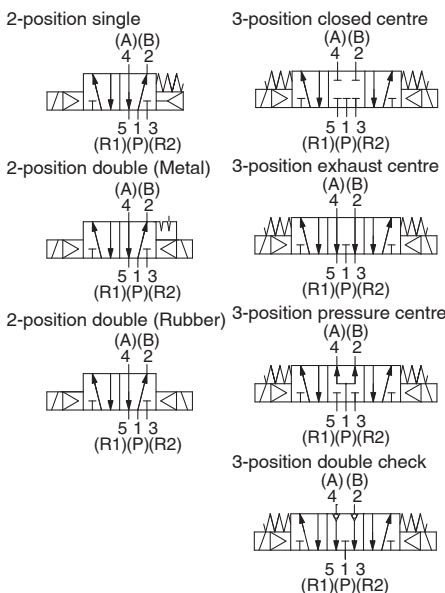

Standard Specifications

Valve specifications	Valve construction		Metal seal	Rubber seal
	Fluid		Air	
	Max. operating pressure		1.0 MPa	
	Min. operating pressure	Single	0.15 MPa	0.20 MPa
		Double	0.15 MPa	0.15 MPa
		3-position	0.15 MPa	0.20 MPa
	Ambient and fluid temperature		-10 to 50 °C ^{Note 1)}	
	Lubrication		Not required	
	Manual override		Push type/Locking type (Tool required)	
	Impact/Vibration resistance		150/30 m/s ² ^{Note 2)}	
Enclosure		Dust-tight (IP65 compatible) ^{Note 3)}		
Electrical specifications	Coil rated voltage		12, 24 VDC, 100, 110, 200, 220 VAC (50/60 Hz)	
	Allowable voltage fluctuation		±10 % of rated voltage	
	Coil insulation type		Class B or equivalent	
	Power consumption [W]	DC	Standard	0.95
Low wattage type			0.4	

Note 1) Use dry air to prevent condensation when operating at low temperatures.

Note 2) Impact resistance: No malfunction occurred when it is tested with a drop tester in the axial direction and at the right angles to the main valve and armature in both energised and de-energised states every once for each condition. (Values at the initial period)

Vibration resistance: No malfunction occurred in a one-sweep test between 45 and 2000 Hz. Test was performed at both energised and de-energised states in the axial direction and at the right angles to the main valve and armature. (Values at the initial period)

Note 3) Available only with T, L, S and C.

How to Order Valves (Single Unit)

Body

0: Plug-in sub-plate

Sub-plate

Port size

—	Without sub-plate (For manifold)
02	1/4
03	3/8

Enclosure

—	Dust-protected
W	Dust-tight/Water-jet-proof (IP65)

Thread type

—	Rc
F	G
N	NPT
T	NPTF

Plug-in VQ4 1 0 0 — 5 — — — 1 — 02 — Q

Plug lead VQ4 2 5 1 — 5 G — — — 1 — 02 — Q

Type of actuation

1	2-position single (A)(B)	3	3-position closed centre (A)(B)
	2-position double (A)(B)		3-position exhaust centre (A)(B)
2	2-position double (A)(B)	4	3-position pressure centre (A)(B)
	2-position double (A)(B)		3-position double check (A)(B)
Note) For double check type, refer to page 33.		6	

Porting specifications

—	Side ported
B	Bottom ported

Manual override

—: Non-locking push type (Tool required)	B: Locking type (Tool required)	C: Locking type (Manual)
------------------------------------------	---------------------------------	--------------------------

Light/Surge voltage suppressor

—	Yes
E	Without light, with surge voltage suppressor

Coil voltage

5	24 V DC
6	12 V DC

Electrical entry

Grommet	G	Lead wire length 0.6 m
	H	Lead wire length 1.5 m

Function

— Note 1)	Standard (0.95 W)
Y	Low wattage type (0.4 W)
R Note 2)	External pilot

Note 1) When the unit is energised continuously, refer to "Specific Product Precautions 1" on page 88.
 Note 2) For details about external pilot specifications, refer to page 36. Combination of external pilot and perfect interface is not possible.
 Note 3) When multiple symbols are specified, indicate them alphabetically.

Seal

0	Metal seal
1	Rubber seal

Body

5: Plug lead sub-plate

Sub-plate

VQ4000
 Manifold Options
 Semi-standard Specifications
 Manifold with Control Unit
 Construction
 Exploded View of Manifold

VQ5000
 Manifold Options
 Semi-standard Specifications
 Construction
 Exploded View of Manifold

How to Order Sub-plates

VQ4000 - P — — 02 — Q

Electrical entry

P	Plug-in conduit terminal
S	Plug lead

Thread type

—	Rc
F	G
N	NPT
T	NPTF

Port size

02	1/4
03	3/8

Enclosure

—	Dust-protected
W Note)	Dust-tight/Water-jet-proof

Note) Not required for plug lead type.

Porting specifications

—	Side ported
B	Bottom ported Note)

Replacement of pilot valve assembly (Voltage)

Refer to pages 41 and 42 for pilot valve assembly part numbers.
 Refer to page 89 for replacement method.

Series VQ4000

Dimensions: Plug-in Type

Conduit terminal

2-position single: VQ410⁰-□

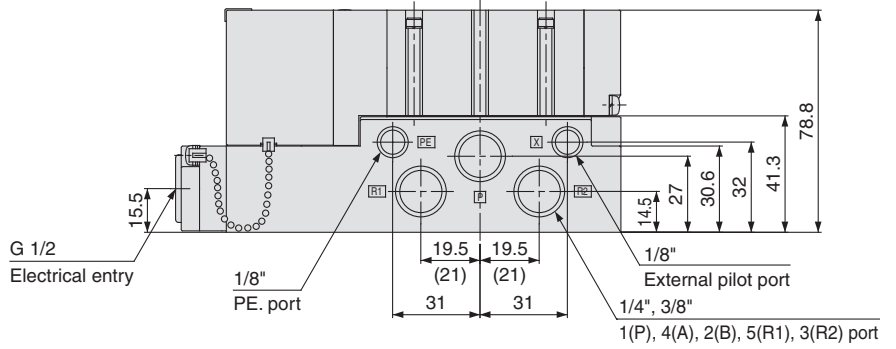
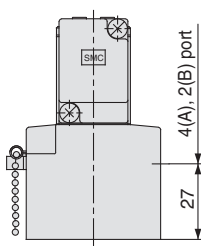

Bottom ported drawing

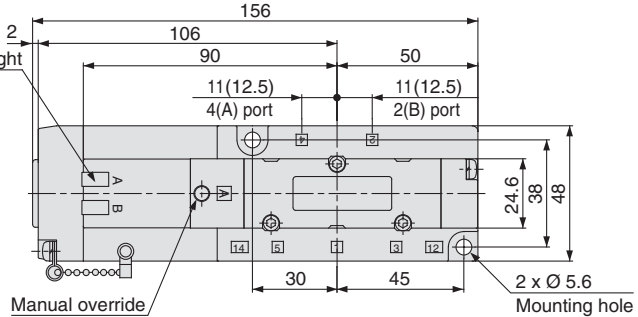
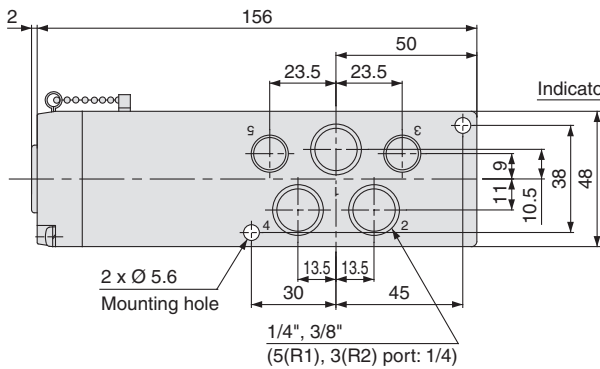

(): Values for 3/8"

- 2-position double: VQ420⁰-□
- 3-position closed centre: VQ430⁰-□
- 3-position exhaust centre: VQ440⁰-□
- 3-position pressure centre: VQ450⁰-□

3-position double check: VQ460⁰-□

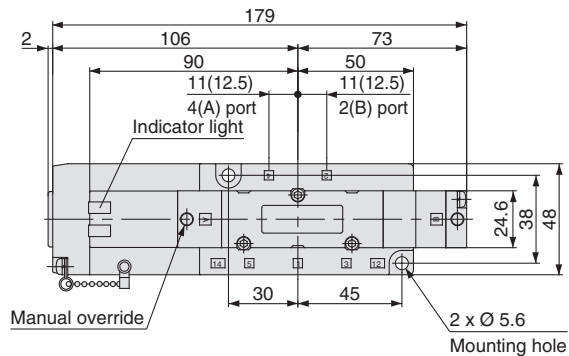
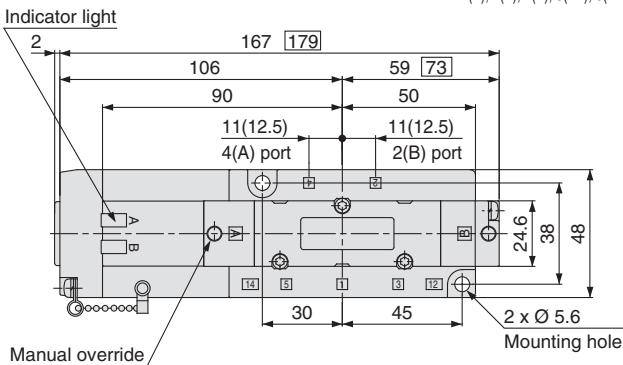
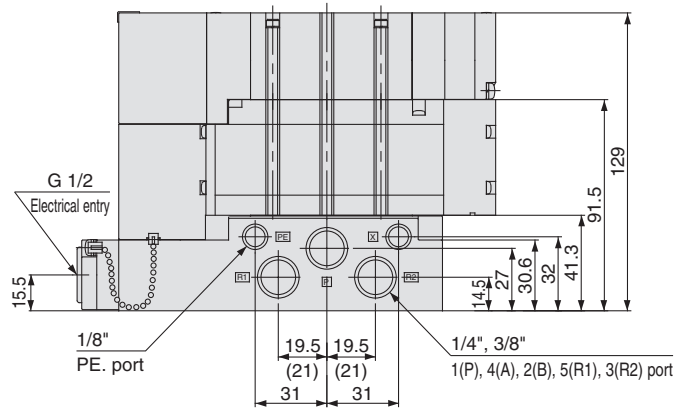
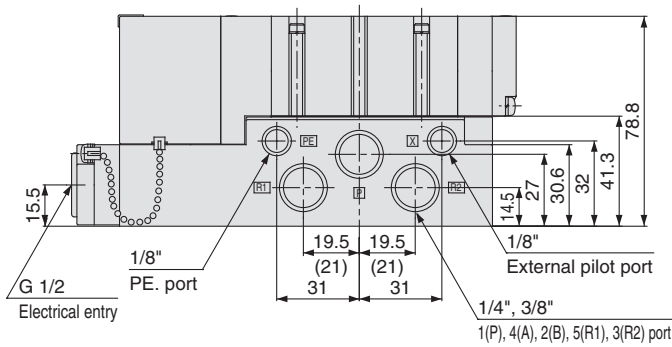

□: Values for 3-position
(): Values for 3/8"

Dimensions: Plug Lead Type

Grommet

2-position single: VQ415⁰₁-□^G_H

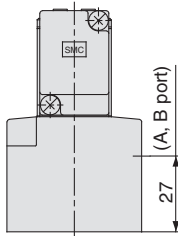

Bottom ported drawing

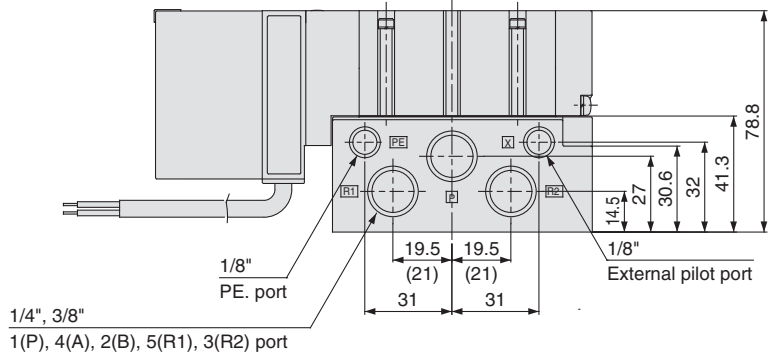
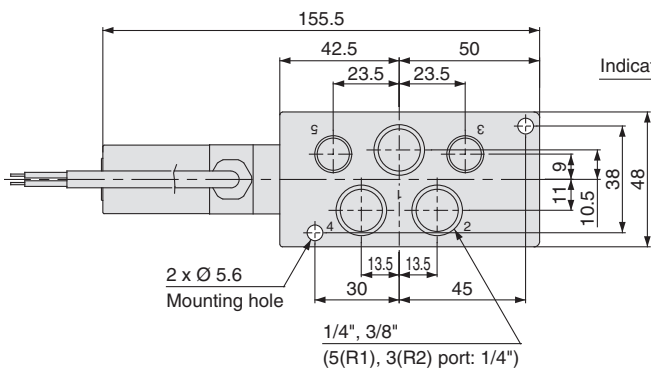

1/4", 3/8"
 1(P), 4(A), 2(B), 5(R1), 3(R2) port

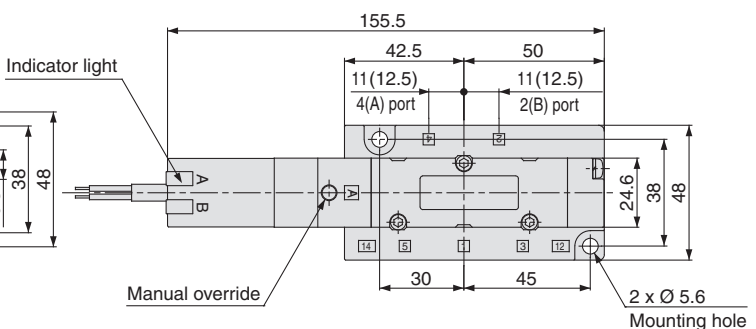

(): Values for 3/8"

2-position double: VQ425⁰₁-□^G_H
 3-position closed centre: VQ435⁰₁-□^G_H
 3-position exhaust centre: VQ445⁰₁-□^G_H
 3-position pressure centre: VQ455⁰₁-□^G_H

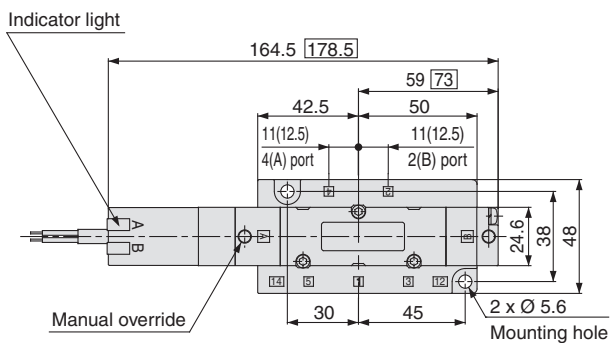
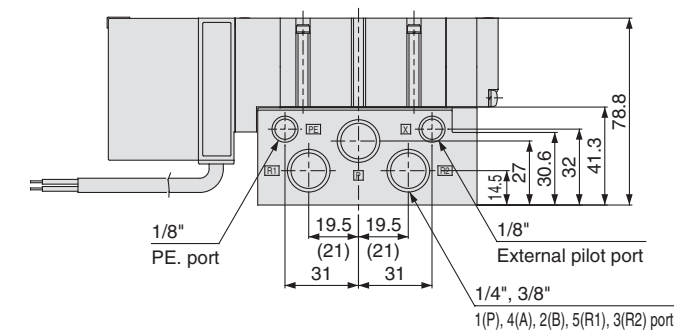

3-position double check: VQ465⁰₁-□^G_H

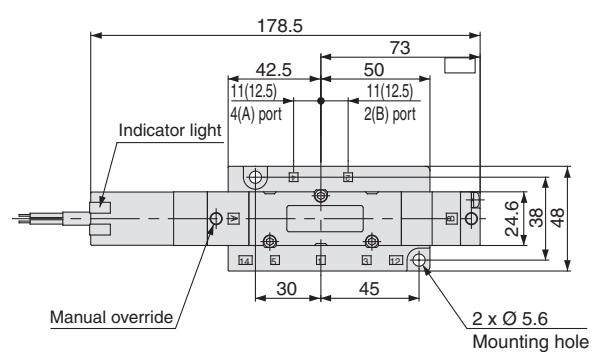
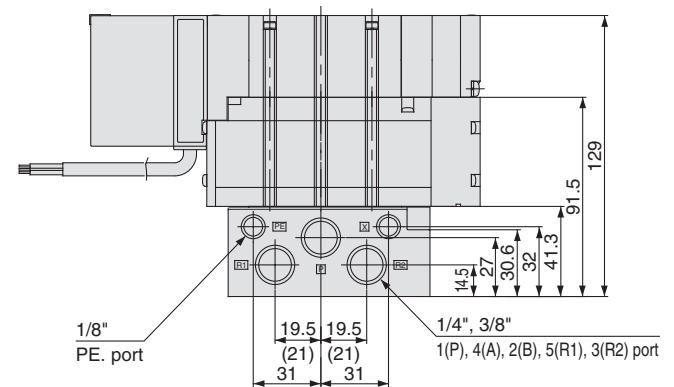

: Values for 3-position
 (): Values for 3/8"

Base Mounted

Plug-in Unit

Series VQ4000

How to Order Manifold

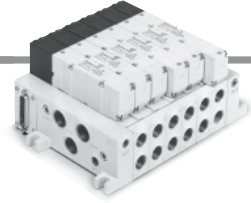

VV5Q 4 1 - 08 C8 [] FU1 [] - [] - Q

Series
4 VQ4000

Manifold
1 Plug-in unit

Stations
01 1 station
:
:
:
:

Thread type

—	Rc
F	G
N	NPT
T	NPTF

Control unit
Refer to pages 37 to 40.

Option

Symbol	Option
—	None
CD Note 2)	Exhaust cleaner: For D side mounting
CU Note 2)	Exhaust cleaner: For U side mounting
K Note 3)	Special wiring specifications (Except double wiring)
N	Name plate (T kit only)
SB	Direct exhaust with silencer box: Exhaust from both sides (F/L kits only)
SD Note 2)	Direct exhaust with silencer box: D side exhaust
SU Note 2)	Direct exhaust with silencer box: U side exhaust
W	Enclosure IP65 (Except F kit)

The maximum and minimum number of stations are varied depending on kit.
(Refer to the table below.)

Cylinder port

C6	Ø 6 One-touch fitting
C8	Ø 8 One-touch fitting
C10	Ø 10 One-touch fitting
C12	Ø 12 One-touch fitting
02	1/4
03	3/8
B	Bottom ported 1/4
CM	Mixed
N7	Ø 1/4" One-touch fitting
N9	Ø 5/16" One-touch fitting
N11	Ø 3/8" One-touch fitting

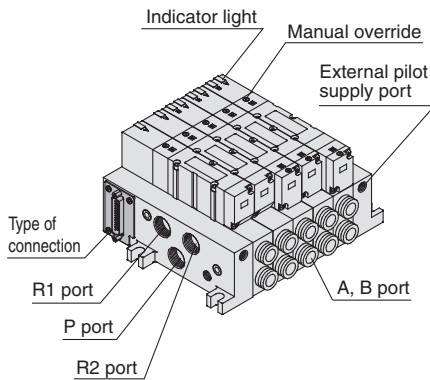

Note) Figure shows VV5Q41-05C12FD0.

S, T kit

When mounting a terminal block box or serial unit, be aware that they take up 2 stations of the manifold. In the drawing below, you can see that of the 8 manifold stations, 6 stations are available to be used for built-in valves, options, etc.

VV5Q41-08C10T0

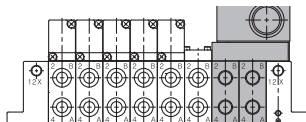

Kit type/Electrical entry/Cable length

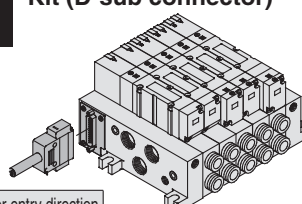
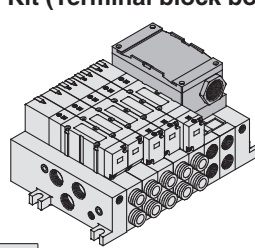
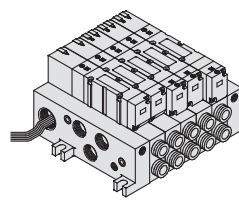
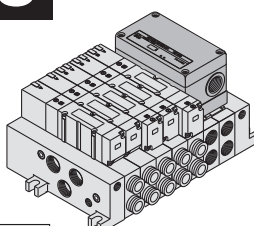
<p>F Kit (D-sub connector)</p> 	<p>Connector entry direction</p> <table border="1"> <thead> <tr> <th>D side</th> <th>U side</th> </tr> </thead> <tbody> <tr> <td>Kit D0</td> <td>Kit U0</td> </tr> <tr> <td>Kit D1</td> <td>Kit U1</td> </tr> <tr> <td>Kit D2</td> <td>Kit U2</td> </tr> <tr> <td>Kit D3</td> <td>Kit U3</td> </tr> </tbody> </table>		D side	U side	Kit D0	Kit U0	Kit D1	Kit U1	Kit D2	Kit U2	Kit D3	Kit U3	<p>Without cable</p> <p>Cable length 1.5 m</p> <p>Cable length 3 m</p> <p>Cable length 5 m</p>	<p>1 to 18 stations</p>	<p>T Kit (Terminal block box kit)</p> 	<p>Terminal block mounting position</p> <table border="1"> <thead> <tr> <th>D side</th> <th>U side</th> </tr> </thead> <tbody> <tr> <td>TD</td> <td>T0</td> </tr> </tbody> </table>	D side	U side	TD	T0	<p>IP65 compatible</p> <p>3 to 18 stations (Note 1)</p>
	D side	U side																			
	Kit D0	Kit U0																			
	Kit D1	Kit U1																			
Kit D2	Kit U2																				
Kit D3	Kit U3																				
D side	U side																				
TD	T0																				
<p>L Kit (Lead wire cable)</p> 	<p>Electrical entry</p> <table border="1"> <thead> <tr> <th>D side</th> <th>U side</th> </tr> </thead> <tbody> <tr> <td>Kit D0</td> <td>Kit U0</td> </tr> <tr> <td>Kit D1</td> <td>Kit U1</td> </tr> <tr> <td>Kit D2</td> <td>Kit U2</td> </tr> </tbody> </table>		D side	U side	Kit D0	Kit U0	Kit D1	Kit U1	Kit D2	Kit U2	<p>Cable length 0.6 m</p> <p>Cable length 1.5 m</p> <p>Cable length 3 m</p>	<p>1 to 16 stations</p>	<p>S Kit (Serial transmission unit)</p> 	<p>The valve is equipped with a lamp/surge suppressor, and the voltage is 24 VDC.</p>	<p>IP65 compatible</p> <p>* Applicable to INPUT and OUTPUT type.</p>						
	D side	U side																			
	Kit D0	Kit U0																			
Kit D1	Kit U1																				
Kit D2	Kit U2																				
<p>Unit mounting position</p> <table border="1"> <thead> <tr> <th>D side</th> <th>U side</th> </tr> </thead> <tbody> <tr> <td>SD</td> <td>S</td> </tr> </tbody> </table>		D side	U side	SD	S	<p>Without SI Unit</p> <p>DeviceNet</p> <p>OMRON Corp.: CompoBus/S System (16 output points)</p> <p>OMRON Corp.: CompoBus/S System (8 output points)</p> <p>CC-Link</p>	<p>Note 1)</p> <p>3 to 18 stations</p>														
D side	U side																				
SD	S																				

Note 1) For the T kit and S kit, 2 stations are required to mount the terminal block box or SI Unit, so the minimum number of stations is 3 stations.

Simple specials are available with SMC Simple Special System.
Please contact the local SMC representative to find out more details.

Manifold Specifications

Series	Base model	Type of connection	Porting specifications		Maximum applicable stations	Applicable valve	Weight [kg] (Formula)	
			4(A), 2(B) port location	Port size				
				1(P), 5(R1), 3(R2)				4(A), 2(B)
VQ4000	VV5Q41-□□□	<ul style="list-style-type: none"> ■ F kit—D-sub connector ■ T kit—Terminal block box ■ L kit—Lead wire ■ S kit—Serial transmission 	Side	1/2 Option (Direct exhaust with silencer box)	C6 (For Ø 6) C8 (For Ø 8) C10 (For Ø 10) C12 (For Ø 12) 1/4 3/8 N7 (For Ø 1/4") N9 (For Ø 5/16") N11 (For Ø 3/8")	F, T kit 18 stations L kit 16 stations S kit 18 stations	VQ4□00 VQ4□01	F, L kit: $0.32n + 0.75$ S, T kit: $0.32(n-2) + 1.8$ • Not including valve weight.
			Bottom		1/4			

Flow-rate Characteristics at the Number of Manifold Stations (Operated individually)

n: Stations

Model	Passage/Stations		Station 1	Station 5	Station 10	Station 15
2-position metal seal VQ4 ₂ 00	1 → 4/2 (P → A/B)	C [dm ³ /(s·bar)]	5.9	5.9	5.9	5.9
		b	0.23	0.23	0.23	0.23
		Cv	1.5	1.5	1.5	1.5
		Q [l/min (ANR)] note 2)	1438	1438	1438	1438
	4/2 → 5/3 (A/B → EA/EB)	C [dm ³ /(s·bar)]	6.2	6.2	6.2	6.2
		b	0.19	0.19	0.19	0.19
Cv		1.5	1.5	1.5	1.5	
Q [l/min (ANR)] note 2)		1427	1427	1427	1427	
2-position rubber seal VQ4 ₂ 01	1 → 4/2 (P → A/B)	C [dm ³ /(s·bar)]	6.8	6.8	6.8	6.8
		b	0.31	0.31	0.31	0.31
		Cv	1.8	1.8	1.8	1.8
		Q [l/min (ANR)] note 2)	1740	1740	1740	1740
	4/2 → 5/3 (A/B → EA/EB)	C [dm ³ /(s·bar)]	7.0	7.0	7.0	7.0
		b	0.38	0.38	0.38	0.38
		Cv	1.9	1.9	1.9	1.9
		Q [l/min (ANR)] note 2)	1877	1877	1877	1877

Note 1) Port size: 3/8. Note 2) These values have been calculated according to ISO 6358 and indicate the flow rate under standard conditions with an inlet pressure of 0.6 MPa (relative pressure) and a pressure drop of 0.1 MPa.

Manifold Options

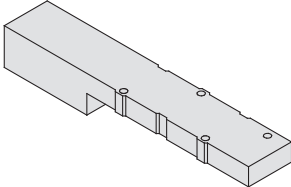
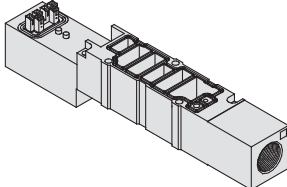
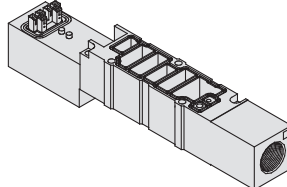
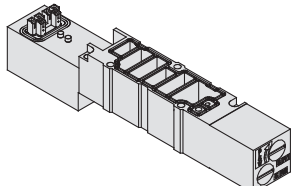
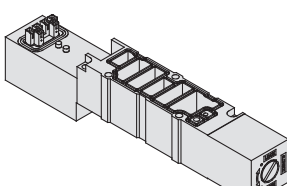
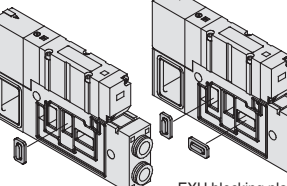
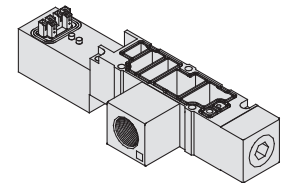
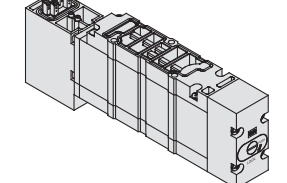
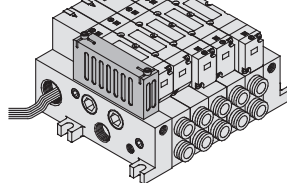
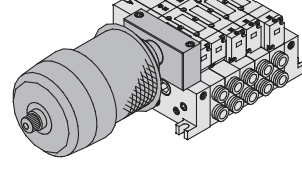
<p>Blanking plate assembly VVQ4000-10A-1</p> 	<p>Individual SUP spacer VVQ4000-P-1-⁰²/₀₃</p> 	<p>Individual EXH spacer VVQ4000-R-1-⁰²/₀₃</p> 	<ul style="list-style-type: none"> • Refer to pages 31 to 35 for detailed dimensions of each option. • For replacement parts, refer to page 44. • Refer to pages 37 to 40 for control unit.
<p>Restrictor spacer VVQ4000-20A-1</p> 	<p>SUP stop valve spacer VVQ4000-37A-1</p> 	<p>SUP/EXH block plate VVQ4000-16A</p>  <p>< SUP blocking plate > < EXH blocking plate ></p>	
<p>Release valve spacer: For D side mounting VVQ4000-24A-1D <small>Note 1) 2)</small></p> 	<p>Double check spacer with residual pressure exhaust VVQ4000-25A-1 <small>Note 1)</small></p> 	<p>Direct exhaust with silencer box [-S_D⁰]</p> 	<p>Manifold mounted exhaust cleaner [-C_D⁰]</p> 

Note 1) Release valve spacer and double check spacer with residual pressure exhaust cannot be combined with external pilot.

Note 2) Can be mounted on L kit only. For other kits, order E type control unit. (Refer to pages 37 to 40.)

Series VQ4000

F Kit (D-sub connector kit)

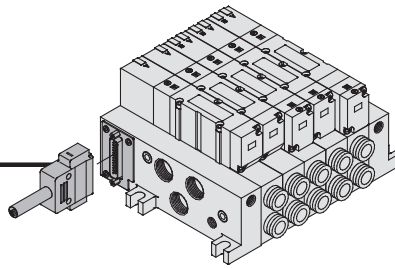

- Simplification and labour savings for wiring work can be achieved by using a D-sub connector for the electrical connection.
- Using connector for flat ribbon cable (25P) conforming to MIL standard permits the use of connectors put on the market and gives a wide interchangeability.
- Connector entry can be selected on either the U side or the D side according to the mounting orientation.
- Maximum stations are 18.

Manifold Specifications

Series	Porting specifications			Applicable stations
	4(A), 2(B) port location	Port size		
		1(P), 5(R1), 3(R2)	4(A), 2(B)	
VQ4000	Side	1/2	C6, C8, C10, C12, 1/4, 3/8, N7, N9, N11	Max. 18 stations
	Bottom		1/4	

D-Sub Connector Kit (25 pins)

Cable assembly ●

015
AXT100-DS25-030
050

(D-sub connector cable assemblies can be ordered by with manifolds.)
Refer to How to Order Manifold.

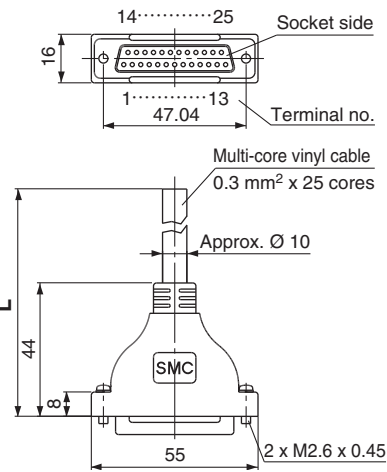

D-sub Connector Cable Assembly

Cable length (L)	Assembly part no.	Note
1.5 m	AXT100-DS25-015	Cable
3 m	AXT100-DS25-030	0.3 mm ²
5 m	AXT100-DS25-050	x 25 cores

- * For other commercial connectors, use a 25-pin type female connector conforming to MIL-C-24308.
- * Cannot be used for transfer wiring.

Connector Manufacturers Example

- Fujitsu, Ltd.
- Japan Aviation Electronics Industry, Ltd.
- J.S.T. Mfg. Co., Ltd.
- Hirose Electric Co., Ltd.

Electric Characteristics

Item	Characteristics
Conductor resistance Ω/km, 20 °C	65 or less
Voltage limit V AC, 1 min.	1000
Insulation resistance MΩ/km, 20 °C	5 or more

Note) The minimum bending radius for D-sub connector cables is 20 mm.

D-sub Connector Cable Assembly Terminal No.

Terminal no.	Lead wire colour	Dot marking
1	Black	None
2	Brown	None
3	Red	None
4	Orange	None
5	Yellow	None
6	Pink	None
7	Blue	None
8	Purple	White
9	Grey	Black
10	White	Black
11	White	Red
12	Yellow	Red
13	Orange	Red
14	Yellow	Black
15	Pink	Black
16	Blue	White
17	Purple	None
18	Grey	None
19	Orange	Black
20	Red	White
21	Brown	White
22	Pink	Red
23	Grey	Red
24	Black	White
25	White	None

Note) Lengths other than the above are also available. Please contact SMC for details.

How to Order Manifold



VV5Q 4 1 - 08 C8 [] F U 1 - [] - Q

Series

4	VQ4000
---	--------

Manifold

1	Plug-in unit
---	--------------

Stations

01	1 station
⋮	⋮
18	18 stations

Cylinder port

C6	Ø 6 One-touch fitting
C8	Ø 8 One-touch fitting
C10	Ø 10 One-touch fitting
C12	Ø 12 One-touch fitting
02	1/4
03	3/8
B	Bottom ported 1/4
CM	Mixed
N7	Ø 1/4" One-touch fitting
N9	Ø 5/16" One-touch fitting
N11	Ø 3/8" One-touch fitting

Thread type

—	Rc
F	G
N	NPT
T	NPTF

Connector entry direction

D	D side entry
U	U side entry

Cable (Length)

0	Without cable
1	Cable length 1.5 m
2	Cable length 3 m
3	Cable length 5 m

Option

Symbol	Option
—	None
CD ^{Note 2)}	Exhaust cleaner: For D side mounting
CU ^{Note 2)}	Exhaust cleaner: For U side mounting
K ^{Note 3)}	Special wiring specifications (Except double wiring)
SB ^{Note 2)}	Direct exhaust with silencer box: Exhaust from both sides
SD ^{Note 2)}	Direct exhaust with silencer box: D side exhaust
SU ^{Note 2)}	Direct exhaust with silencer box: U side exhaust

Note 1) When multiple symbols are specified, indicate them alphabetically.
Example) -CDK

Note 2) Combination of [C_D^U] and [S_D^U] is not possible.

Note 3) Specify the wiring specifications on the manifold specification sheet.

Note 4) Refer to pages 37 to 40 for with control unit.

Note) As a semi-standard specification, the maximum number of stations can be increased by special wiring specifications. For details, refer to page 12.

● **Electrical wiring specifications**

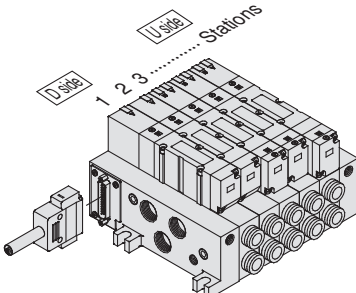

Stations are counted starting from the first station on the D side.

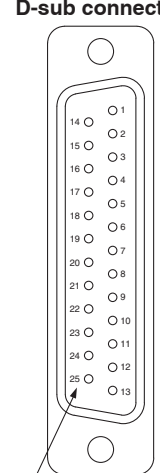

Connector terminal no.

Double wiring (connected to SOL. A and SOL. B) is adopted for the internal wiring of each station, regardless of valve and option types. Mixed single and double wiring is available as a semi-standard specification. For details, refer to below.

Note) There is no polarity. It can also be used as a negative common.

Station	Terminal no.	Wiring	Terminal no.	Polarity	Lead wire colour	Dot marking	
1 station	SOL.A	1	Release valve	1 (-)	(+)	Black	None
	SOL.B	14	Pressure switch	14 (+)	(-)	Yellow	Black
2 stations	SOL.A	2		2 (-)	(+)	Brown	None
	SOL.B	15		15 (+)	(-)	Pink	Black
3 stations	SOL.A	3		3 (-)	(+)	Red	None
	SOL.B	16		16 (-)	(+)	Blue	White
4 stations	SOL.A	4		4 (-)	(+)	Orange	None
	SOL.B	17		17 (-)	(+)	Purple	None
5 stations	SOL.A	5		5 (-)	(+)	Yellow	None
	SOL.B	18		18 (-)	(+)	Grey	None
6 stations	SOL.A	6		6 (-)	(+)	Pink	None
	SOL.B	19		19 (-)	(+)	Orange	Black
7 stations	SOL.A	7		7 (-)	(+)	Blue	None
	SOL.B	20		20 (-)	(+)	Red	White
8 stations	SOL.A	8		8 (-)	(+)	Purple	White
	SOL.B	21		21 (-)	(+)	Brown	White
9 stations	SOL.A	9		9 (-)	(+)	Grey	Black
	SOL.B	22		22 (-)	(+)	Pink	Red
10 stations	SOL.A	10		10 (-)	(+)	White	Black
	SOL.B	23		23 (-)	(+)	Grey	Red
11 stations	SOL.A	11		11 (-)	(+)	White	Red
	SOL.B	24		24 (-)	(+)	Black	White
12 stations	SOL.A	12		12 (-)	(+)	Yellow	Red
	SOL.B	25		25 (-)	(+)	White	None
	COM.	13		13 (+)	(-)	Orange	Red

Positive common specifications Negative common specifications

Special Wiring Specifications

Double wiring (connected to SOL. A and SOL. B) is used for the internal wiring of each station regardless of valve and option types. Mixed single and double wiring is available as a semi-standard specification.

1. How to Order

Indicate option symbol "K" in the manifold part number and be sure to specify station positions for single or double wiring on the manifold specification sheet.

2. Wiring specifications

Connections begin with the A side solenoid of the first station being connected to terminal no. 1, and continue in the order indicated by the arrows in the drawing without skipping any terminals. Maximum stations are 18.

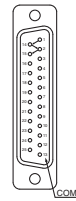

D-sub connector

How to Order Valves



VQ 4 1 0 0 - 5 1 - Q

Type of actuation	
1	2-position single
2	2-position double
3	3-position closed centre
4	3-position exhaust centre
5	3-position pressure centre
6	3-position double check

Manual override	
—	Non-locking push type (Tool required)
B	Locking type (Tool required)
C	Locking type (Manual)

Light/Surge voltage suppressor	
—	Yes
E	Without light, with surge voltage suppressor

Coil voltage	
5	24 V DC
6	12 V DC

Seal	
0	Metal seal
1	Rubber seal

Function	
— Note 1)	Standard (0.95 W)
Y	Low wattage type (0.4 W)
R Note 2)	External pilot

Series: 4 VQ4000

How to Order Manifold Assembly

Specify the part numbers for valves and options together beneath the manifold base part number.

<Example>

D-sub connector kit with cable (3 m)
VV5Q41-05C8FD2[-Q]...1 set—Manifold base part no.
 *VQ4100-51[-Q]...2 sets—Valve part no. (Stations 1 and 2)
 *VQ4200-51[-Q]...2 sets—Valve part no. (Stations 3 and 4)
 *VQ4300-51[-Q]...1 set—Valve part no. (Station 5)

Prefix the asterisk to the part nos. of the valve etc.

Enter in order starting from the first station on the D side. When entry of part numbers becomes complicated, indicate in the manifold specification sheet.

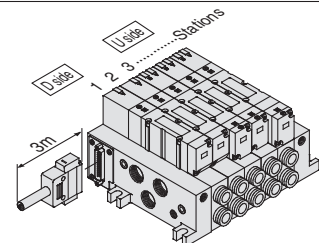

Note 1) When the unit is energised continuously, refer to "Specific Product Precautions 1" on page 88.
 Note 2) For external pilot specifications, refer to page 36. Combination of external pilot and perfect interface is not possible.
 Note 3) When multiple symbols are specified, indicate them alphabetically.

VQ4000
 Manifold Options
 Semi-standard Specifications
 Manifold with Control Unit
 Construction
 Exploded View of Manifold

VQ5000
 Manifold Options
 Semi-standard Specifications
 Construction
 Exploded View of Manifold

Series VQ4000

F Kit (D-sub connector kit)

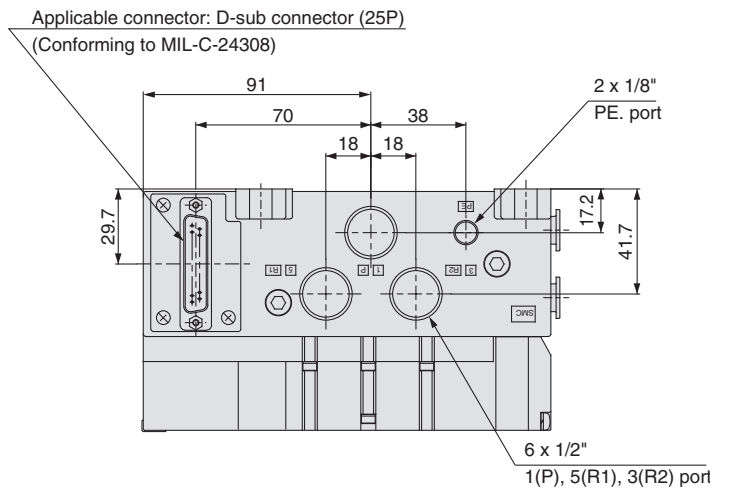
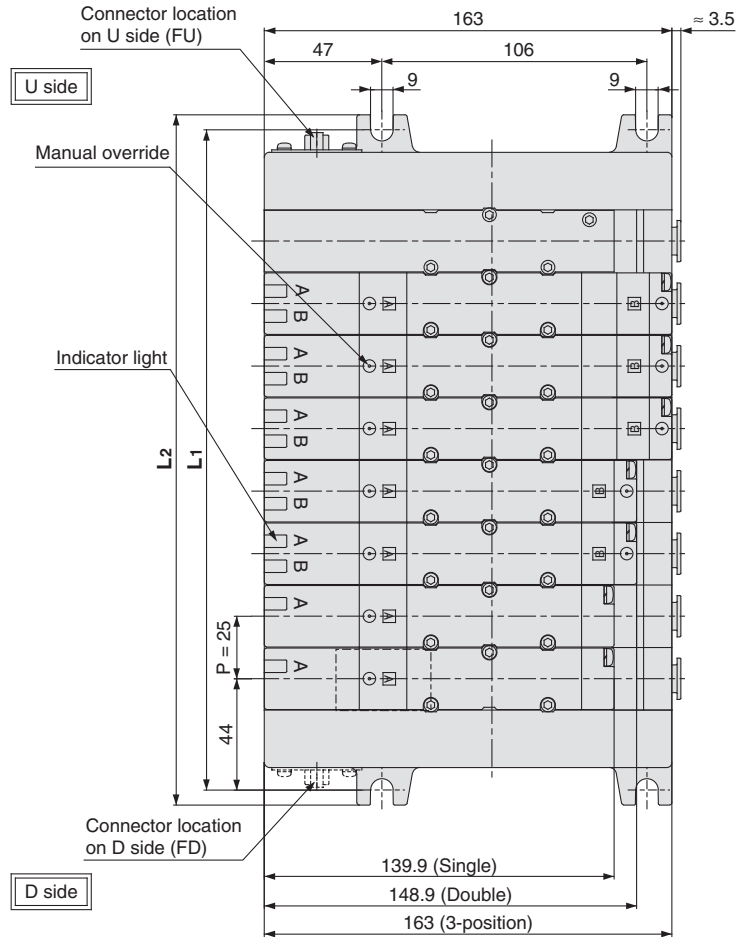
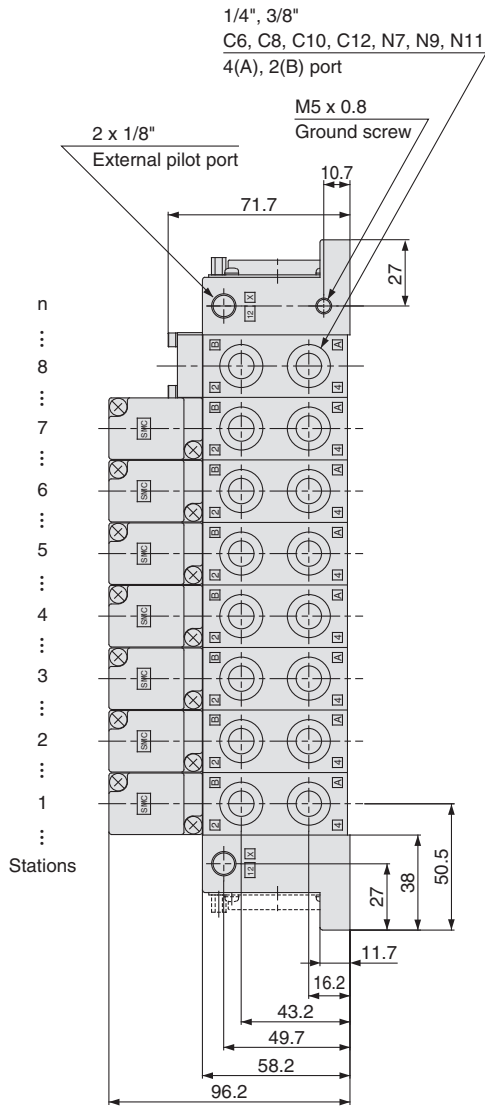

Series VQ4000

T Kit (Terminal block box kit)

IP65 compliant

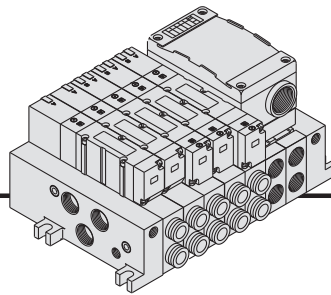

- Enclosure IP65 compliant
- This type has a small terminal block inside a junction box. The provision of a G 3/4 electrical entry allows connection of conduit fittings.
- Maximum stations are 18.
- 2 stations are used for terminal box mounting.

Manifold Specifications

Series	4(A), 2(B) port location	Porting specifications		Applicable stations
		Port size		
VQ4000	Side	1(P), 5(R1), 3(R2)	4(A), 2(B)	Max. 18 stations
		1/2	C6, C8, C10, C12, 1/4, 3/8, N7, N9, N11	
	Bottom		1/4	

Terminal Block Connections

Step 1. How to remove terminal block cover

Loosen the 4 mounting screws (M4) and open the terminal block cover.

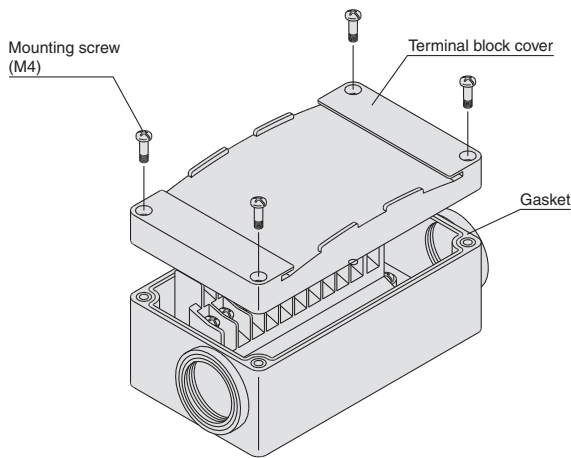

Step 2. The diagram on the right shows the terminal block wiring.

All stations are provided with double wiring regardless of the valves which are mounted.

Connect each wire to the power supply side, according to the markings provided inside the terminal block.

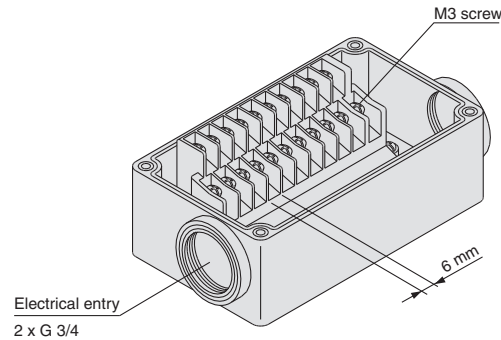

Step 3. How to attach the terminal block cover

Securely tighten the screws with the torque shown in the table below, after confirming that the gasket is installed correctly.

Proper tightening torque [N·m]
0.7 to 1.2

- Applicable terminal: 1.25-3S, 1.25Y-3, 1.25Y-3N, 1.25Y-3.5
- Name plate: VVQ5000-N-T
- Drip proof plug assembly (for G 3/4): AXT100-B06A

How to Order Manifold



VV5Q 4 1 - 08 C8 T 0 - Q

Series	Manifold	Stations
4 VQ4000	1 Plug-in unit	03 3 stations
		18 18 stations

Symbol	Option
—	None
CD ^{Note 2)}	Exhaust cleaner: D side exhaust
CU ^{Note 2)}	Exhaust cleaner: U side exhaust
K ^{Note 3)}	Special wiring specifications (Except double wiring, 13 stations or more)
N ^{Note 4)}	Name plate
SD ^{Note 2)}	Direct exhaust with silencer box: D side exhaust
SU ^{Note 2)}	Direct exhaust with silencer box: U side exhaust
W	IP65 enclosure

Note) 2 stations are used for mounting the terminal block box. The number of stations is the number of manifold valves plus 2 stations for the terminal block box. For 13 stations or more, specify the wiring specifications by means of the manifold specification sheet.

Note) As a semi-standard specification, the maximum number of stations can be increased by special wiring specifications. For details, refer to page 16.

Thread type

—	Rc
F	G
N	NPT
T	NPTF

Symbol	Option
—	None
0	U side mounting
D	D side mounting

Option

Symbol	Option
—	None
CD ^{Note 2)}	Exhaust cleaner: D side exhaust
CU ^{Note 2)}	Exhaust cleaner: U side exhaust
K ^{Note 3)}	Special wiring specifications (Except double wiring, 13 stations or more)
N ^{Note 4)}	Name plate
SD ^{Note 2)}	Direct exhaust with silencer box: D side exhaust
SU ^{Note 2)}	Direct exhaust with silencer box: U side exhaust
W	IP65 enclosure

Note 1) When multiple symbols are specified, indicate them alphabetically.
Example) -CDK

Note 2) Combination of [C_D^U] and [S_D^U] is not possible.

Note 3) Specify the wiring specifications on the manifold specification sheet.

Note 4) Name plate is inlaid in the terminal block cover.

Note 5) Refer to pages 37 to 40 for with control unit.

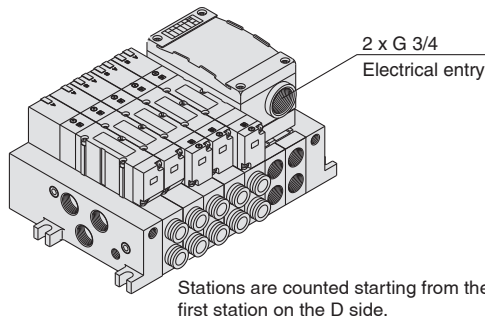

Electrical wiring specifications

	Standard wiring	Wiring with control unit	Polarity
1 station	SOL.A ○1A	Release valve ○1A	(-) (+)
	SOL.B ○1B	Pressure switch ○2A	(+) (-)
2 stations	SOL.A ○2A	SOL.A ○2B	(-) (+)
	SOL.B ○2B	SOL.B ○3A	(+) (-)
3 stations	SOL.A ○3A	SOL.A ○3B	(-) (+)
	SOL.B ○3B	SOL.A ○4A	(+) (-)
4 stations	SOL.A ○4A	SOL.B ○4B	(-) (+)
	SOL.B ○4B	SOL.A ○5A	(+) (-)
5 stations	SOL.A ○5A	SOL.B ○5B	(-) (+)
	SOL.B ○5B	SOL.A ○6A	(+) (-)
6 stations	SOL.A ○6A	SOL.B ○6B	(-) (+)
	SOL.B ○6B	SOL.A ○7A	(+) (-)
7 stations	SOL.A ○7A	SOL.B ○7B	(-) (+)
	SOL.B ○7B	SOL.A ○8A	(+) (-)
8 stations	SOL.A ○8A	SOL.B ○8B	(-) (+)
	SOL.B ○8B	SOL.A ○9A	(+) (-)
9 stations	SOL.A ○9A	SOL.B ○9B	(-) (+)
	SOL.B ○9B	SOL.A ○10A	(+) (-)
10 stations	SOL.A ○10A	SOL.B ○10B	(-) (+)
	SOL.B ○10B	○COM	(+) (-)
	○COM		Positive common Negative common

Double wiring (connected to SOL. A and SOL. B) is adopted for the internal wiring of each station, regardless of valve and option types. Mixed single and double wiring is available as a semi-standard specification.

Note) There is no polarity. It can also be used as a negative common.

Special Wiring Specifications

Double wiring (connected to SOL. A and SOL. B) is used for the internal wiring of each station regardless of valve and option types. Mixed single and double wiring is available as a semi-standard specification. However, the maximum number of stations is 16.

1. How to Order

Indicate option symbol "K" in the manifold part number and be sure to specify station positions for single or double wiring on the manifold specification sheet.

2. Wiring specifications

Connections begin with the A side solenoid of the first station being connected to terminal no. 1, and continue in the order indicated by the arrows in the drawing without skipping any terminals.



How to Order Valves



VQ 4 1 0 0 - 5 1 - Q

Type of actuation	
1	2-position single
2	2-position double
3	3-position closed centre
4	3-position exhaust centre
5	3-position pressure centre
6	3-position double check

Series

4	VQ4000
---	--------

Seal

0	Metal seal
1	Rubber seal

Function

—	Note 1) Standard (0.95 W)
Y	Low wattage type (0.4 W)
R	Note 2) External pilot

Enclosure

—	Dust-protected
W	Dust-tight/ Water-jet-proof (IP65)

Manual override

—	Non-locking push type (Tool required)
B	Locking type (Tool required)
C	Locking type (Manual)

Light/Surge voltage suppressor

—	Yes
E	Without light, with surge voltage suppressor

Coil voltage

5	24 V DC
6	12 V DC

Note 1) When the unit is energised continuously, refer to "Specific Product Precautions 1" on page 88.
 Note 2) For external pilot specifications, refer to page 36. Combination of external pilot and perfect interface is not possible.
 Note 3) When multiple symbols are specified, indicate them alphabetically.

How to Order Manifold Assembly

Specify the part numbers for valves and options together beneath the manifold base part number.

<Example>

Terminal block box kit
VV5Q41-07C8T0[-Q]...1 set—Manifold base part no.
 *VQ4100-51[-Q].....2 sets—Valve part no. (Stations 1 and 2)
 *VQ4200-51[-Q].....2 sets—Valve part no. (Stations 3 and 4)
 *VQ4300-51[-Q].....1 set—Valve part no. (Station 5)

Prefix the asterisk to the part nos. of the valve etc.

Enter in order starting from the first station on the D side. When entry of part numbers becomes complicated, indicate in the manifold specification sheet.

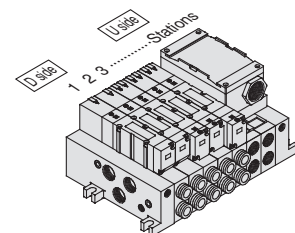

Series VQ4000

T Kit (Terminal block box kit)

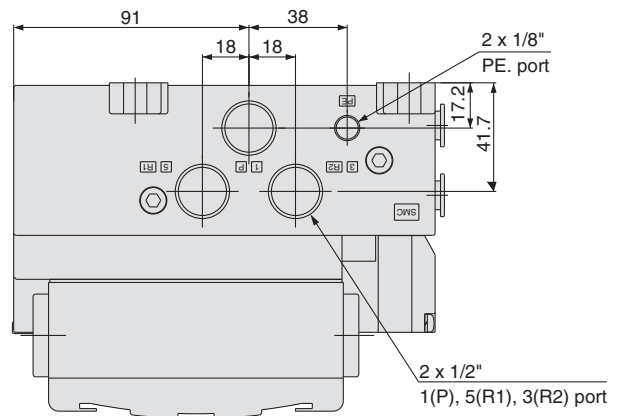
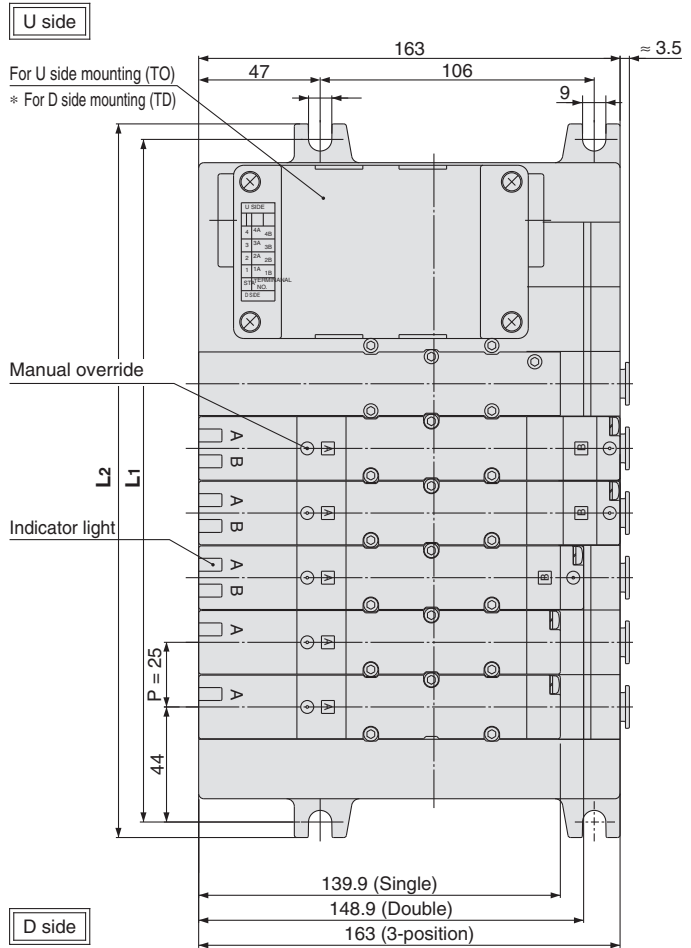
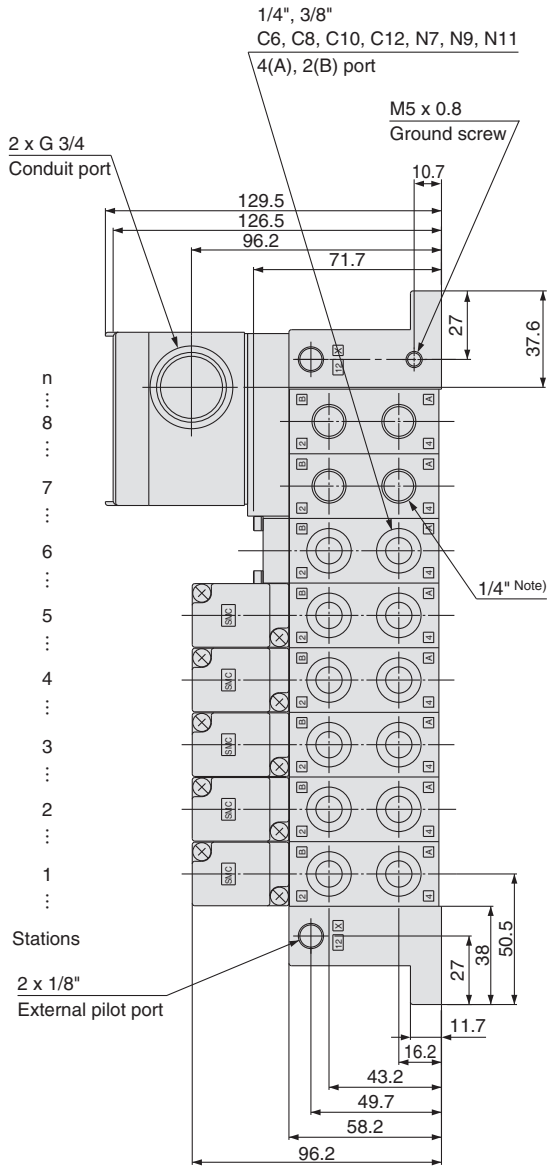

Shown VV5Q41-08C12TO-W.
Note) 4(A) and 2(B) port at the bottom of
the terminal block box are 1/4".

Bottom ported drawing

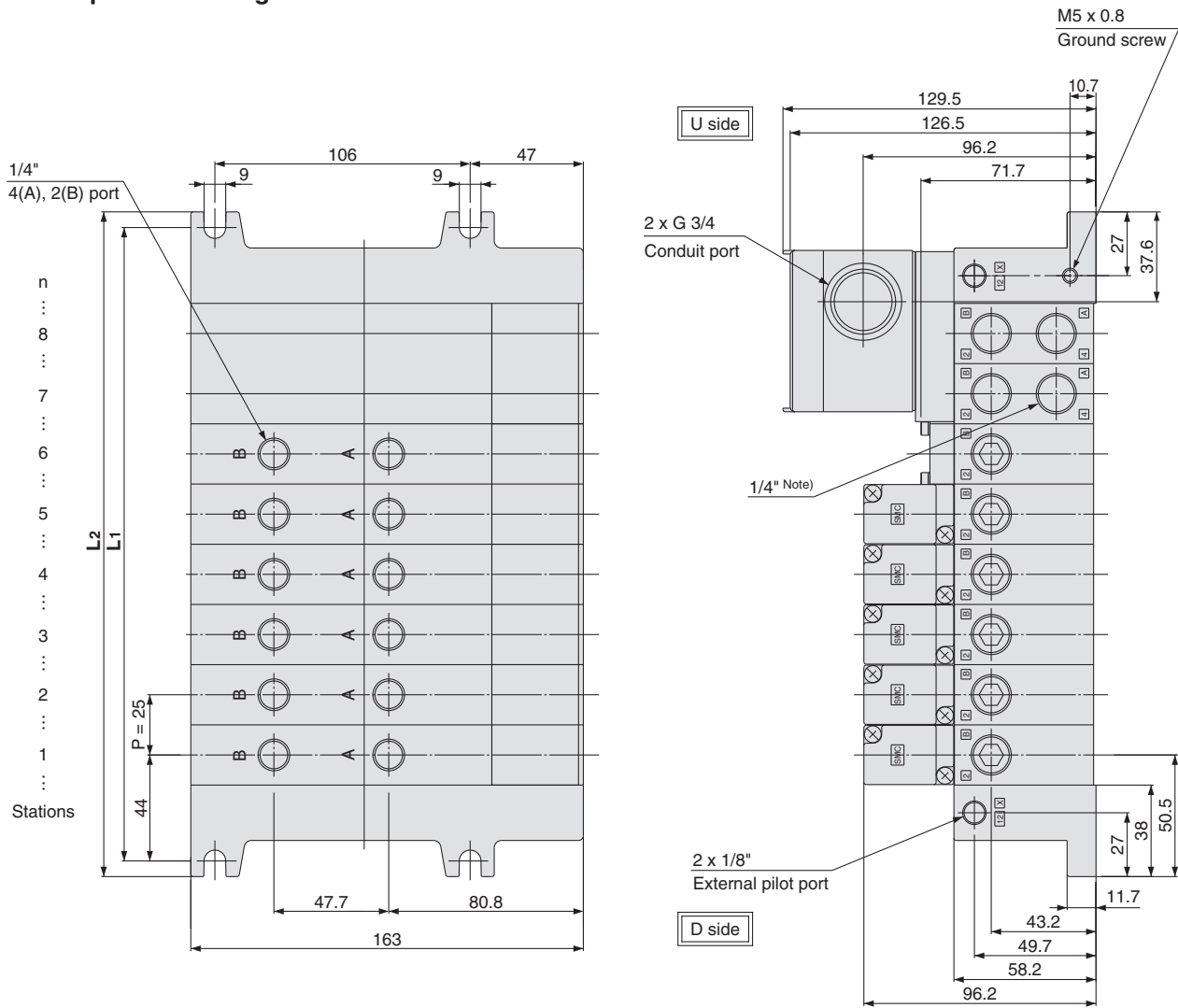

Note) 4(A) and 2(B) port at the bottom of the terminal block box are 1/4".

Dimensions

L \ n	3	4	5	6	7	8	9	10	11	12	13	14	15	16	17	18
L1	138	163	188	213	238	263	288	313	338	363	388	413	438	463	488	513
L2	151	176	201	226	251	276	301	326	351	376	401	426	451	476	501	526

Formula: $L_1 = 25n + 63$, $L_2 = 25n + 76$ n: Stations (Maximum standard 18 stations)
 * Including 2 stations for mounting terminal box.

VQ4000

Manifold Options

Semi-standard Specifications

Manifold with Control Unit

Construction

Exploded View of Manifold

VQ5000

Manifold Options

Semi-standard Specifications

Construction

Exploded View of Manifold

Series VQ4000

L Kit (Lead wire cable)

IP65 compliant

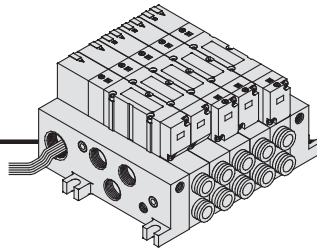

- Enclosure IP65 compliant
- Direct electrical entry. Models with two or more stations are available.
- Electrical entry can be selected on either the U side or the D side according to the mounting orientation.
- Maximum stations are 16.

Manifold Specifications

Series	4(A), 2(B) port location	Porting specifications		Applicable stations	
		1(P), 5(R1), 3(R2)	Port size		
			4(A), 2(B)		
VQ4000	Side	1/2	C6 (for Ø 6), C8 (for Ø 8), C10 (for Ø 10), C12 (for Ø 12), 1/4, 3/8, N7 (for Ø 1/4"), N9 (for Ø 5/16"), N11 (for Ø 3/8")		
	Bottom		1/4		

Wiring Specifications

Three lead wires are attached to each station regardless of the type of valve which is mounted. The red wire is for COM connection.

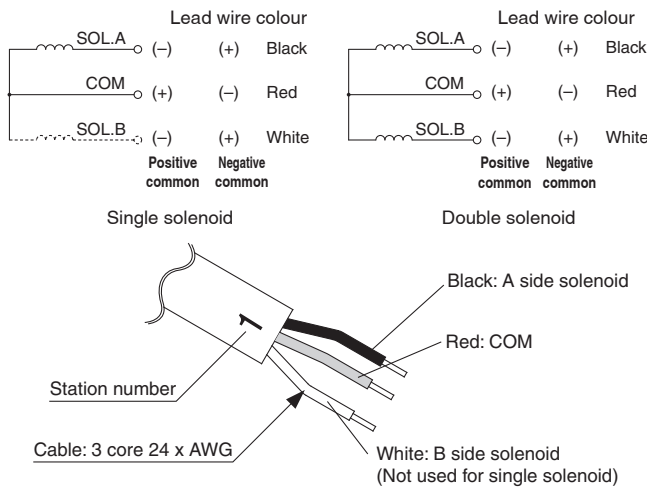

Lead Wire Assembly with Connector

Lead wire length	Part no.
0.6 m	VVQ5000-44A-8-□
1.5 m	VVQ5000-44A-15-□
3 m	VVQ5000-44A-30-□

□: Number of stations 1 to 16.

For different lead wire lengths, order a lead wire assembly with connector shown in the table on the right.

Note 1) There is no polarity. It can also be used as a negative common.

Note 2) Connect the release valve and the pressure switch to SOL. A side on the manifold with control unit.

How to Order Manifold



VV5Q 4 1 - 08 C8 [] L U [] - [] - Q

Series
4 VQ4000

Manifold
1 Plug-in unit

Stations

01	1 station
...	...
16	16 stations

Cylinder port

C6	Ø 6 One-touch fitting
C8	Ø 8 One-touch fitting
C10	Ø 10 One-touch fitting
C12	Ø 12 One-touch fitting
02	1/4
03	3/8
B	Bottom ported 1/4
CM	Mixed
N7	Ø 1/4" One-touch fitting
N9	Ø 5/16" One-touch fitting
N11	Ø 3/8" One-touch fitting

Connector locations

D	D side entry
U	U side entry

Cable (Length)

0	Cable length 0.6 m
1	Cable length 1.5 m
2	Cable length 3 m

Thread type

-	Rc
F	G
N	NPT
T	NPTF

Option

Symbol	Option
-	None
CD	Exhaust cleaner: For D side mounting
CU	Exhaust cleaner: For U side mounting
SB	Direct exhaust with silencer box: Exhaust from both sides
SD	Direct exhaust with silencer box: D side exhaust
SU	Direct exhaust with silencer box: U side exhaust
W	IP65 enclosure

Note 1) When multiple symbols are specified, indicate them alphabetically.

Example) -CDW

Note 2) Combination of [C_D] and [S_D] is not possible.

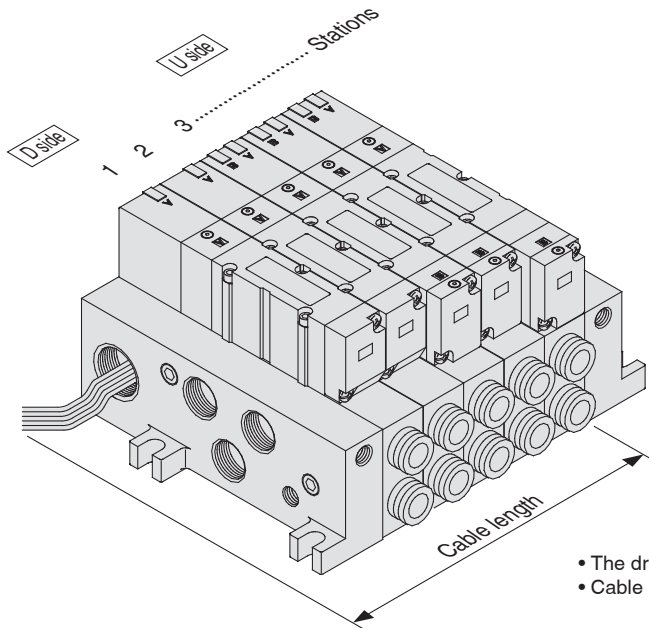

- The drawing shows the electrical entry on the D side.
- Cable length is measured from the valve body.

How to Order Valves



VQ 4 1 0 0 [] - 5 [] [] [] 1 - Q

Series

4	VQ4000
---	--------

Type of actuation

1	2-position single
2	2-position double
3	3-position closed centre
4	3-position exhaust centre
5	3-position pressure centre
6	3-position double check

Seal

0	Metal seal
1	Rubber seal

Function

— Note 1)	Standard (0.95 W)
Y	Low wattage type (0.4 W)
R Note 2)	External pilot

Enclosure

—	Dust-protected
W	Dust-tight/ Water-jet-proof (IP65)

Manual override

—	Non-locking push type (Tool required)
B	Locking type (Tool required)
C	Locking type (Manual)

Light/Surge voltage suppressor

—	Yes
E	Without light, with surge voltage suppressor

Coil voltage

5	24 V DC
6	12 V DC

Note 1) When the unit is energised continuously, refer to "Specific Product Precautions 1" on page 88.

Note 2) For external pilot specifications, refer to page 36. Combination of external pilot and perfect interface is not possible.

Note 3) When multiple symbols are specified, indicate them alphabetically.

How to Order Manifold Assembly

Specify the part numbers for valves and options together beneath the manifold base part number.

<Example>

Lead wire kit with cable (3 m)

VV5Q41-05C8LD2[-Q]...1 set—Manifold base part no.

*VQ4100-51[-Q].....2 sets—Valve part no. (Stations 1 and 2)

*VQ4200-51[-Q].....2 sets—Valve part no. (Stations 3 and 4)

*VQ4300-51[-Q].....1 set—Valve part no. (Station 5)

Prefix the asterisk to the part nos. of the valve etc.

Enter in order starting from the first station on the D side. When entry of part numbers becomes complicated, indicate in the manifold specification sheet.

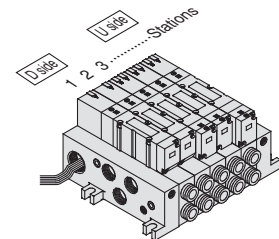

Series VQ4000

L Kit (Lead wire cable)

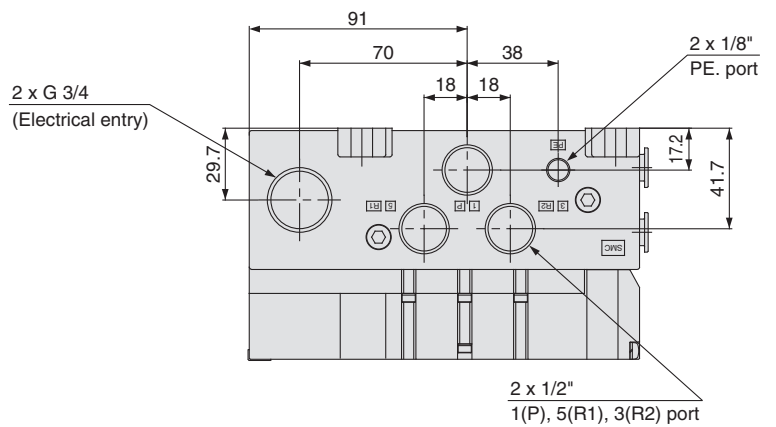
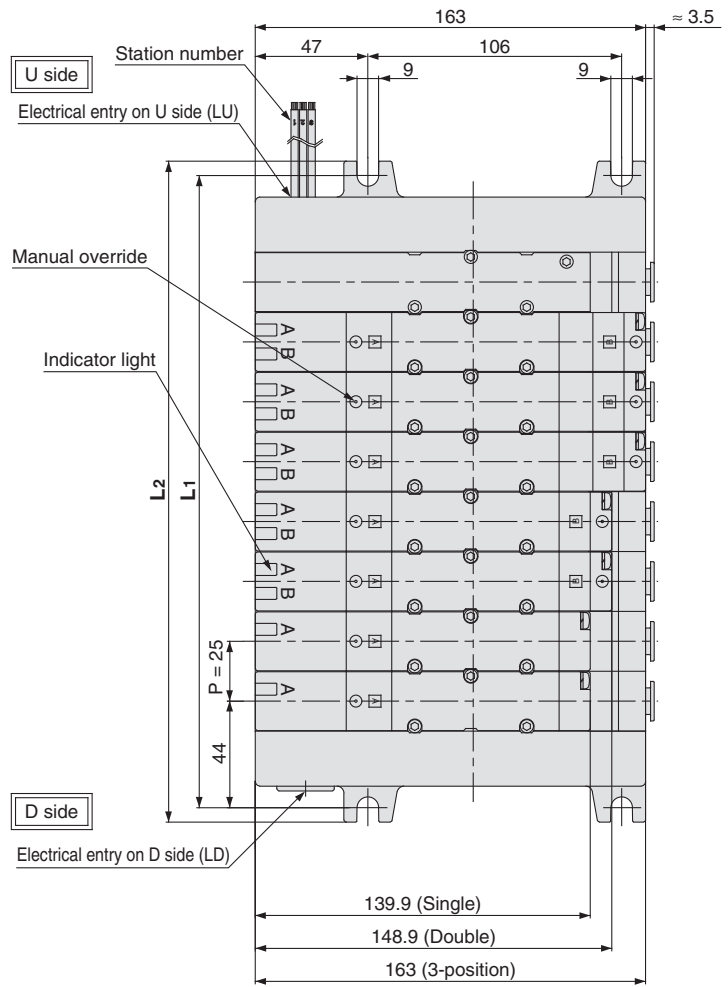
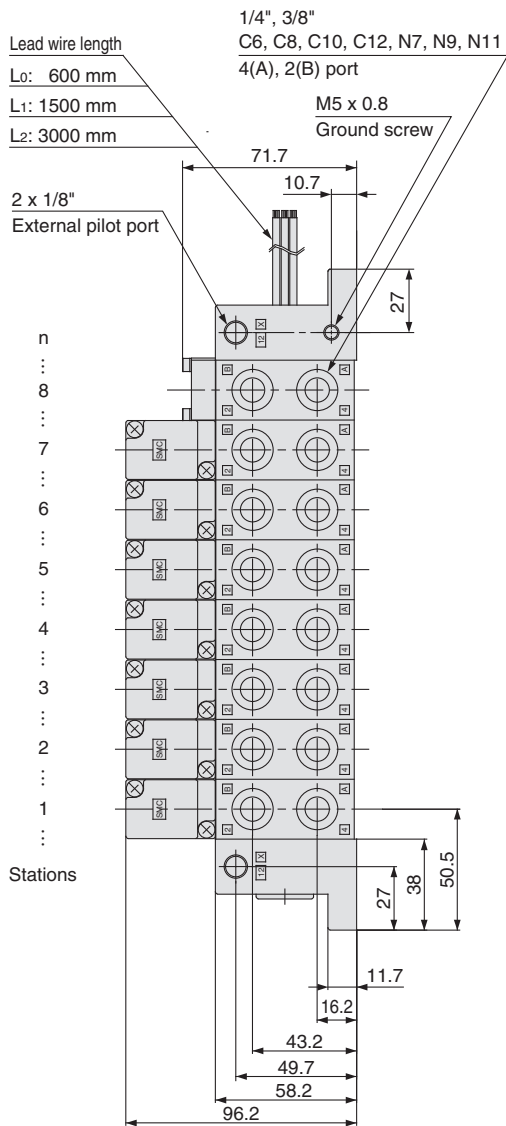

Series VQ4000

S

Kit (Serial transmission unit): EX123/124 (For Output) Serial Transmission System **IP65 compliant**

• The serial transmission system reduces wiring work, while minimising wiring and saving space.

• Double wiring (connected to SOL. A and SOL. B) is adopted for the internal wiring of each station, regardless of valve and option types. Mixed single and double wiring is available as a semi-standard specification.

Manifold Specifications

Series	Porting specifications			Applicable stations
	4(A), 2(B) port location	1(P), 5(R1), 3(R2)	Port size 4(A), 2(B)	
VQ4000	Side	1/2	C6 (for O 6), C8 (for O 8), C10 (for O 10), C12 (for O 12), 1/4, 3/8, N7 (for O 1/4"), N9 (for O 5/16"), N11 (for O 3/8")	Max. 18 stations
	Bottom		1/4	

Item	Specifications
External power supply	24 V DC +10 %, -5 %
Current consumption (Internal unit)	0.1 A

• Drip proof plug assembly (for G 1/2): AXT100-B04A



How to Order Manifold

VV5Q 4 1 - 08 C8 S V - Q

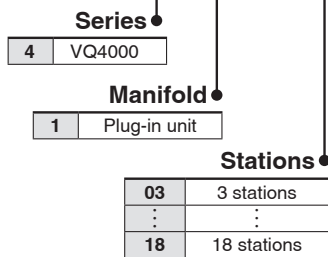

Note) 2 stations are used for mounting SI Unit. The number of stations is the number of manifold valves plus 2 stations for SI Unit. For 11 stations or more, specify the wiring specifications by means of the manifold specification sheet.

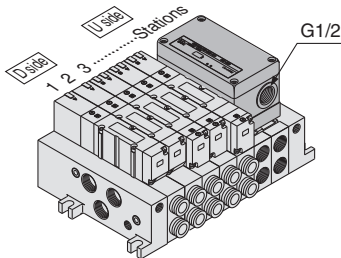

Stations are counted starting from the first station on the D side.

Cylinder port

C6	Ø 6 One-touch fitting
C8	Ø 8 One-touch fitting
C10	Ø 10 One-touch fitting
C12	Ø 12 One-touch fitting
02	1/4
03	3/8
B	Bottom ported 1/4
CM	Mixed
N7	Ø 1/4" One-touch fitting
N9	Ø 5/16" One-touch fitting
N11	Ø 3/8" One-touch fitting

Thread type

—	Rc
F	G
N	NPT
T	NPTF

Option

Symbol	Option
—	None
CD ^{Note 2)}	Exhaust cleaner: D side exhaust
CU ^{Note 2)}	Exhaust cleaner 1: U side exhaust
K ^{Note 3)}	Special wiring specifications (Except double wiring, 11 stations or more)
SD ^{Note 2)}	Direct exhaust with silencer box: D side exhaust
SU ^{Note 2)}	Direct exhaust with silencer box: U side exhaust
W ^{Note 2)}	IP65 enclosure

Note 1) When multiple symbols are specified, indicate them alphabetically. Example) -CDK

Note 2) Combination of [CD] and [SD] is not possible.

Note 3) Specify the wiring specifications in the manifold specification sheet.

Note 4) Refer to pages 37 to 40 for with control unit.

Note 5) The release valve and the pressure switch on the manifold with control unit are connected to another power supply.

SI Unit

0	Without SI Unit
Q	DeviceNet® (16 output points)
R1	OMRON Corp.: CompoBus/S System (16 output points)
R2	OMRON Corp.: CompoBus/S System (8 output points)
V	CC-Link (16 output points)

SI Unit Part No.

Symbol	Protocol type	SI Unit part no.	CE-compliant	Page
Q	DeviceNet® (16 output points)	D side: EX124D-SDN1		44
		U side: EX124U-SDN1		
R1	OMRON Corp.: CompoBus/S System (16 output points)	D side: EX124D-SCS1		44
		U side: EX124U-SCS1		
R2	OMRON Corp.: CompoBus/S System (8 output points)	D side: EX124D-SCS2		44
		U side: EX124U-SCS2		
V	CC-Link (16 output points)	D side: EX124D-SMJ1		44
		U side: EX124U-SMJ1		

Refer to the catalogue on SMC website, and the Operation Manual for the details of EX124 Integrated-type (For Output) Serial Transmission System. Please download the Operation Manual via SMC website, <http://www.smc.eu>

SI Unit mounting position

—	U side mounting
D	D side mounting



How to Order Valves

How to Order Manifold Assembly

VQ 4 1 0 0 [] - 5 [] [] [] 1 - Q

Specify the part numbers for valves and options together beneath the manifold base part number.

<Example>

- VV5Q41-07C8SV[-Q]...1 set—Manifold base part no.
- *VQ4100-51[-Q].....2 sets—Valve part no. (Stations 1 and 2)
- *VQ4200-51[-Q].....2 sets—Valve part no. (Stations 3 and 4)
- *VQ4300-51[-Q].....1 set—Valve part no. (Station 5)

Prefix the asterisk to the part nos. of the valve etc.

Enter in order starting from the first station on the D side. When entry of part numbers becomes complicated, indicate in the manifold specification sheet.

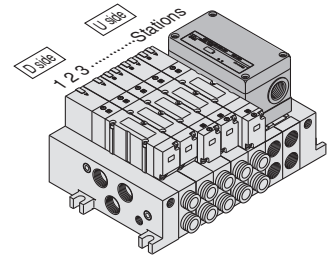

Series

4	VQ4000
---	--------

Type of actuation

1	2-position single
2	2-position double
3	3-position closed centre
4	3-position exhaust centre
5	3-position pressure centre
6	3-position double check

Seal

0	Metal seal
1	Rubber seal

Enclosure

—	Dust-protected
W	Dust-tight/ Water-jet-proof (IP65)

Manual override

—	Non-locking push type (Tool required)
B	Locking type (Tool required)
C	Locking type (Manual)

Light/Surge voltage suppressor

—	Yes
E	Without light, with surge voltage suppressor

Coil voltage

5	24 V DC
---	---------

Function

— Note 1)	Standard (0.95 W)
Y	Low wattage type (0.4 W)
R Note 2)	External pilot

Note 1) When the unit is energised continuously, refer to "Specific Product Precautions 1" on page 88.

Note 2) For external pilot specifications, refer to page 36. Combination of the external pilot and perfect interface is not possible.

Note 3) When multiple symbols are specified, indicate them alphabetically.

VQ4000

Manifold Options

Semi-standard Specifications

Manifold with Control Unit

Construction

Exploded View of Manifold

VQ5000

Manifold Options

Semi-standard Specifications

Construction

Exploded View of Manifold

Series VQ4000

S

Kit (Serial transmission unit): EX123/124 (For Output) Serial Transmission System

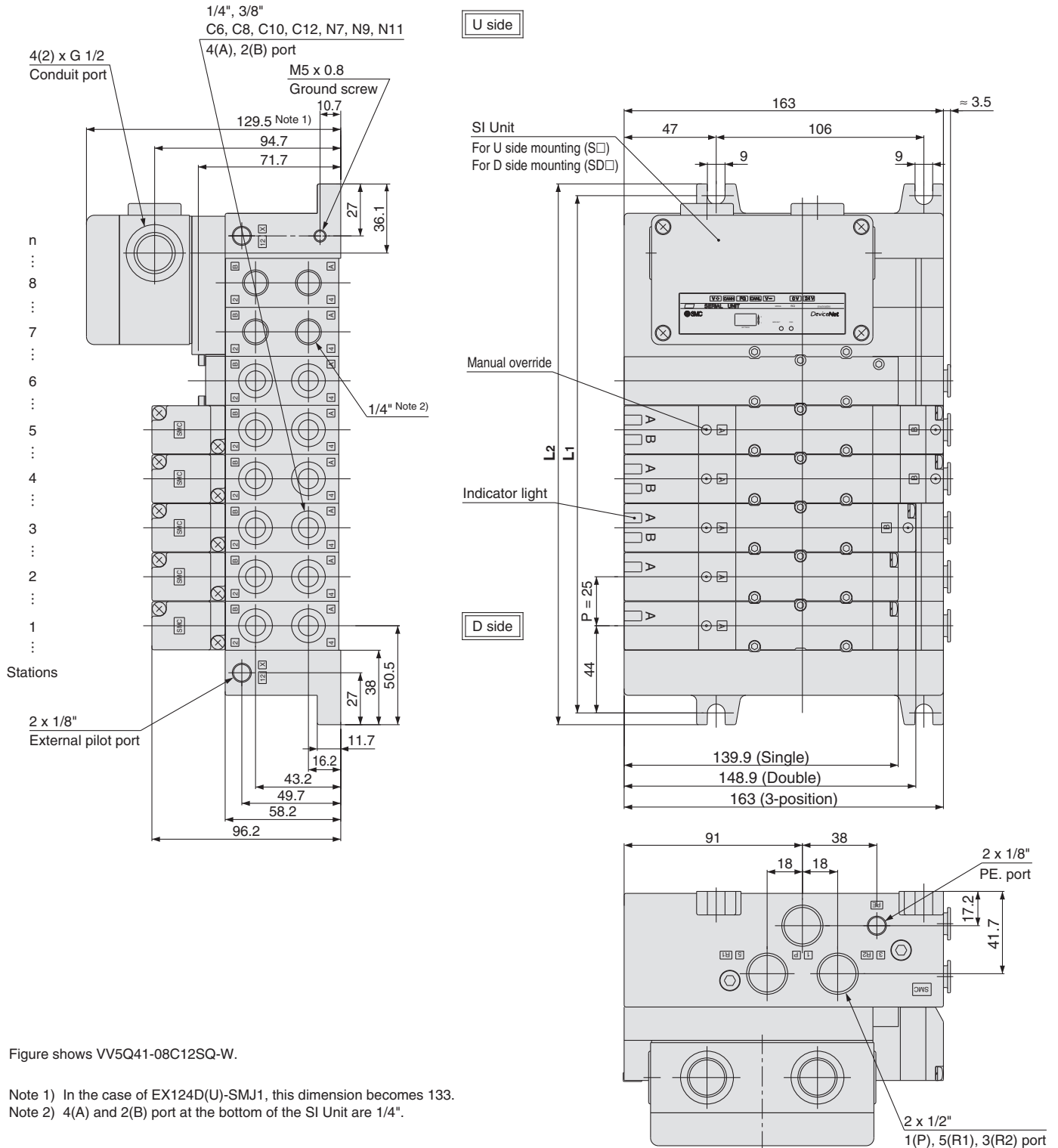

Figure shows VV5Q41-08C12SQ-W.

Note 1) In the case of EX124D(U)-SMJ1, this dimension becomes 133.

Note 2) 4(A) and 2(B) port at the bottom of the SI Unit are 1/4".

Dimensions

n	3	4	5	6	7	8	9	10	11	12	13	14	15	16	17	18
L1	138	163	188	213	238	263	288	313	338	363	388	413	438	463	488	513
L2	151	176	201	226	251	276	301	326	351	376	401	426	451	476	501	526

Formula: $L_1 = 25n + 63$, $L_2 = 25n + 76$ n: Stations (Maximum standard 18 stations)

* Including 2 stations for mounting SI Unit box.

Base Mounted

Plug Lead Unit: C Kit (Connector Kit)

Series VQ4000 C € UK CA

How to Order Manifold

VV5Q 4 5 - 08 C8 C - - - Q

Series

4	VQ4000
---	--------

Manifold

5	Plug lead unit
---	----------------

Stations

01	1 station
⋮	⋮
16	16 stations

Cylinder port

C6	Ø 6 One-touch fitting
C8	Ø 8 One-touch fitting
C10	Ø 10 One-touch fitting
C12	Ø 12 One-touch fitting
02	1/4
03	3/8
B	Bottom ported 1/4
CM	Mixed
N7	Ø 1/4" One-touch fitting
N9	Ø 5/16" One-touch fitting
N11	Ø 3/8" One-touch fitting

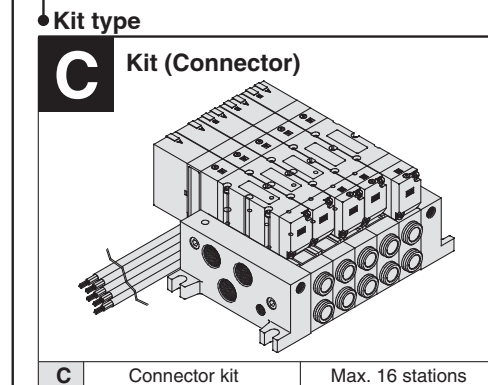

Thread type

-	Rc
F	G
N	NPT
T	NPTF

Option

Symbol	Option
-	None
CD ^{Note 2)}	Exhaust cleaner: For D side mounting
CU ^{Note 2)}	Exhaust cleaner: For U side mounting
SB ^{Note 2)}	Direct exhaust with silencer box: Exhaust from both sides
SD ^{Note 2)}	Direct exhaust with silencer box: D side exhaust
SU ^{Note 2)}	Direct exhaust with silencer box: U side exhaust
W	IP65 enclosure

Note 1) When multiple symbols are specified, indicate them alphabetically.
Example) -CDW

Note 2) Combination of [C_D^U] and [S_D^U] is not available. Also, exhaust cleaner is not attached. Please order it separately.

Refer to page 89 (Grommet type) for wiring specifications.

Control unit

Refer to pages 37 to 40.

How to Order Valves

VQ 4 1 5 0 - 5 G - - - 1 - Q

Type of actuation

1	2-position single
2	2-position double
3	3-position closed centre
4	3-position exhaust centre
5	3-position pressure centre
6	3-position double check

Seal

0	Metal seal
1	Rubber seal

Series

4	VQ4000
---	--------

Function

- ^{Note 1)}	Standard (0.95 W)
Y	Low wattage type (0.4 W)
R ^{Note 2)}	External pilot

Coil voltage

5	24 V DC
6	12 V DC

Note 1) When the unit is energised continuously, refer to "Specific Product Precautions 1" on page 88.

Note 2) For external pilot specifications, refer to page 36. Combination of the external pilot and perfect interface is not possible.

Note 3) When multiple symbols are specified, indicate them alphabetically.

Enclosure

-	Dust-protected
W	Dust-tight/ Water-jet-proof (IP65)

Manual override

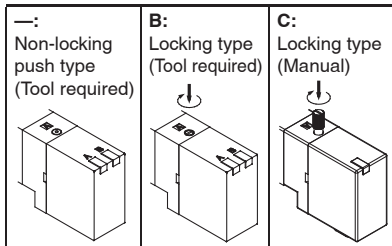

Light/Surge voltage suppressor

-	Yes
E	Without light, with surge voltage suppressor

Electrical entry

Grommet	G Lead wire length 0.6 m	
	H Lead wire length 1.5 m	

How to Order Manifold Assembly

Specify the part numbers for valves and options together beneath the manifold base part number.

<Example>

Connector kit

VV5Q45-05C12C[-Q]...1 set—Manifold base part no.

*VQ4150-5G1[-Q].....2 sets—Valve part no. (Stations 1 and 2)

*VQ4250-5G1[-Q].....2 sets—Valve part no. (Stations 3 and 4)

*VQ4350-5G1[-Q].....1 set—Valve part no. (Station 5)

Prefix the asterisk to the part nos. of the valve etc.

Enter in order starting from the first station on the D side. When entry of part numbers becomes complicated, indicate in the manifold specification sheet.

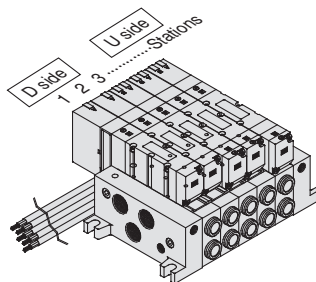

Manifold Specifications

Series	Base model	Type of connection	Porting specifications			Maximum applicable stations	Applicable valve	Weight [kg] (Formula)
			4(A), 2(B) port location	Port size				
				1(P), 5(R1), 3(R2)	4(A), 2(B)			
VQ4000	VV5Q45-□□□	■ C kit-Grommet	Side	1/2 Option (Direct exhaust with silencer box)	C6 C8 C10 C12 1/4 3/8 N7 N9 N11	2 to 16 stations	VQ4□50 VQ4□51	0.31n + 0.55 • Not including valve weight.
			Bottom		1/4			

n: Stations

Flow-rate Characteristics at the Number of Manifold Stations (Operated individually)

Model	Passage/Stations		Station 1	Station 5	Station 10	Station 15
2-position metal seal VQ4 ₁₅₀	1 → 4/2 (P → A/B)	C [dm ³ /(s-bar)]	5.9	5.9	5.9	5.9
		b	0.23	0.23	0.23	0.23
		Cv	1.5	1.5	1.5	1.5
	4/2 → 5/3 (A/B → EA/EB)	Q [l/min (ANR)] note 2)	1438	1438	1438	1438
		C [dm ³ /(s-bar)]	6.2	6.2	6.2	6.2
		b	0.19	0.19	0.19	0.19
2-position rubber seal VQ4 ₁₅₁	1 → 4/2 (P → A/B)	Cv	1.5	1.5	1.5	1.5
		Q [l/min (ANR)] note 2)	1427	1427	1427	1427
		C [dm ³ /(s-bar)]	6.8	6.8	6.8	6.8
	4/2 → 5/3 (A/B → EA/EB)	b	0.31	0.31	0.31	0.31
		Cv	1.8	1.8	1.8	1.8
		Q [l/min (ANR)] note 2)	1740	1740	1740	1740
	1 → 4/2 (P → A/B)	C [dm ³ /(s-bar)]	7.0	7.0	7.0	7.0
		b	0.38	0.38	0.38	0.38
		Cv	1.9	1.9	1.9	1.9
	4/2 → 5/3 (A/B → EA/EB)	Q [l/min (ANR)] note 2)	1877	1877	1877	1877

Note 1) Port size: 3/8. Note 2) These values have been calculated according to ISO 6358 and indicate the flow rate under standard conditions with an inlet pressure of 0.6 MPa (relative pressure) and a pressure drop of 0.1 MPa.

Manifold Options

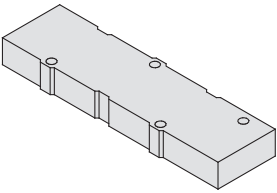
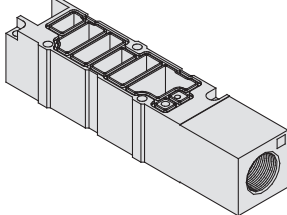
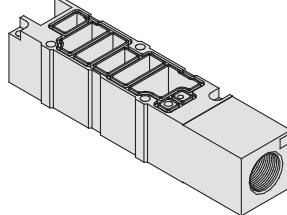
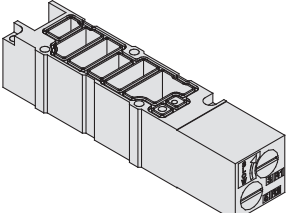
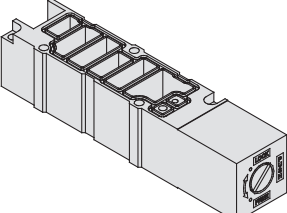
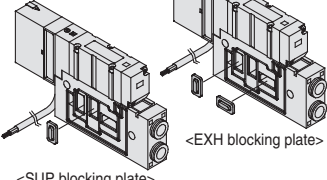
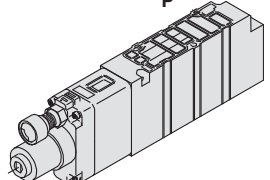
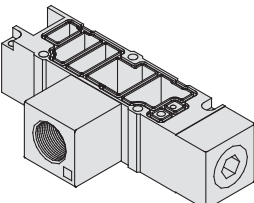
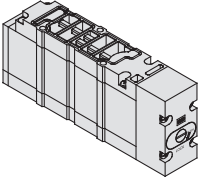
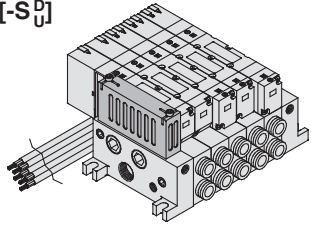
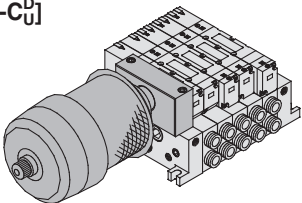
<p>Blanking plate assembly VVQ4000-10A-5</p> 	<p>Individual SUP spacer VVQ4000-P-5-⁰²/₀₃</p> 	<p>Individual EXH spacer VVQ4000-R-5-⁰²/₀₃</p> 	<p>• Refer to pages 31 to 35 for detailed dimensions of each option.</p> <p>• For replacement parts, refer to page 44.</p> <p>• Refer to pages 37 to 40 for control unit.</p>	
<p>Restrictor spacer VVQ4000-20A-5</p> 	<p>SUP stop valve spacer VVQ4000-37A-5</p> 	<p>SUP/EXH block plate VVQ4000-16A</p>  <p><SUP blocking plate> <EXH blocking plate></p>		<p>Interface regulator (P, A, B port regulation) ARBQ4000-00-^A/_B-5</p> 
<p>Release valve spacer: For D side mounting VVQ4000-24A-5D ^{Note)}</p> 	<p>Double check spacer with residual pressure exhaust VVQ4000-25A-5 ^{Note)}</p> 	<p>Direct exhaust with silencer box [-S_D]</p> 		<p>Manifold mounted exhaust cleaner [-C_D]</p> 

Note) Release valve spacer and double check spacer with residual pressure exhaust cannot be combined with external pilot.

Series VQ4000

C Kit (Connector kit)

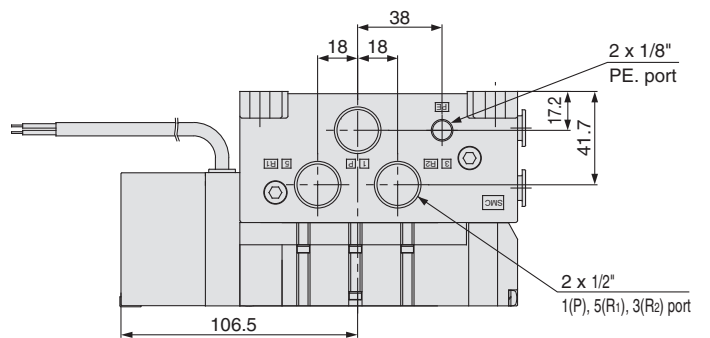
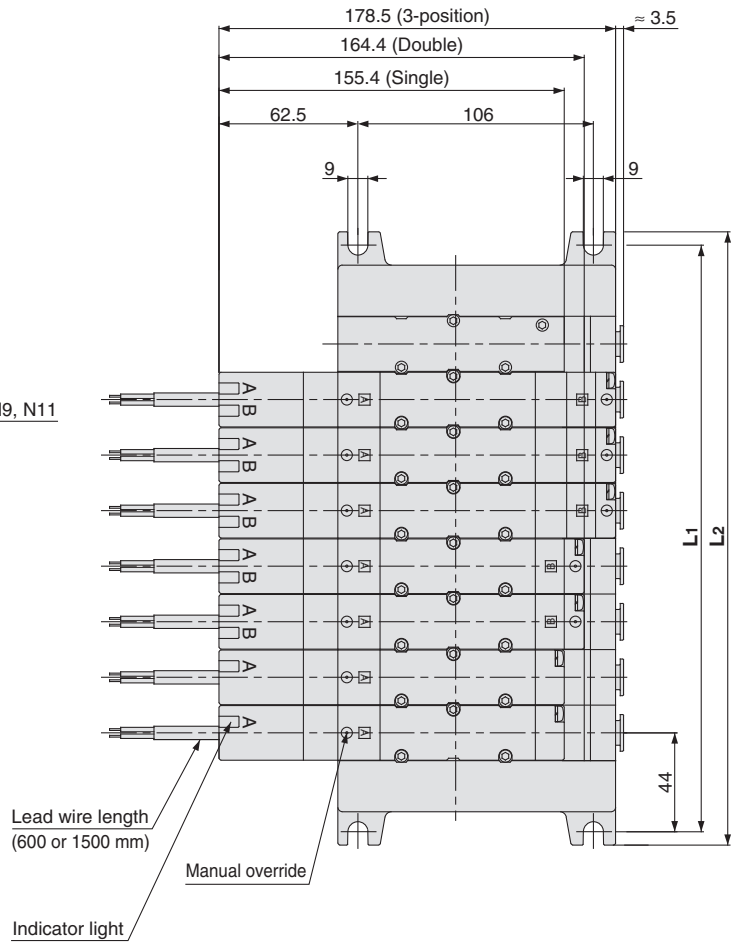
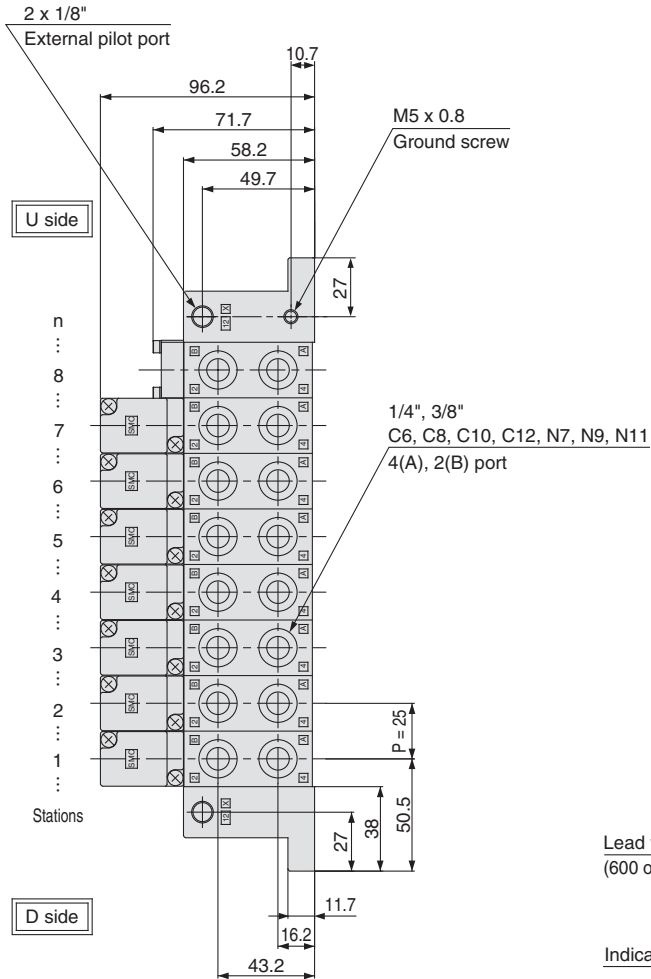

Series VQ4000 Manifold Options

Manifold Option Parts

Blanking plate assembly

VVQ4000-10A-1 (Plug-in type)
VVQ4000-10A-5 (Plug lead type)

It is used by attaching on the manifold block for being prepared for removing a valve for maintenance reasons or planning to mount a spare valve etc.

* Proper tightening torque: 0.5 to 0.7 N·m

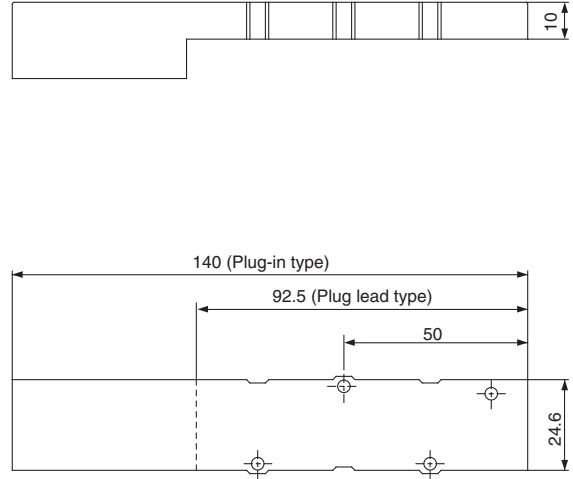
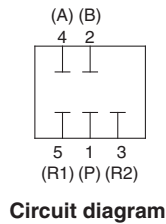
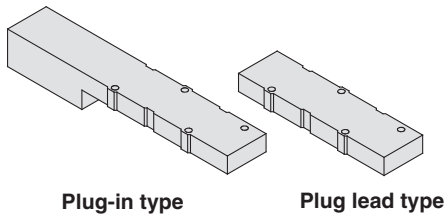

Individual SUP spacer

VVQ4000 - P - 1 - 02

Manifold		Port size		Thread type	
1	Plug-in type	02	1/4	—	Rc
5	Plug lead type	03	3/8	F	G
				N	NPT
				T	NPTF

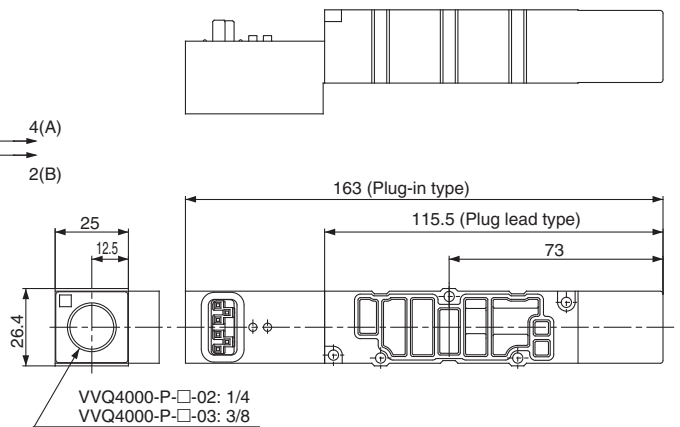
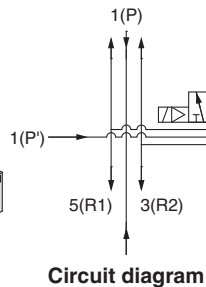
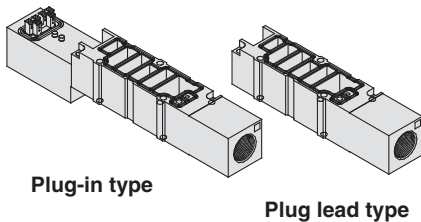

Individual EXH spacer

VVQ4000 - R - 1 - 02

Manifold		Port size		Thread type	
1	Plug-in type	02	1/4	—	Rc
5	Plug lead type	03	3/8	F	G
				N	NPT
				T	NPTF

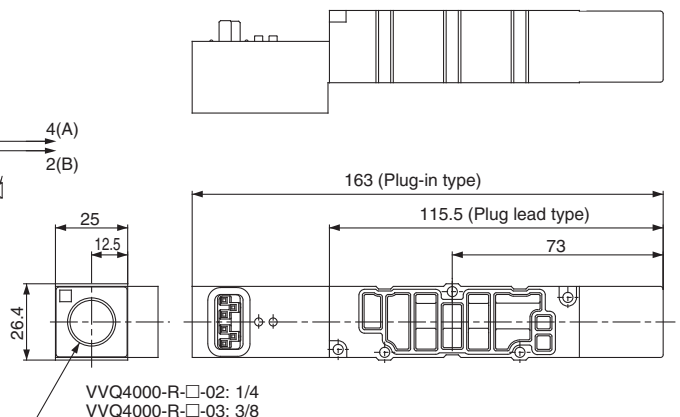
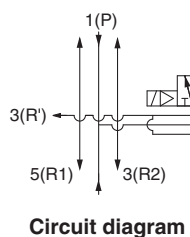
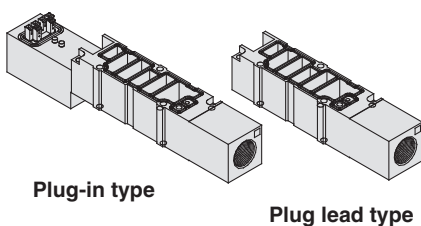

Restrictor spacer

VVQ4000-20A-1 (Plug-in type)
VVQ4000-20A-5 (Plug lead type)

A restrictor spacer is mounted on a manifold block to control cylinder speed by throttling exhaust air flow.

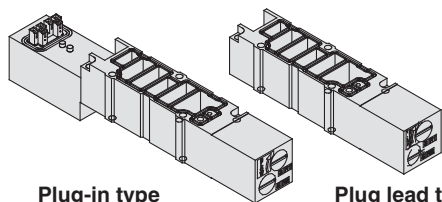

Plug-in type

Plug lead type

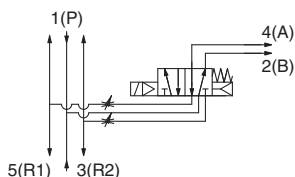

Circuit diagram

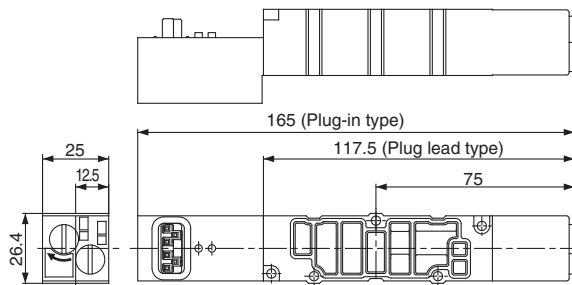

Note 1) A certain amount of leakage is allowed in the products' specifications. Tightening the needle to reduce leakage to zero may result in equipment damage.
Note 2) Products mentioned in this catalogue are retainer types, so the needle is not removed completely. Over rotation will cause damage.

SUP stop valve spacer

VVQ4000-37A-1 (Plug-in type)
VVQ4000-37A-5 (Plug lead type)

A SUP stop valve spacer is mounted on a manifold block, making it possible to individually shut off supply air to each valve.

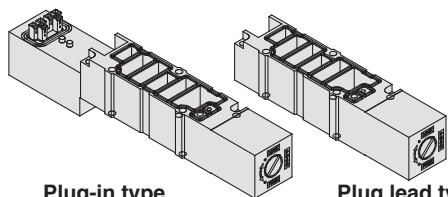

Plug-in type

Plug lead type

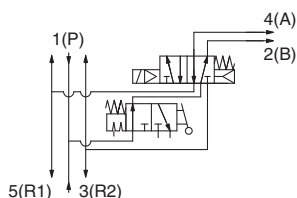

Circuit diagram

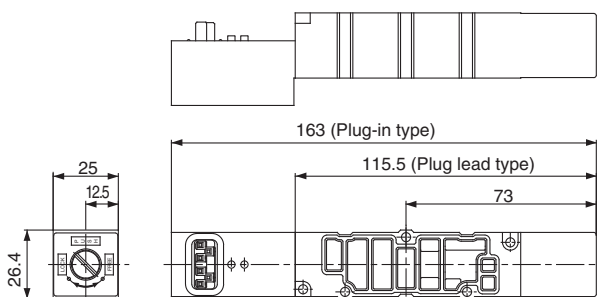

Release valve spacer: For D side mounting

VVQ4000-24A-1D (Plug-in type)
VVQ4000-24A-5D (Plug lead type)

Combination of VQ41□□ (Single) and release valve spacer can be used as air release valve.

Note 1) Mounting on 2-position double and 3-position valve is not possible.
Note 2) Can be mounted on L kit only. For other kits, order E type control unit. (Refer to pages 37 to 40.)

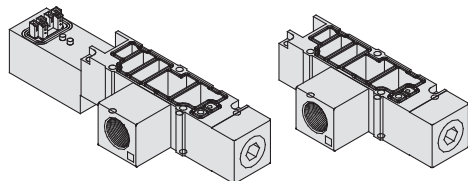

Plug-in type

Plug lead type

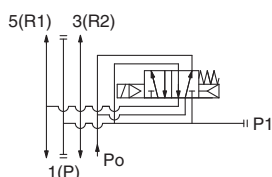

Circuit diagram

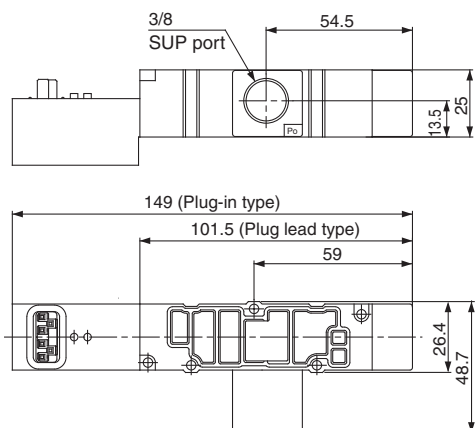

SUP/EXH block plate

VVQ4000-16A

When supplying two different pressures to one manifold, this is used to shut off between stations with different pressures.

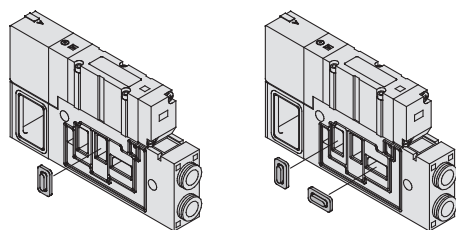

<SUP blocking plate>

<EXH blocking plate>

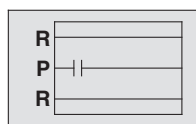

SUP passage blocked

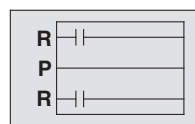

EXH passage blocked

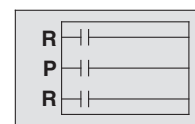

SUP/EXH passage blocked

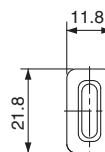

Series VQ4000

Manifold Option Parts

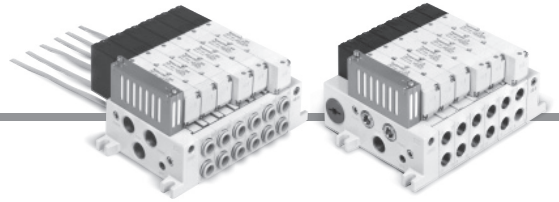

Direct exhaust with silencer box

VV5Q4 $\frac{1}{5}$ -□□□-SB (Exhaust from both sides)

VV5Q4 $\frac{1}{5}$ -□□□-SD (D side exhaust)

VV5Q4 $\frac{1}{5}$ -□□□-SU (U side exhaust)

The EXH outlet is placed on the top side of the manifold end plate. The built-in silencer provides highly effective noise reduction. (Noise reduction of 35 dB(A) or more)

Effective area: 60.2 mm²

Note) Note that when excessive drainage occurs in the air supply, the drainage will be released along with the exhaust.

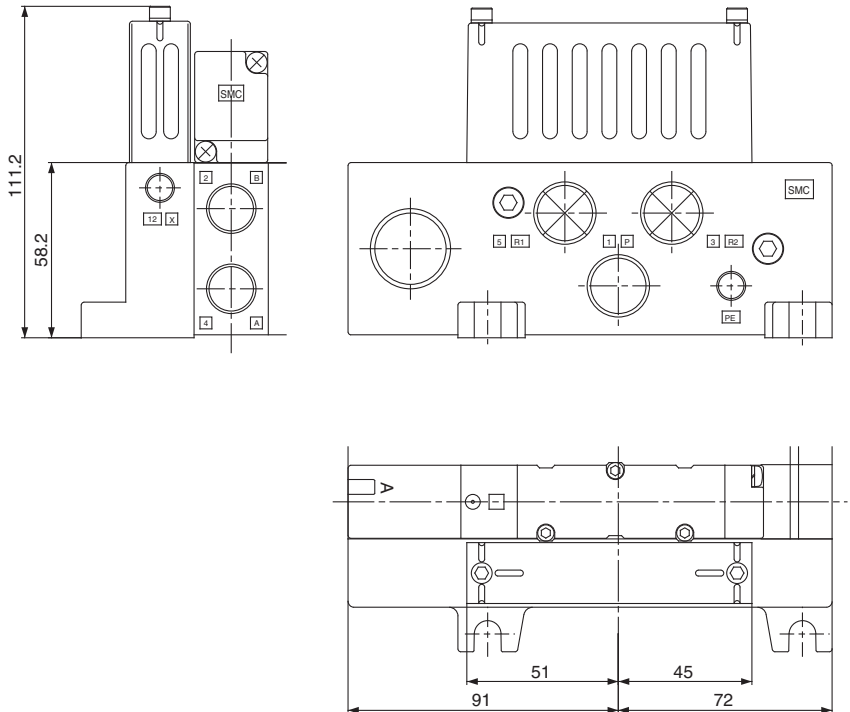
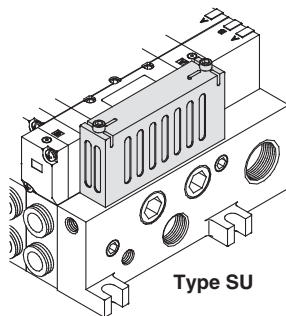
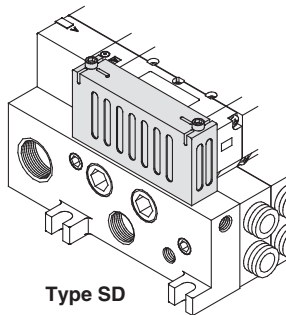

Note) Figure shows VV5Q41-□□□-SD.

- Silencer box assembly: VVQ4000-33A (With gasket, screw)

Double check spacer with residual pressure exhaust

VVQ4000-25A-1 (Plug-in type)

VVQ4000-25A-5 (Plug lead type)

Can hold an intermediate cylinder position for an extended time.

When combined with a double check spacer with built-in double check valve, it is unaffected by air leakage between the spool valves, making it possible to hold a cylinder at an intermediate stopping position for an extended time.

Besides, combination between 2-position solenoid valve (VQ4 $\frac{1}{2}$ □□) and double check spacer cannot hold an intermediate position, but can be used for drop prevention at the cylinder stroke end.

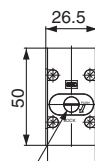

Manual override for residual pressure exhaust
Slotted locking type (Tool required)

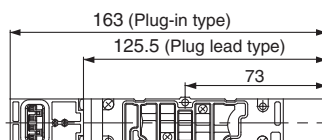
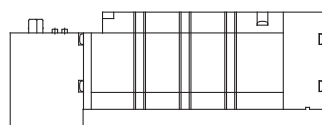
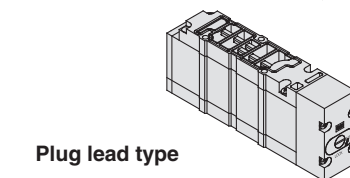
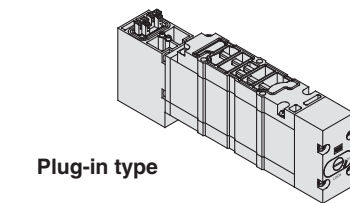

⚠ Caution

Handling Precautions

- In the case of 3-position double check (VQ46 $\frac{1}{5}$ 0), check the leakage from piping and fittings in between valve and cylinder by means of synthetic detergent solutions, and ensure that there is no such leakage found there. Also, check the leakage from cylinder seal and piston seal. If there is any leakage, sometimes the cylinder, when valve is de-energised, can move without stopping at intermediate position.
- Since One-touch fittings allow slight air leakage, screw piping is recommended when stopping the cylinder in the middle for a long time.
- If exhaust side of double check spacer is narrowed down, this causes a decrease in intermediate stop accuracy and may malfunction.
- Combining with 3-position valves "VQ4 $\frac{3}{5}$ □□" is not possible.
- Set the cylinder load so that the cylinder pressure will be within two times that of the supply pressure.
- Combining double check spacer with external pilot is not possible.

Specifications

Double check spacer part no.	VVQ4000-25A- $\frac{1}{5}$	
	Intermediate stop	Drop prevention
Applicable solenoid valve	VQ44□□	VQ4 $\frac{1}{2}$ □□

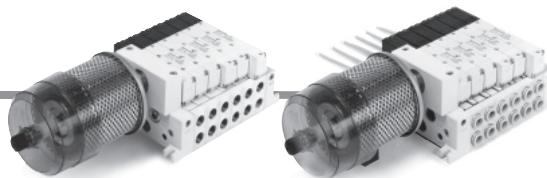

Applicable exhaust cleaner
AMC610-10 (Port size Rc 1)

- Note 1) Exhaust cleaner AMC610-10 is not attached. Please order it separately.
- Note 2) Mount so that the exhaust cleaner is at the lower side.
- Note 3) For details about the exhaust cleaner, refer to the catalogue on SMC website www.smc.eu

Manifold mounted exhaust cleaner

- VV5Q4 $\frac{1}{5}$ -□□□-CD (D side mounting)
- VV5Q4 $\frac{1}{5}$ -□□□-CU (U side mounting)

An adapter plate for exhaust cleaner mounting is provided on the top of the manifold end plate. The exhaust cleaner collects drainage and oil mist (99.9 % or more) and is highly effective for noise reduction.

(Noise reduction of 35 dB(A) or more)

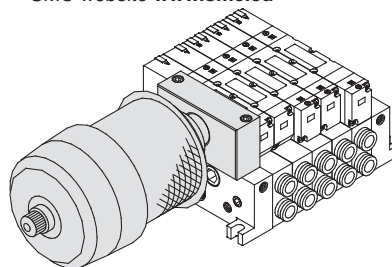
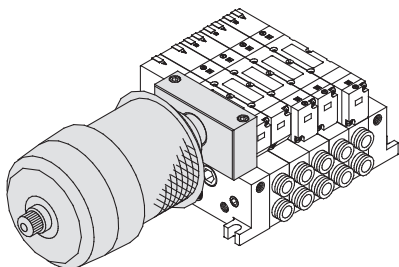

Plug-in type

Plug lead type

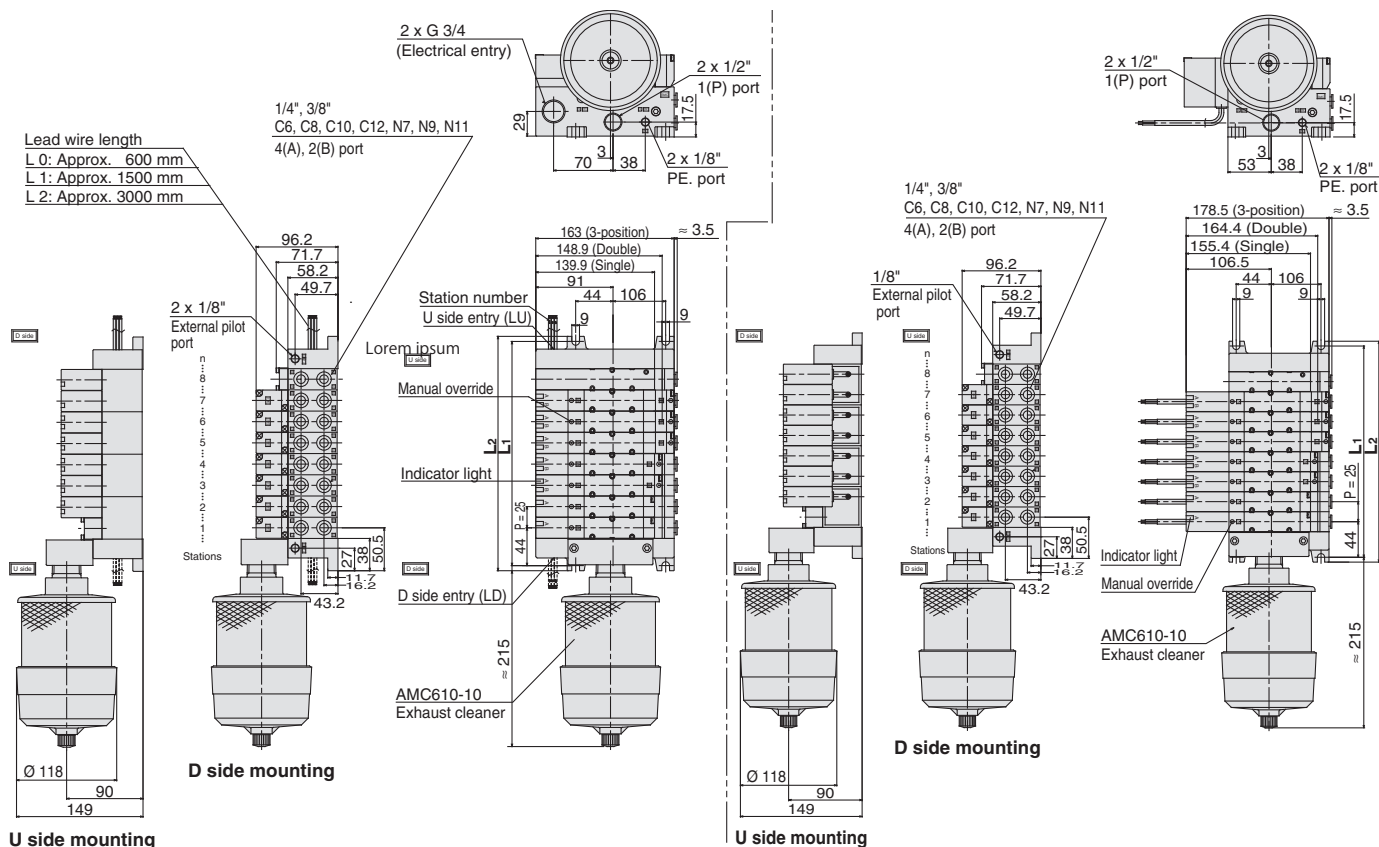

Dimensions

L \ n	1	2	3	4	5	6	7	8
L1	88	113	138	163	188	213	238	263
L2	101	126	151	176	201	226	251	276

L \ n	9	10	11	12	13	14	15	16
L1	288	313	338	363	388	413	463	463
L2	301	326	351	376	401	426	476	476

Formula: L1 = 25n + 63, L2 = 25n + 76
n: Stations (Maximum 16 stations)

Dimensions

L \ n	1	2	3	4	5	6	7	8
L1	88	113	138	163	188	213	238	263
L2	101	126	151	176	201	226	251	276

L \ n	9	10	11	12	13	14	15	16
L1	288	313	338	363	388	413	463	463
L2	301	326	351	376	401	426	476	476

Formula: L1 = 25n + 63, L2 = 25n + 76
n: Stations (Maximum 16 stations)

Series VQ4000

Manifold Option Parts

Interface regulator (P, A, B port regulation)

ARBQ4000-00-□-1 (Plug-in type)

ARBQ4000-00-□-5 (Plug lead type)

Spacer Interface regulators can be placed on top of the manifold block to reduce the pressure of each of the valves.

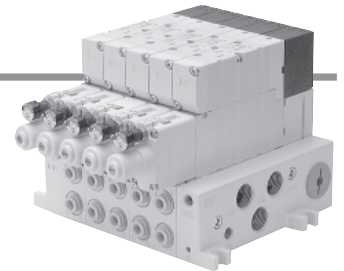

Specifications

Interface regulator		ARBQ4000					
Regulating port		A		B		P	
Applicable valve		Plug-in	Plug lead	Plug-in	Plug lead	Plug-in	Plug lead
Maximum operating pressure		1.0 MPa					
Set pressure range		0.05 to 0.85 MPa					
Fluid		Air					
Ambient and fluid temperature		-5 to 60 °C (No freezing)					
Port size for connection of pressure gauge		M5 x 0.8					
Weight [kg]		0.33	0.30	0.33	0.30	0.33	0.30
Effective area at supply side [mm ²] S at P ₁ = 0.7 MPa/P ₂ = 0.5 MPa	P → A	15		31		14	
	P → B	35		16		15	
Effective area at exhaust side [mm ²] S at P ₂ = 0.5 MPa	A → EA	18		40		40	
	B → EB	37		19		37	

- Note 1) Set the pressure within the operating pressure range of the valve.
 Note 2) Operate an interface regulator only by applying pressure from the P port of the base, except when using it as a reverse pressure valve. When using it as a reverse pressure valve, P port regulation is not allowed to use.
 Note 3) When using a perfect spacer, assemble a valve, a spacer regulator and a perfect spacer in this order to use it.
 Note 4) When using in A port regulation, B port regulation by closed centre, since there is a problem in its operation, please contact SMC.
 Note 5) Dust-tight/Water-jet-proof (IP65) is not available with interface regulator.

How to Order

Valve model	Interface regulator	Regulating port
VQ4□0□ (Plug-in type)	ARBQ4000-00-A-1	A
	ARBQ4000-00-B-1	B
	ARBQ4000-00-P-1	P
VQ4□5□ (Plug lead type)	ARBQ4000-00-A-5	A
	ARBQ4000-00-B-5	B
	ARBQ4000-00-P-5	P

Dimensions

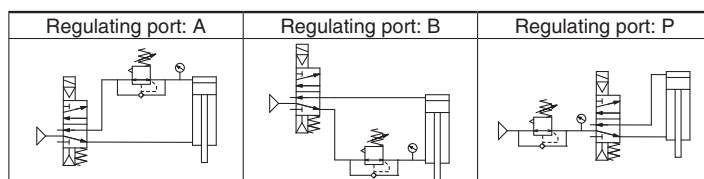
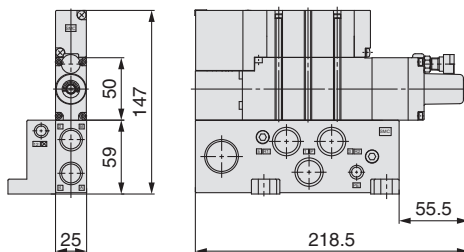

Flow-rate Characteristics

Conditions Inlet pressure: 0.7 MPa

ARBQ4000-00-A

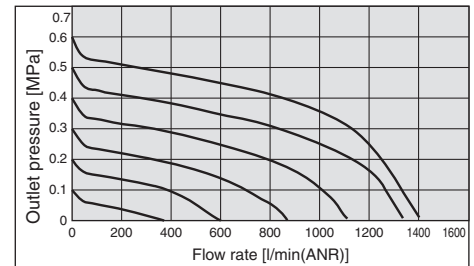

ARBQ4000-00-B

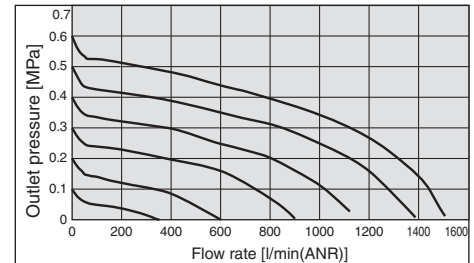

ARBQ4000-00-P (P → A)

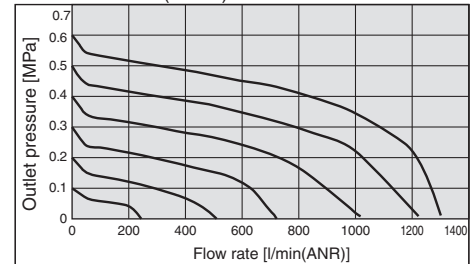

ARBQ4000-00-P (P → B)

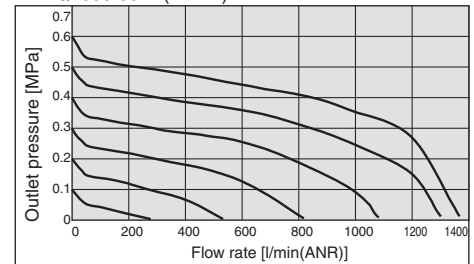

Pressure Characteristics

Conditions

Inlet pressure: 0.7 MPa

Outlet pressure: 0.2 MPa

Flow rate: 20 l/min (ANR)

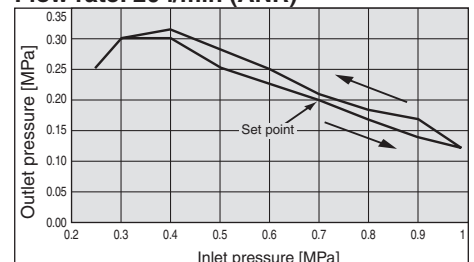

Series VQ4000

Semi-standard Specifications

External Pilot Specifications

- When the supply air pressure is:
 - lower than the required minimum operating pressure 0.15 to 0.2 MPa,
 - opposite air supply (R port supply), cylinder supply (A and B port supply),
 - used for vacuum specification, it can be used for external pilot specification.
 Order a valve by adding the external pilot specification [R] to the part number.
 External pilot is available as standard for manifolds and options.
- Internal/external pilot can be mounted in a manifold.
- Compatibility with universal porting is possible for the single, double and 3-position (excluding double check) types.

Pressure Specifications

Valve construction	Metal seal	Rubber seal
Operating pressure range	-100 kPa to 1.0 MPa	
External pilot pressure range	Single	0.2 to 1.0 MPa
	Double	0.15 to 1.0 MPa
	3-position	0.2 to 1.0 MPa

Combination of manifold options shown below and external pilot specification is not possible.

Release valve spacer	VVQ4000-24A-□D
Manifold with control unit	VV5Q4□-□□□ □ Control unit model no.
Double check spacer with residual pressure exhaust	VVQ4000-25A- $\frac{1}{5}$

How to Order Valves

Sub-plate

Plug-in **VQ4100 [R] - 51 - 03**
 Plug lead **VQ4150 [R] - 5G1 - 03**
 ● External pilot

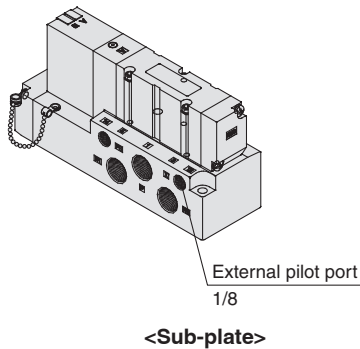

Manifold

Plug-in **VQ4100 [R] - 51**
 Plug lead **VQ4150 [R] - 5G1**
 ● External pilot

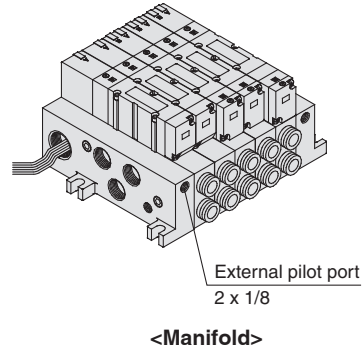

(Note) Possible to mix mounting of internal and external pilot

Series VQ4000 Manifold with Control Unit

- Mounting air filter, regulator, pressure switch for air release valve on manifold as unit is possible and permits piping labour savings.
- Maximum number of stations depends on each kit.
Refer to manifold specifications.
- 2 stations are used for control unit mounting.
(1 station is used for E type.)

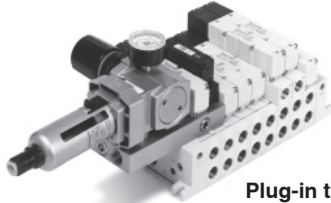

Plug-in type

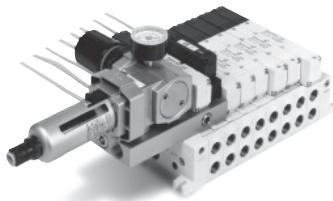

Plug lead type

Caution

In the case of air filters with auto-drain or manual drain, mount so that the air filter is at the bottom.

Manifold Specifications

Base model	Type of connection	4(A), 2(B) port location	Porting specifications		Applicable max. stations ^{Note)}	Applicable valve
			Port size	1(P), 5(R1), 3(R2)		
VV5Q41 -□□□	F kit – D-sub connector T kit – Terminal block box L kit – Lead wire	Side	1/2	C6 (for ø6) C8 (for ø8) C10 (for ø10) C12 (for ø12) 1/4, 3/8 N7 (for ø1/4") N9 (for ø5/16") N11 (for ø3/8")	F, T kit 14 stations (13 stations) L, C kit 18 stations (17 stations)	VQ4□00 VQ4□01
			Option (Direct exhaust with silencer box)			
VV5Q45 -□□□	C kit – Connector	Bottom		1/4		VQ4□50 VQ4□51

Note) Manifold for mounting is included. () : E type

Control Unit Specifications

Air filter (With auto-drain/With manual drain)	
Filtration	5 µm
Regulator	
Set pressure (Outlet pressure)	0.05 to 0.85 MPa
Pressure switch ^{Note 1)}	
Set pressure range: OFF	0.1 to 0.6 MPa
Differential	0.08 MPa or less
Contact	1a
Light	LED (RED)
Max. switch capacity	2 VA (AC), 2 W (DC)
Max. operating current	50 mA at 24 VAC, DC or less 20 mA at 100 VAC, DC
Air release valve (Single only)	
Operating pressure range	0.15 to 1 MPa

Control Unit/Option

Air release valve	VQ41 ⁰⁰ ₅₁ Y-5 ^(G) _(H) 1(-Q)		
Air release valve spacer ^{Note 2)}	<Plug-in type> VVQ4000-24A-1D		
	<Plug lead type> VVQ4000-24A-5D		
Pressure switch	IS1000P-2-1		
Blanking plate ^{Note 3)}	Regulator with filter	MP2-3	
	Pressure switch	MP3-2	
	Release valve	Plug-in	VVQ4000-24A-10
Filter element	Plug lead	VVQ4000-24A-15	
	INA-13-854-12-5B		

Note 1) Rated voltage: 24 VDC to 100 VAC
Internal voltage drop: 4 V

Note 2) Combination of VQ41□□ (Single) and release valve spacer can be used as air release valve.

Note 3) Plug lead type can not be mounted later.

How to Order



VV5Q 4 1 - 08 C8 [] F U1 [] [] - [] - Q

Series	
4	VQ4000
Manifold	
1	Plug-in unit
5	Plug lead unit
Stations	
02	2 stations
⋮	⋮

Maximum and minimum number of stations depend on the kit.

Cylinder port	
C6	Ø 6 One-touch fitting
C8	Ø 8 One-touch fitting
C10	Ø 10 One-touch fitting
C12	Ø 12 One-touch fitting
02	1/4
03	3/8
B	Bottom ported 1/4
CM	Mixed
N7	Ø 1/4" One-touch fitting
N9	Ø 5/16" One-touch fitting
N11	Ø 3/8" One-touch fitting

Thread type

—	Rc
F	G
N	NPT
T	NPTF

Kit ^{Note 5)}	
—	Without air release valve (Only F, G type)
5	24 V DC
Air release valve coil rating	
—	Without air release valve (Only F, G type)
5	24 V DC

Control unit type

Control equipment	Symbol	—	A	AP	M	MP	F	G	C	E
Air filter with auto-drain			●	●			●			
Air filter with manual drain					●	●		●		
Regulator			●	●	●	●	●	●		
Air release valve			●	●	●	●			●	●
Pressure switch				●		●				
Blanking plate (Air release valve)							●	●		
Blanking plate (Filter, Regulator)									●	
Blanking plate (Pressure switch)			●		●		●	●	●	
Necessary number of manifold blocks for mounting (Stations)			2 stations	2 stations	2 stations	2 stations	2 stations	2 stations	2 stations	1 station

Note) Electrical entry: Control unit cannot be removed except L and C kits.

Use of Control Unit

<Construction and piping>

- The supply pressure (P_o) passes through the filter regulator (1) and is adjusted to the prescribed pressure. Next, it goes through the release valve (2) (outlet residual pressure switching function used as normally ON) and is supplied to the manifold base side (P).
- Supply pressure from P_o port is blocked when release valve (2) is OFF. Air supplied to manifold side P port is exhausted to R1 port through release valve (2).
- Pressure switch is piped at outlet side of release valve (2). (Release valve (2) is operated at energizing.)
Also, since there is an internal voltage drop of 4 V, it may not be possible to confirm the OFF and ON states with a tester, etc.

<Wiring>

- Electrical entry of manifold (except L and C kit) is individual wiring. For details, refer to internal wiring figure of each kit. Cable length is 0.6 m for L kit.

<Change of pressure switch piping>

- Pressure switch (3) is changed to piping on inlet side of release valve (2), remove the pressure switch, reverse the gasket up and down, and fix [B] mark.
- When pressure switch is mounted, tightening torque of bolt is 0.8 to 1.2 N·m.

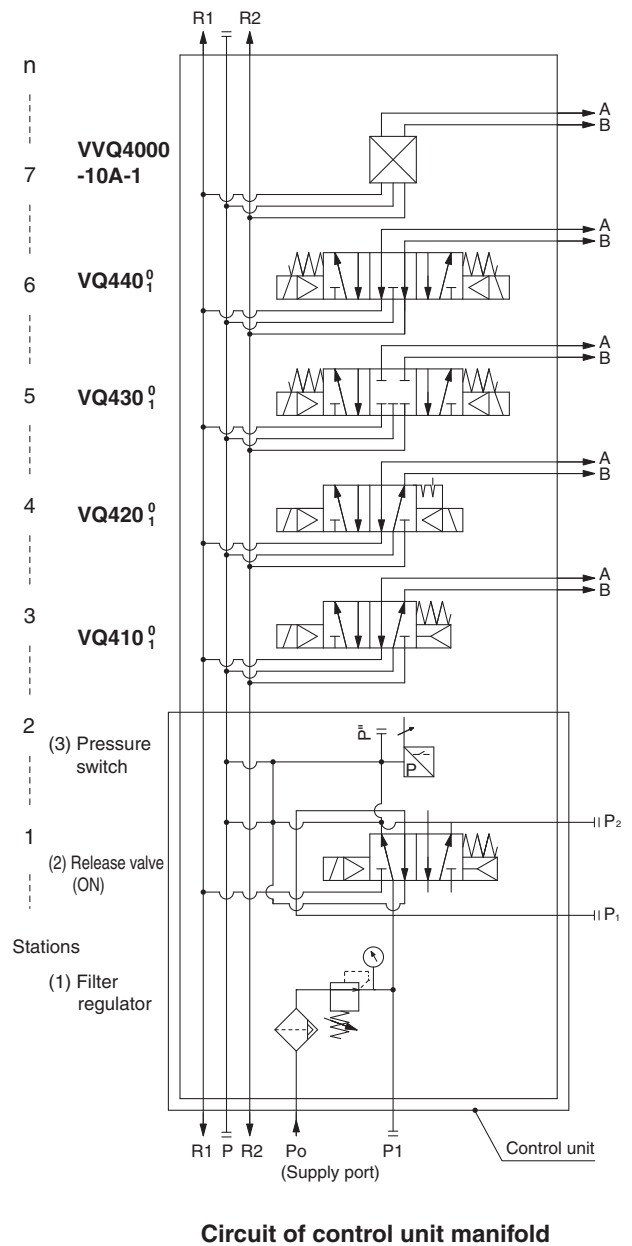
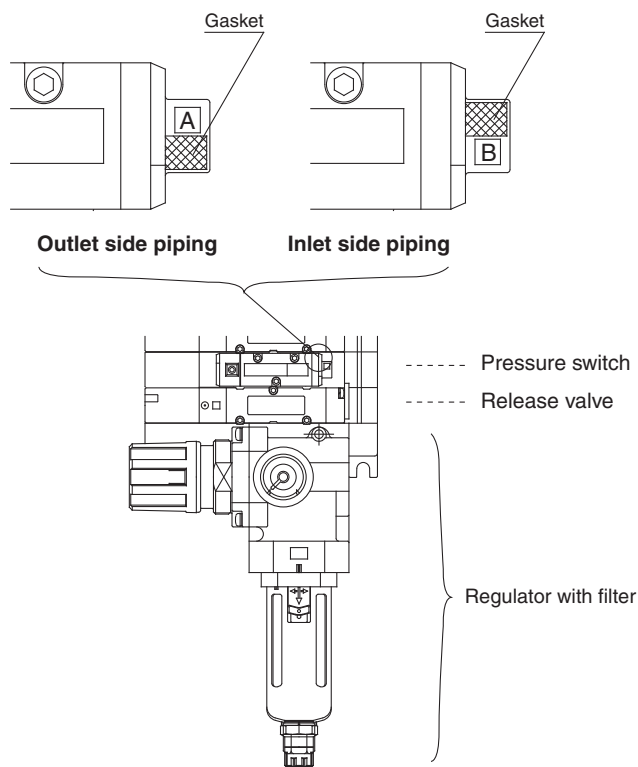

Series VQ4000

Dimensions

Plug-in type

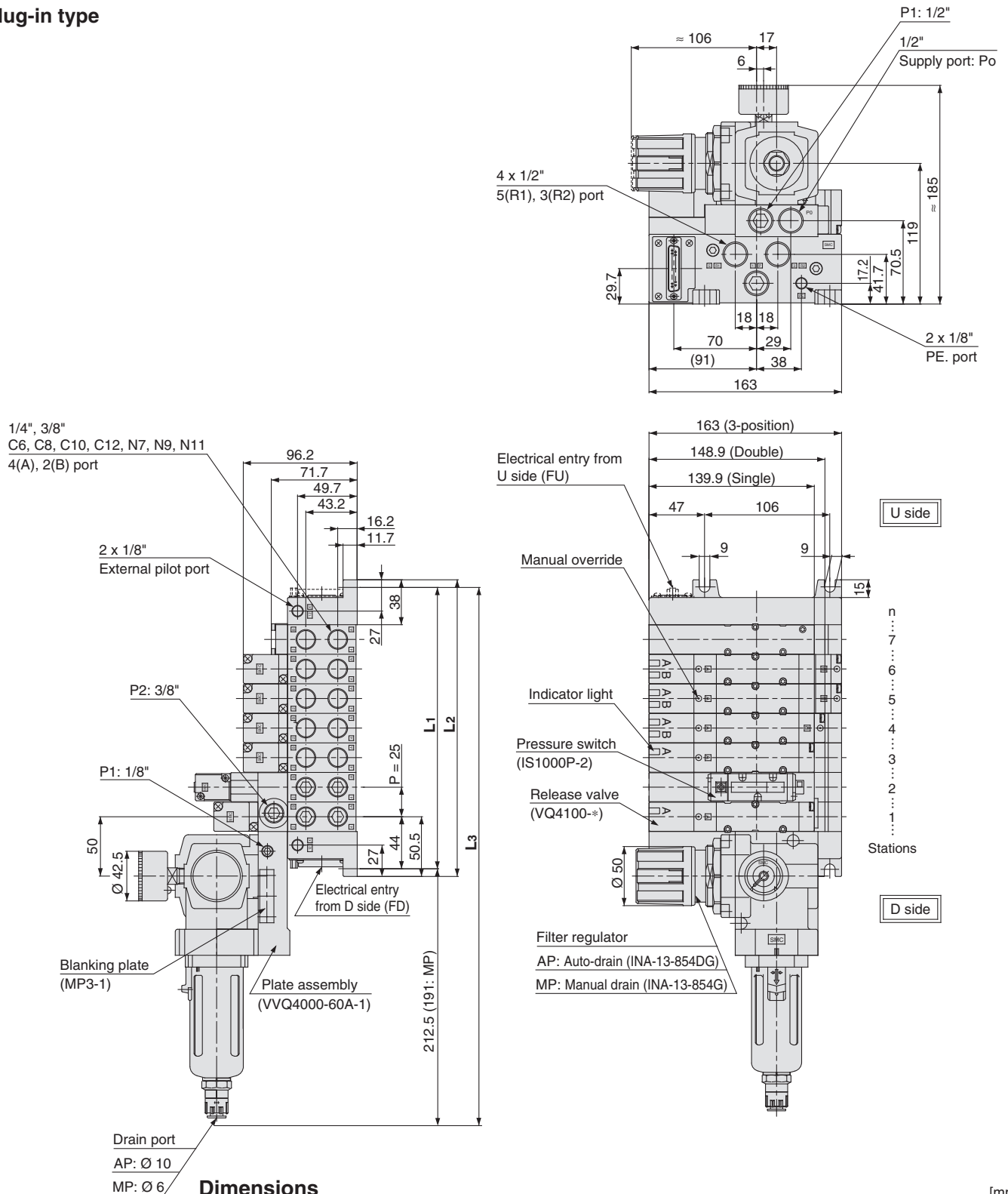

Dimensions

L \ n	2	3	4	5	6	7	8	9	10	11	12
L1	113	138	163	188	213	238	263	288	313	338	363
L2	126	151	176	201	226	251	276	301	326	351	376
L3	332	357	382	407	432	457	482	507	532	557	582
	(310.5)	(335.5)	(360.5)	(385.5)	(410.5)	(435.5)	(460.5)	(485.5)	(510.5)	(535.5)	(560.5)

Formula: L1 = 25n + 63, L2 = 25n + 76, L3 = 25n + 282 (260.5) n: Stations

* L3 (): Type MP

Plug lead type

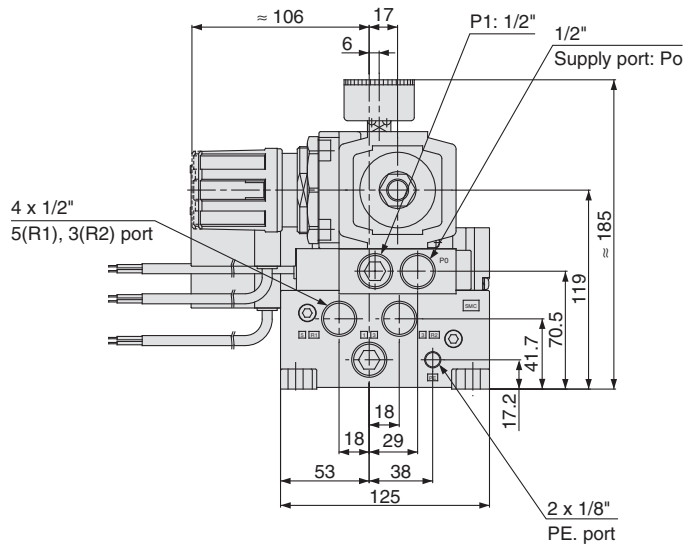
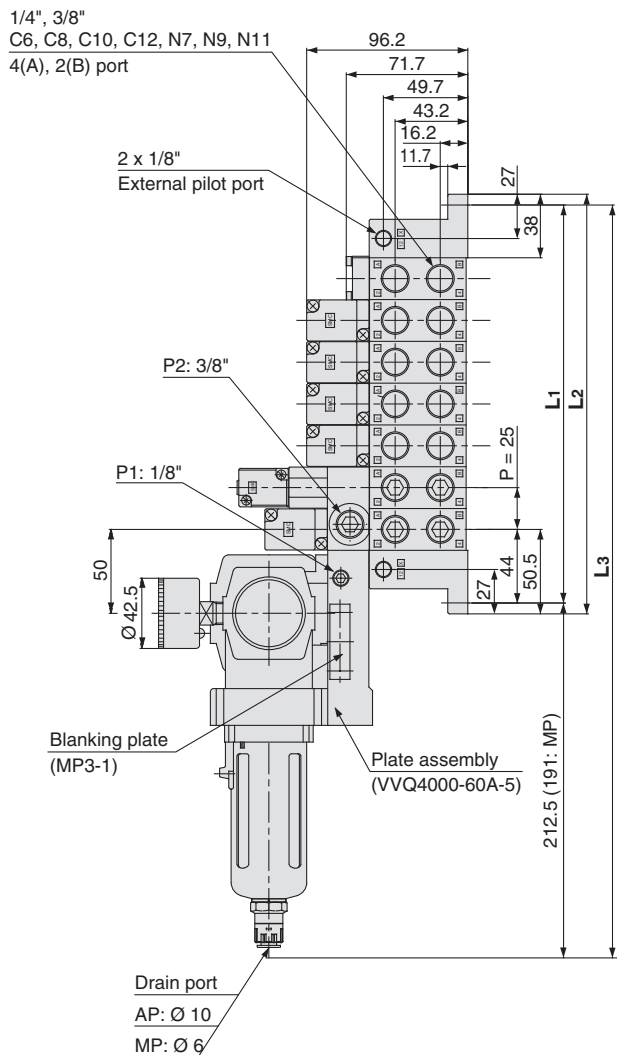

U side

D side

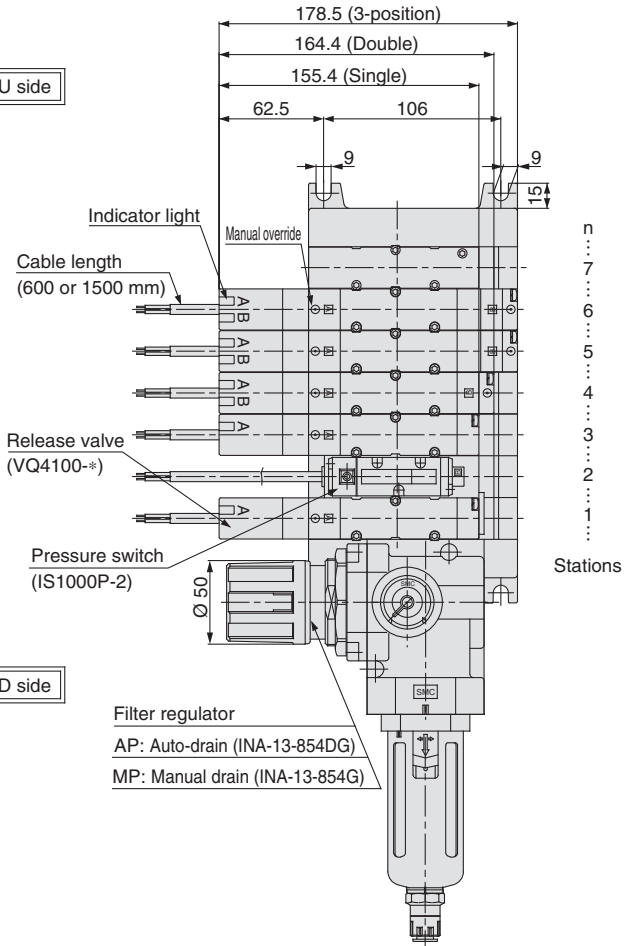

Dimensions

L \ n	2	3	4	5	6	7	8	9	10	11	12
L1	113	138	163	188	213	238	263	288	313	338	363
L2	126	151	176	201	226	251	276	301	326	351	376
L3	332	357	382	407	432	457	482	507	532	557	582
	(310.5)	(335.5)	(360.5)	(385.5)	(410.5)	(435.5)	(460.5)	(485.5)	(510.5)	(535.5)	(560.5)

Formula: L1 = 25n + 63, L2 = 25n + 76, L3 = 25n + 282 (260.5) n: Stations

* L3 (): Type MP

VQ4000

Manifold Options

Semi-standard Specifications

Manifold with Control Unit

Construction

Exploded View of Manifold

VQ5000

Manifold Options

Semi-standard Specifications

Construction

Exploded View of Manifold

Series VQ4000 Construction

Plug-in Unit

Metal seal type

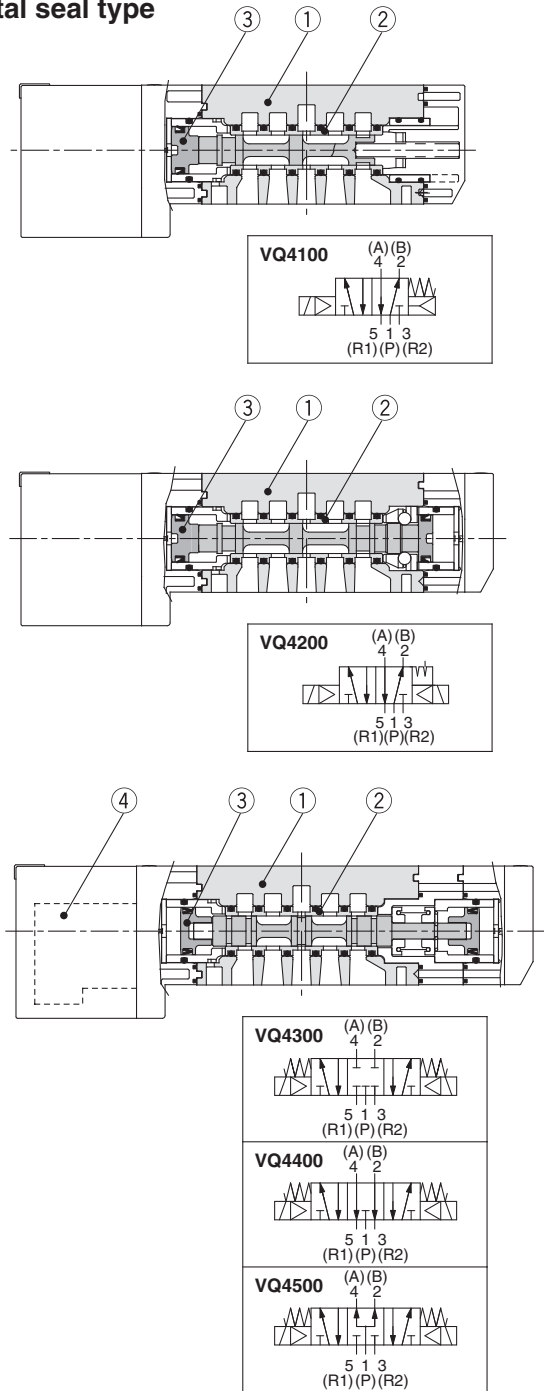

Component Parts

Number	Description	Material	Note
1	Body	Aluminium die-casted	
2	Spool/Sleeve	Stainless steel	
3	Piston	Resin	

Replacement Parts

4	Pilot valve assembly	<p>V118□□-□-□-□ A B E</p> <p>□: Coil rated voltage Example) 24 VDC: 5 A: With light (For A side) B: With light (For B side) E: Without light (A/B side common)</p> <p>●Coil type</p> <table border="1"> <tr> <td>—</td> <td>Standard (0.95 W)</td> </tr> <tr> <td>Y</td> <td>Low wattage type (0.4 W)</td> </tr> </table>	—	Standard (0.95 W)	Y	Low wattage type (0.4 W)
—	Standard (0.95 W)					
Y	Low wattage type (0.4 W)					

Rubber seal type

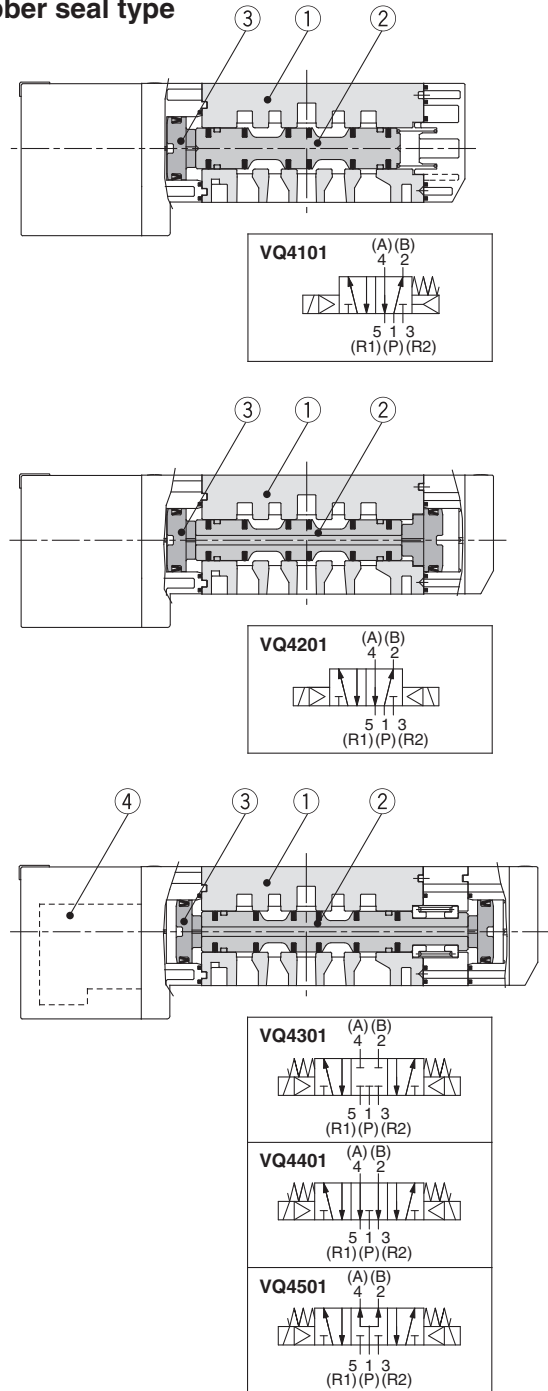

Component Parts

Number	Description	Material	Note
1	Body	Aluminium die-casted	
2	Spool valve	Aluminium, HNBR	
3	Piston	Resin	

Replacement Parts

4	Pilot valve assembly	<p>V118□□-□-□-□ A B E</p> <p>□: Coil rated voltage Example) 24 VDC: 5 A: With light (For A side) B: With light (For B side) E: Without light (A/B side common)</p> <p>●Coil type</p> <table border="1"> <tr> <td>—</td> <td>Standard (0.95 W)</td> </tr> <tr> <td>Y</td> <td>Low wattage type (0.4 W)</td> </tr> </table>	—	Standard (0.95 W)	Y	Low wattage type (0.4 W)
—	Standard (0.95 W)					
Y	Low wattage type (0.4 W)					

Plug Lead Unit

Metal seal type

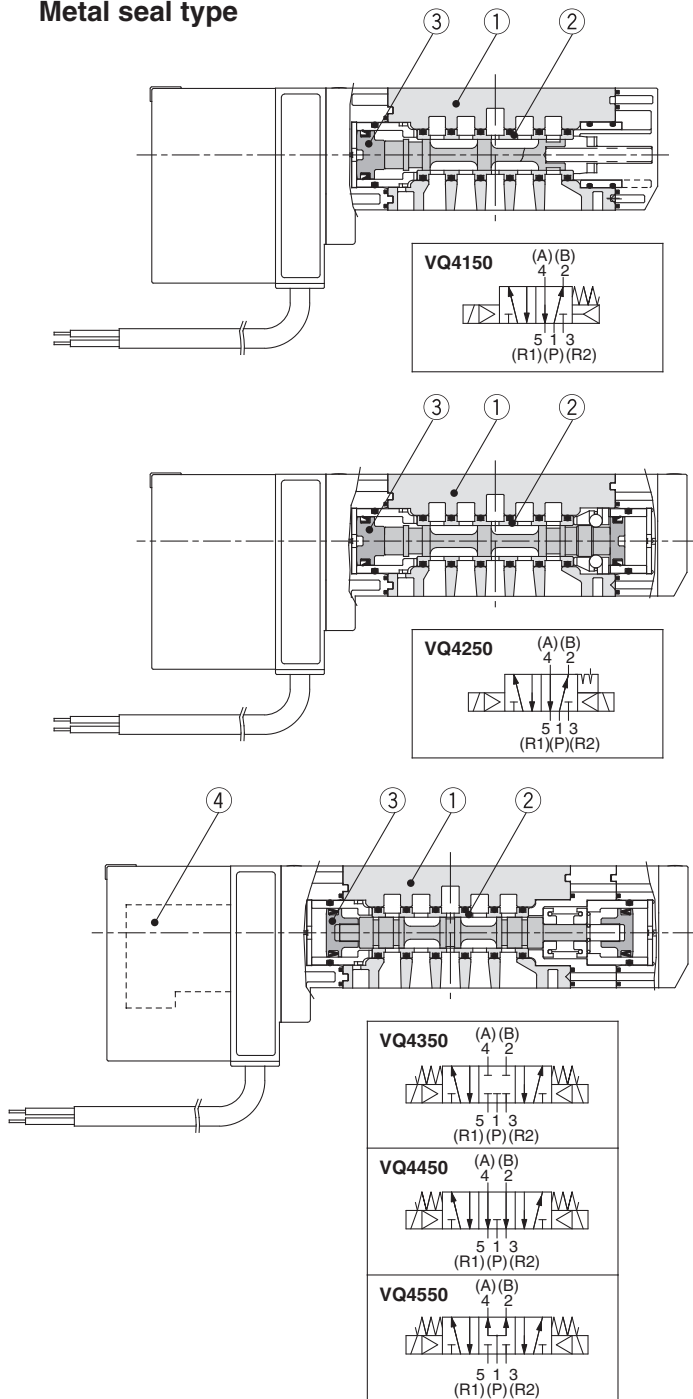

Component Parts

Number	Description	Material	Note
1	Body	Aluminium die-casted	
2	Spool/Sleeve	Stainless steel	
3	Piston	Resin	

Replacement Parts

4	Pilot valve assembly		□: Coil rated voltage Example) 24 VDC: 5 A: With light (For A side) B: With light (For B side) E: Without light (A/B side common)
		Coil type — Standard (0.95W) Y Low wattage type (0.4W)	

Rubber seal type

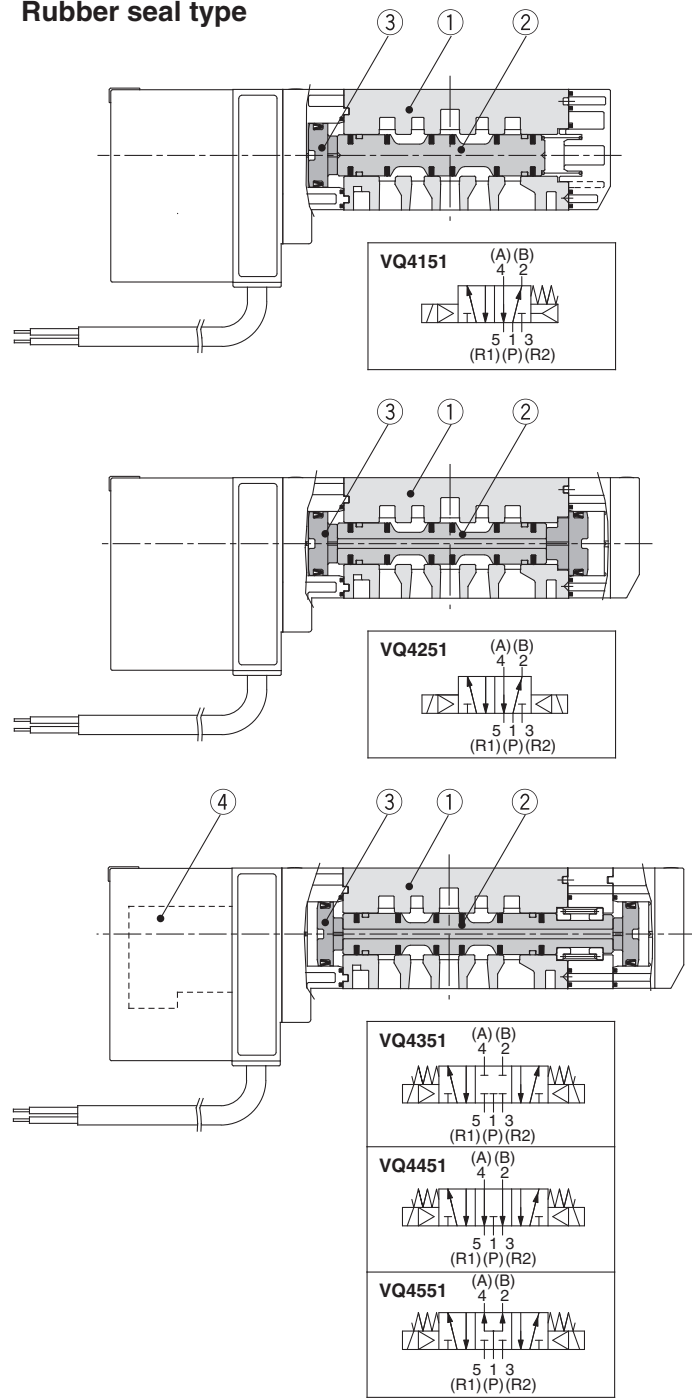

Component Parts

Number	Description	Material	Note
1	Body	Aluminium die-casted	
2	Spool valve	Aluminium, HNBR	
3	Piston	Resin	

Replacement Parts

4	Pilot valve assembly		□: Coil rated voltage Example) 24 VDC: 5 A: With light (For A side) B: With light (For B side) E: Without light (A/B side common)
		Coil type — Standard (0.95W) Y Low wattage type (0.4W)	

VQ4000

Manifold Options

Semi-standard Specifications

Manifold with Control Unit

Construction

Exploded View of Manifold

VQ5000

Manifold Options

Semi-standard Specifications

Construction

Exploded View of Manifold

Series VQ4000

Exploded View of Manifold

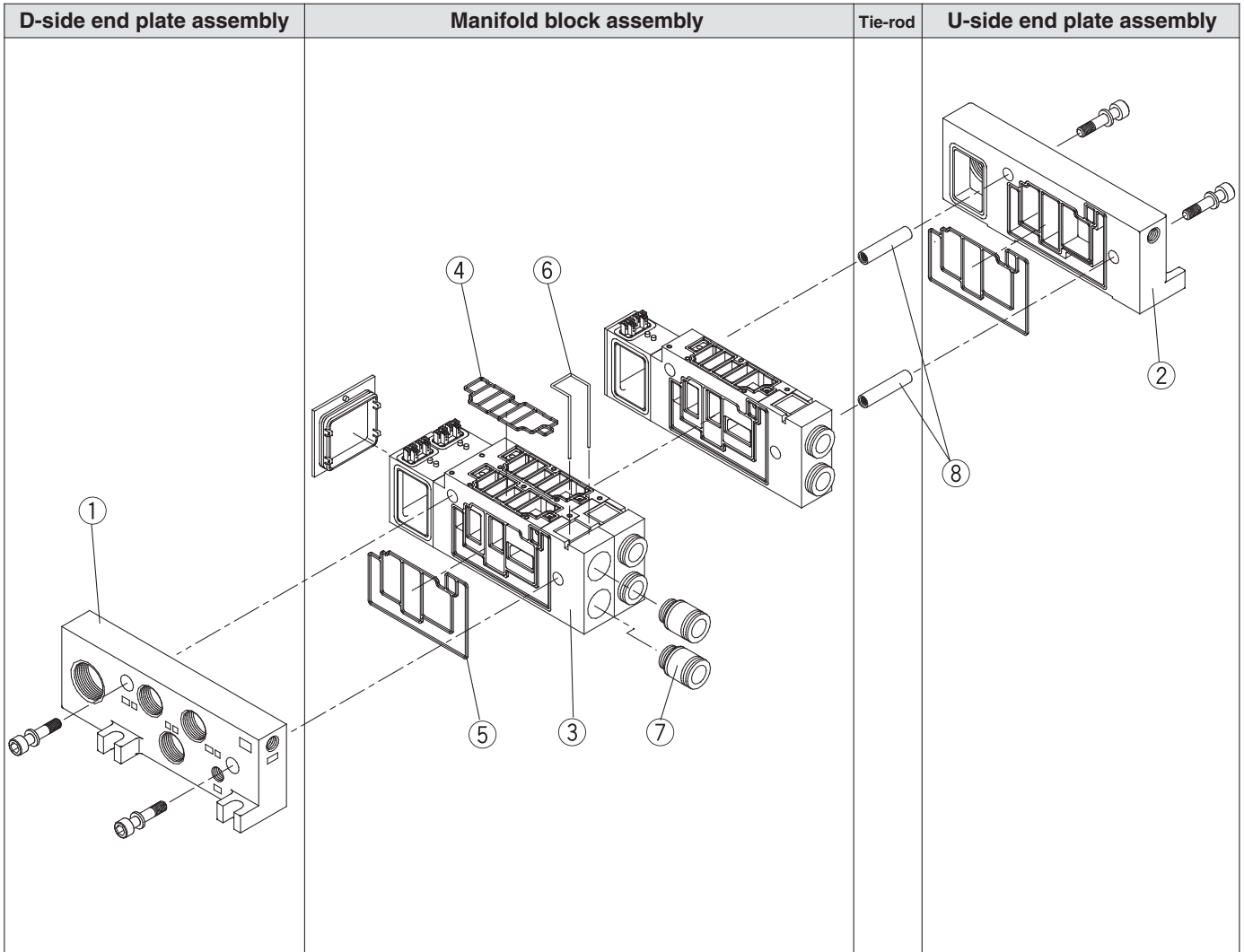

Note) The electrical entry cannot be changed.

Figure shows a plug-in type.

D side

U side

Example) 1.....2.....3.....4.....5.....6.....Stations

5 stations (Odd number) 2 stations | 2 stations | 1 station

6 stations (Even number) 2 stations | 2 stations | 2 stations

D-Side End Plate Assembly

1. D-side end plate assembly part no. (For F, L, S, T kit)

VVQ4000 - 3A - 1 - - -

Thread type

—	Rc
N	NPT
T	NPTF
F	G

Option 1

—	Standard
CD	For exhaust cleaner mounting
SD	Direct exhaust with silencer box

Electrical entry

L	F, L, S, T kit
F ^{Note 1)}	F kit (Connector location on D side)
C	C kit (Plug lead type)

Note 1) D-sub connector assembly for D side: VVQ4000-19A-D is not included. (Order separately)

Option 2

—	Standard
W ^{Note 2)}	IP65 enclosure

Note 2) Drip proof type for F kit is not available.

D-sub connector assembly

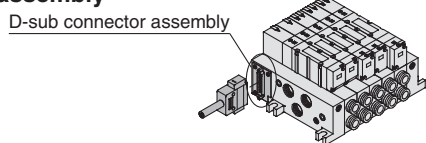

VVQ4000 - 19A -

D	D side entry
U	U side entry

Manifold Block Assembly

3. Manifold block assembly part no. (Including ④, ⑤ and ⑥)

VVQ4000 - 1 - - - -

Type

A	For 1 station
C	For 2 stations ^{Note 3)}

Port thread type

—	Rc
N	NPT
T	NPTF
F	G

Option

—	Standard
W ^{Note 2)}	IP65 enclosure

Electrical entry

F1	F kit Double wiring
F2	F kit Single wiring
T1	T kit Double wiring
T2	T kit Single wiring
S1	S kit Double wiring
S2	S kit Single wiring
L0 <input type="checkbox"/>	L0 kit <input type="checkbox"/> : Stations (1 to 16)
L1 <input type="checkbox"/>	L1 kit <input type="checkbox"/> : Stations (1 to 16)
L2 <input type="checkbox"/>	L2 kit <input type="checkbox"/> : Stations (1 to 16)
C	C kit (Plug lead type)

Port size

O2	1/4
O3	3/8
B	Bottom ported 1/4 ^{Note 4)}
C6	With One-touch fitting for Ø 6
C8	With One-touch fitting for Ø 8
C10	With One-touch fitting for Ø 10
C12	With One-touch fitting for Ø 12
N7	With One-touch fitting for Ø 1/4
N9	With One-touch fitting for Ø 5/16
N11	With One-touch fitting for Ø 3/8

Note 1) Tie-rods (2 pcs.) and lead wire assembly for station addition included.
 Note 2) Dripproof F kit is not available.
 Note 3) When ordering block assembly for L kit 2 stations, the lead wire should be ordered by the smaller numbers of the D side (no. of station).
 Note 4) Bottom ported type: For 1-station type only.

Housing Assembly and SI Unit

Kit type	Model symbol	Part no.	Description
S (Serial transmission unit)	O	—	Without SI Unit
	Q	EX124 _U -SDN1	DeviceNet (2 power supply systems)
	R1	EX124 _U -SCS1	OMRON Corp.: CompoBus/S (16 output points, 2 power supply systems)
	R2	EX124 _U -SCS2	OMRON Corp.: CompoBus/S (8 output points, 2 power supply systems)
	V	EX124 _U -SMJ1	CC-Link (2 power supply systems)
T (Terminal block box kit)	—	VVQ5000-70A- _U (-W)	—

U-Side End Plate Assembly

2. U-side end plate assembly part no. (For F, L, S, T kit)

VVQ4000 - 2A - 1 - - -

Thread type

—	Rc
N	NPT
T	NPTF
F	G

Option 1

—	Standard
CU	For exhaust cleaner mounting
SU	Direct exhaust with silencer box

Electrical entry

L	F, L, S, T kit
F ^{Note 1)}	F kit (Connector location on U side)
C	C kit (Plug lead type)

Note 1) D-sub connector assembly for U side: VVQ4000-19A-U is not included. (Order separately)

Option 2

—	Standard
W ^{Note 2)}	IP65 enclosure

Note 2) Drip proof type for F kit is not available.

Manifold Block Replacement Parts

Replacement Parts

No.	Part no.	Description	Material	Q'ty
④	VVQ4000-80A-1	Gasket	HNBR	10
⑤	VVQ4000-80A-2	Gasket	HNBR	10
⑥	VVQ4000-80A-4	Clip	Stainless steel	10

Note) Spare parts consist of sets containing 10 pcs. each.

Fitting Assembly

7. Fitting assembly part no. (For cylinder port)

VVQ4000 - 50B -

Port size

C6	Applicable tubing Ø 6
C8	Applicable tubing Ø 8
C10	Applicable tubing Ø 10
C12	Applicable tubing Ø 12
N7	Applicable tubing Ø 1/4
N9	Applicable tubing Ø 5/16
N11	Applicable tubing Ø 3/8

Note) Purchasing order is available in units of 10 pieces.

8. Tie-rods part no. (2 pcs.)

VVQ4000 - TR -

Stations: O2 to 18

Note) When eliminating manifold stations, order this separately. When increasing manifold stations, it is not necessary to order since tie-rods are included in the manifold block assembly.

Series VQ4000

List of Valves, Options, and Mounting Bolts

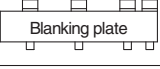
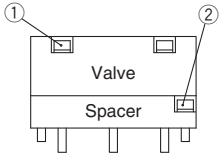
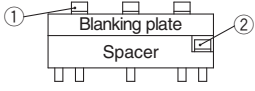
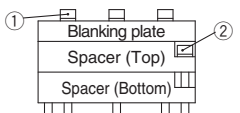
Number of options	Valve and options	Bolt part no. Proper tightening torque: 0.8 to 1.2 N·m	Qty (pcs.)	Note	Option mounting diagram
0	Single valve	AXT632-17-4 (M3 x 37)	3		
	Blanking plate (VVQ4000-10A- $\frac{1}{5}$)	AXT632-38-1 (M3 x 14) <i>Note 2)</i>	4	For manifold	
1	Valve + Individual SUP spacer (VVQ4000-P- $\frac{1}{5}$ - $\frac{02}{03}$)	① AXT632-17-10 (M3 x 62)	3	For manifold	
		② AXT632-17-19 (M3 x 26)	2		
	Valve + Individual EXH spacer (VVQ4000-R- $\frac{1}{5}$ - $\frac{02}{03}$)	① AXT632-17-10 (M3 x 62)	3	For manifold	
		② AXT632-17-19 (M3 x 26)	2		
	Valve + Restrictor spacer (VVQ4000-20A- $\frac{1}{5}$)	① AXT632-17-10 (M3 x 62)	3	Not necessary when mounting the sub-plate.	
		② AXT632-17-19 (M3 x 26)	2		
	Valve + Release valve spacer (VVQ4000-24A- $\frac{1}{5}$ D)	① AXT632-17-10 (M3 x 62)	3	For manifold	
		② AXT632-17-19 (M3 x 26)	2		
	Valve + SUP stop valve spacer (VVQ4000-37A- $\frac{1}{5}$)	① AXT632-17-10 (M3 x 62)	3	Not necessary when mounting the sub-plate.	
		② AXT632-17-19 (M3 x 26)	2		
Valve + Double check spacer with residual pressure exhaust (VVQ4000-25A- $\frac{1}{5}$)	① AXT632-17-11 (M3 x 87)	3	Not necessary when mounting the sub-plate.		
	② AXT632-41-1 (M3 x 54) <i>Note 2)</i>	2			
Valve + Interface regulator (ARBQ4000-00 $\frac{A}{P}$ - $\frac{1}{5}$)	① AXT632-17-11 (M3 x 87)	3	Not necessary when mounting the sub-plate.		
	② AXT632-17-8 (M3 x 52)	2			
Blanking plate + SUP stop valve (Top) (Bottom)	① AXT632-41-4 (M3 x 42) <i>Note 2)</i>	3	For manifold		
	② AXT632-17-19 (M3 x 26)	2			
2	Valve + Individual SUP + Individual EXH (Top) (Bottom) (Bottom) (Top)	① AXT632-17-11 (M3 x 87)	3		For manifold
		② AXT632-17-8 (M3 x 52)	2		
	Valve + Restrictor + Individual SUP or Individual EXH (Top) (Bottom) (Top) (Bottom)	① AXT632-17-11 (M3 x 87)	3		For manifold The individual EXH cannot be mounted on the top.
		② AXT632-17-8 (M3 x 52)	2		
	Valve + SUP stop valve + Individual SUP, Individual EXH or Restrictor (Top) (Bottom)	① AXT632-17-11 (M3 x 87)	3		For manifold
		② AXT632-17-8 (M3 x 52)	2		
	Valve + Double check spacer with + Individual SUP or residual pressure exhaust Individual EXH (Top) (Bottom)	① AXT632-17-14 (M3 x 112)	3		For manifold
		② AXT632-41-2 (M3 x 78) <i>Note 2)</i>	2		
Valve + Interface regulator + Individual SUP, Individual EXH or Restrictor (Top) (Bottom)	① AXT632-17-14 (M3 x 112)	3	For manifold The individual EXH and restrictor can be mounted on the top.		
	② AXT632-41-2 (M3 x 78)	2			
Valve + Restrictor + Double check spacer with residual pressure exhaust (Top) (Bottom)	① AXT632-17-14 (M3 x 112)	3	For manifold		
	② AXT632-41-2 (M3 x 78)	2			
Valve + Interface regulator+ Double check spacer with residual pressure exhaust (Top) (Bottom)	① AXT632-17-16 (M3 x 137)	3	For manifold		
	② AXT632-41-3 (M3 x 103)	2			
Blanking plate + SUP stop valve + Individual SUP (Top) (Bottom)	① AXT632-17-17 (M3 x 66) <i>Note 2)</i>	3	For manifold		
	② AXT632-17-8 (M3 x 52)	2			
3	Valve + SUP stop valve (Top) + Individual SUP (Middle, Bottom) + Individual EXH (Middle, Bottom)	① AXT632-17-14 (M3 x 112)	3		For manifold
		② AXT632-17-13 (M3 x 77)	2		
	Valve + Double check spacer with residual pressure exhaust (Top) + Individual SUP (Middle, Bottom) + Individual EXH (Middle, Bottom)	① AXT632-17-16 (M3 x 137)	3		For manifold
		② AXT632-41-3 (M3 x 103) <i>Note 2)</i>	2		
	Valve + Spacer (Top): Interface regulator Spacer (Middle): "Individual SUP or Individual EXH"/"Restrictor" Spacer (Bottom): "Restrictor"/"Individual SUP or Individual EXH"	① AXT632-17-16 (M3 x 137)	3		For manifold The individual EXH and restrictor can be mounted on the top.
		② AXT632-41-3 (M3 x 103)	2		
Valve + Double check spacer with residual pressure exhaust (Top) + SUP stop valve (Middle) + Individual SUP (EXH) (Bottom)	① AXT632-17-16 (M3 x 137)	3	For manifold		
	② AXT632-41-3 (M3 x 103) <i>Note 2)</i>	2			
Valve + Interface regulator (TOP) + Double check spacer with residual pressure exhaust (Middle) + Individual SUP (EXH) (Bottom)	① AXT632-17-20 (M3 x 162)	3	For manifold available as special order		
	② AXT632-41-5 (M3 x 128)	2			

Note 1) When the SUP stop valve and individual SUP are mounted, the stop valve is mounted on the top of the individual SUP.

Note 2) Proper tightening torque: 0.5 to 0.7 N·m

Exploded View
of Manifold

Construction

Semi-standard
Specifications

Manifold
Options

VQ5000

Exploded View
of Manifold

Construction

Manifold with
Control Unit

Semi-standard
Specifications

Manifold
Options

VQ4000

Base Mounted

Plug-in/Plug Lead: Single Unit

Series VQ5000

Model

Series	Configuration	Model	Port size	Flow-rate characteristics								Response time [ms]		Weight [kg]	
				1 → 4/2 (P → A/B)				4/2 → 5/3 (A/B → EA/EB)				Standard: 0.95 W	Low wattage type: 0.4 W		
				C [dm ³ /(s·bar)]	b	Cv	Q [l/min (ANR)] Note 5)	C [dm ³ /(s·bar)]	b	Cv	Q [l/min (ANR)] Note 5)				
VQ5000	2-position	Single	Metal seal	VQ510	12	0.14	2.9	2182	14	0.18	3.4	3316	35	38	0.59 (0.67)
			Rubber seal	VQ511	16	0.33	4.4	4148	17	0.31	4.7	4350	40	43	0.58 (0.66)
		Double	Metal seal	VQ520	12	0.14	2.9	2782	14	0.18	3.4	3316	20	23	0.62 (0.70)
			Rubber seal	VQ521	16	0.33	4.4	4148	17	0.31	4.7	4350	25	28	0.60 (0.68)
	3-position	Closed centre	Metal seal	VQ530	11	0.24	2.6	2696	11	0.23	2.8	2681	50	53	0.65 (0.73)
			Rubber seal	VQ531	12	0.33	3.4	3111	13	0.37	3.7	3462	60	63	0.58 (0.66)
		Exhaust centre	Metal seal	VQ540	12	0.13	2.9	2767	14	0.18	3.4	3316	50	53	0.65 (0.73)
			Rubber seal	VQ541	14	0.39	3.9	3781	16	0.35	4.5	4203	60	63	0.58 (0.66)
		Pressure centre	Metal seal	VQ550	12	0.23	2.9	2924	13	0.24	3.3	3187	50	53	0.65 (0.73)
			Rubber seal	VQ551	13	0.32	3.4	3091	14	0.40	3.9	3808	60	63	0.58 (0.66)
		Double check	Metal seal	VQ560	8.0	—	—	1731	8.5	—	—	1839	62	65	1.17 (1.25)
			Rubber seal	VQ561	8.3	—	—	1796	9.0	—	—	1947	75	78	1.10 (1.18)

Note 1) Value for valve on sub-plate.

Note 2) Cylinder port 1/2: Value for valve on sub-plate.

Note 3) Based on JIS B 8375-1981. (Supply pressure: 0.5 MPa, with indicator light and surge voltage suppressor, clean air. This will change depending on pressure and air quality.) The value when ON for the double type.

Note 4) Values inside () indicate the weight of plug lead units.

Table: Without sub-plate, With sub-plate; Add 0.65 kg for plug-in type, 0.55 kg for plug lead type.

Note 5) These values have been calculated according to ISO 6358 and indicate the flow rate under standard conditions with an inlet pressure of 0.6 MPa (relative pressure) and a pressure drop of 0.1 MPa.

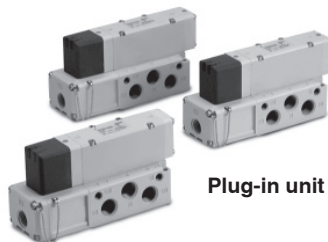

Plug-in unit

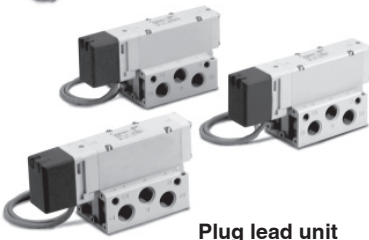

Plug lead unit

Symbol

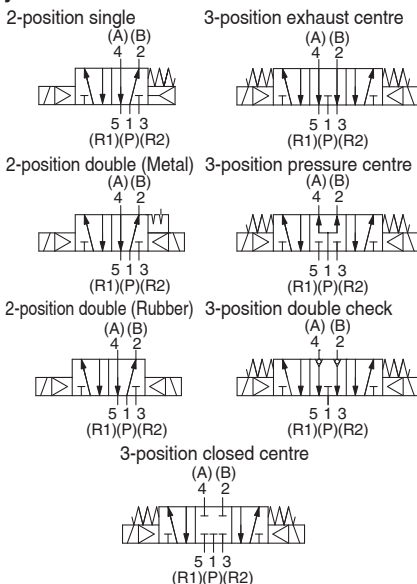

Standard Specifications

Valve specifications	Valve construction		Metal seal	Rubber seal
	Fluid		Air	
	Max. operating pressure		1.0 MPa	
	Min. operating pressure	Single	0.10 MPa	0.20 MPa
		Double	0.10 MPa	0.15 MPa
		3-position	0.15 MPa	0.20 MPa
	Ambient and fluid temperature		-10 to 50 °C Note 1)	
	Lubrication		Not required	
	Manual override		Push type/Locking type (Tool required)	
	Impact/Vibration resistance		150/30 m/s ² Note 2)	
Enclosure		Dust-tight (IP65 compatible) Note 3)		
Electrical specifications	Coil rated voltage		12, 24 VDC, 100, 110, 200, 220 VAC (50/60 Hz)	
	Allowable voltage fluctuation		±10 % of rated voltage	
	Coil insulation type		Class B or equivalent	
	Power consumption [W]	DC	Standard	0.95
		Low wattage type		0.4

Note 1) Use dry air to prevent condensation when operating at low temperatures.

Note 2) Impact resistance: No malfunction occurred when it is tested with a drop tester in the axial direction and at the right angles to the main valve and armature in both energised and de-energised states every once for each condition. (Values at the initial period)

Vibration resistance: No malfunction occurred in a one-sweep test between 45 and 2000 Hz. Test was performed at both energised and de-energised states in the axial direction and at the right angles to the main valve and armature. (Values at the initial period)

Note 3) Available only with T, L, S and C.



How to Order Valves (Single Unit)

Body

0: Plug-in sub-plate

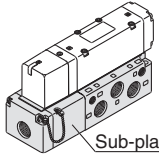

Sub-plate

Port size

—	Without sub-plate (For manifold)
04	1/2

Thread type

—	Rc
F	G
N	NPT
T	NPTF

Enclosure

—	Dust-protected
W	Dust-tight/Water-jet-proof (IP65)

Manual override

—	Non-locking push type (Tool required)
B	Locking type (Tool required)
C	Locking type (Manual)

Light/Surge voltage suppressor

—	Yes
E	Without light, with surge voltage suppressor

Electrical entry

G	Lead wire length 0.6 m
H	Lead wire length 1.5 m

Plug-in

Plug lead

VQ5 1 0 0 - 5

VQ5 2 5 1 - 5 G

Type of actuation

1	2-position single (A)(B) 4 2 (R1)(P)(R2)
2	2-position double (A)(B) 4 2 (R1)(P)(R2)
3	3-position closed centre (A)(B) 4 2 (R1)(P)(R2)
4	3-position exhaust centre (A)(B) 4 2 (R1)(P)(R2)
5	3-position pressure centre (A)(B) 4 2 (R1)(P)(R2)
6	3-position double check (A)(B) 4 2 (R1)(P)(R2)

Note) For details about double check type, refer to page 79.

Porting specifications

—	Side ported
B	Bottom ported

Coil voltage

5	24 V DC
6	12 V DC

Body

5: Plug lead sub-plate

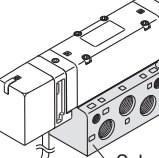

Sub-plate

Seal

0	Metal seal
1	Rubber seal

Function

— Note 1)	Standard (0.95 W)
Y	Low wattage type (0.4 W)
R Note 2)	External pilot

Note 1) When the unit is energised continuously, refer to "Specific Product Precautions 1" on page 88.
 Note 2) For details about external pilot specifications, refer to page 82. Combination of external pilot and perfect interface is not possible.
 Note 3) When multiple symbols are specified, indicate them alphabetically.

How to Order Sub-plates



VQ5000 - P - 04 - Q

Electrical entry

P	Plug-in conduit terminal
S	Plug lead

Thread type

—	Rc
F	G
N	NPT
T	NPTF

Port size

04	1/2
----	-----

Enclosure

—	Dust-protected
W Note)	Dust-tight/Water-jet-proof

Note) Not required for plug lead type.

Porting specifications

—	Side ported
B	Bottom ported

Replacement of pilot valve assembly (Voltage)

Refer to pages 83 and 84 for pilot valve assembly part numbers.
 Refer to page 89 for replacement method.

VQ4000
 Manifold Options
 Semi-standard Specifications
 Manifold with Control Unit
 Construction
 Exploded View of Manifold
 VQ5000
 Manifold Options
 Semi-standard Specifications
 Construction
 Exploded View of Manifold

Series VQ5000

Dimensions: Plug-in Type

Conduit terminal

2-position single: VQ510⁰

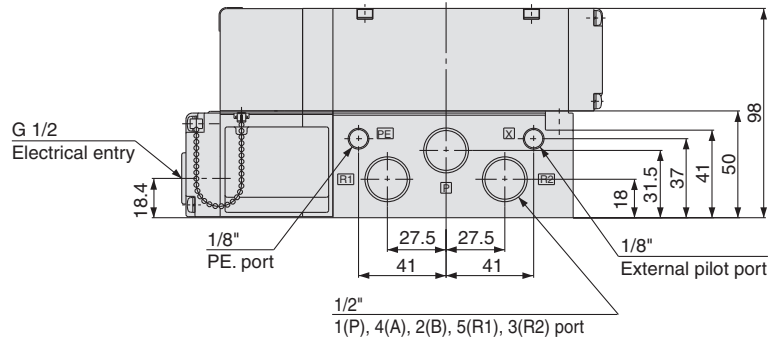
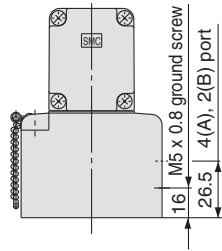

Bottom ported drawing

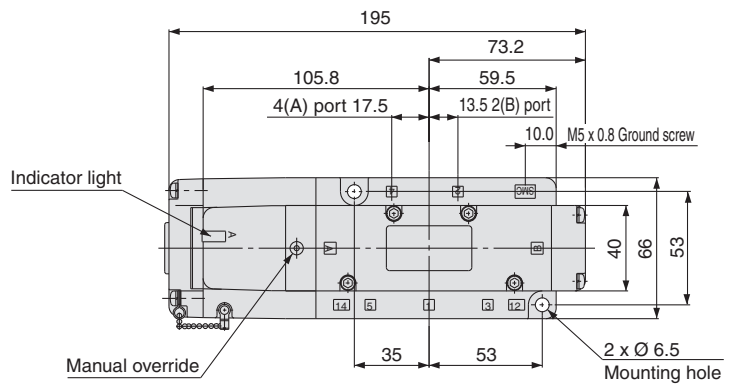
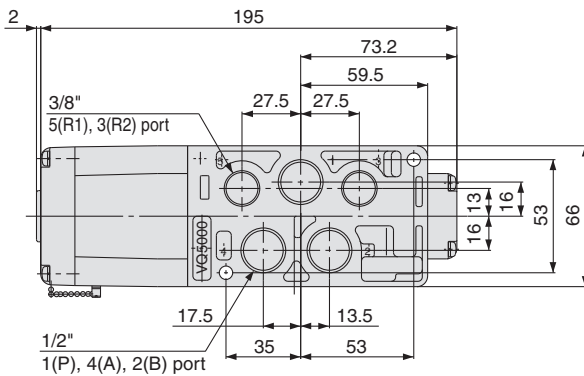

2-position double: VQ520⁰

3-position closed centre: VQ530⁰

3-position exhaust centre: VQ540⁰

3-position pressure centre: VQ550⁰

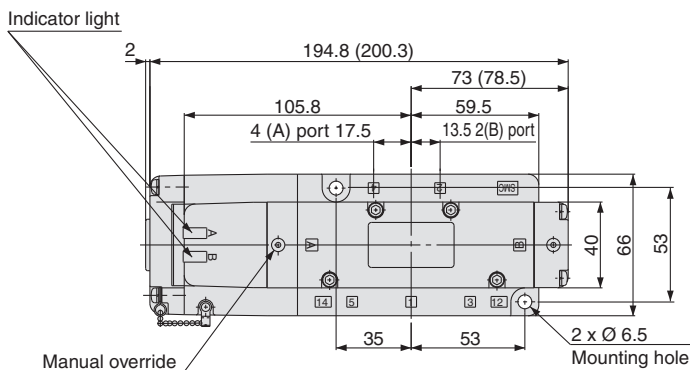
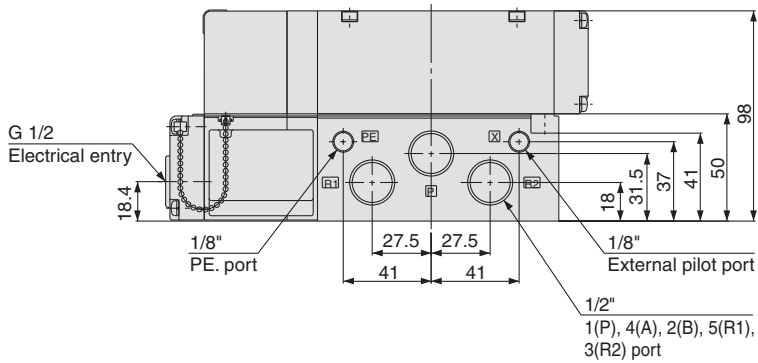

Numbers inside () are for metal seal 3-position type.

3-position double check: VQ560⁰

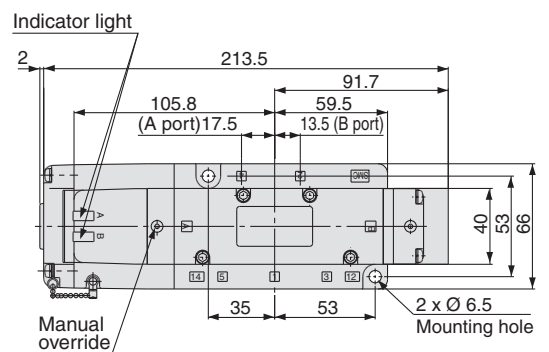
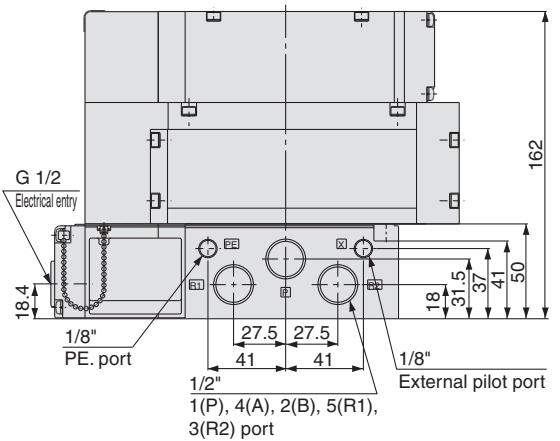

Dimensions: Plug Lead Type

Grommet

2-position single: VQ515⁰₁-□^G_H

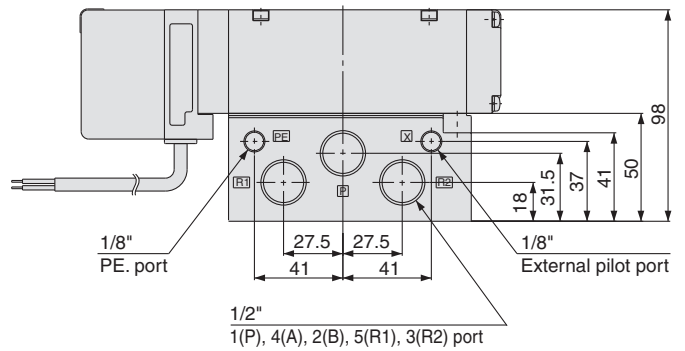
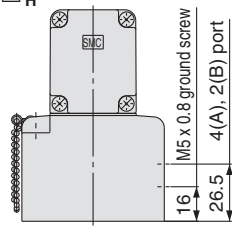

Bottom ported drawing

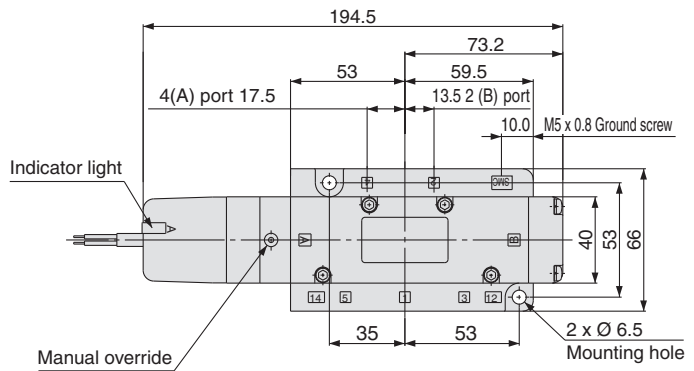
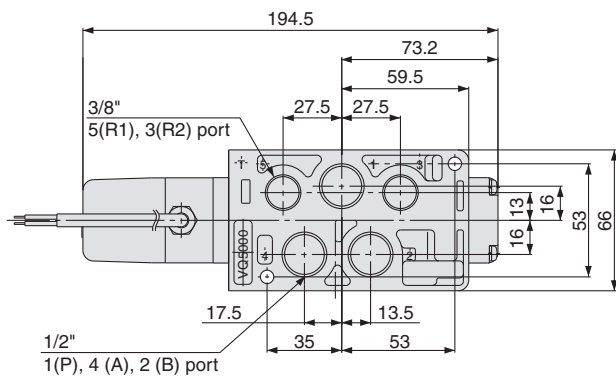

2-position double: VQ525⁰₁-□^G_H
 3-position closed centre: VQ535⁰₁-□^G_H
 3-position exhaust centre: VQ545⁰₁-□^G_H
 3-position pressure centre: VQ555⁰₁-□^G_H

3-position double check: VQ565⁰₁-□^G_H

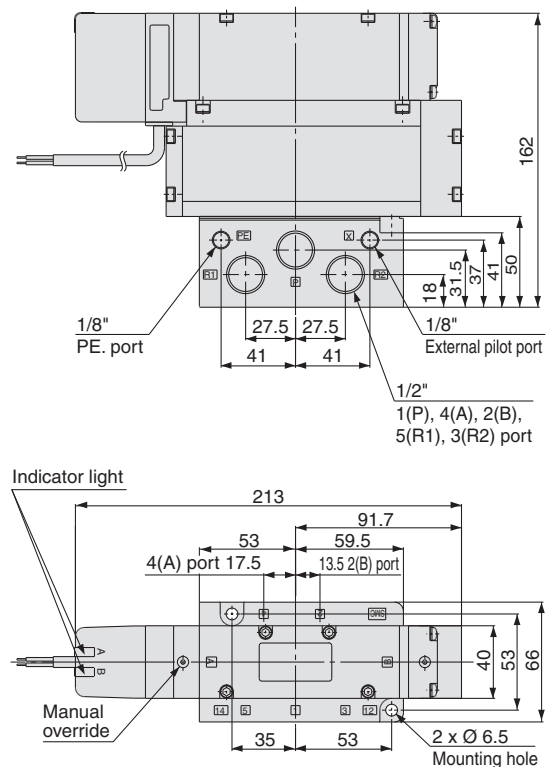
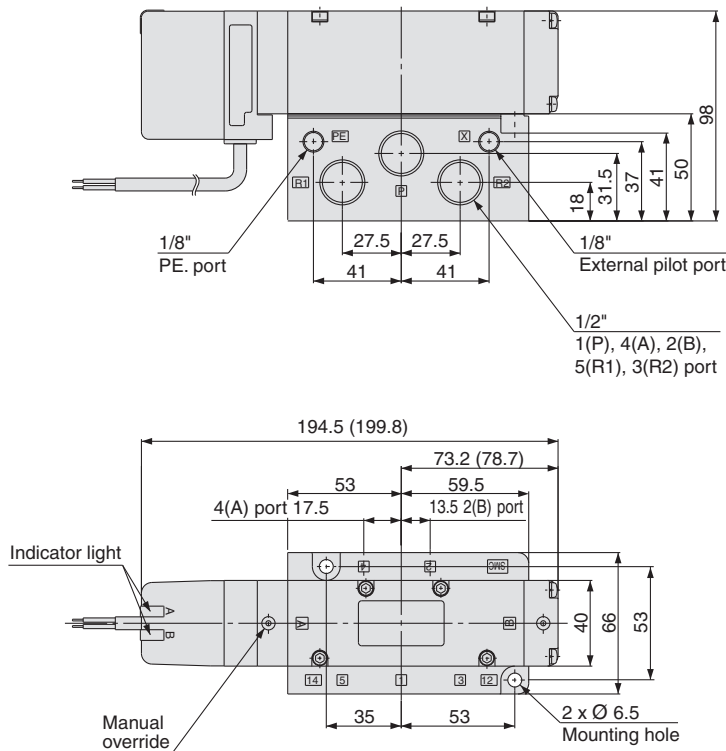

Numbers inside () are for metal seal 3-position type.

Base Mounted

Plug-in Unit

Series VQ5000



How to Order Manifold

VV5Q 5 1 - 08 03 [] FU1 - [] - Q

Series

5	VQ5000
---	--------

Manifold

1	Plug-in unit
---	--------------

Station

01	1 station
⋮	⋮
⋮	⋮

Minimum number of stations depends on the kit.
(Refer to the table below.)

Cylinder port

03	3/8
04	1/2
B	Bottom ported 1/2
CM	Mixed (Note)

Note) In case of mixed specification, indicate on the manifold specification sheet.

Thread type

—	Rc
F	G
N	NPT
T	NPTF

Option

Symbol	Option
—	None
CD1 (Note 2)	Exhaust cleaner for Rc 1: D side exhaust
CD2 (Note 2)	Exhaust cleaner for Rc 1 1/2: D side exhaust
CU1 (Note 2)	Exhaust cleaner for Rc 1: U side exhaust
CU2 (Note 2)	Exhaust cleaner for Rc 1 1/2: U side exhaust
K (Note 4)	Special wiring specifications (Except double wiring)
N	Name plate (T kit only)
SB (Note 2,3)	Direct exhaust with silencer box: Exhaust from both D and U sides
SD (Note 2)	Direct exhaust with silencer box: D side exhaust
SU (Note 2)	Direct exhaust with silencer box: U side exhaust
W	IP65 enclosure (Except F and T1 kits)

Note 1) When multiple symbols are specified, indicate them by letter in the order that they appear in the table, starting from the top. Example) -CU1K

Note 2) Combination of [C] and [S] is not possible. Also, exhaust cleaner is not attached. Please order it separately.

Note 3) Available only with F, L and T1 kits.

Note 4) Specify the wiring specifications on the manifold specification sheet. (Except L kit)

Kit/Electrical entry/Cable length

F Kit (D-sub connector)		L Kit (Lead wire cable)																																					
<table border="1"> <tr> <th colspan="2">Connector entry direction</th> <th rowspan="2"></th> <th rowspan="2">1 to 12 stations</th> </tr> <tr> <th>D side</th> <th>U side</th> </tr> <tr> <td>F Kit</td> <td>U0</td> <td>Without cable</td> <td rowspan="3"></td> </tr> <tr> <td>D1</td> <td>U1</td> <td>Cable length 1.5 m</td> </tr> <tr> <td>D2</td> <td>U2</td> <td>Cable length 3 m</td> </tr> <tr> <td>D3</td> <td>U3</td> <td>Cable length 5 m</td> <td></td> </tr> </table>		Connector entry direction			1 to 12 stations	D side	U side	F Kit	U0	Without cable		D1	U1	Cable length 1.5 m	D2	U2	Cable length 3 m	D3	U3	Cable length 5 m		<table border="1"> <tr> <th colspan="2">Connector entry direction</th> <th rowspan="2"></th> <th rowspan="2">1 to 12 stations</th> </tr> <tr> <th>D side</th> <th>U side</th> </tr> <tr> <td>L Kit</td> <td>U0</td> <td>Cable length 0.6 m</td> <td rowspan="3">IP65 compatible</td> </tr> <tr> <td>D1</td> <td>U1</td> <td>Cable length 1.5 m</td> </tr> <tr> <td>D2</td> <td>U2</td> <td>Cable length 3 m</td> </tr> </table>		Connector entry direction			1 to 12 stations	D side	U side	L Kit	U0	Cable length 0.6 m	IP65 compatible	D1	U1	Cable length 1.5 m	D2	U2	Cable length 3 m
Connector entry direction			1 to 12 stations																																				
D side	U side																																						
F Kit	U0	Without cable																																					
D1	U1	Cable length 1.5 m																																					
D2	U2	Cable length 3 m																																					
D3	U3	Cable length 5 m																																					
Connector entry direction			1 to 12 stations																																				
D side	U side																																						
L Kit	U0	Cable length 0.6 m	IP65 compatible																																				
D1	U1	Cable length 1.5 m																																					
D2	U2	Cable length 3 m																																					
T Kit (Terminal block box kit)		S Kit (Serial transmission unit)																																					
<table border="1"> <tr> <th colspan="2">Box mounting position</th> <th rowspan="2"></th> <th rowspan="2">2 to 12 stations (Note)</th> </tr> <tr> <th>D side</th> <th>U side</th> </tr> <tr> <td>TD</td> <td>TU</td> <td>Terminal block box</td> <td></td> </tr> </table>		Box mounting position			2 to 12 stations (Note)	D side	U side	TD	TU	Terminal block box		<p>The valve voltage is 24 VDC and it is equipped with light/surge voltage suppressor.</p>																											
Box mounting position			2 to 12 stations (Note)																																				
D side	U side																																						
TD	TU	Terminal block box																																					
T1 Kit (Individual terminal block kit)		SU Kit (Serial transmission unit)																																					
<table border="1"> <tr> <th colspan="2">Unit mounting position</th> <th rowspan="2"></th> <th rowspan="2">2 to 12 stations (Note)</th> </tr> <tr> <th>D side</th> <th>U side</th> </tr> <tr> <td>T1 Kit</td> <td>U0</td> <td>Without SI Unit</td> <td rowspan="5"></td> </tr> <tr> <td></td> <td>Q</td> <td>DeviceNet</td> </tr> <tr> <td></td> <td>R1</td> <td>OMRON Corp.: CompoBus/S (16 output points)</td> </tr> <tr> <td></td> <td>R2</td> <td>OMRON Corp.: CompoBus/S (8 output points)</td> </tr> <tr> <td></td> <td>V</td> <td>CC-LINK System</td> </tr> </table>		Unit mounting position			2 to 12 stations (Note)	D side	U side	T1 Kit	U0	Without SI Unit			Q	DeviceNet		R1	OMRON Corp.: CompoBus/S (16 output points)		R2	OMRON Corp.: CompoBus/S (8 output points)		V	CC-LINK System	<p>IP65 compatible</p>															
Unit mounting position			2 to 12 stations (Note)																																				
D side	U side																																						
T1 Kit	U0	Without SI Unit																																					
	Q	DeviceNet																																					
	R1	OMRON Corp.: CompoBus/S (16 output points)																																					
	R2	OMRON Corp.: CompoBus/S (8 output points)																																					
	V	CC-LINK System																																					

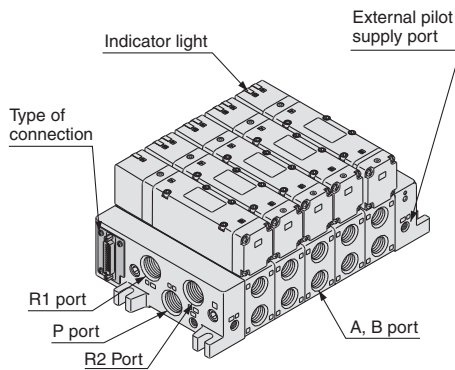

Note) Figure shows VV5Q51-0504FD0.

S, T kit

When mounting a terminal block box or serial unit, be aware that they take up 2 stations of the manifold. In the drawing below, you can see that of the 8 manifold stations, 6 stations are available to be used for built-in valves, options, etc.

VV5Q51-0704TU

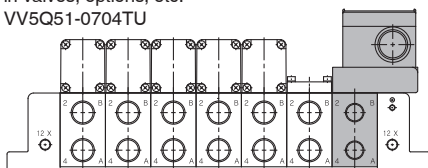

Note) For the T kit and S kit, one station is required to mount the terminal block box or SI Unit, so the minimum number of stations is 2 stations.

Manifold Specifications

Series	Base model	Type of connection	Porting specifications		Maximum applicable stations	Applicable valve	Weight [kg] (Formula)	
			4(A), 2(B) port location	Port size				
				1(P), 5(R1), 3(R2)				4(A), 2(B)
VQ5000	VV5Q51-□□□	<ul style="list-style-type: none"> ■ F kit—D-sub connector ■ T kit—Terminal block box ■ T1 kit—Individual terminal block kit ■ L kit—Lead wire ■ S kit—Serial transmission 	Side	3/4 Option { Direct exhaust with silencer box }	3/8 1/2	F, L, T1 kits 12 stations T kit 12 stations S kit 12 stations	VQ5□00 VQ5□01	F, L kit: 0.62n + 1.4 S, T kit: 0.62(n-1) + 2.6 • Not including valve weight.
			Bottom					

n: Stations

Flow-rate Characteristics at the Number of Manifold Stations (Operated individually)

Model	Passage/Stations	Station 1	Station 5	Station 10	
2-position metal seal VQ5 ₂ ⁰⁰	1 → 4/2 (P → A/B)	C [dm ³ /(s-bar)]	11	11	11
		b	0.24	0.24	0.24
		Cv	2.7	2.7	2.7
		Q [l/min (ANR)] note 2)	2696	2696	2696
	4/2 → 5/3 (A/B → EA/EB)	C [dm ³ /(s-bar)]	12	12	12
		b	0.14	0.14	0.14
Cv		2.9	2.9	2.9	
Q [l/min (ANR)] note 2)		2782	2782	2782	
2-position rubber seal VQ5 ₂ ⁰¹	1 → 4/2 (P → A/B)	C [dm ³ /(s-bar)]	12	12	12
		b	0.33	0.33	0.33
		Cv	3.4	3.4	3.4
		Q [l/min (ANR)] note 2)	3111	3111	3111
	4/2 → 5/3 (A/B → EA/EB)	C [dm ³ /(s-bar)]	16	16	16
		b	0.33	0.33	0.33
		Cv	4.4	4.4	4.4
		Q [l/min (ANR)] note 2)	4148	4148	4148

Note 1) For port size 1/2 Note 2) These values have been calculated according to ISO 6358 and indicate the flow rate under standard conditions with an inlet pressure of 0.6 MPa (relative pressure) and a pressure drop of 0.1 MPa.

Manifold Options

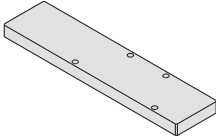
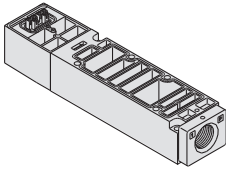
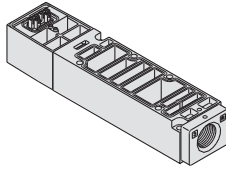
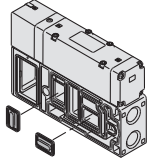
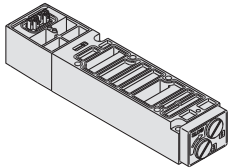
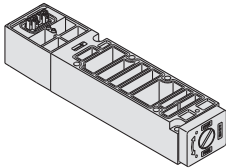
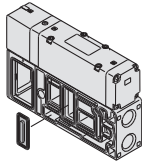
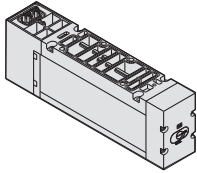
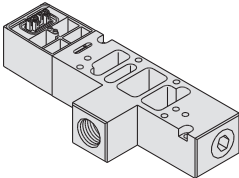
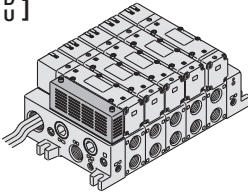
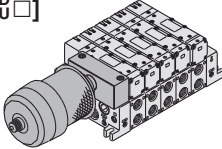
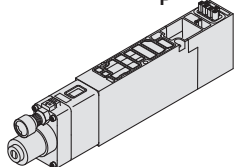
Blanking plate assembly VVQ5000-10A-1 	Individual SUP spacer VVQ5000-P-1- ⁰³ / ₀₄ 	Individual EXH spacer VVQ5000-R-1- ⁰³ / ₀₄ 	EXH block plate VVQ5000-16A-2 
Restrictor spacer VVQ5000-20A-1 	SUP stop valve spacer VVQ5000-37A-1 	SUP block plate VVQ5000-16A-1 	Double check spacer with residual pressure exhaust VVQ5000-25A-1 
Release valve spacer: For D side mounting VVQ5000-24A-1D 	Direct exhaust with silencer box [-S ₀ ^D] 	Manifold mounted exhaust cleaner [-C ₀ ^D □] 	Interface regulator (P, A, B port regulation) ARBQ5000-00- ^A / _P -1 

• Refer to pages 77 to 81 for detailed dimensions of each option.
• For replacement parts, refer to page 86.

Series VQ5000

F Kit (D-sub connector kit)

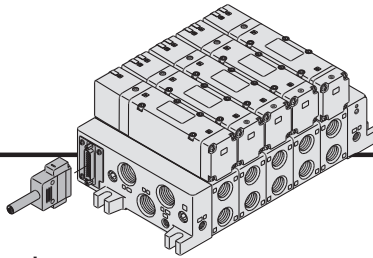

- Simplification and labour savings for wiring work can be achieved by using a D-sub connector for the electrical connection.
- Using connector for flat ribbon cable (25P) conforming to MIL standard permits the use of connectors put on the market and gives a wide interchangeability.
- Connector entry can be selected on either the U side or the D side according to the mounting orientation.
- Maximum stations are 12.

Manifold Specifications

Series	Porting specifications			Applicable stations
	4(A), 2(B) port location	Port size		
VQ5000	Side	3/4	3/8	Max. 12 stations
	Bottom		1/2	

D-Sub Connector Kit (25 pins)

Cable assembly ●

015
AXT100-DS25-030
050

(D-sub connector cable assemblies can be ordered with manifolds.)
Refer to How to Order Manifold.

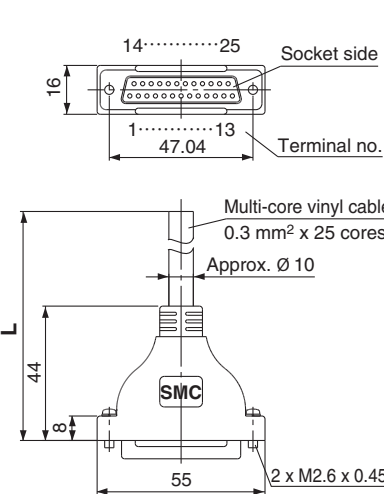

D-sub Connector Cable Assembly

Cable length(L)	Assembly part no.	Note
1.5 m	AXT100-DS25-015	Cable
3 m	AXT100-DS25-030	0.3 mm ²
5 m	AXT100-DS25-050	x 25 cores

* For other commercial connectors, use a 25-pin type female connector conforming to MIL-C-24308.
* Cannot be used for transfer wiring.

Connector Manufacturers Example

- Fujitsu, Ltd.
- Japan Aviation Electronics Industry, Ltd.
- J.S.T. Mfg. Co., Ltd.
- Hirose Electric Co., Ltd.

Electric Characteristics

Item	Characteristics
Conductor resistance Ω/km, 20 °C	65 or less
Voltage limit V AC, 1 min.	1000
Insulation resistance MΩ/km, 20 °C	5 or more

Note) The minimum bending radius for D-sub connector cables is 20 mm.

D-sub Connector Cable Assembly Terminal No.

Terminal no.	Lead wire colour	Dot marking
1	Black	None
2	Brown	None
3	Red	None
4	Orange	None
5	Yellow	None
6	Pink	None
7	Blue	None
8	Purple	White
9	Grey	Black
10	White	Black
11	White	Red
12	Yellow	Red
13	Orange	Red
14	Yellow	Black
15	Pink	Black
16	Blue	White
17	Purple	None
18	Grey	None
19	Orange	Black
20	Red	White
21	Brown	White
22	Pink	Red
23	Grey	Red
24	Black	White
25	White	None

Note) Lengths other than the above are also available. Please contact SMC for details.

How to Order Manifold



VV5Q 5 1 - 08 03 [] F U 1 - [] - Q

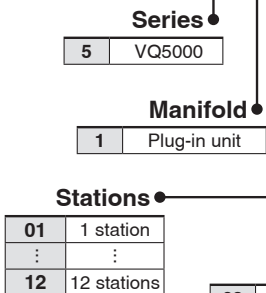

Cylinder port

03	3/8
04	1/2
B	Bottom ported 1/2
CM	Mixed

Thread type

—	Rc
F	G
N	NPT
T	NPTF

Connector entry direction

D	D side entry
U	U side entry

Cable (Length)

0	Without cable
1	Cable length 1.5 m
2	Cable length 3 m
3	Cable length 5 m

Option

Symbol	Option
—	None
CD1	Exhaust cleaner for Rc 1: D side exhaust
CD2	Exhaust cleaner for Rc 1 1/2: D side exhaust
CU1	Exhaust cleaner for Rc 1: U side exhaust
CU2	Exhaust cleaner for Rc 1 1/2: U side exhaust
K	Special wiring specifications (Except double wiring)
SB	Direct exhaust with silencer box: For mounting on both D and U sides
SD	Direct exhaust with silencer box: D side exhaust
SU	Direct exhaust with silencer box: U side exhaust

Note 1) When multiple symbols are specified, indicate them alphabetically. Example) -CD1K.
Note 2) Combination of [C_D□] and [S_D^U] is not possible.
Note 3) Specify the wiring specifications on the manifold specification sheet.

● **Electrical wiring specifications**

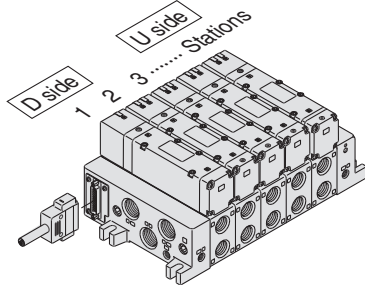

Stations are counted starting from the first station on the D side.

D-sub connector

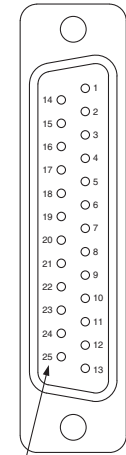

Connector terminal no.

Double wiring (connected to SOL. A and SOL. B) is adopted for the internal wiring of each station, regardless of valve and option types. Mixed single and double wiring is available as a semi-standard specification. For details, refer to below.

Standard wiring

Terminal no.	Wiring
1	SOL.A
14	SOL.B
2	SOL.A
15	SOL.B
3	SOL.A
16	SOL.B
4	SOL.A
17	SOL.B
5	SOL.A
18	SOL.B
6	SOL.A
19	SOL.B
7	SOL.A
20	SOL.B
8	SOL.A
21	SOL.B
9	SOL.A
22	SOL.B
10	SOL.A
23	SOL.B
11	SOL.A
24	SOL.B
12	SOL.A
25	SOL.B
13	COM.

D-sub connector assembly (AXT100-DS25-015-030-050) Wire colours

Terminal no.	Polarity	Lead wire colour	Dot marking
1	(-)	(+) Black	None
14	(-)	(+) Yellow	Black
2	(-)	(+) Brown	None
15	(-)	(+) Pink	Black
3	(-)	(+) Red	None
16	(-)	(+) Blue	White
4	(-)	(+) Orange	None
17	(-)	(+) Purple	None
5	(-)	(+) Yellow	None
18	(-)	(+) Grey	None
6	(-)	(+) Pink	None
19	(-)	(+) Orange	Black
7	(-)	(+) Blue	None
20	(-)	(+) Red	White
8	(-)	(+) Purple	White
21	(-)	(+) Brown	White
9	(-)	(+) Grey	Black
22	(-)	(+) Pink	Red
10	(-)	(+) White	Black
23	(-)	(+) Grey	Red
11	(-)	(+) White	Red
24	(-)	(+) Black	White
12	(-)	(+) Yellow	Red
25	(-)	(+) White	None
13	(+)	(-) Orange	Red

Positive common specifications Negative common specifications

Special Wiring Specifications

Double wiring (connected to SOL. A and SOL. B) is used for the internal wiring of each station regardless of valve and option types. Mixed single and double wiring is available as a semi-standard specification.

1. How to Order

Indicate option symbol "K" in the manifold part number and be sure to specify station positions for single or double wiring on the manifold specification sheet.

2. Wiring specifications

Connections begin with the A side solenoid of the first station being connected to terminal no. 1, and continue in the order indicated by the arrows in the drawing without skipping any terminals. However, the maximum number of stations is 12.

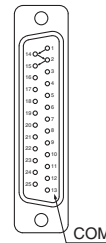

D-sub connector

How to Order Valves

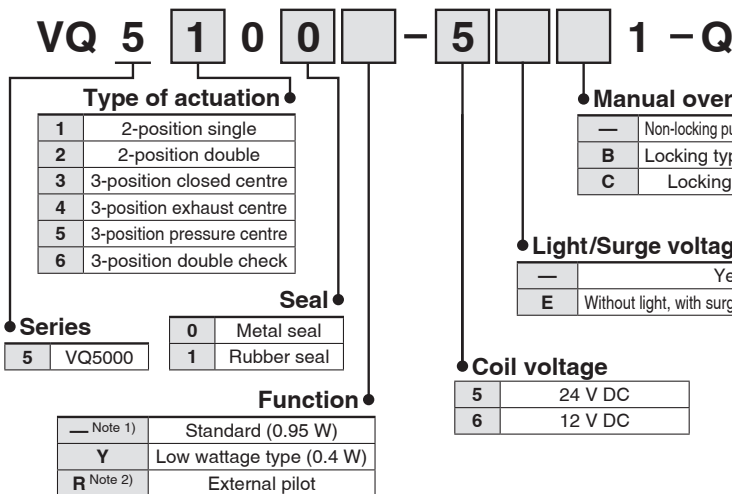

Note 1) When the unit is energised continuously, refer to "Specific Product Precautions 1" on page 88.
 Note 2) For details about external pilot specifications, refer to page 82. Combination of external pilot and perfect interface is not possible.
 Note 3) When multiple symbols are specified, indicate them alphabetically.

How to Order Manifold Assembly

Specify the part numbers for valves and options together beneath the manifold base part number.

<Example>

D-sub connector kit with cable (3 m)
VV5Q51-0503FD2[-Q]...1 set—Manifold base part no.
 *VQ5100-51[-Q]...2 sets—Valve part no. (Stations 1 and 2)
 *VQ5200-51[-Q]...2 sets—Valve part no. (Stations 3 and 4)
 *VQ5300-51[-Q]...1 set—Valve part no. (Station 5)

Prefix the asterisk to the part nos. of the valve etc.

Enter in order starting from the first station on the D side. When entry of part numbers becomes complicated, indicate in the manifold specification sheet.

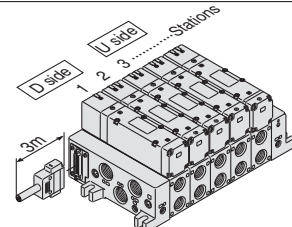

VQ4000
 Manifold Options
 Semi-standard Specifications
 Manifold with Control Unit
 Construction
 Exploded View of Manifold

VQ5000
 Manifold Options
 Semi-standard Specifications
 Construction
 Exploded View of Manifold

Series VQ5000

F Kit (D-sub connector kit)

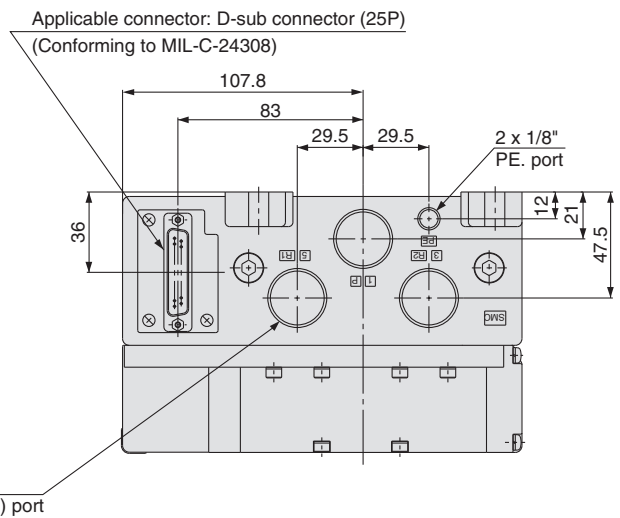
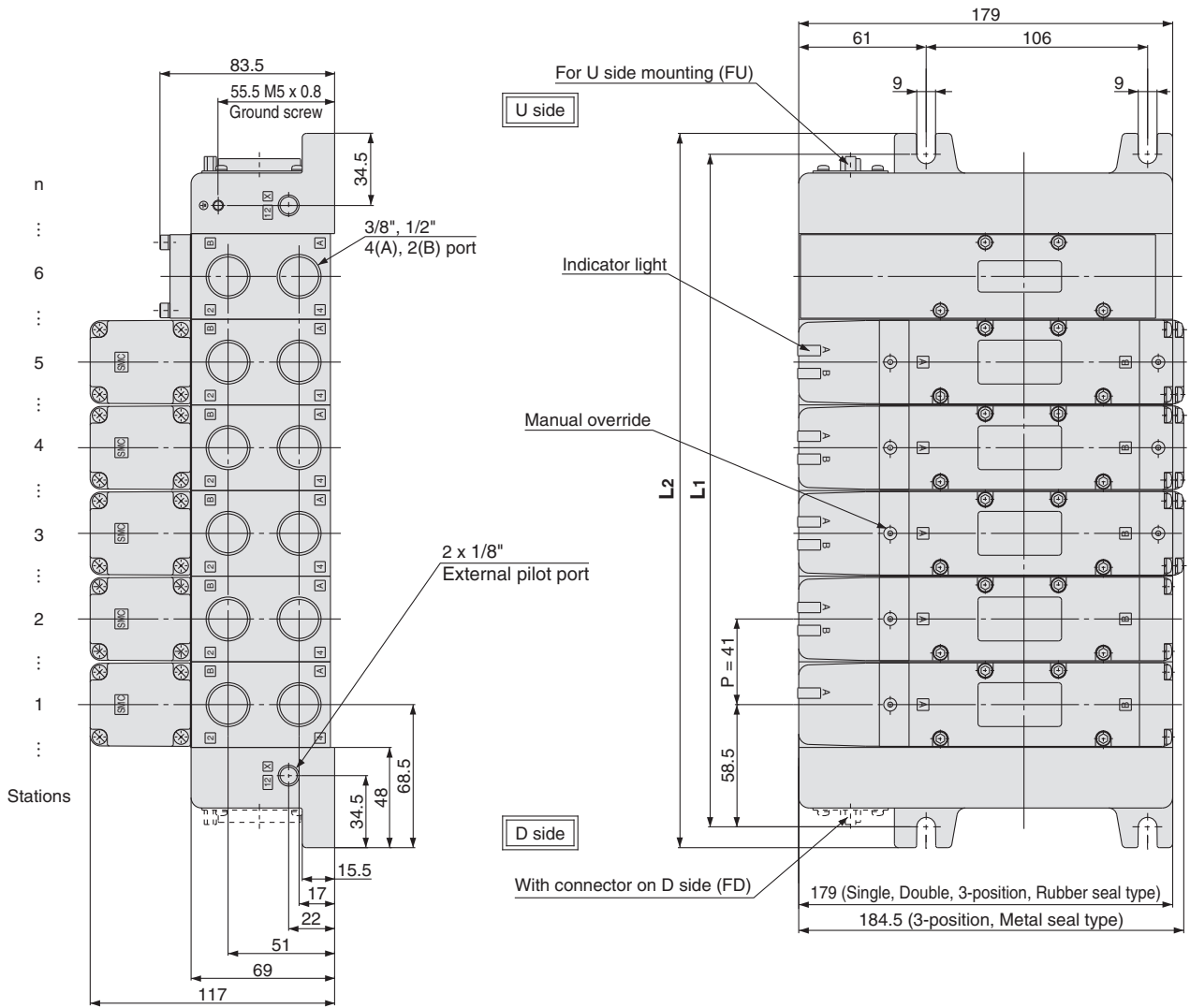

Bottom ported drawing

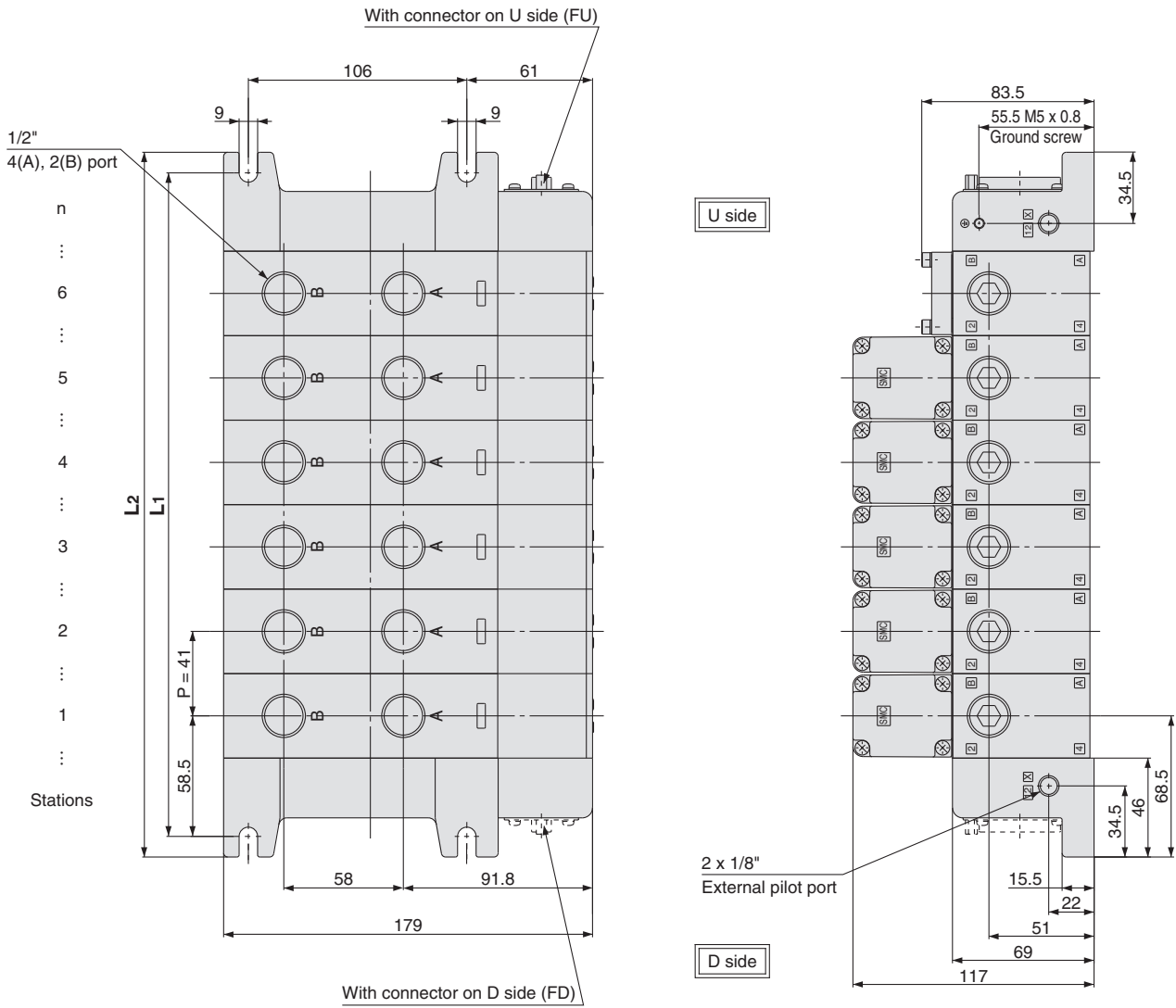

Dimensions

L \ n	1	2	3	4	5	6	7	8	9	10	11	12
L1	117	158	199	240	281	322	363	404	445	486	527	568
L2	137	178	219	260	301	342	383	424	465	506	547	588

Formula: L1 = 41n + 76, L2 = 41n + 96 n: Stations (Maximum 12 stations)

VQ4000

Manifold Options

Semi-standard Specifications

Manifold with Control Unit

Construction

Exploded View of Manifold

VQ5000

Manifold Options

Semi-standard Specifications

Construction

Exploded View of Manifold

Series VQ5000

T Kit (Terminal block box kit)

IP65 compliant

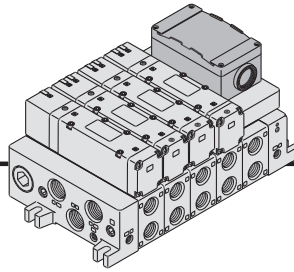

- Enclosure IP65 compliant
- This type has a small terminal block inside a junction box. The provision of a G3/4 electrical entry allows connection of conduit fittings.
- Maximum stations are 11. (12 stations as a semi-standard specification)
- 1 station is used for terminal block box mounting.

Manifold Specifications

Series	Porting specifications			Applicable stations
	4(A), 2(B) port location	Port size		
		1(P), 5(R1), 3(R2)	4(A), 2(B)	
VQ5000	Side	3/4	3/8	Max. 12 stations
	Bottom		1/2	

Terminal Block Connections

Step 1. How to remove terminal block cover

Loosen the 4 mounting screws (M4) and open the terminal block cover.

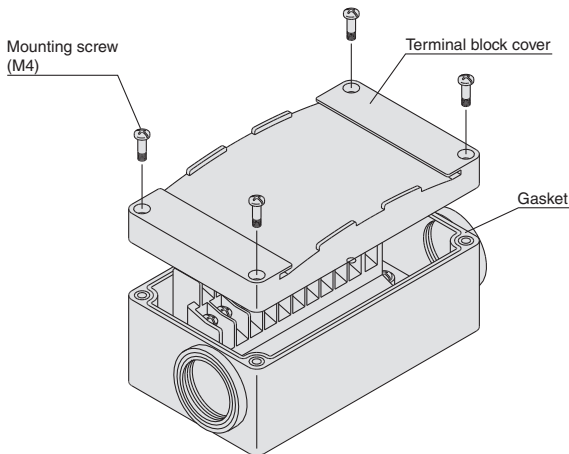

Step 2. The diagram on the right shows the terminal block wiring.

All stations are provided with double wiring regardless of the valves which are mounted.

Connect each wire to the power supply side, according to the markings provided inside the terminal block.

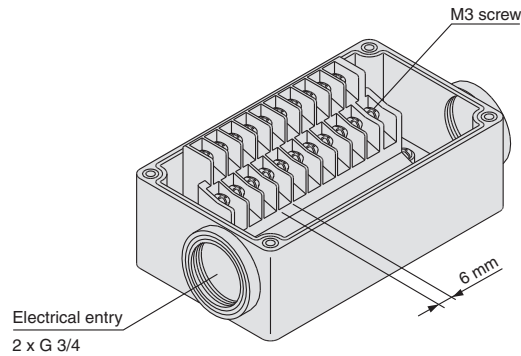

Step 3. How to attach the terminal block cover

Securely tighten the screws with the torque shown in the table below, after confirming that the gasket is installed correctly.

Proper tightening torque [N·m]
0.7 to 1.2

- Applicable terminal: 1.25-3S, 1.25Y-3, 1.25Y-3N, 1.25Y-3.5
- Name plate: VVQ5000-N-T
- Drip-proof plug assembly (for G 3/4): AXT100-B06A



How to Order Manifold

VV5Q 5 1 - 08 03 T - Q

Series
5 VQ5000

Manifold
1 Plug-in unit

Stations	
02	2 stations
⋮	⋮
12	12 stations

Note) One station is used for mounting the terminal block box. The number of stations is the number of manifold valves plus one station for the terminal block box. For 12 stations, specify the wiring specifications by means of the manifold specification sheet.

Cylinder port	
03	3/8
04	1/2
B	Bottom ported 1/2
CM	Mixed

Box mounting position
D D side mounting
U U side mounting

Thread type	
-	Rc
F	G
N	NPT
T	NPTF

Option

Symbol	Option
-	None
CD1 Note 2)	Exhaust cleaner for Rc 1: D side exhaust
CD2 Note 2)	Exhaust cleaner for Rc 1 1/2: D side exhaust
CU1 Note 2)	Exhaust cleaner for Rc 1: U side exhaust
CU2 Note 2)	Exhaust cleaner for Rc 1 1/2: U side exhaust
K Note 3)	Special wiring specifications (Except double wiring, 12 stations)
N	Name plate
SD Note 2)	Direct exhaust with silencer box: D side exhaust
SU Note 2)	Direct exhaust with silencer box: U side exhaust
W	IP65 enclosure

Note 1) When multiple symbols are specified, indicate them alphabetically.
Example) -CD1K

Note 2) Combination of [C₀] and [S₀] is not possible.

Note 3) Specify the wiring specifications on the manifold specification sheet.

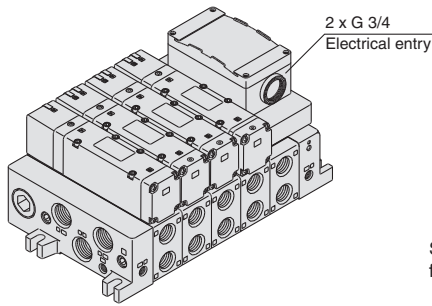

Stations are counted starting from the first station on the D side.

Electrical wiring specifications (IP65 available)

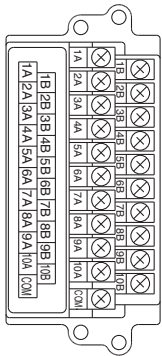

Double wiring (connected to SOL. A and SOL. B) is adopted for the internal wiring of each station, regardless of valve and option types. Mixed single and double wiring is available as a semi-standard specification.

Standard wiring

	Terminal no.	Polarity
1 station	SOL.A o1A	(-) (+)
	SOL.B o1B	(-) (+)
2 stations	SOL.A o2A	(-) (+)
	SOL.B o2B	(-) (+)
3 stations	SOL.A o3A	(-) (+)
	SOL.B o3B	(-) (+)
4 stations	SOL.A o4A	(-) (+)
	SOL.B o4B	(-) (+)
5 stations	SOL.A o5A	(-) (+)
	SOL.B o5B	(-) (+)
6 stations	SOL.A o6A	(-) (+)
	SOL.B o6B	(-) (+)
7 stations	SOL.A o7A	(-) (+)
	SOL.B o7B	(-) (+)
8 stations	SOL.A o8A	(-) (+)
	SOL.B o8B	(-) (+)
9 stations	SOL.A o9A	(-) (+)
	SOL.B o9B	(-) (+)
10 stations	SOL.A o10A	(-) (+)
	SOL.B o10B	(-) (+)
	SOL.A oCOM	(+) (-)

Positive Negative
common common

Special Wiring Specifications

Double wiring (connected to SOL. A and SOL. B) is used for the internal wiring of each station regardless of valve and option types. The optional specification permits mixture of single and double wiring. However, the maximum number of stations is 12.

1. How to Order

Indicate option symbol ("K") in the manifold part number and be sure to specify station positions for single or double wiring on the manifold specification sheet.

2. Wiring specifications

Connections begin with the A side solenoid of the first station being connected to terminal no. 1, and continue in the order indicated by the arrows in the drawing without skipping any terminals.



How to Order Valves



VQ 5 1 0 0 - 5 1 - Q

Type of actuation

1	2-position single
2	2-position double
3	3-position closed centre
4	3-position exhaust centre
5	3-position pressure centre
6	3-position double check

Seal

0	Metal seal
1	Rubber seal

Function

—	Standard (0.95 W)
Y	Low wattage type (0.4 W)
R	External pilot

Note 1) When the unit is energised continuously, refer to "Specific Product Precautions 1" on page 88.

Note 2) For details about external pilot specifications, refer to page 82. Combination of external pilot and perfect interface is not possible.

Note 3) When multiple symbols are specified, indicate them alphabetically.

Enclosure

—	Dust-protected
W	Dust-tight/ Water-jet-proof (IP65)

Manual override

—	Non-locking push type (Tool required)
B	Locking type (Tool required)
C	Locking type (Manual)

Light/Surge voltage suppressor

—	Yes
E	Without light, with surge voltage suppressor

Coil voltage

5	24 V DC
6	12 V DC

How to Order Manifold Assembly

Specify the part numbers for valves and options together beneath the manifold base part number.

<Example>

Terminal block box kit

VV5Q51-0603TU[-Q]-1 set—Manifold base part no.

*VQ5100-51[-Q].....2 sets—Valve part no. (Stations 1 and 2)

*VQ5200-51[-Q].....2 sets—Valve part no. (Stations 3 and 4)

*VQ5300-51[-Q].....1 set—Valve part no. (Station 5)

Prefix the asterisk to the part nos. of the valve etc.

Enter in order starting from the first station on the D side. When entry of part numbers becomes complicated, indicate in the manifold specification sheet.

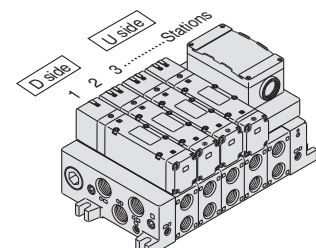

Series VQ5000

T Kit (Terminal block box kit)

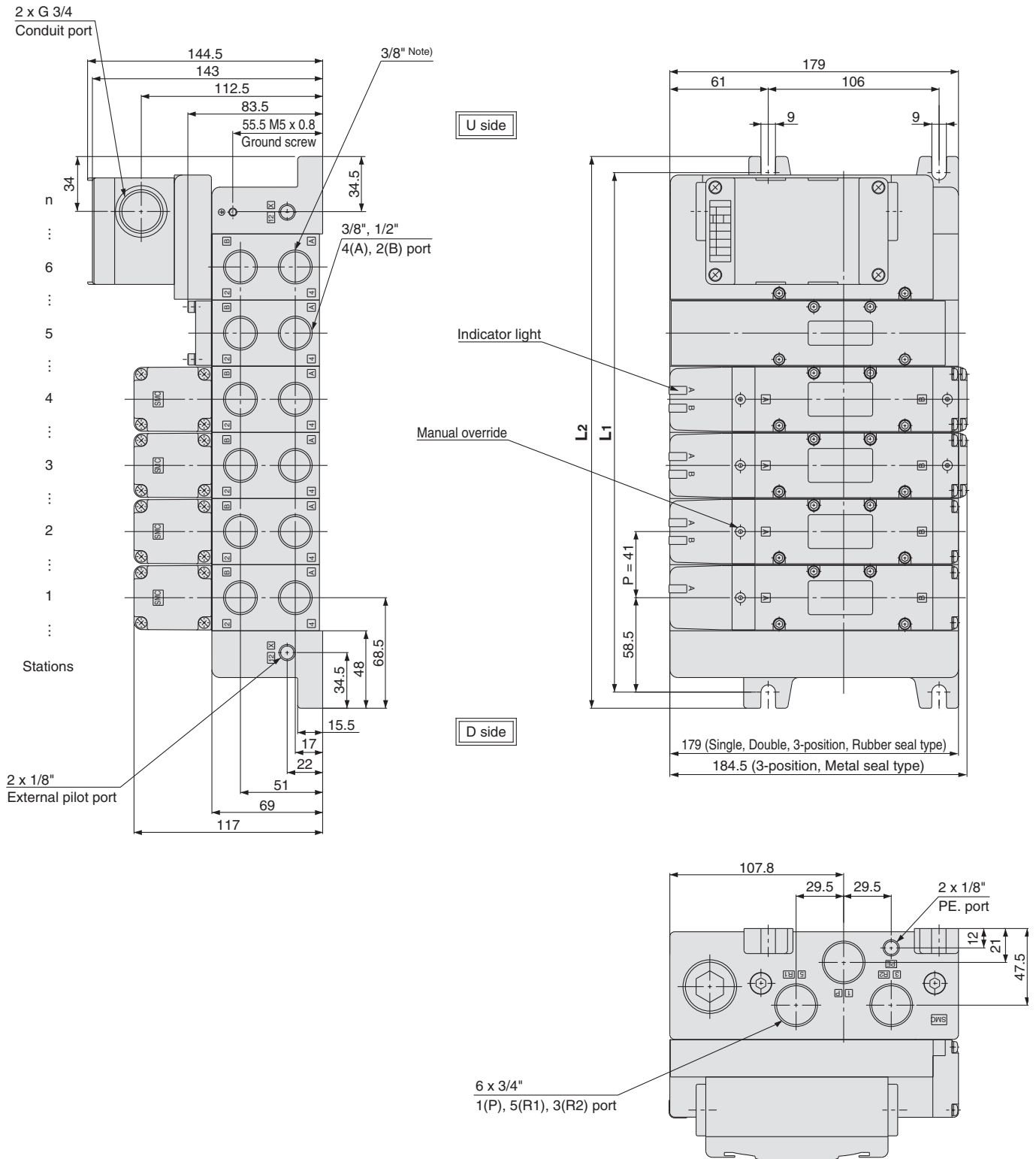

Note) 4(A) and 2(B) port at the bottom of the terminal block box are 3/8".

Bottom ported drawing

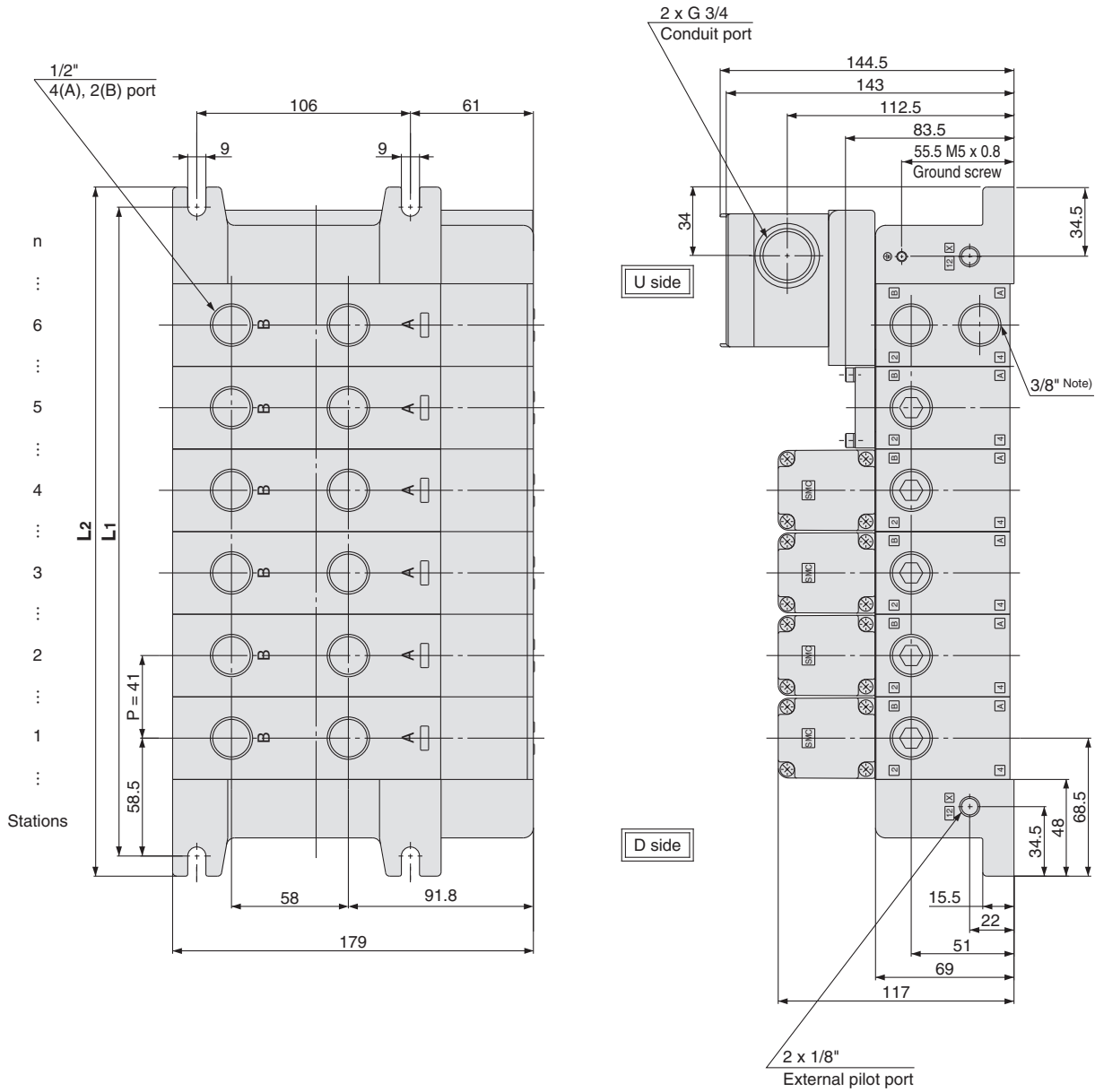

Note) 4(A) and 2(B) port at the bottom of the terminal block box are 3/8".

Dimensions

L	n	2	3	4	5	6	7	8	9	10	11	12
L1		158	199	240	281	322	363	404	445	486	527	568
L2		178	219	260	301	342	383	424	465	506	547	588

Formula: $L_1 = 41n + 76$, $L_2 = 41n + 96$

n: Stations (Maximum 12 stations)

* Including 1 station for mounting terminal box.

VQ4000

Manifold Options

Semi-standard Specifications

Manifold with Control Unit

Construction

Exploded View of Manifold

VQ5000

Manifold Options

Semi-standard Specifications

Construction

Exploded View of Manifold

Series VQ5000

T1 Kit (Individual terminal block kit)

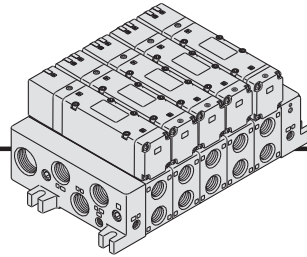

- When the junction cover on the manifold is opened, terminal box is installed in the manifold block. Lead wire from a solenoid is connected with the terminals on the terminal box in the bottom side. (The terminal box is connected with lead wire for both SOL. A and SOL. B and they correspond with the marking 1, 2, 3, 4 on the terminal box. Refer to how to connect with the terminal box.)
- Maximum stations are 12.

Manifold Specifications

Series	Porting specifications		Applicable stations
	4(A), 2(B) port location	Port size	
VQ5000	Side	3/4	Max. 12 stations
	Bottom	1/2	

Terminal Block Connections

Terminal block marking	1	3	2	4
VQ510 ₁ ⁰	A side +	A side -		
VQ520 ₁ ⁰	A side +	A side -	B side +	B side -
VQ540 ₁ ³ ₅ ⁰	A side +	A side -	B side +	B side -

- Compatible crimp terminals: 1.25-3S, 1.25Y-3, 1.25Y-3N, 1.25Y-3.5
- There is no polarity (+, -).

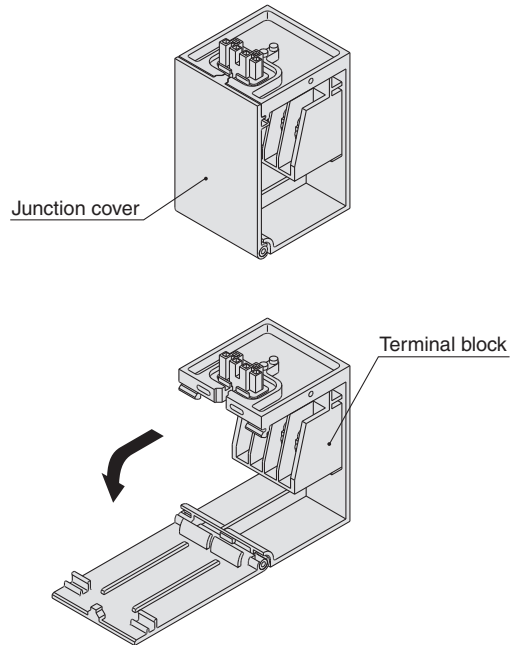
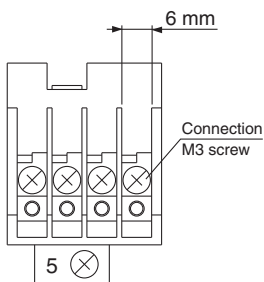
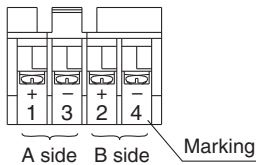

How to Order Manifold



VV5Q 5 1 - 08 03 T1 - Q

Series

5	VQ5000
---	--------

Manifold

1	Plug-in unit
---	--------------

Stations

01	1 station
⋮	⋮
12	12 stations

Thread type

—	Rc
F	G
N	NPT
T	NPTF

Cylinder port

03	3/8
04	1/2
B	Bottom ported 1/2
CM	Mixed

Option

Symbol	Option
—	None
CD1 ^{Note)}	Exhaust cleaner for Rc 1: D side exhaust
CD2 ^{Note)}	Exhaust cleaner for Rc 1 1/2: D side exhaust
CU1 ^{Note)}	Exhaust cleaner for Rc 1: U side exhaust
CU2 ^{Note)}	Exhaust cleaner for Rc 1 1/2: U side exhaust
SB ^{Note)}	Direct exhaust with silencer box: Exhaust from both U and D sides
SD ^{Note)}	Direct exhaust with silencer box: D side exhaust
SU ^{Note)}	Direct exhaust with silencer box: U side exhaust

Note) Combination of [C_D] and [S_D] is not possible.

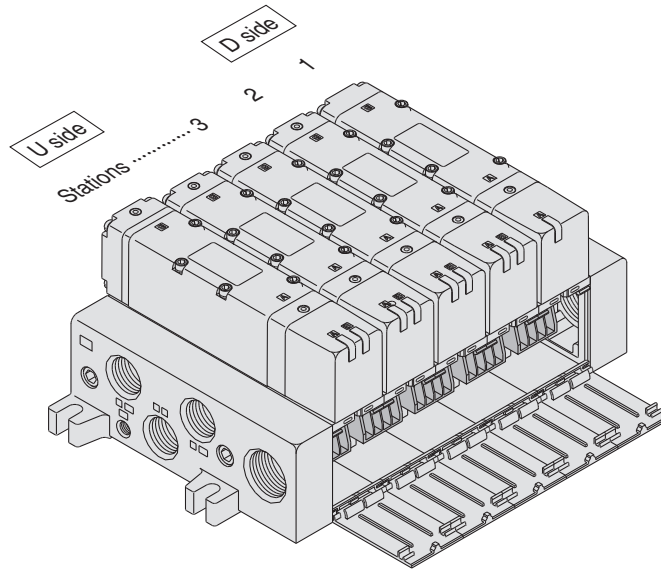

How to Order Valves



How to Order Manifold Assembly

Specify the part numbers for valves and options together beneath the manifold base part number.

<Example>

Individual terminal block kit

- VV5Q51-0503T1[-Q]...1 set—Manifold base part no.
- *VQ5100-51[-Q].....2 sets—Valve part no. (Stations 1 and 2)
- *VQ5200-51[-Q].....2 sets—Valve part no. (Stations 3 and 4)
- *VQ5300-51[-Q].....1 set—Valve part no. (Station 5)

Prefix the asterisk to the part nos. of the valve etc.

Enter in order starting from the first station on the D side. When entry of part numbers becomes complicated, indicate in the manifold specification sheet.

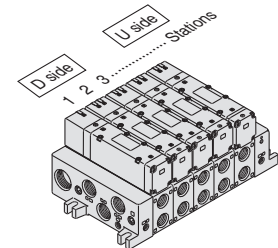

VQ 5 1 0 0 [] - 5 [] [] 1 - Q

Series
5 VQ5000

Type of actuation

1	2-position single
2	2-position double
3	3-position closed centre
4	3-position exhaust centre
5	3-position pressure centre
6	3-position double check

Manual override

—	Non-locking push type (Tool required)
B	Locking type (Tool required)
C	Locking type (Manual)

Light/Surge voltage suppressor

—	Yes
E	Without light, with surge voltage suppressor

Coil voltage

5	24 V DC
6	12 V DC

Function

— Note 1)	Standard (0.95 W)
Y	Low wattage type (0.4 W)
R Note 2)	External pilot

Note 1) When the unit is energised continuously, refer to "Specific Product Precautions 1" on page 88.

Note 2) For details about external pilot specifications, refer to page 82. Combination of external pilot and perfect interface is not possible.

Note 3) When multiple symbols are specified, indicate them alphabetically.

Seal

0	Metal seal
1	Rubber seal

Series VQ5000

T1 Kit (Individual terminal block kit)

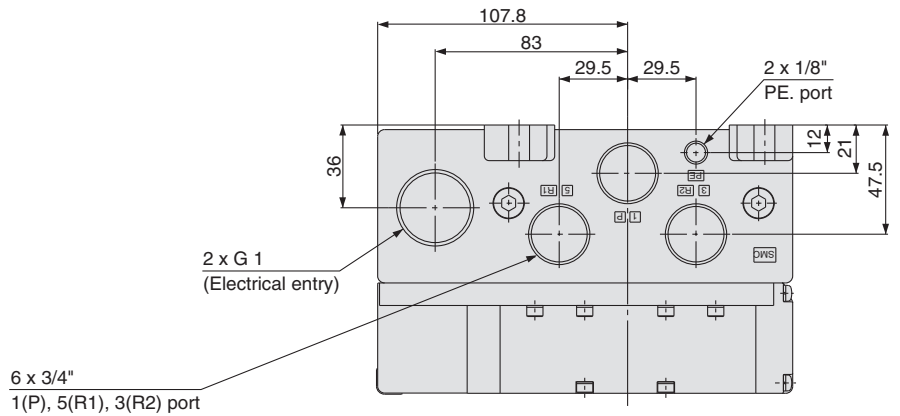
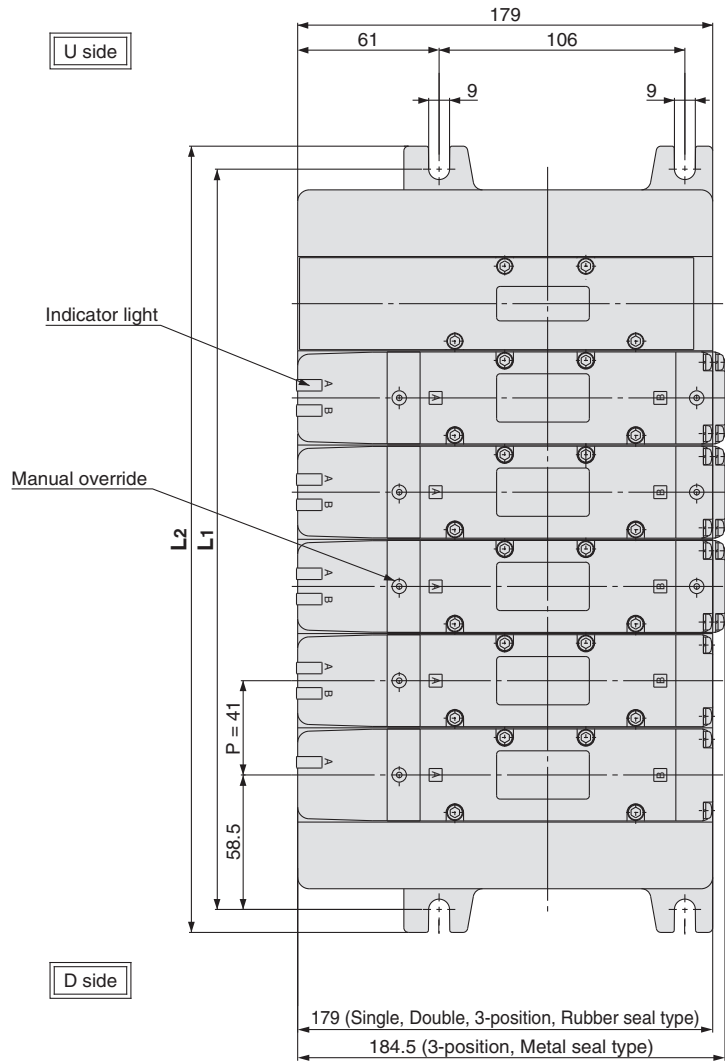
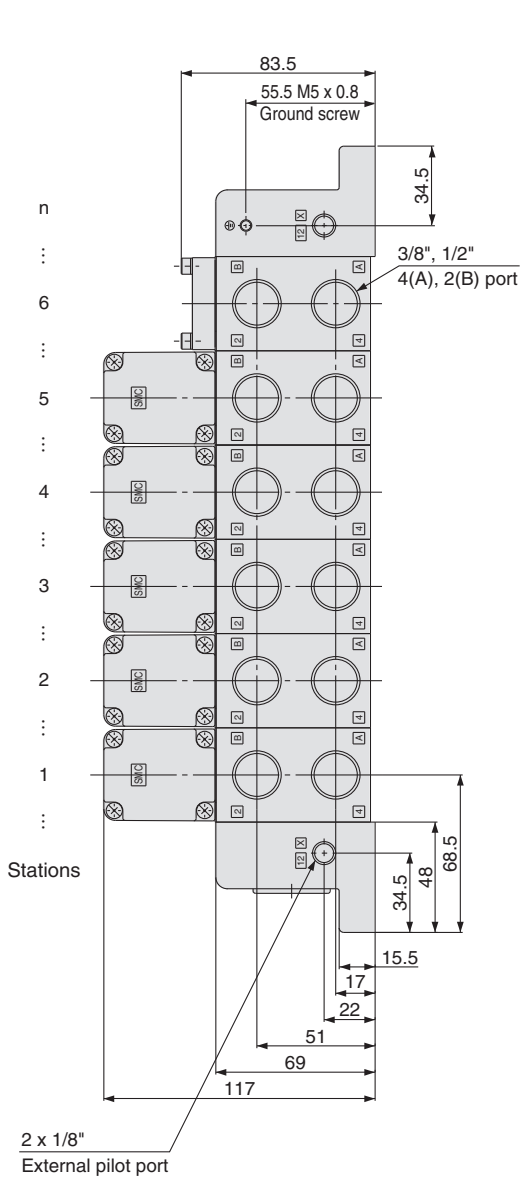

Bottom ported drawing

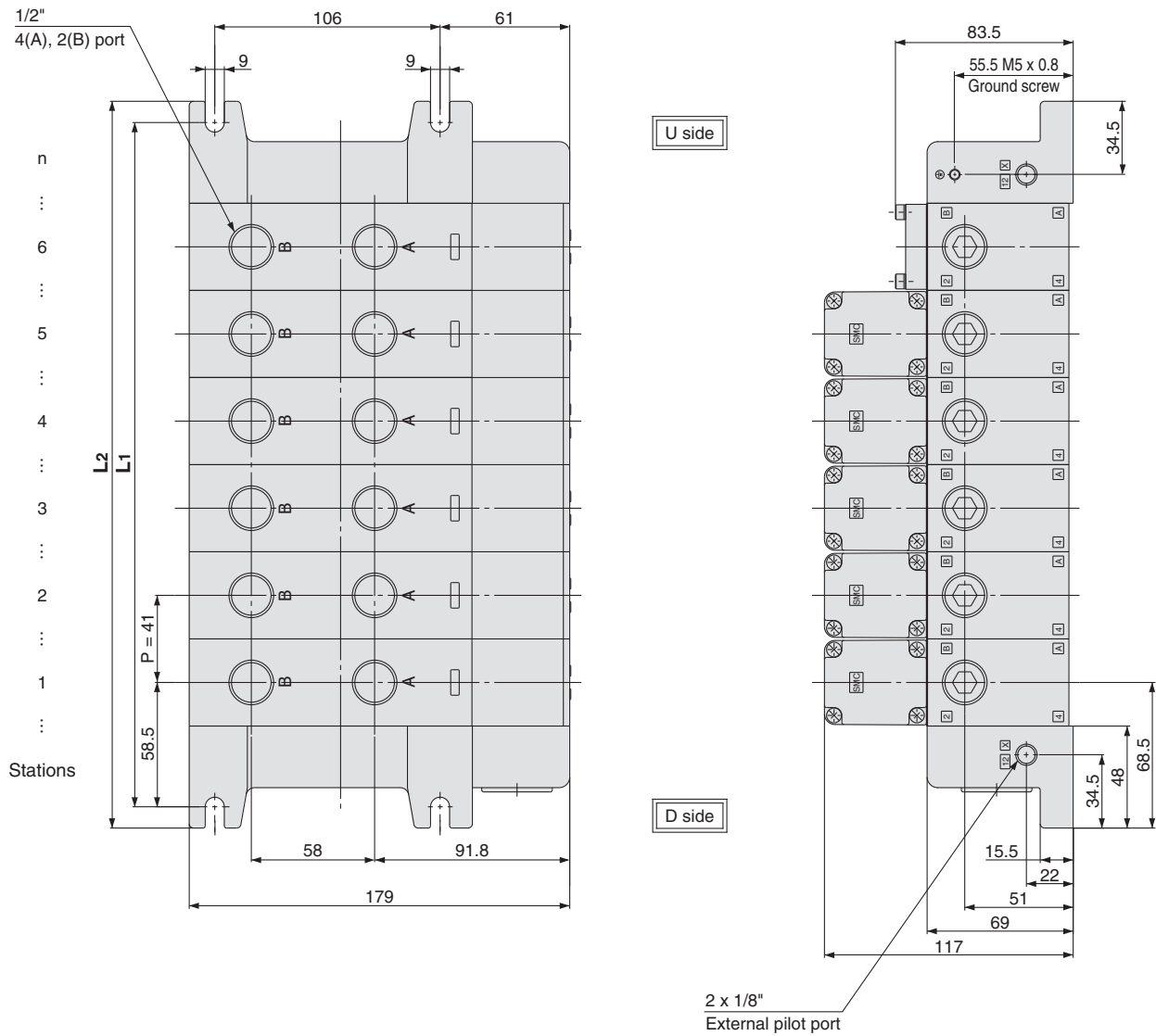

Dimensions

L \ n	1	2	3	4	5	6	7	8	9	10	11	12
L1	117	158	199	240	281	322	363	404	445	486	527	568
L2	137	178	219	260	301	342	383	424	465	506	547	588

Formula: L1 = 41n + 76, L2 = 41n + 96 n: Stations (Maximum 12 stations)

VQ4000

Manifold Options

Semi-standard Specifications

Manifold with Control Unit

Construction

Exploded View of Manifold

VQ5000

Manifold Options

Semi-standard Specifications

Construction

Exploded View of Manifold

Series VQ5000

L Kit (Lead wire cable)

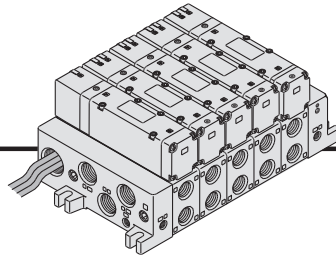

IP65 compliant

- Enclosure IP65 compliant
- Direct electrical entry type available with two or more stations.
- Electrical entry can be selected on either the U side or the D side according to the mounting orientation.
- Maximum stations are 12.

Manifold Specifications

Series	Porting specifications			Applicable stations
	4(A), 2(B) port location	Port size		
		1(P), 5(R1), 3(R2)	4(A), 2(B)	
VQ5000	Side	3/4	3/8	Max. 12 stations
	Bottom		1/2	

Wiring Specifications

Three lead wires are attached to each station regardless of the type of valve which is mounted. The red wire is for COM connection.

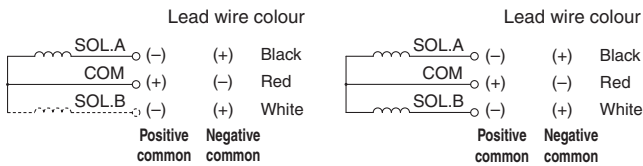

Single solenoid

Double solenoid

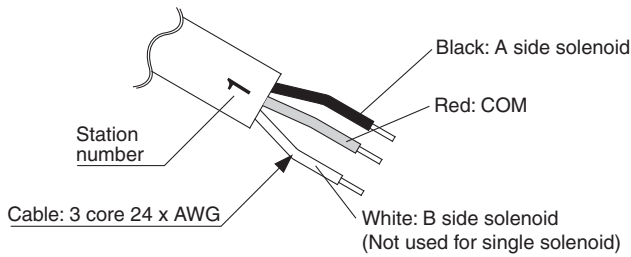

Lead Wire Assembly with Connector

Lead wire length	Part no.
0.6 m	VVQ5000-44A-8-□
1.5 m	VVQ5000-44A-15-□
3 m	VVQ5000-44A-30-□

□: Number of stations 1 to 12

For different lead wire lengths, order a lead wire assembly with connector shown in the table on the right.



How to Order Manifold

VV5Q 5 1 - 08 03 [] L U [] - [] - Q

Series
5 VQ5000

Manifold
1 Plug-in unit

Stations

01	1 station
⋮	⋮
12	12 stations

Cylinder port

03	3/8
04	1/2
B	Bottom ported 1/2
CM	Mixed

Cable (Length)

0	Cable length 0.6 m
1	Cable length 1.5 m
2	Cable length 3 m

Electrical entry

D	D side entry
U	U side entry

Thread type

-	Rc
F	G
N	NPT
T	NPTF

Option

Symbol	Option
-	None
CD1 ^{Note 1)}	Exhaust cleaner for Rc 1: D side exhaust
CD2 ^{Note 1)}	Exhaust cleaner for Rc 1 1/2: D side exhaust
CU1 ^{Note 1)}	Exhaust cleaner for Rc 1: U side exhaust
CU2 ^{Note 1)}	Exhaust cleaner for Rc 1 1/2: U side exhaust
SB	Direct exhaust with silencer box: Exhaust from both U and D sides
SD ^{Note 1)}	Direct exhaust with silencer box: D side exhaust
SU ^{Note 1)}	Direct exhaust with silencer box: U side exhaust
W	IP65 enclosure

Note 1) Combination of [C□□] and [S□] is not possible.

Note 2) When multiple symbols are specified, indicate them alphabetically.

Example) -CD1W.

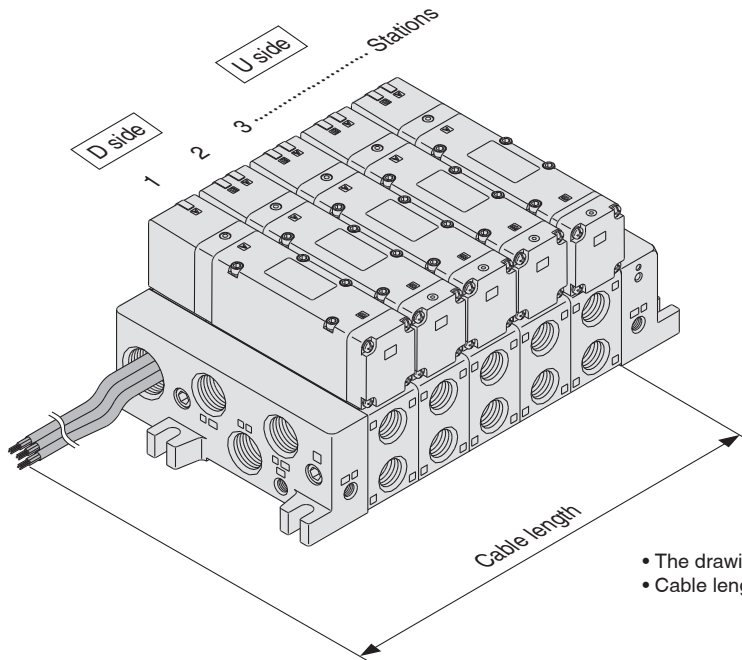

- The drawing shows the electrical entry on the D side.
- Cable length is measured from the valve body.

How to Order Valves



VQ 5 1 0 0 [] - 5 [] [] [] 1 - Q

Series
5 VQ5000

Type of actuation

1	2-position single
2	2-position double
3	3-position closed centre
4	3-position exhaust centre
5	3-position pressure centre
6	3-position double check

Seal

0	Metal seal
1	Rubber seal

Enclosure

—	Dust-protected
W	Dust-tight/ Water-jet-proof(IP65)

Manual override

—	Non-locking push type (Tool required)
B	Locking type (Tool required)
C	Locking type (Manual)

Light/Surge voltage suppressor

—	Yes
E	Without light, with surge voltage suppressor

Coil voltage

5	24 V DC
6	12 V DC

Function

— Note 1)	Standard type (0.95 W)
Y	Low wattage type (0.4 W)
R Note 2)	External pilot

Note 1) When the unit is energised continuously, refer to "Specific Product Precautions 1" on page 88.
 Note 2) For details about external pilot specifications, refer to page 82. Combination of external pilot and perfect interface is not possible.
 Note 3) When multiple symbols are specified, indicate them alphabetically.

How to Order Manifold Assembly

Specify the part numbers for valves and options together beneath the manifold base part number.

<Example>

Lead wire kit with cable (3 m)

- VV5Q51-0503LD2[-Q]...1 set—Manifold base part no.
- *VQ5100-51[-Q].....2 sets—Valve part no. (Stations 1 and 2)
- *VQ5200-51[-Q].....2 sets—Valve part no. (Stations 3 and 4)
- *VQ5300-51[-Q].....1 set—Valve part no. (Station 5)

Prefix the asterisk to the part nos. of the valve etc.

Enter in order starting from the first station on the D side. When entry of part numbers becomes complicated, indicate in the manifold specification sheet.

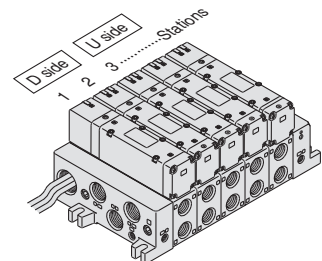

Series VQ5000

Kit (Lead wire cable)

Cable length

- L₀: 600 mm
- L₁: 1500 mm
- L₂: 3000 mm

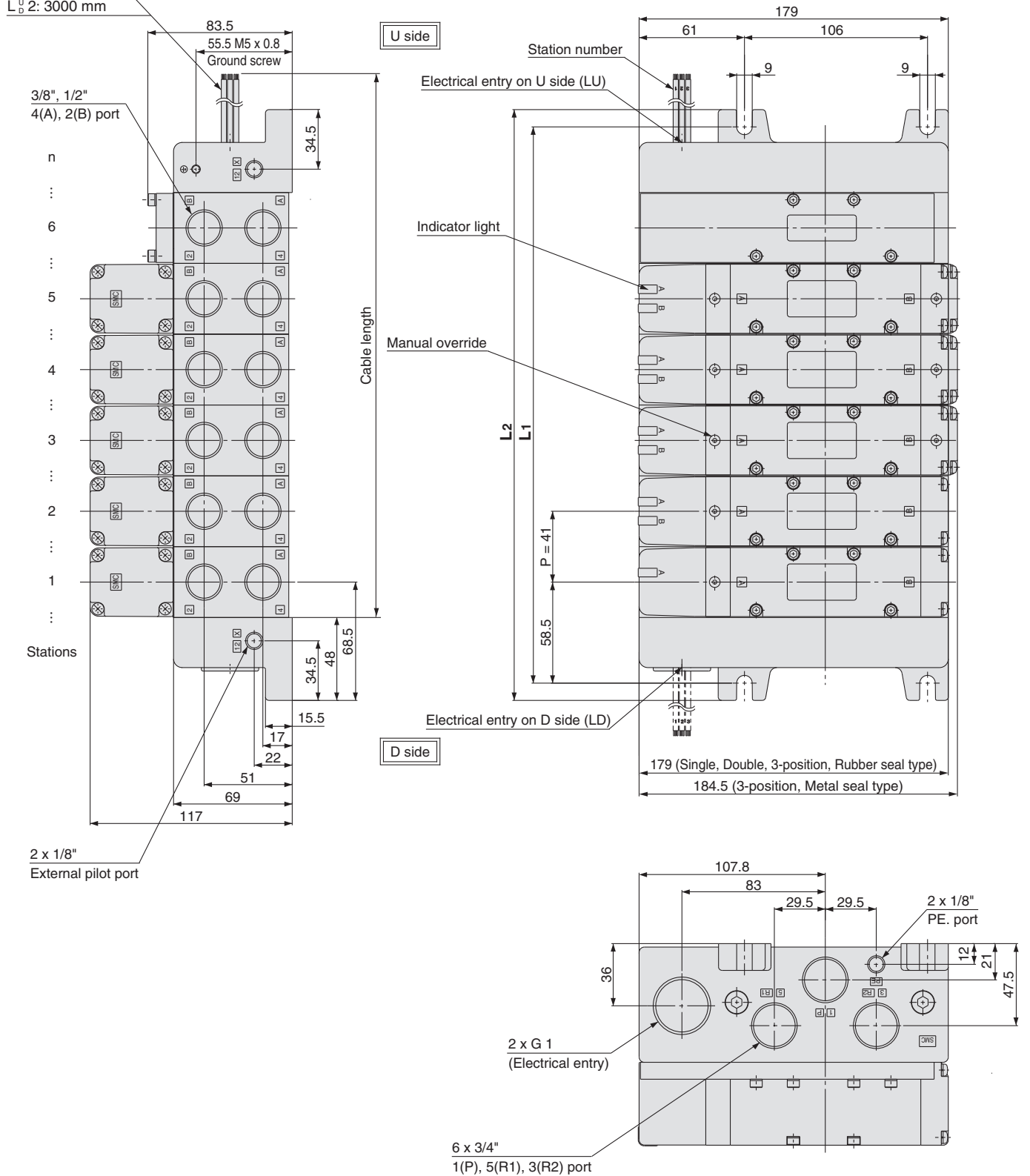

Bottom ported drawing

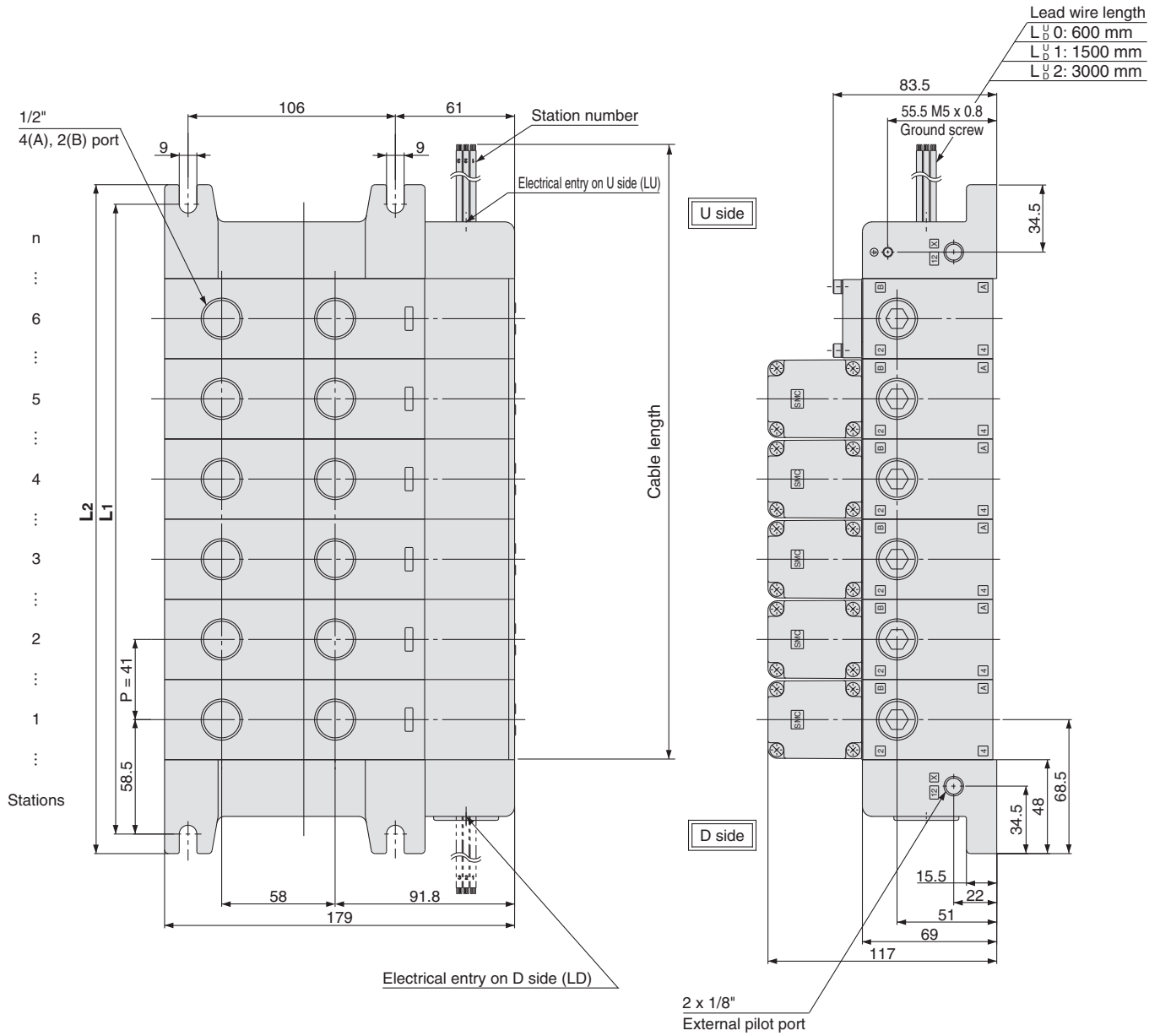

Dimensions

L	n	1	2	3	4	5	6	7	8	9	10	11	12
L ₁		117	158	199	240	281	322	363	404	445	486	527	568
L ₂		137	178	219	260	301	342	383	424	465	506	547	588

Formula: L₁ = 41n + 76, L₂ = 41n + 96 n: Stations (Maximum 12 stations)

VQ4000

Manifold Options

Semi-standard Specifications

Manifold with Control Unit

Construction

Exploded View of Manifold

VQ5000

Manifold Options

Semi-standard Specifications

Construction

Exploded View of Manifold

Series VQ5000

S

Kit (Serial transmission unit): EX123/124 (For Output) Serial Transmission System **IP65 compliant**

- The serial transmission system reduces wiring work, while minimizing wiring and saving space.

Manifold Specifications

Series	Porting specifications			Applicable stations
	4(A), 2(B) port location	Port size		
		1(P), 5(R1), 3(R2)	4(A), 2(B)	
VQ5000	Side	3/4	3/8 1/2	Max. 12 stations
	Bottom		1/2	

- Double wiring (connected to SOL. A and SOL. B) is adopted for the internal wiring of each station, regardless of valve and option types. Mixed single and double wiring is available as a semi-standard specification.

Item	Specifications
External power supply	24 V DC +10 %, -5 %
Current consumption (Internal unit)	0.1 A



How to Order Manifold

VV5Q 5 1 - 08 03 S U Q - - Q

Series

5	VQ5000
---	--------

Manifold

1	Plug-in unit
---	--------------

Stations

02	2 stations
⋮	⋮
12	12 stations

Note) One station is used for mounting SI Unit.
The number of stations is the number of manifold valves plus one station for SI Unit. For 10 stations or more, specify the wiring specifications by means of the manifold specification sheet.

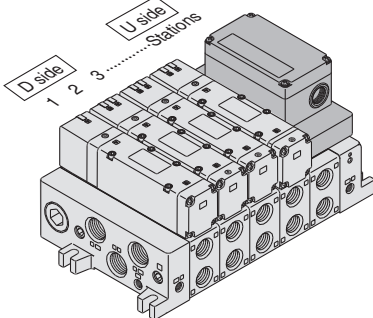

* Stations are counted starting from the first station on the D side.

Cylinder port

03	3/8
04	1/2
B	Bottom ported 1/2
CM	Mixed

Thread type

—	Rc
F	G
N	NPT
T	NPTF

SI Unit mounting position

D	D side mounting
U	U side mounting

Option

Symbol	Option
—	None
CD1 Note 2)	Exhaust cleaner for Rc 1: D side exhaust
CD2 Note 2)	Exhaust cleaner for Rc 1 1/2: D side exhaust
CU1 Note 2)	Exhaust cleaner for Rc 1: U side exhaust
CU2 Note 2)	Exhaust cleaner for Rc 1 1/2: U side exhaust
K Note 3)	Special wiring specifications (except double wiring specification, 10 stations or more)
SD Note 2)	Direct exhaust with silencer box: D side exhaust
SU Note 2)	Direct exhaust with silencer box: U side exhaust
W	IP65 enclosure

Note 1) When multiple symbols are specified, indicate them alphabetically.
Example) -CD1K

Note 2) Combination of [C_U□] and [S_U□] is not possible.

Note 3) Specify the wiring specifications on the manifold specification sheet.

SI Unit

0	Without SI Unit
Q	DeviceNet® (16 output points)
R1	OMRON Corp.: CompoBus/S System (16 output points)
R2	OMRON Corp.: CompoBus/S System (8 output points)
V	CC-LINK (16 output points)

SI Unit Part No.

Symbol	Protocol type	SI Unit part no.	Page
Q	DeviceNet® (16 output points)	D side: EX124D-SDN1 U side: EX124U-SDN1	86
R1	OMRON Corp.: CompoBus/S System (16 output points)	D side: EX124D-SCS1 U side: EX124U-SCS1	
R2	OMRON Corp.: CompoBus/S System (8 output points)	D side: EX124D-SCS2 U side: EX124U-SCS2	
V	CC-LINK (16 output points)	D side: EX124D-SMJ1 U side: EX124U-SMJ1	

Refer to the catalogues on SMC website, and the Operation Manual for the details of EX123 Integrated-type (For Output) Serial Transmission System. Please download the Operation Manual via SMC website, <http://www.smc.eu>



How to Order Valves

VQ 5 1 0 0 [] - 5 [] [] [] 1 - Q

Series

5	VQ5000
---	--------

Type of actuation

1	2-position single
2	2-position double
3	3-position closed centre
4	3-position exhaust centre
5	3-position pressure centre
6	3-position double check

Seal

0	Metal seal
1	Rubber seal

Function

— Note 1)	Standard (0.95 W)
Y	Low wattage type (0.4 W)
R Note 2)	External pilot

- Note 1) When the unit is energised continuously, refer to "Specific Product Precautions 1" on page 88.
 Note 2) For details about external pilot specifications, refer to page 82. Combination of external pilot and perfect interface is not possible.
 Note 3) When multiple symbols are specified, indicate them alphabetically.

Enclosure

—	Dust-protected
W	Dust-tight/ Water-jet-proof (IP65)

Manual override

—	Non-locking push type (Tool required)
B	Locking type (Tool required)
C	Locking type (Manual)

Light/Surge voltage suppressor

—	Yes
E	Without light, with surge voltage suppressor

Coil voltage

5	24 V DC
---	---------

How to Order Manifold Assembly

Specify the part numbers for valves and options together beneath the manifold base part number.

<Example>

VV5Q51-0603SUQ[-Q]...1 set—Manifold base part no.
 *VQ5100-51[-Q].....2 sets—Valve part no. (Stations 1 and 2)
 *VQ5200-51[-Q].....2 sets—Valve part no. (Stations 3 and 4)
 *VQ5300-51[-Q].....1 set—Valve part no. (Station 5)

Prefix the asterisk to the part nos. of the valve etc.

Enter in order starting from the first station on the D side. When entry of part numbers becomes complicated, indicate in the manifold specification sheet.

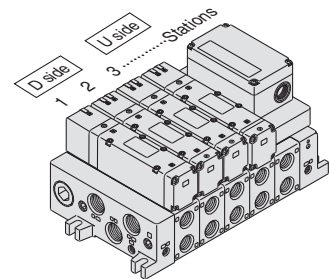

VQ4000

Manifold Options

Semi-standard Specifications

Manifold with Control Unit

Construction

Exploded View of Manifold

VQ5000

Manifold Options

Semi-standard Specifications

Construction

Exploded View of Manifold

Series VQ5000

S

Kit (Serial transmission unit): EX123/124 Integrated-type (For Output) Serial Transmission System

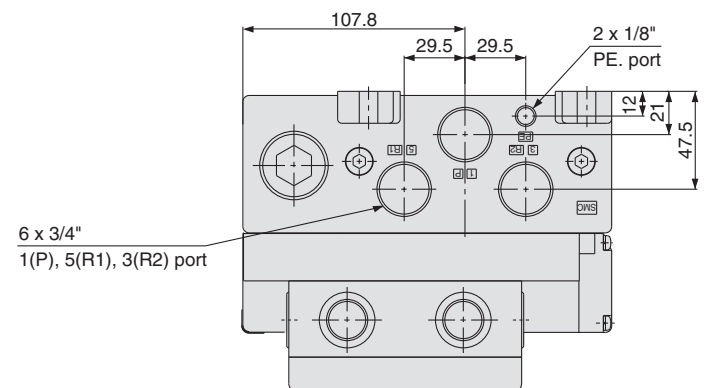
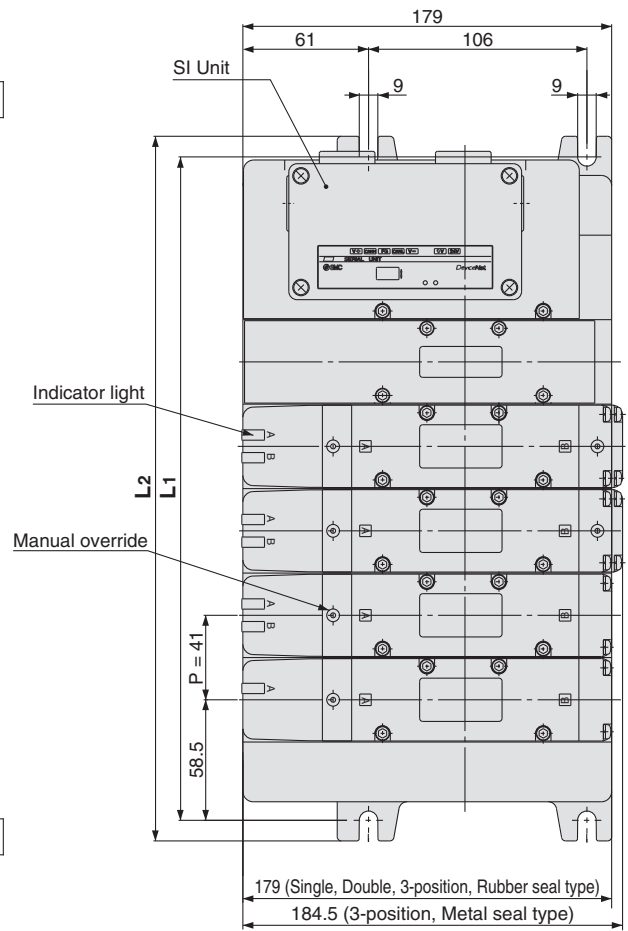
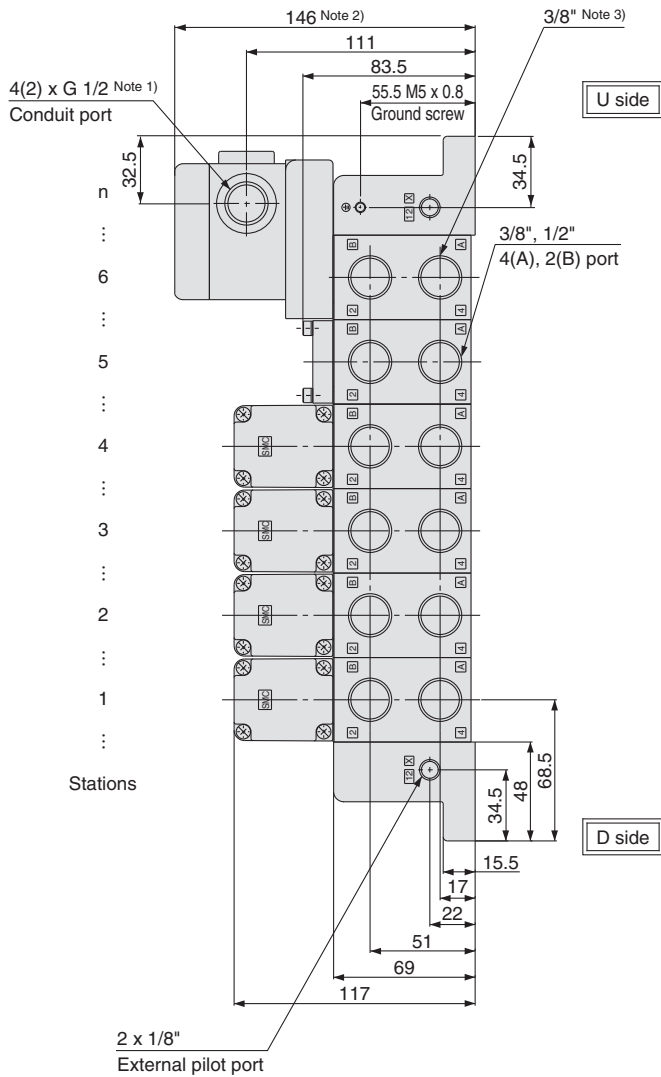

Note 1) When the SI Unit is EX124D(U), conduit port (G 1/2) will be 4 locations. In the case of EX123D(U), conduit port will be 2 locations.

Note 2) In the case of EX124D(U)-SMJ1, this dimension becomes 149.

Note 3) 4(A) and 2(B) port at the bottom of the SI Unit are 3/8".

Bottom port drawing

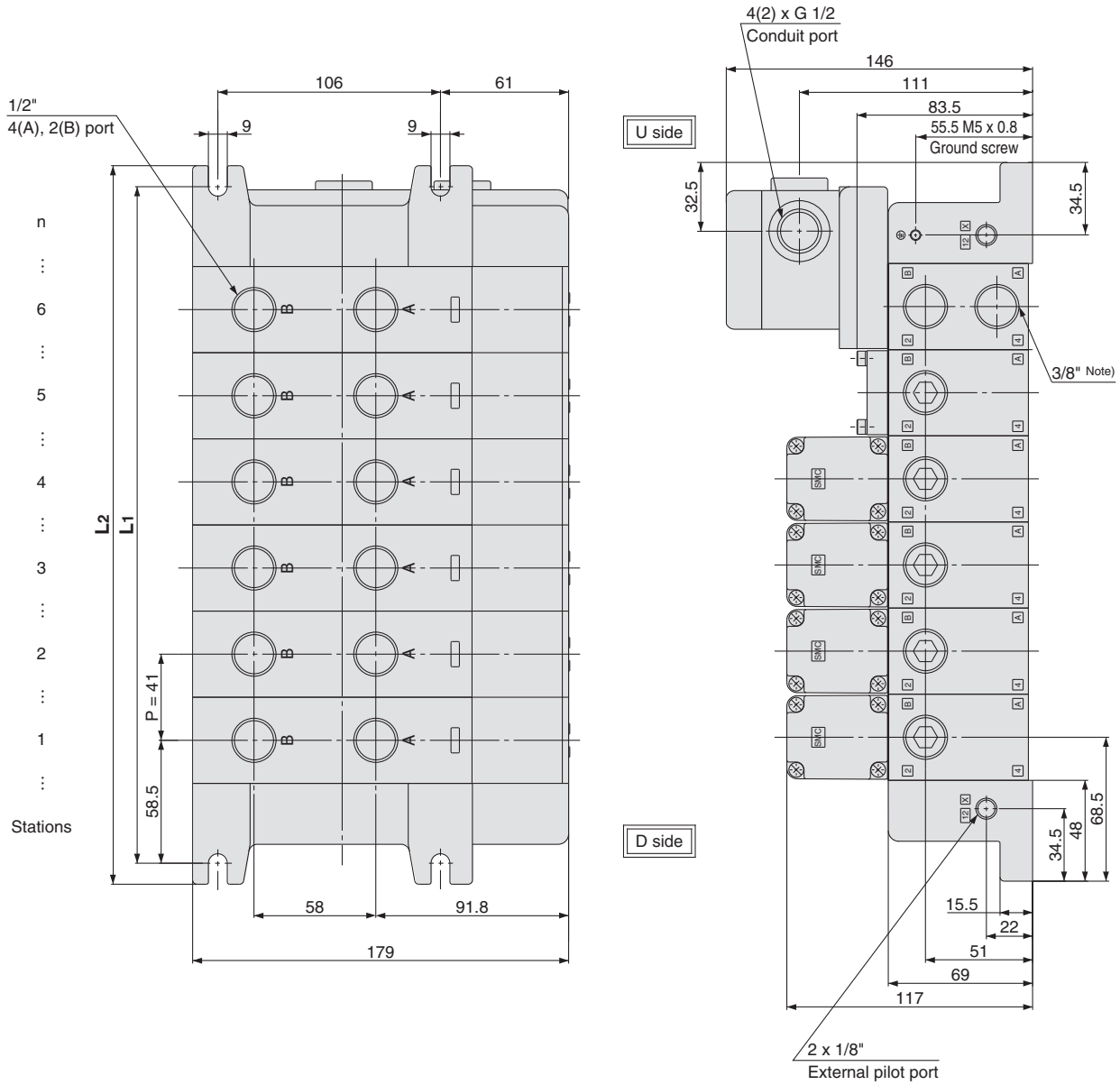

Note) 4(A) and 2(B) port at the bottom of the SI Unit are 3/8".

Dimensions

L	n	[mm]										
		2	3	4	5	6	7	8	9	10	11	12
L1		158	199	240	281	322	363	404	445	486	527	568
L2		178	219	260	301	342	383	424	465	506	547	588

Formula: L1 = 41n + 76, L2 = 41n + 96

n: Stations (Maximum 12 stations)

* Including 1 station for mounting SI Unit.

Base Mounted

Plug Lead Unit: C Kit (Connector Kit)

Series VQ5000

How to Order Manifold

VV5Q 5 5 - 08 03 [] C - [] - Q

Series

5	VQ5000
---	--------

Manifold

5	Plug lead unit
---	----------------

Stations

01	1 station
...	...
12	12 stations

Cylinder port

03	3/8
04	1/2
B	Bottom ported 1/2
CM	Mixed

Thread type

—	Rc
F	G
N	NPT
T	NPTF

Kit type

C Kit (Connector)

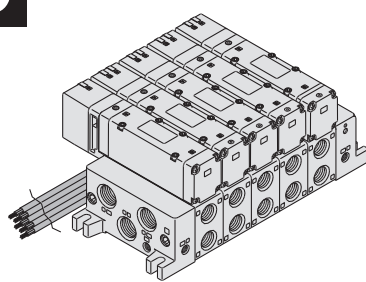

C	Connector kit	Max. 12 stations
---	---------------	------------------

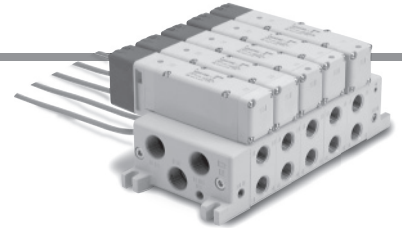

Option

Symbol	Option
—	None
CD1 <small>Note 1)</small>	Exhaust cleaner for Rc 1: D side exhaust
CD2 <small>Note 1)</small>	Exhaust cleaner for Rc 1 1/2: D side exhaust
CU1 <small>Note 1)</small>	Exhaust cleaner for Rc 1: U side exhaust
CU2 <small>Note 1)</small>	Exhaust cleaner for Rc 1 1/2: U side exhaust
SB <small>Note 1)</small>	Direct exhaust with silencer box: Exhaust from both U and D sides
SD <small>Note 1)</small>	Direct exhaust with silencer box: D side exhaust
SU <small>Note 1)</small>	Direct exhaust with silencer box: U side exhaust
W	IP65 enclosure

Note 1) Combination of [C_D^U] and [S_D^U] is not possible. Also, exhaust cleaner is not attached. Please order it separately.

Refer to page 89 (Grommet type) for wiring specifications.

How to Order Valves

VQ 5 1 5 0 [] - 5 G [] [] [] 1 - Q

Series

5	VQ5000
---	--------

Type of actuation

1	2-position single
2	2-position double
3	3-position closed centre
4	3-position exhaust centre
5	3-position pressure centre
6	3-position double check

Seal

0	Metal seal
1	Rubber seal

Function

— <small>Note 1)</small>	Standard (0.95 W)
Y	Low wattage type (0.4 W)
R <small>Note 2)</small>	External pilot

Coil voltage

5	24 V DC
6	12 V DC

Note 1) When the unit is energised continuously, refer to "Specific Product Precautions 1" on page 88.
 Note 2) For details about external pilot specifications, refer to page 82. Combination of external pilot and perfect interface is not possible.
 Note 3) When multiple symbols are specified, indicate them alphabetically.

Enclosure

—	Dust-protected
W	Dust-tight/ Water-jet-proof (IP65)

Manual override

—:	Non-locking push type (Tool required)
B:	Locking type (Tool required)
C:	Locking type (Manual)

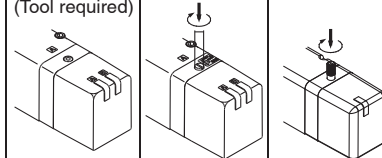

Light/Surge voltage suppressor

—	Yes
E	Without light, with surge voltage suppressor

Electrical entry

G	Lead wire length 0.6 m
H	Lead wire length 1.5 m

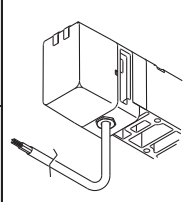

How to Order Manifold Assembly

Specify the part numbers for valves and options together beneath the manifold base part number.

<Example>
 Connector kit
 VV5Q55-05042C[-Q]...1 set—Manifold base part no.
 *VQ5150-5G1[-Q].....2 sets—Valve part no. (Stations 1 and 2)
 *VQ5250-5G1[-Q].....2 sets—Valve part no. (Stations 3 and 4)
 *VQ5350-5G1[-Q].....1 set—Valve part no. (Station 5)

Prefix the asterisk to the part nos. of the valve etc.

Enter in order starting from the first station on the D side. When entry of part numbers becomes complicated, indicate in the manifold specification sheet.

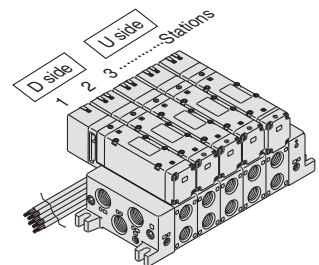

Manifold Specifications

Series	Base model	Type of connection	Porting specifications			Maximum applicable stations	Applicable valve	Weight [kg] (Formula)
			4(A), 2(B) port location	Port size				
				1(P), 5(R1), 3(R2)	4(A), 2(B)			
VQ5000	VV5Q55-□□□	■ C kit-Grommet	Side	3/4 Option Direct exhaust with silencer box	3/8 1/2	2 to 12 stations	VQ5□50 VQ5□51	0.58n + 0.9 • Not including valve weight.
			Bottom		1/2			

Flow-rate Characteristics at the Number of Manifold Stations (Operated individually)

n: Stations

Model	Passage/Stations	Station 1	Station 5	Station 10	
2-position metal seal VQ5 ₂ 00	1 → 4/2 (P → A/B)	C [dm ³ /(s-bar)]	11	11	11
		b	0.24	0.24	0.24
		Cv	2.7	2.7	2.7
		Q [l/min (ANR)] note 2)	2696	2696	2696
	4/2 → 5/3 (A/B → EA/EB)	C [dm ³ /(s-bar)]	12	12	12
		b	0.14	0.14	0.14
Cv		2.9	2.9	2.9	
2-position rubber seal VQ5 ₂ 01	1 → 4/2 (P → A/B)	C [dm ³ /(s-bar)]	12	12	12
		b	0.33	0.33	0.33
		Cv	3.4	3.4	3.4
		Q [l/min (ANR)] note 2)	3111	3111	3111
	4/2 → 5/3 (A/B → EA/EB)	C [dm ³ /(s-bar)]	16	16	16
		b	0.33	0.33	0.33
		Cv	4.4	4.4	4.4
		Q [l/min (ANR)] note 2)	4148	4148	4148

Note 1) For port size 1/2 Note 2) These values have been calculated according to ISO 6358 and indicate the flow rate under standard conditions with an inlet pressure of 0.6 MPa (relative pressure) and a pressure drop of 0.1 MPa.

Manifold Options

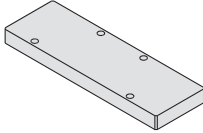
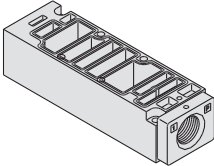
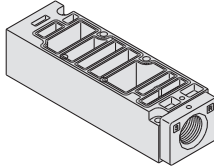
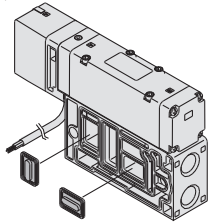
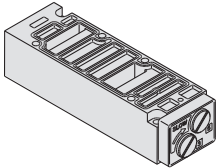
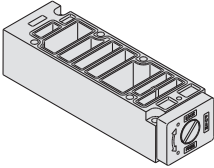
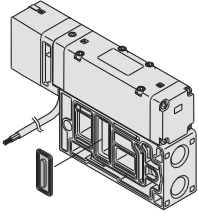
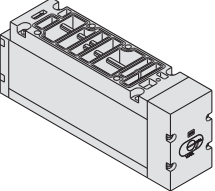
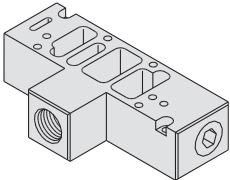
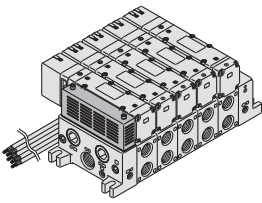
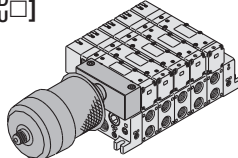
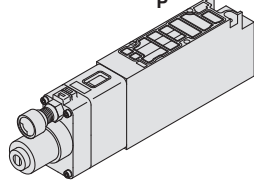
Blanking plate assembly VVQ5000-10A-5 	Individual SUP spacer VVQ5000-P-5- ⁰³ ₀₄ 	Individual EXH spacer VVQ5000-R-5- ⁰³ ₀₄ 	EXH block plate VVQ5000-16A-2 
Restrictor spacer VVQ5000-20A-5 	SUP stop valve spacer VVQ5000-37A-5 	SUP block plate VVQ5000-16A-1 	Double check spacer with residual pressure exhaust VVQ5000-25A-5 
Release valve spacer: For D side mounting VVQ5000-24A-5D 	Direct exhaust with silencer box [-S _U ^D] 	Manifold mounted exhaust cleaner [-C _U ^D □] 	Interface regulator (P, A, B port regulation) ARBQ5000-00- ^A _P -5 

- Refer to pages 77 to 81 for detailed dimensions of each option.
- For replacement parts, refer to page 86.

Bottom ported drawing

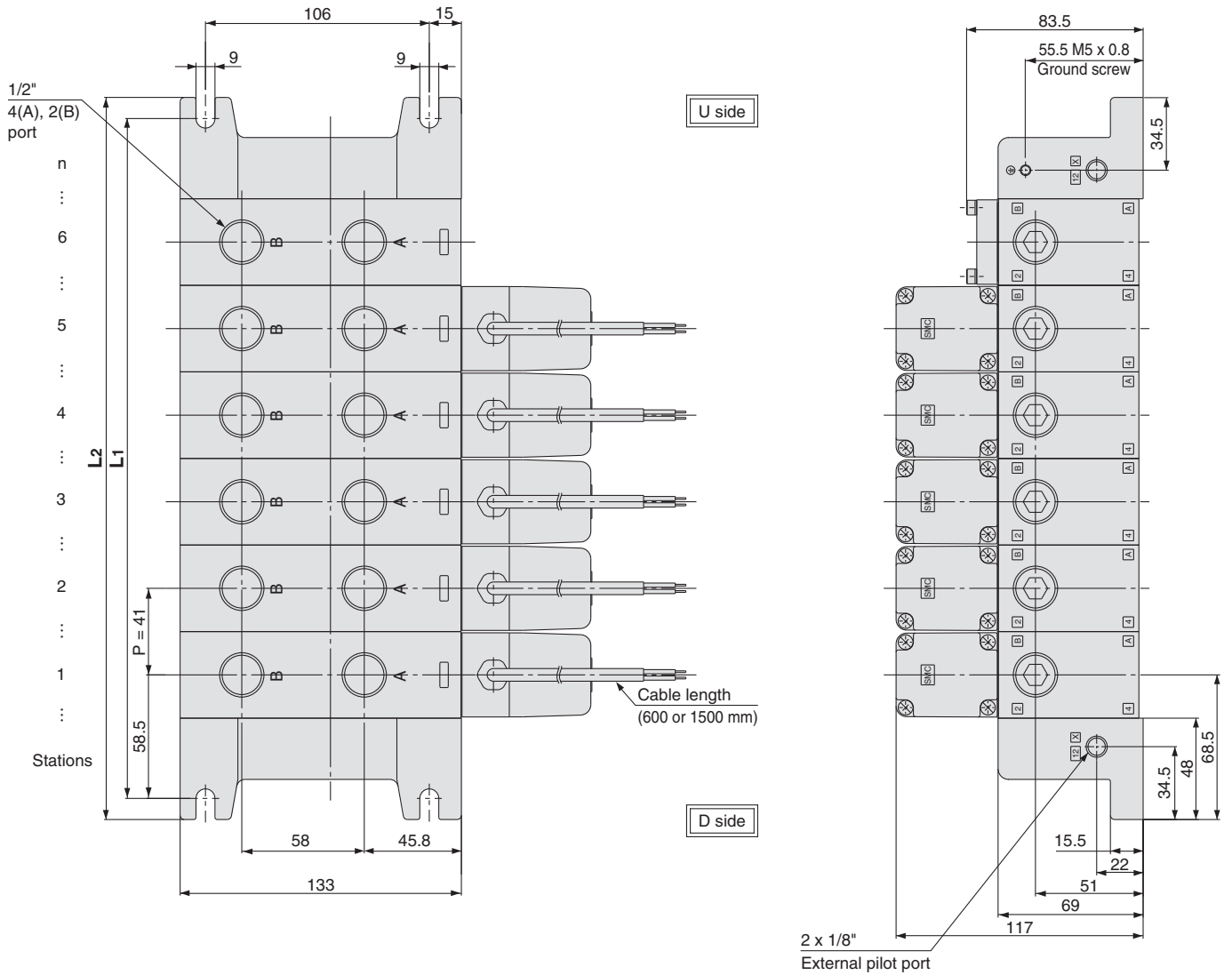

Dimensions

L \ n	1	2	3	4	5	6	7	8	9	10	11	12
L1	117	158	199	240	281	322	363	404	445	486	527	568
L2	137	178	219	260	301	342	383	424	465	506	547	588

Formula: $L_1 = 41n + 76$, $L_2 = 41n + 96$ n: Stations (Maximum 12 stations)

VQ4000

Manifold Options

Semi-standard Specifications

Manifold with Control Unit

Construction

Exploded View of Manifold

VQ5000

Manifold Options

Semi-standard Specifications

Construction

Exploded View of Manifold

Series VQ5000 Manifold Options

Manifold Option Parts

Blanking plate assembly

VVQ5000-10A-1 (Plug-in type)
VVQ5000-10A-5 (Plug lead type)

It is used by attaching on the manifold block for being prepared for removing a valve for maintenance reasons or planning to mount a spare valve etc.

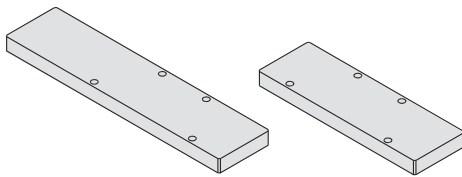

Plug-in type

Plug lead type

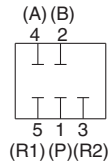

Circuit diagram

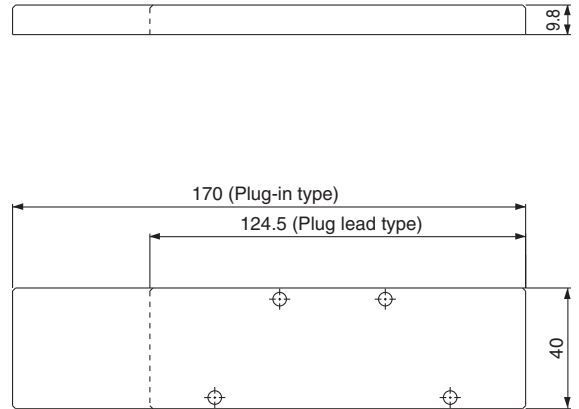

Individual SUP spacer

VVQ5000 - P - 1 - 03

Manifold		Port size		Thread type	
1	Plug-in type	03	3/8	—	Rc
5	Plug lead type	04	1/2	F	G
				N	NPT
				T	NPTF

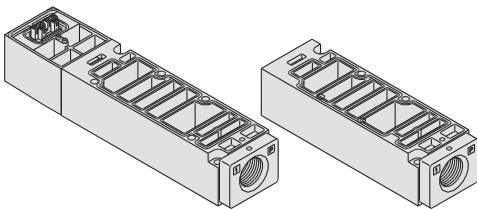

Plug-in type

Plug lead type

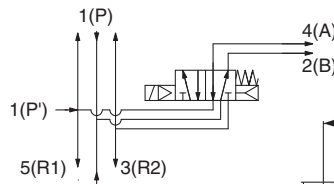

Circuit diagram

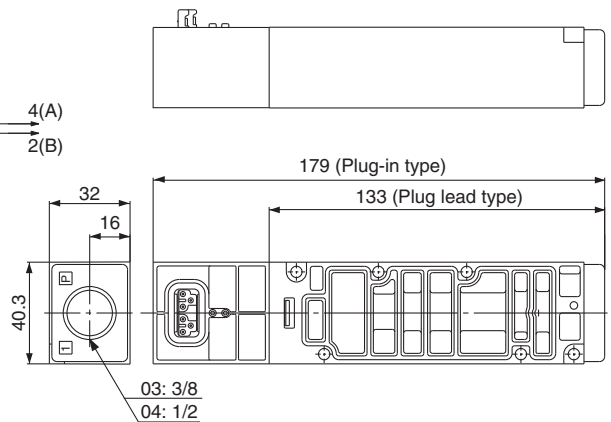

Individual EXH spacer

VVQ5000 - R - 1 - 03

Manifold		Port size		Thread type	
1	Plug-in type	03	3/8	—	Rc
5	Plug lead type	04	1/2	F	G
				N	NPT
				T	NPTF

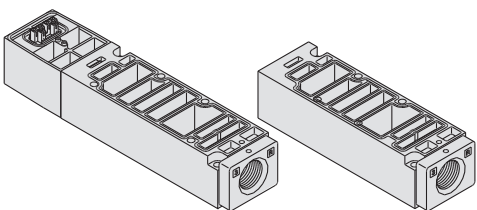

Plug-in type

Plug lead type

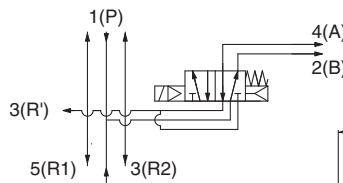

Circuit diagram

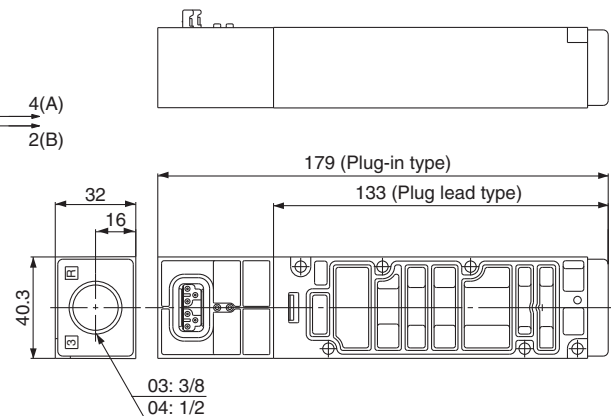

Restrictor spacer

VVQ5000-20A-1 (Plug-in type)
VVQ5000-20A-5 (Plug lead type)

A restrictor spacer is mounted on a manifold block to control cylinder speed by throttling exhaust air flow.

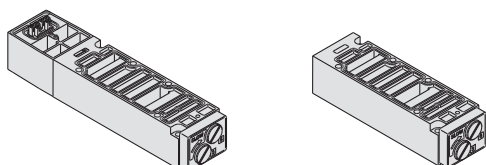

Plug-in type

Plug lead type

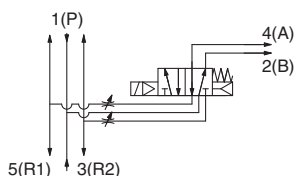

Circuit diagram

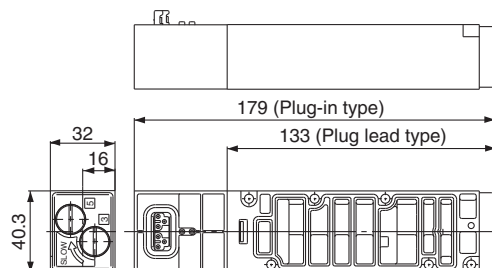

Note 1) A certain amount of leakage is allowed in the products' specifications. Tightening the needle to reduce leakage to zero may result in equipment damage.
 Note 2) Products mentioned in this catalogue are retainer types, so the needle is not removed completely. Over rotation will cause damage.

SUP stop valve spacer

VVQ5000-37A-1 (Plug-in type)
VVQ5000-37A-5 (Plug lead type)

A SUP stop valve spacer is mounted on a manifold block, making it possible to individually shut off supply air to each valve.

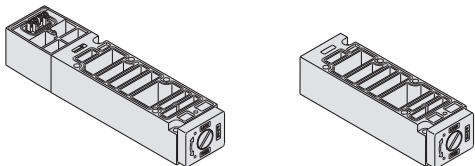

Plug-in type

Plug lead type

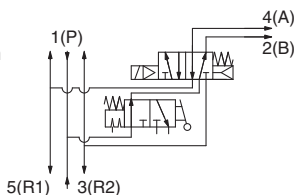

Circuit diagram

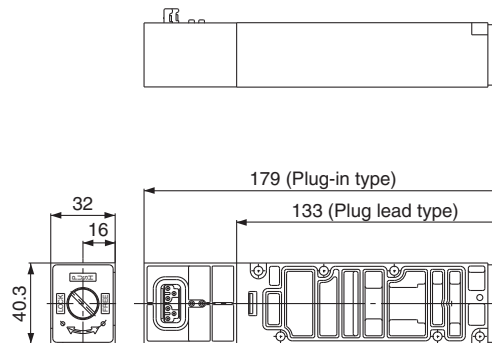

Release valve spacer: For D side mounting

VVQ5000-24A-1D (Plug-in type)
VVQ5000-24A-5D (Plug lead type)

A VQ51□□ (single) valve can be used as an air release valve by combining it with a release valve spacer.
 Note) 2-position double and 3-position cannot be mounted.

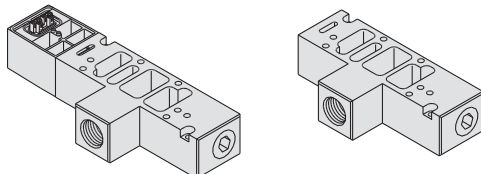

Plug-in type

Plug lead type

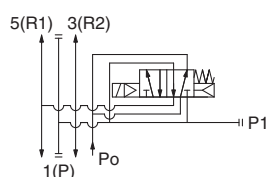

Circuit diagram

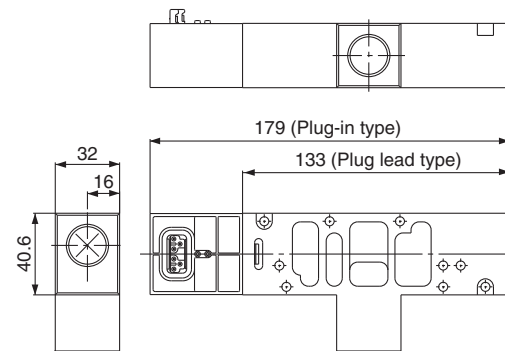

SUP block plate

VVQ5000-16A-1

EXH block plate

VVQ5000-16A-2

When supplying two different pressures to one manifold, this is used to shut off between stations with different pressures.

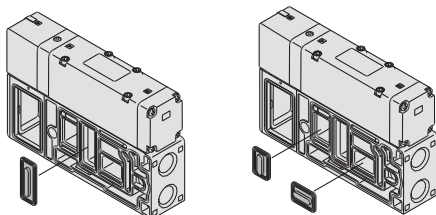

<SUP blocking plate>

<EXH blocking plate>

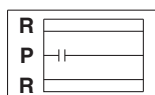
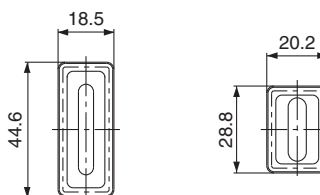

SUP passage blocked

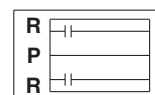

EXH passage blocked

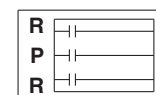

SUP/EXH passage blocked

Series VQ5000

Manifold Option Parts

Direct exhaust with silencer box

VV5Q5 $\frac{1}{5}$ -□□□-SD (D side exhaust)

VV5Q5 $\frac{1}{5}$ -□□□-SU (U side exhaust)

VV5Q5 $\frac{1}{5}$ -□□□-SB (Exhaust from both sides)

The EXH outlet is placed on the top side of the manifold end plate. The built-in silencer provides highly effective noise reduction. (Noise reduction of 35 dB(A) or more)

Note) Note that when excessive drainage occurs in the air supply, the drainage will be released along with the exhaust.

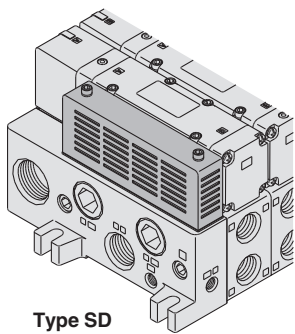

Type SD

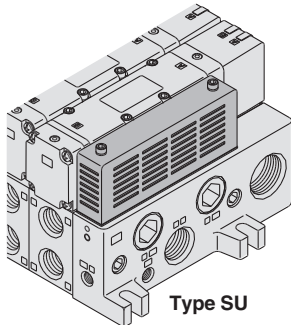

Type SU

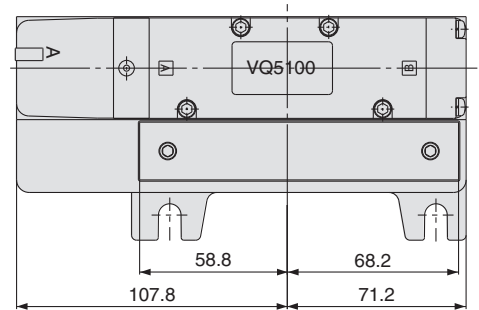
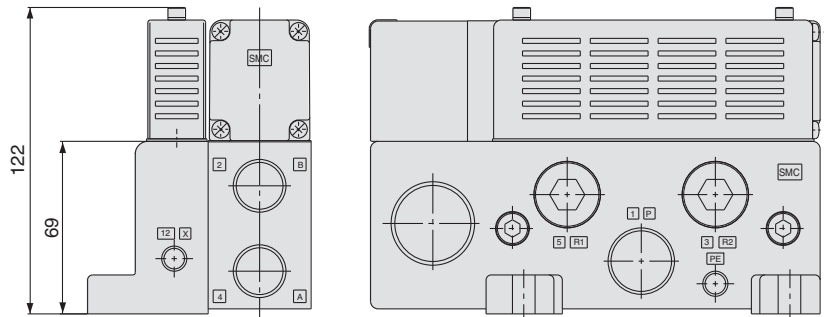

Note) Figure shows VV5Q51-□□□-SD.

• Silencer box assembly: VVQ5000-75A (With gasket, screw)

Double check spacer with residual pressure exhaust

VVQ5000-25A-1 (Plug-in type)

VVQ5000-25A-5 (Plug lead type)

Can hold an intermediate cylinder position for an extended time.

When combined with a double check spacer with built-in double check valve, it is unaffected by air leakage between the spool valves, making it possible to hold a cylinder at an intermediate stopping position for an extended time.

Besides, combination between 2-position solenoid valve (VQ5 $\frac{1}{2}$ □□) and double check spacer can be used for drop prevention.

Plug-in type

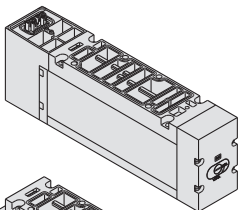

Plug lead type

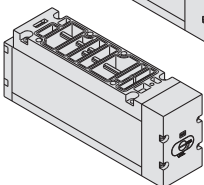

Specifications

Double check spacer part no.	VVQ5000-25A- $\frac{1}{5}$	
	Intermediate stop	Drop prevention
Applicable solenoid valve	VQ54□□	VQ5 $\frac{1}{2}$ □□

⚠ Caution

Handling Precautions

- In the case of 3-position double check (VQ56 $\frac{3}{5}$ □□), check the leakage from piping and fittings in between valve and cylinder by means of synthetic detergent solutions, and ensure that there is no such leakage found there. Also, check the leakage from cylinder seal and piston seal. If there is any leakage, sometimes the cylinder, when valve is de-energised, can move without stopping at intermediate position.
- If exhaust side of double check spacer is narrowed down, this causes a decrease in intermediate stop accuracy and may malfunction.
- Combination with 3-position valves "VQ5 $\frac{3}{5}$ □□" is not possible.
- Set the cylinder load so that the cylinder pressure will be within two times that of the supply pressure.

Manifold mounted exhaust cleaner

VV5Q5 $\frac{1}{5}$ - □□□-CD $\frac{1}{2}$ (D side mounting)

VV5Q5 $\frac{1}{5}$ - □□□-CU $\frac{1}{2}$ (U side mounting)

An adapter plate for exhaust cleaner mounting is provided on the top of the manifold end plate. The exhaust cleaner collects drainage and oil mist (99.9 % or more) and is highly effective for noise reduction.

(Noise reduction of 35 dB(A) or more)

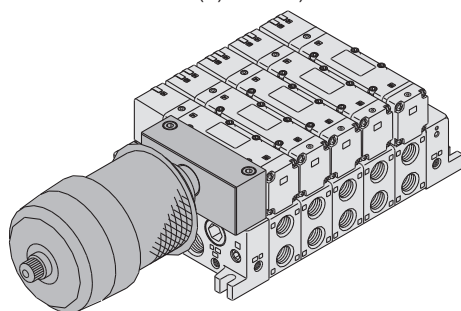

Plug-in type

Applicable exhaust cleaners

AMC610-10 (Port size Rc 1), AMC810-14 (Port size Rc 1 1/2)

Note 1) Exhaust cleaner: AMC610-10 and AMC810-14 are not included. Please order it separately.

Note 2) Mount so that the exhaust cleaner is at the lower side.

Note 3) For details about the exhaust cleaner, refer to the catalogue on SMC website www.smc.eu.

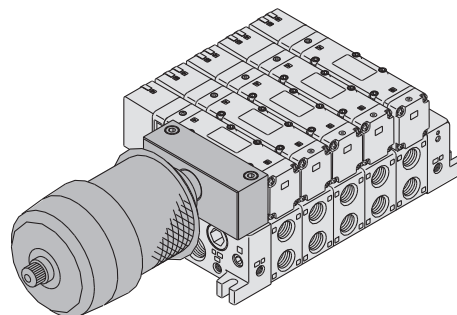

Plug lead type

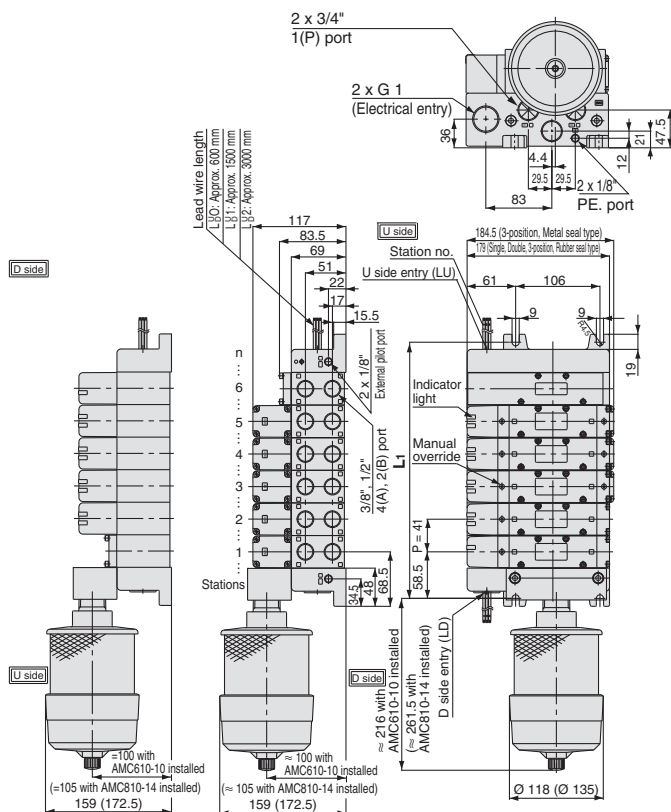

Dimensions

L	n	2	3	4	5	6	7	8	9	10	11	12
L1		158	199	240	281	322	363	404	445	486	527	568
L2		178	219	260	301	342	383	424	465	506	547	588

Formula: L1 = 41n + 76, L2 = 41n + 96
 n: Stations (Maximum 12 stations)

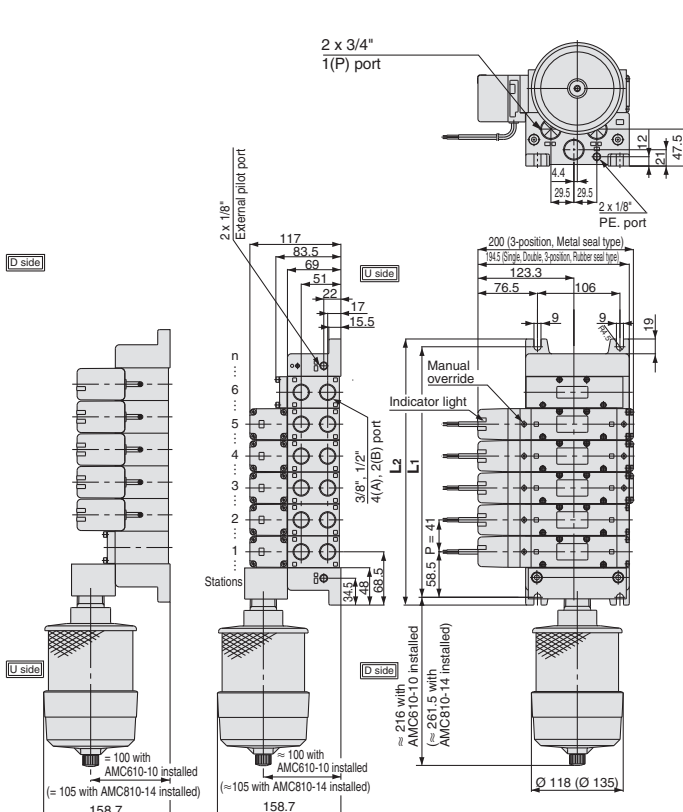

Dimensions

L	n	2	3	4	5	6	7	8	9	10	11	12
L1		158	199	240	281	322	363	404	445	486	527	568
L2		178	219	260	301	342	383	424	465	506	547	588

Formula: L1 = 41n + 76, L2 = 41n + 96
 n: Stations (Maximum 12 stations)

Series VQ5000

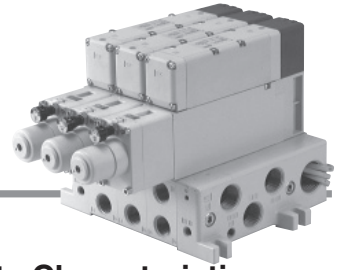

Manifold Option Parts

Interface regulator (P, A, B port regulation)

ARBQ5000-00-□-1 (Plug-in type)

ARBQ5000-00-□-5 (Plug lead type)

By mounting a spacer regulator on the manifold block, it enables to regulate pressure per every valve.

Specifications

Interface regulator		ARBQ5000					
Regulating port		A		B		P	
Applicable valve		Plug-in	Plug lead	Plug-in	Plug lead	Plug-in	Plug lead
Maximum operating pressure		1.0 MPa					
Set pressure range		0.05 to 0.85 MPa					
Fluid		Air					
Ambient and fluid temperature		-5 to 60 °C (No freezing)					
Port size for connection of pressure gauge		M5 x 0.8					
Weight [kg]		0.79	0.74	0.78	0.73	0.79	0.74
Effective area at supply side [mm ²] S at P ₁ = 0.7 MPa/P ₂ = 0.5 MPa	P → A	33		75		29	
	P → B	64		33		28	
Effective area at exhaust side [mm ²] S at P ₂ = 0.5 MPa	A → EA	36		75		78	
	B → EB	68		38		69	

Note 1) Set the pressure within the operating pressure range of the valve.

Note 2) Operate an interface regulator only by applying pressure from the P port of the base, except when using it as a reverse pressure valve. When using it as a reverse pressure valve, P port regulation is not allowed to use.

Note 3) When using a perfect spacer, assemble a valve, a spacer regulator and a perfect spacer in this order to use it.

Note 4) When using in A port regulation, B port regulation by closed centre, since there is a problem in its operation, please contact SMC.

Note 5) Dust-tight/Water-jet-proof (IP65) is not available with interface regulator.

How to Order

Solenoid valve	Interface regulator	Regulating port
VQ5□0□ (Plug-in type)	ARBQ5000-00-A-1	A
	ARBQ5000-00-B-1	B
	ARBQ5000-00-P-1	P
VQ5□5□ (Plug lead type)	ARBQ5000-00-A-5	A
	ARBQ5000-00-B-5	B
	ARBQ5000-00-P-5	P

Dimensions

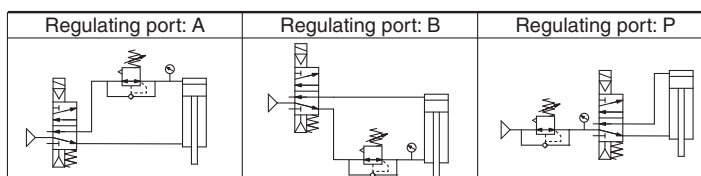
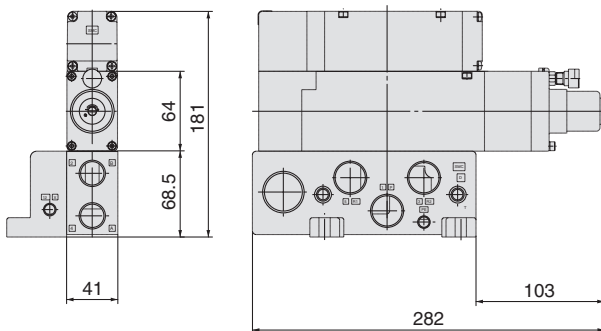

Flow-rate Characteristics

Conditions Inlet pressure: 0.7 MPa

ARBQ5000-00-A (P→A)

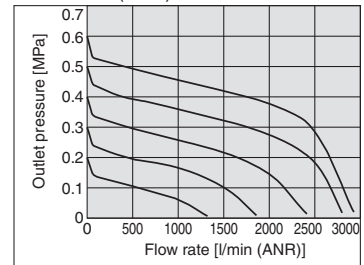

ARBQ5000-00-B (P→B)

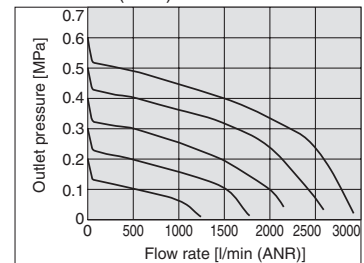

ARBQ5000-00-P (P→A)

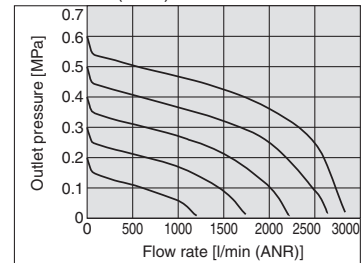

ARBQ5000-00-P (P→B)

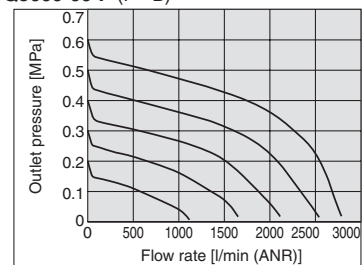

Pressure Characteristics

Conditions

Inlet pressure: 0.7 MPa

Outlet pressure: 0.2 MPa

Flow rate: 20 l/min (ANR)

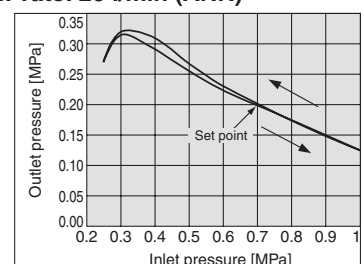

Series VQ5000

Semi-standard Specifications

External Pilot Specifications

- When the supply pressure is:
 - lower than the minimum valve operating pressure of 0.1 to 0.2 MPa, or when it drops below this level,
 - used for reverse pressure (R port pressure) or cylinder pressure (A, B port pressure),
 - used for vacuum specification, it can be used for external pilot specification. Order a valve by adding the external pilot specification [R] to the part number. External pilot is available as standard for manifolds and options.
- Compatibility with universal porting is possible for the single, double and 3-position (excluding double check) types.

Pressure Specifications

Valve construction		Metal seal	Rubber seal
Operating pressure range		-100 kPa to 1.0 MPa	
External pilot pressure range	Single	0.1 to 1.0 MPa	0.2 to 1.0 MPa
	Double		0.15 to 1.0 MPa
	3-position	0.15 to 1.0 MPa	0.2 to 1.0 MPa

How to Order Valves

Sub-plate

Plug-in **VQ5100 [R] - 51 - 04**
 Plug lead **VQ5150 [R] - 5G1 - 04**
 ● External pilot

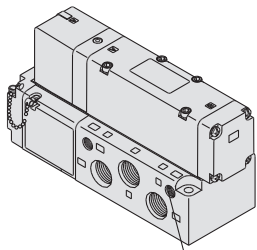

External pilot port
1/8
<Sub-plate>

Manifold

Plug-in **VQ5100 [R] - 51**
 Plug lead **VQ5150 [R] - 5G1**
 ● External pilot

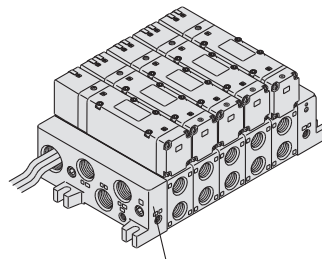

External pilot port
2 x 1/8
<Manifold>

Note) Possible to mix mounting of internal and external pilot

Series VQ5000 Construction

Plug-in Unit

Metal seal type

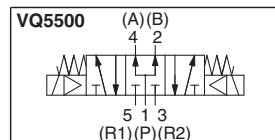
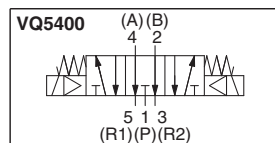
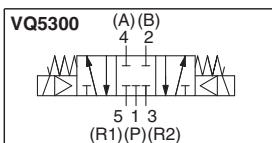
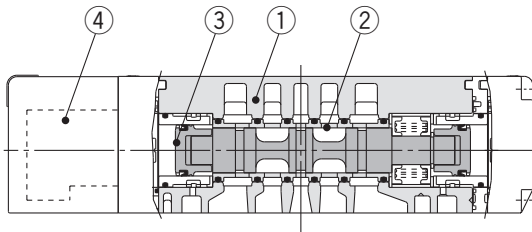
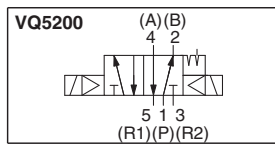
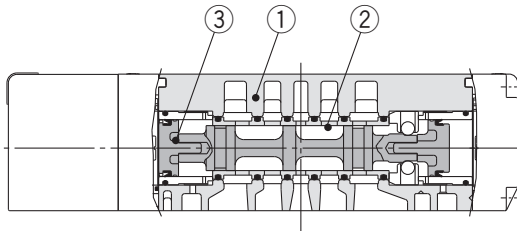
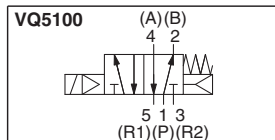
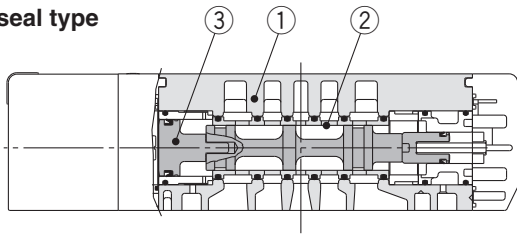

Rubber seal type

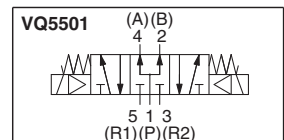
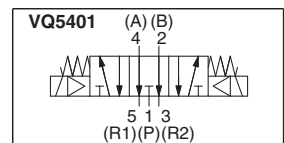
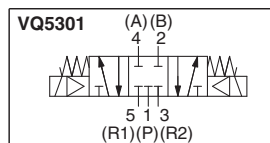
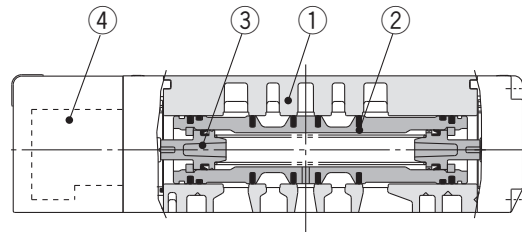
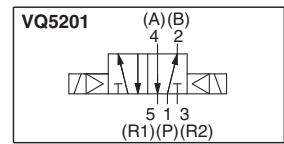
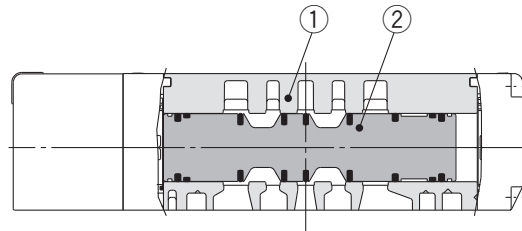
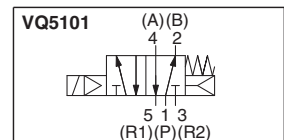
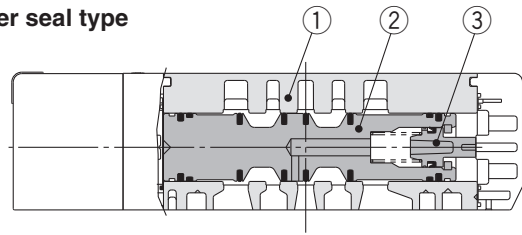

Component Parts

No.	Description	Material	Note
1	Body	Aluminium die-casted	
2	Spool/Sleeve	Stainless steel	
3	Piston	Resin	

Replacement Parts

4	Pilot valve assembly	<p>V118□□□</p> <p>A □ B E</p> <p>□: Coil rated voltage Example) 24 VDC: 5 A: With light (For A side) B: With light (For B side) E: Without light (A/B side common)</p> <p>•Coil type</p> <p>— Standard (0.95 W) Y Low wattage type (0.4 W)</p>	
---	----------------------	------------------------------------------------------------------------------------------------------------------------------------------------------------------------------------------------------------------------------------------------------------------------------------	--

Component Parts

No.	Description	Material	Note
1	Body	Aluminium die-casted	
2	Spool valve	Aluminium, HNBR	
3	Piston	Resin	

Replacement Parts

4	Pilot valve assembly	<p>V118□□□</p> <p>A □ B E</p> <p>□: Coil rated voltage Example) 24 VDC: 5 A: With light (For A side) B: With light (For B side) E: Without light (A/B side common)</p> <p>•Coil type</p> <p>— Standard (0.95 W) Y Low wattage type (0.4 W)</p>	
---	----------------------	------------------------------------------------------------------------------------------------------------------------------------------------------------------------------------------------------------------------------------------------------------------------------------	--

Plug Lead Unit

Metal seal type

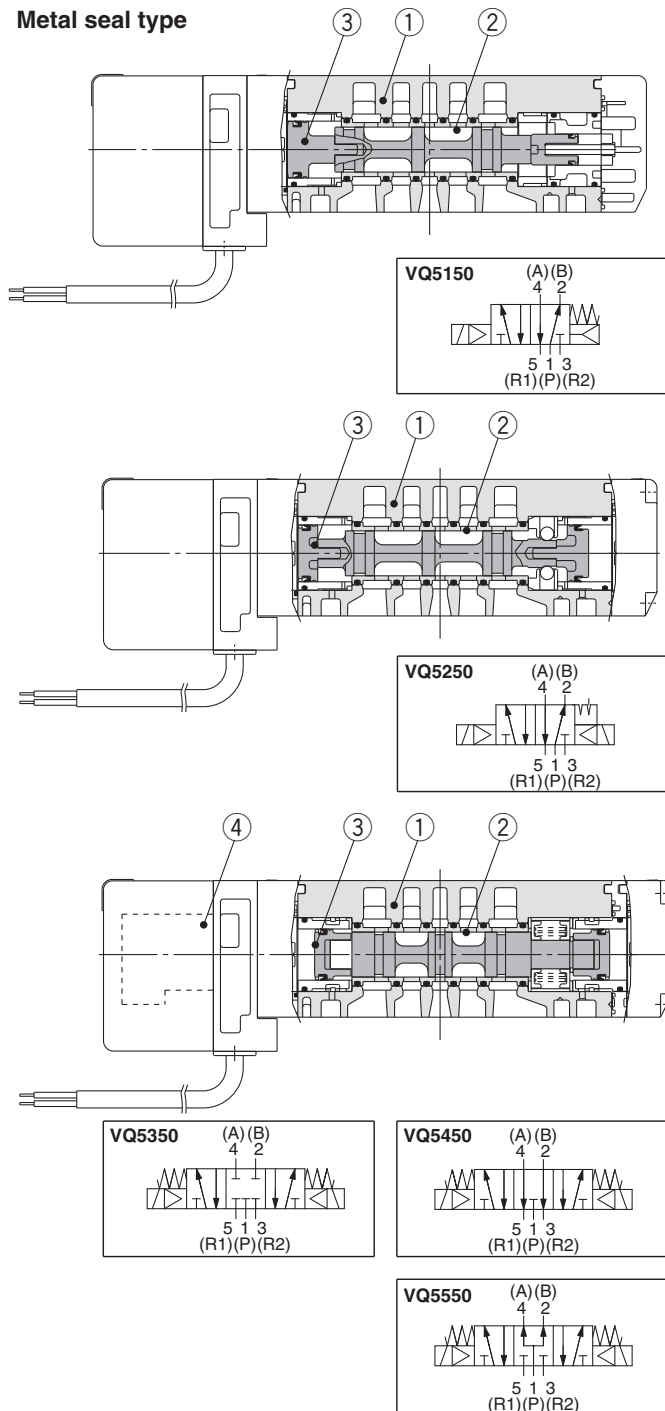

Component Parts

No.	Description	Material	Note
1	Body	Aluminium die-casted	
2	Spool/Sleeve	Stainless steel	
3	Piston	Resin	

Replacement Parts

4	Pilot valve assembly		□: Coil rated voltage Example) 24 VDC: 5 A: With light (For A side) B: With light (For B side) E: Without light (A/B side common)
		•Coil type — Standard (0.95 W) Y Low wattage type (0.4 W)	

Rubber seal type

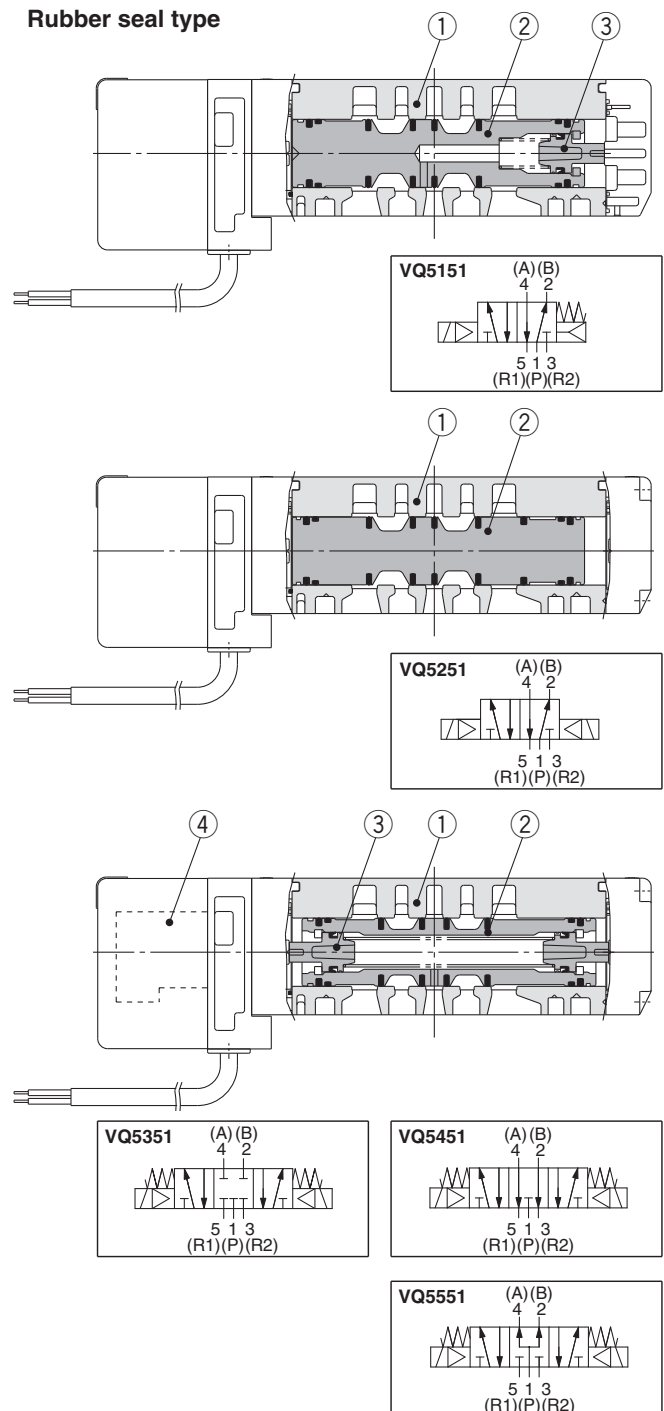

Component Parts

No.	Description	Material	Note
1	Body	Aluminium die-casted	
2	Spool valve	Aluminium, NBR	
3	Piston	Resin	

Replacement Parts

4	Pilot valve assembly		□: Coil rated voltage Example) 24 VDC: 5 A: With light (For A side) B: With light (For B side) E: Without light (A/B side common)
		•Coil type — Standard (0.95 W) Y Low wattage type (0.4 W)	

VQ4000

Manifold Options

Semi-standard Specifications

Manifold with Control Unit

Construction

Exploded View of Manifold

VQ5000

Manifold Options

Semi-standard Specifications

Construction

Exploded View of Manifold

Series VQ5000

Exploded View of Manifold

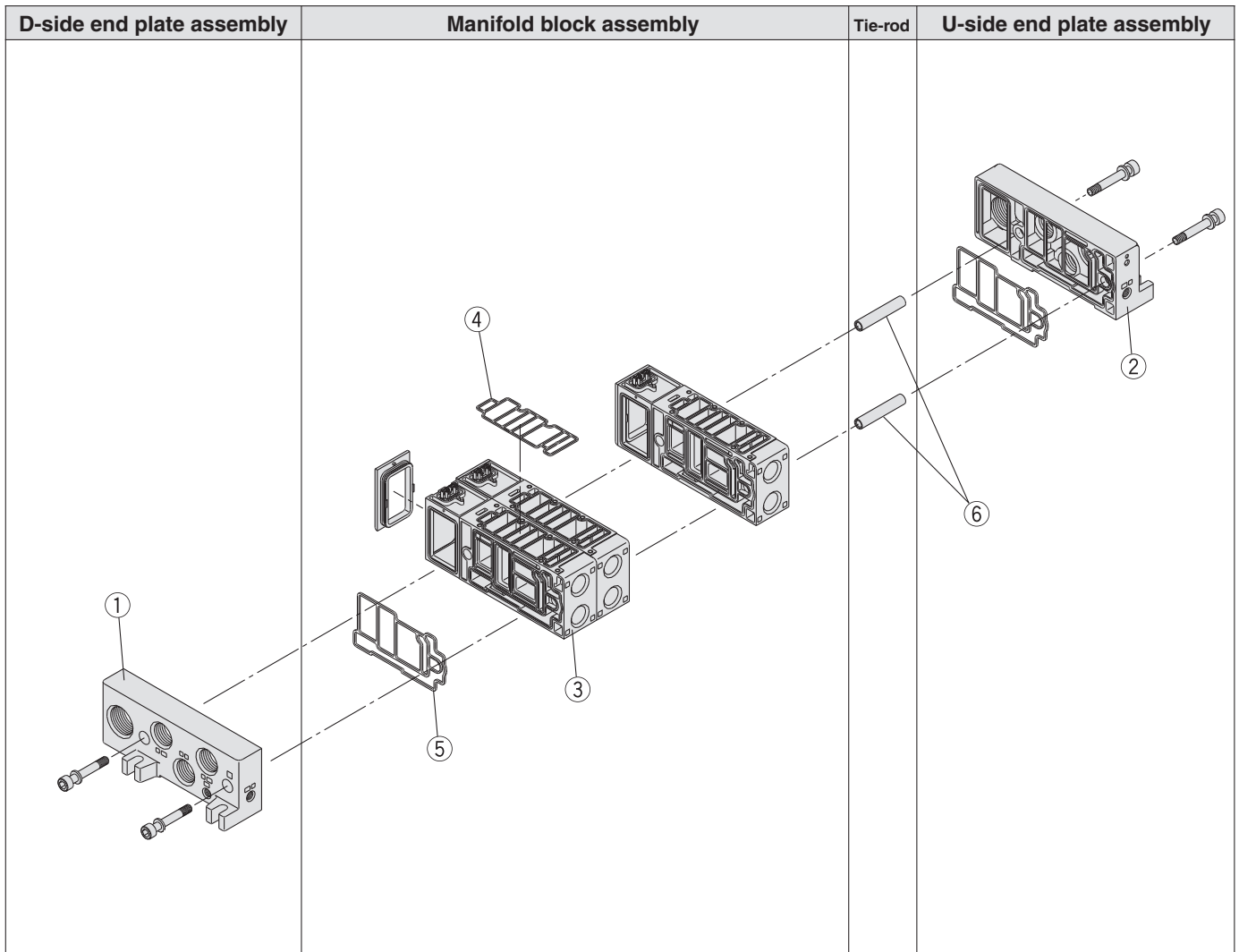

Note) The electrical entry cannot be changed.

Figure shows a plug-in type.

D-Side End Plate Assembly

1. D-side end plate assembly part no. (For F, L, S, T & T1 kits)

VVQ5000 - 3A - 1 [] - [] - [] - []

Thread type

—	Rc
F	G
N	NPT
T	NPTF

Option 1

—	Standard
CD1	Exhaust cleaner mounting Rc 1
CD2	Exhaust cleaner mounting Rc 1 1/2
SD	Direct exhaust with silencer box

Electrical entry

L	F, L, S, T, T1 kit
F ^{Note 1)}	F kit (Connector location on D side)
C	C kit (Plug lead type)

Note 1) D-sub connector assembly for D side: VVQ4000-19A-D is not included. (Order separately)

Option 2

—	Standard
W ^{Note 2)}	IP65 enclosure

Note 2) Drip proof type is not available for F and T1.

U-Side End Plate Assembly

2. U-side end plate assembly part no. (For F, L, S, T & T1 kits)

VVQ5000 - 2A - 1 [] - [] - [] - []

Thread type

—	Rc
F	G
N	NPT
T	NPTF

Option 1

—	Standard
CU1	Exhaust cleaner mounting Rc 1
CU2	Exhaust cleaner mounting Rc 1 1/2
SU	Direct exhaust with silencer box

Electrical entry

L	F, L, S, T, T1 kit
F ^{Note 1)}	F kit (Connector location on U side)
C	C kit (Plug lead type)

Note 1) D-sub connector assembly for U side: VVQ4000-19A-U is not included. (Order separately)

Option 2

—	Standard
W ^{Note 2)}	IP65 enclosure

Note 2) Drip proof type is not available for F and T1.

D-sub connector assembly

D-sub connector assembly

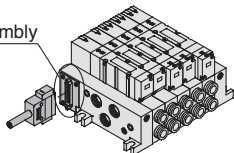

VVQ4000 - 19A - []

Electrical entry

D	D side entry
U	U side entry

Manifold Block Assembly

3. Manifold block assembly part no. (Including ④ and ⑤)

VVQ5000 - 1 [] - [] - [] - [] - []

Type

A	For 1 station
---	---------------

Option

—	Standard
W ^{Note 2)}	IP65 enclosure

Electrical entry

F1	F kit Double wiring
F2	F kit Single wiring
T0	T1 kit (Individual terminal block) Double wiring
T1	T kit (Terminal box) Double wiring
T2	T kit (Terminal box) Single wiring
S1	S kit Double wiring
S2	S kit Single wiring
L0	L0 kit □: Stations (1 to 12)
L1	L1 kit □: Stations (1 to 12)
L2	L2 kit □: Stations (1 to 12)
C	C kit (Plug lead type)

Thread type

—	Rc
F	G
N	NPT
T	NPTF

Port size

03	3/8
04	1/2
B	Bottom ported 1/2

Note 1) Tie-rods (2 pcs.) and lead wire assembly for station addition included.
 Note 2) Drip proof type is not available for F and T1.

Manifold Block Replacement Parts

Replacement Parts

No.	Part no.	Description	Material	Q'ty
④	VVQ5000-80A-1	Gasket	HNBR	10
⑤	VVQ5000-80A-2	Gasket	HNBR	10

Note) Spare parts consist of sets containing 10 pcs. each.

6. Tie-rods part no. (2 pcs.)

VVQ5000 - TR - []

Stations: 02 to 12



Note) When eliminating manifold stations, order this separately. When increasing manifold stations, it is not necessary to order since tie-rods are included in the manifold block assembly.

Housing Assembly and SI Unit

Kit type	Model symbol	Part no.		Description
		For U side mounting	For D side mounting	
	Q	EX124U-SDN1	EX124D-SDN1	DeviceNet®
	R1	EX124U-SCS1	EX124D-SCS1	OMRON Corp.: CompoBus/S (16 output points, 2 power supply systems)
	R2	EX124U-SCS2	EX124D-SCS2	OMRON Corp.: CompoBus/S (8 output points, 2 power supply systems)
	V	EX124U-SMJ1	EX124D-SMJ1	Mitsubishi Electric Corporation: CC-Link System (2 power supply systems)
T (Terminal block box kit)	—	VVQ5000-70A-U (-W)	VVQ5000-70A-D (-W)	—

Series VQ5000

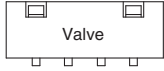
List of Valves, Options, and Mounting Bolts

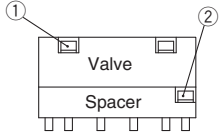
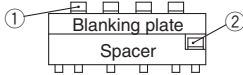
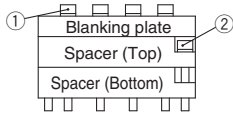
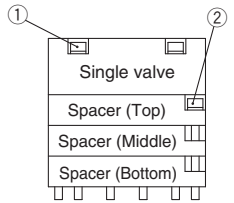
Number of options	Valve and options	Bolt part no. Proper tightening torque: 1 to 1.8 N·m	Qty (pcs.)	Note	Option mounting diagram
0	Single valve	AXT632-25-4 (M4 x 50)	4		
	Blanking plate (VVQ5000-10A- $\frac{1}{5}$)	AXT632-25-8 (M4 x 17)	4	For manifold	
1	Valve + Individual SUP spacer (VVQ5000-P- $\frac{1}{5}$ - $\frac{03}{04}$)	① AXT632-25-5 (M4 x 82)	4	For manifold	
		② AXT632-25-10 (M4 x 34)	2		
	Valve + Individual EXH spacer (VVQ5000-R- $\frac{1}{5}$ - $\frac{03}{04}$)	① AXT632-25-5 (M4 x 82)	4	For manifold	
		② AXT632-25-10 (M4 x 34)	2		
	Valve + Restrictor spacer (VVQ5000-20A- $\frac{1}{5}$)	① AXT632-25-5 (M4 x 82)	4	Not necessary when mounting the sub-plate.	
		② AXT632-25-10 (M4 x 34)	2		
	Valve + Release valve spacer (VVQ5000-24A- $\frac{1}{5}$ D)	① AXT632-25-5 (M4 x 82)	4	For manifold	
		② AXT632-25-10 (M4 x 34)	2		
	Valve + Double check spacer with residual pressure exhaust (VVQ5000-25A- $\frac{1}{5}$)	① AXT632-25-6 (M4 x 114)	4	Not necessary when mounting the sub-plate.	
		② AXT632-66-1 (M4 x 64) ^{Note 2)}	2		
Valve + SUP stop valve spacer (VVQ5000-37A- $\frac{1}{5}$)	① AXT632-25-5 (M4 x 82)	4	Not necessary when mounting the sub-plate.		
	② AXT632-25-10 (M4 x 34)	2			
Valve + Interface regulator (ARBQ5000-00- $\frac{1}{5}$)	① AXT632-25-6 (M4 x 114)	4	Not necessary when mounting the sub-plate.		
	② AXT632-66-1 (M4 x 64)	2			
Blanking plate + SUP stop valve (Top) (Bottom)	① AXT632-25-4 (M4 x 50)	4	For manifold		
	② AXT632-25-10 (M4 x 34)	2			
2	Valve + Individual SUP + Individual EXH (Top) (Bottom) (Bottom) (Top)	① AXT632-25-6 (M4 x 114)	4		For manifold
		② AXT632-25-11 (M4 x 66)	2		
	Valve + Restrictor + Individual SUP or Individual EXH (Top) (Top) (Bottom) (Bottom)	① AXT632-25-6 (M4 x 114)	4		For manifold * The individual EXH cannot be mounted on the top.
		② AXT632-25-11 (M4 x 66)	2		
	Valve + SUP stop valve + Individual SUP, Individual EXH or Restrictor (Top) (Bottom)	① AXT632-25-6 (M4 x 114)	4		For manifold
		② AXT632-25-11 (M4 x 66)	2		
	Valve + Double check spacer with + Individual SUP or residual pressure exhaust Individual EXH (Top) (Bottom)	① AXT632-25-7 (M4 x 146)	4		For manifold
② AXT632-66-2 (M4 x 96) ^{Note 2)}		2			
Valve + Interface regulator + Double check spacer with residual pressure exhaust (Top) (Bottom)	① AXT632-25-14 (M4 x 178)	4	For manifold		
	② AXT632-66-3 (M4 x 128)	2			
Valve + Interface regulator + Individual SUP, Individual EXH or Restrictor (Top) (Bottom)	① AXT632-25-7 (M4 x 146)	4	For manifold * The individual EXH and throttle valve cannot be mounted on the top.		
	② AXT632-66-2 (M4 x 96)	2			
Blanking + SUP stop + Individual plate valve SUP (Top) (Bottom)	① AXT632-25-5 (M4 x 82)	4	For manifold		
	② AXT632-25-11 (M4 x 66)	2			
3	Valve + SUP stop valve (Top) + Individual SUP (Middle, Bottom) + Individual EXH (Middle, Bottom)	① AXT632-25-7 (M4 x 146)	4		For manifold
		② AXT632-25-12 (M4 x 98)	2		
	Valve + Double check spacer with residual pressure exhaust (Top) + Individual SUP (Middle, Bottom) + Individual EXH (Middle, Bottom)	① AXT632-25-14 (M4 x 178)	4		For manifold
② AXT632-66-3 (M4 x 128) ^{Note 2)}		2			
Valve + Spacer (Top): Interface regulator Spacer (Middle): "Individual SUP or Individual EXH"/"Restrictor" Spacer (Bottom): "Restrictor"/"Individual SUP or Individual EXH"	① AXT632-25-14 (M4 x 178)	4	For manifold * The individual EXH and throttle valve cannot be mounted on the top.		
	② AXT632-66-3 (M4 x 128)	2			

Note 1) When the SUP stop valve and individual SUP are mounted, the stop valve is mounted on the top of the individual SUP.

Note 2) Proper tightening torque: 1 to 1.4 N·m



Series VQ4000/5000 Specific Product Precautions 1

Be sure to read this before handling. Refer to the back cover for Safety Instructions. For 3/4/5 Port Solenoid Valve Precautions, refer to “Handling Precautions for SMC Products” and the Operation Manual on the SMC website, <http://www.smc.eu>

Continuous Duty

Warning

When the product is continuously energised for a long period of time (10 minutes or longer), select the low wattage type (DC specification). If anything is unclear, please contact SMC.

Manual Override

Warning

Since connected equipment will operate when the manual override is activated, confirm that conditions are safe prior to activation.

Push type (Tool required)

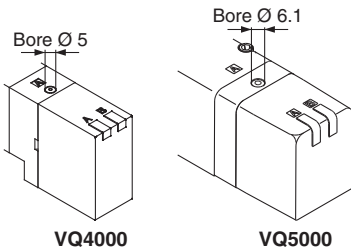

Push down the manual override button with a small screwdriver, etc., until it stops. The manual override will return when released.

Locking type (Tool required)

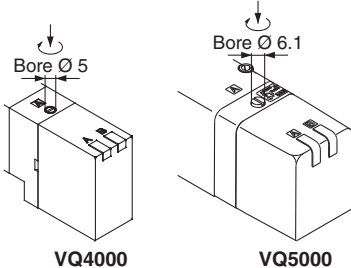

Push down the manual override button with a small flat head screwdriver until it stops, and turn it clockwise 90° to lock it. Turn it counterclockwise to release it.

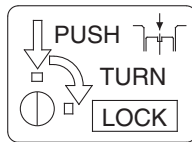

Locking type (Manual)

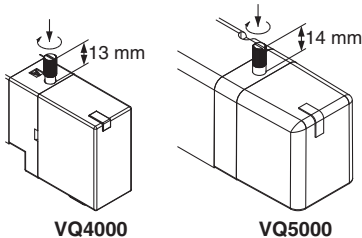

Push down the manual override button with a small flat head screwdriver or with your fingers until it stops. Turn it clockwise by 90° to lock it. Turn it counterclockwise to release it.

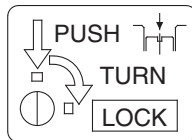

Caution

Do not apply excessive torque when turning the locking type manual override. (0.1 N·m or less)

Valve Mounting

Caution

After confirming that the gasket is installed correctly, securely tighten the mounting screws according to the tightening torque shown below.

VQ4000

Proper tightening torque [N·m]
0.8 to 1.2

VQ5000

Proper tightening torque [N·m]
1 to 1.8

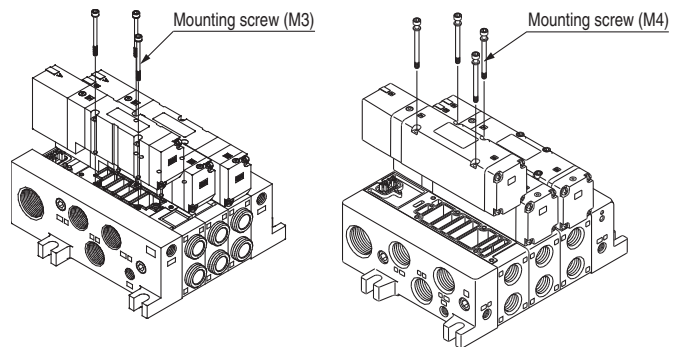

Replacement of One-touch Fittings/VQ4000

Caution

Cylinder port fittings are available in cassette type and can be replaced easily. Fittings are secured with a retaining clip that is inserted from the top side of the valve. After removing the valve, remove the clip with a flat head screwdriver to replace the fittings. To mount a fitting, insert the fitting assembly until it stops and reinsert the retaining clip to its designated position.

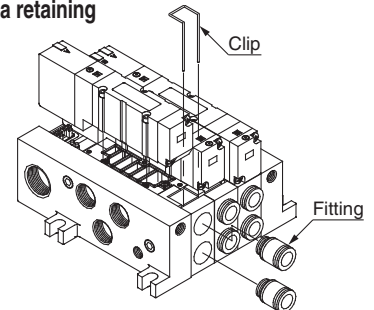

Lead Wire Connection

Caution

Plug-in sub-plate (With terminal block)

- If the junction cover ① of the sub-plate is removed, you can see the plug-in type terminal block ② mounted inside the sub-plate.
- The terminal block is marked as follows. Connect wiring to each of the power supply terminals.

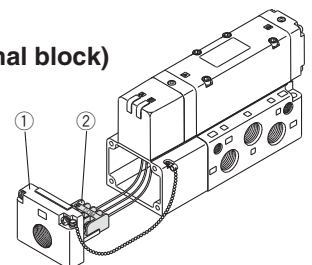

Terminal block marking	A	COM	B	⊖
Model VQ ₅ ⁴ 10 ₁ ⁰	A side	COM	—	—
VQ ₅ ⁴ 20 ₁ ⁰	A side	COM	B side	—
VQ ₅ ⁴ ₅ ³ 0 ₁ ⁰	A side	COM	B side	—

Note 1) There is no polarity. It can also be used as -COM.
Note 2) The sub-plate is double wired even for the VQ₅⁴10₁⁰.

- Applicable terminal: 1.25-3s, 1.25Y-3, 1.25Y-3N, 1.25Y-3.5



Series VQ4000/5000 Specific Product Precautions 2

Be sure to read this before handling. Refer to the back cover for Safety Instructions. For 3/4/5 Port Solenoid Valve Precautions, refer to “Handling Precautions for SMC Products” and the Operation Manual on the SMC website, <http://www.smc.eu>

Lead Wire Connection

Caution

Plug lead: Grommet type

Make connections to each corresponding wire.

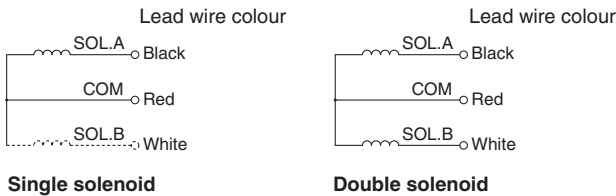

	Single solenoid	Double solenoid
Standard		
IP65 enclosure		

Note) There is no polarity. It can also be used as -COM.

Installation and Removal of Light Cover

Caution

Installation/Removal of light cover (VQ4000)

• Removal

Open the cover by inserting a small flat head screwdriver into the slot on the side of the pilot assembly (see drawing below), lift the cover out about 1 mm and then pull off. If it is pulled off at an angle, the pilot valve may be damaged or the protective O-ring may be scratched.

• Installation

Place the cover straight over the pilot assembly so that the pilot valve is not touched, and push it until the cover hook locks without twisting the protective O-ring. (When pushed in, the hook opens and locks automatically.)

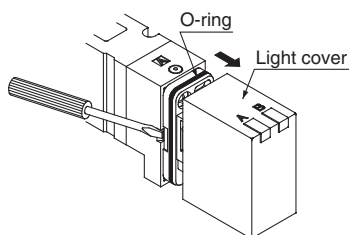

Installation and Removal of Light Cover

Caution

Installation/Removal of light cover (VQ5000)

• Removal

To remove the pilot cover pull it straight off. If it is pulled off at an angle, the pilot valve may be damaged or the protective O-ring may be scratched.

• Installation

Place the cover straight over the pilot assembly so that the pilot valve is not touched, and push it until the cover hook locks without twisting the protective O-ring. (When pushed in, the hook opens and locks automatically.)

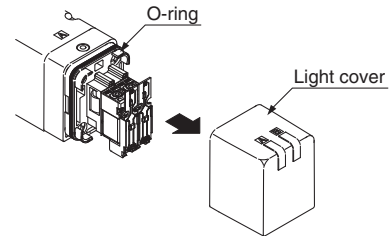

Replacement of Pilot Valve

Caution

• Removal

Remove the mounting screw that holds the pilot valve using a small screwdriver.

• Installation

After confirming the gasket is correctly placed under the valve, securely tighten the bolts with the proper torque shown in the table below.

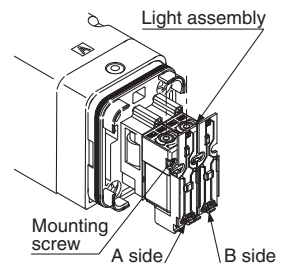

Proper tightening torque [N·m]

0.1 to 0.13

Note) The light circuit boards: A side is red and the B side is green. It must be mounted on the pilot valve in accordance with the mounting indicators.

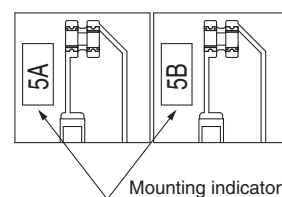



Series VQ4000/5000

Specific Product Precautions 3

Be sure to read this before handling. Refer to the back cover for Safety Instructions. For 3/4/5 Port Solenoid Valve Precautions, refer to “Handling Precautions for SMC Products” and the Operation Manual on the SMC website, <http://www.smc.eu>

Plug Lead Type

Attaching and detaching connectors

- To attach a connector, hold the lever and connector unit between your fingers and insert straight onto the pins of the solenoid valve so that the lever's pawl is pushed into the groove and locks.
- To detach a connector, remove the pawl from the groove by pushing the lever downward with your thumb, and pull the connector straight out.

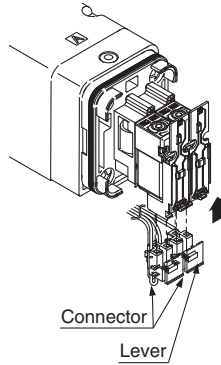

Note) Do not pull on the lead wires with excessive force. This can cause faulty and/or broken contacts.

Enclosure IP65

Caution

Wires, cables, connectors, etc. used for models conforming to IP 65 should also have enclosures equivalent to or stricter rating than IP65.

How to Calculate the Flow Rate

For obtaining the flow rate, consult SMC.

Internal Wiring Specifications

Caution

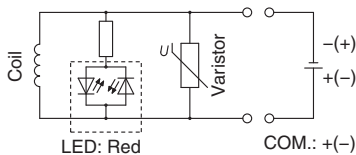

DC: Single

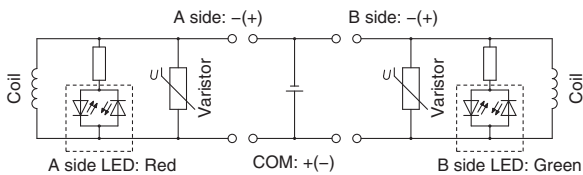

DC: Double



Note) For DC, coil surge voltage generated when OFF is about – 60 V. Please contact SMC separately for further suppression of the coil surge voltage.

Trademark

DeviceNet® is a trademark of ODVA.

Safety Instructions

These safety instructions are intended to prevent hazardous situations and/or equipment damage. These instructions indicate the level of potential hazard with the labels of “Caution,” “Warning” or “Danger.” They are all important notes for safety and must be followed in addition to International Standards (ISO/IEC)¹⁾, and other safety regulations.

-  **Caution:** **Caution** indicates a hazard with a low level of risk which, if not avoided, could result in minor or moderate injury.
-  **Warning:** **Warning** indicates a hazard with a medium level of risk which, if not avoided, could result in death or serious injury.
-  **Danger:** **Danger** indicates a hazard with a high level of risk which, if not avoided, will result in death or serious injury.

- 1) ISO 4414: Pneumatic fluid power – General rules relating to systems.
ISO 4413: Hydraulic fluid power – General rules relating to systems.
IEC 60204-1: Safety of machinery – Electrical equipment of machines.
(Part 1: General requirements)
- ISO 10218-1: Manipulating industrial robots - Safety.
etc.

Warning

1. The compatibility of the product is the responsibility of the person who designs the equipment or decides its specifications.

Since the product specified here is used under various operating conditions, its compatibility with specific equipment must be decided by the person who designs the equipment or decides its specifications based on necessary analysis and test results. The expected performance and safety assurance of the equipment will be the responsibility of the person who has determined its compatibility with the product. This person should also continuously review all specifications of the product referring to its latest catalogue information, with a view to giving due consideration to any possibility of equipment failure when configuring the equipment.

2. Only personnel with appropriate training should operate machinery and equipment.

The product specified here may become unsafe if handled incorrectly. The assembly, operation and maintenance of machines or equipment including our products must be performed by an operator who is appropriately trained and experienced.

3. Do not service or attempt to remove product and machinery/equipment until safety is confirmed.

1. The inspection and maintenance of machinery/equipment should only be performed after measures to prevent falling or runaway of the driven objects have been confirmed.
2. When the product is to be removed, confirm that the safety measures as mentioned above are implemented and the power from any appropriate source is cut, and read and understand the specific product precautions of all relevant products carefully.
3. Before machinery/equipment is restarted, take measures to prevent unexpected operation and malfunction.

4. Contact SMC beforehand and take special consideration of safety measures if the product is to be used in any of the following conditions.

1. Conditions and environments outside of the given specifications, or use outdoors or in a place exposed to direct sunlight.
2. Installation on equipment in conjunction with atomic energy, railways, air navigation, space, shipping, vehicles, military, medical treatment, combustion and recreation, or equipment in contact with food and beverages, emergency stop circuits, clutch and brake circuits in press applications, safety equipment or other applications unsuitable for the standard specifications described in the product catalogue.
3. An application which could have negative effects on people, property, or animals requiring special safety analysis.
4. Use in an interlock circuit, which requires the provision of double interlock for possible failure by using a mechanical protective function, and periodical checks to confirm proper operation.

Caution

1. The product is provided for use in manufacturing industries.

The product herein described is basically provided for peaceful use in manufacturing industries.
If considering using the product in other industries, consult SMC beforehand and exchange specifications or a contract if necessary.
If anything is unclear, contact your nearest sales branch.

Limited warranty and Disclaimer/Compliance Requirements

The product used is subject to the following “Limited warranty and Disclaimer” and “Compliance Requirements”. Read and accept them before using the product.

Limited warranty and Disclaimer

1. The warranty period of the product is 1 year in service or 1.5 years after the product is delivered, whichever is first.²⁾ Also, the product may have specified durability, running distance or replacement parts. Please consult your nearest sales branch.
 2. For any failure or damage reported within the warranty period which is clearly our responsibility, a replacement product or necessary parts will be provided. This limited warranty applies only to our product independently, and not to any other damage incurred due to the failure of the product.
 3. Prior to using SMC products, please read and understand the warranty terms and disclaimers noted in the specified catalogue for the particular products.
- 2) Vacuum pads are excluded from this 1 year warranty.
A vacuum pad is a consumable part, so it is warranted for a year after it is delivered. Also, even within the warranty period, the wear of a product due to the use of the vacuum pad or failure due to the deterioration of rubber material are not covered by the limited warranty.

Compliance Requirements

1. The use of SMC products with production equipment for the manufacture of weapons of mass destruction (WMD) or any other weapon is strictly prohibited.
2. The exports of SMC products or technology from one country to another are governed by the relevant security laws and regulations of the countries involved in the transaction. Prior to the shipment of a SMC product to another country, assure that all local rules governing that export are known and followed.

Caution

SMC products are not intended for use as instruments for legal metrology.

Measurement instruments that SMC manufactures or sells have not been qualified by type approval tests relevant to the metrology (measurement) laws of each country.
Therefore, SMC products cannot be used for business or certification ordained by the metrology (measurement) laws of each country.

Safety Instructions

Be sure to read “Handling Precautions for SMC Products” (M-E03-3) before using.

SMC Corporation (Europe)

Austria	+43 (0)2262622800	www.smc.at	office@smc.at	Lithuania	+370 5 2308118	www.smclt.lt	info@smclt.lt
Belgium	+32 (0)33551464	www.smc.be	info@smc.be	Netherlands	+31 (0)205318888	www.smc.nl	info@smc.nl
Bulgaria	+359 (0)2807670	www.smc.bg	office@smc.bg	Norway	+47 67129020	www.smc-norge.no	post@smc-norge.no
Croatia	+385 (0)13707288	www.smc.hr	office@smc.hr	Poland	+48 222119600	www.smc.pl	sales@smc.pl
Czech Republic	+420 541424611	www.smc.cz	office@smc.cz	Portugal	+351 214724500	www.smc.eu	apoioclientept@smc.smces.es
Denmark	+45 70252900	www.smcdk.com	smc@smcdk.com	Romania	+40 213205111	www.smcromania.ro	smcromania@smcromania.ro
Estonia	+372 651 0370	www.smcee.ee	info@smcee.ee	Russia	+7 (812)3036600	www.smc.eu	sales@smcru.com
Finland	+358 207513513	www.smc.fi	smcfi@smc.fi	Slovakia	+421 (0)413213212	www.smc.sk	office@smc.sk
France	+33 (0)164761000	www.smc-france.fr	supportclient@smc-france.fr	Slovenia	+386 (0)73885412	www.smc.si	office@smc.si
Germany	+49 (0)61034020	www.smc.de	info@smc.de	Spain	+34 945184100	www.smc.eu	post@smc.smces.es
Greece	+30 210 2717265	www.smchellas.gr	sales@smchellas.gr	Sweden	+46 (0)86031240	www.smc.nu	smc@smc.nu
Hungary	+36 23513000	www.smc.hu	office@smc.hu	Switzerland	+41 (0)523963131	www.smc.ch	info@smc.ch
Ireland	+353 (0)14039000	www.smcautomation.ie	sales@smcautomation.ie	Turkey	+90 212 489 0 440	www.smcturkey.com.tr	info@smcturkey.com.tr
Italy	+39 03990691	www.smcitalia.it	mailbox@smcitalia.it	UK	+44 (0)845 121 5122	www.smc.uk	sales@smc.uk
Latvia	+371 67817700	www.smc.lv	info@smc.lv				
				South Africa	+27 10 900 1233	www.smcza.co.za	zasales@smcza.co.za