

Series VQC1000

Base Mounted Plug-in Unit

How to Order Manifold

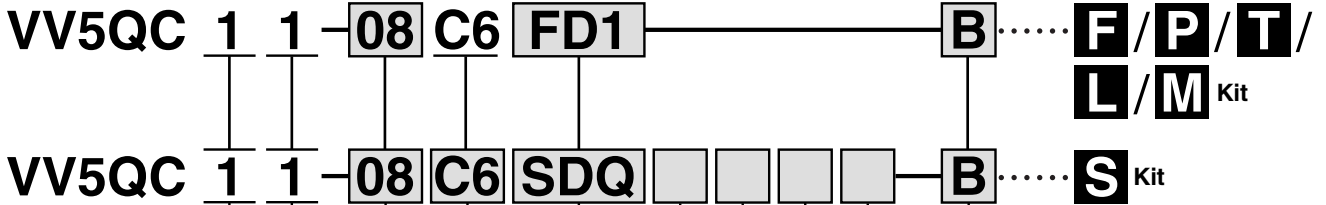

Series

1	VQC1000
---	---------

Manifold model

1	Plug-in unit
---	--------------

Stations

01	1 station
⋮	⋮

The maximum number of stations differs depending on the electrical entry.

Cylinder port size

C3	With ø3.2 One-touch fitting
C4	With ø4 One-touch fitting
C6	With ø6 One-touch fitting
M5	M5 thread
CM	Mixed sizes and with port plug
L3	Top ported elbow With ø3.2 One-touch fitting
L4	Top ported elbow With ø4 One-touch fitting
L6	Top ported elbow With ø6 One-touch fitting
L5	M5 thread
B3	Bottom ported elbow With ø3.2 One-touch fitting
B4	Bottom ported elbow With ø4 One-touch fitting
B6	Bottom ported elbow With ø6 One-touch fitting
B5	M5 thread
LM	Elbow port, mixed sizes

Note 1) Indicate the size in the specification sheet in the case of "CM" and "LM".

Note 2) Symbols for inch sizes areas follows:
<For One-touch fittings>

- N1: ø1/8"
- N3: ø5/32"
- N7: ø1/4"
- NM: Mixed

The top ported elbow is LN□ and the bottom ported elbow is BN□.

Kit designation/Electrical entry/Cable length
 (Refer to page 2-2-12 for detailed information on kits.)

Option

Nil	None
B	All stations with back pressure check valve ^{Note 1)}
D	With DIN rail (Rail length: Standard)
D□	With DIN rail (Rail length: Special) ^{Note 2)}
K	Special wiring specifications ^{Note 3)} (Except double wiring)
N	With name plate
R	External pilot ^{Note 4)}
S	Direct exhaust with built-in silencer ^{Note 5)}

* When specifying more than one option, enter symbols in alphabetical order.
 Example: -BRS

Note 1) When using the back pressure check valve for the necessary stations only, enter the back pressure check valve part no. and indicate the number of manifold stations on the specification sheet.

Note 2) For special DIN rail length, indicate "D□". (Enter the number of stations inside □.)

Example: -D08
 In this case, stations will be mounted on a DIN rail for 8 stations regardless of the actual number of manifold stations.

The specified number of stations must be larger than the number of stations on the manifold.

Indicate "-D0" for the option without DIN rail.

Note 3) Be sure to indicate the wiring specifications on the specification sheet.

Note 4) For external pilot option, "-R", indicate the external pilot specification "R" for the applicable valves as well.

Note 5) The built-in silencer type does not satisfy the IP67 standard.

Input block COM.
 (Fill out for I/O unit only)

Nil	PNP (+) or without SI unit/input block
N	NPN (-)

Input block type
 (Fill out for I/O unit only)

Nil	Without input block
1	M12, 2 inputs
2	M12, 4 inputs
3	M8, 4 inputs (3 pins)

Number of input blocks
 (Fill out for I/O unit only)

Nil	Without SI unit/input block
0	Without input block
1	With 1 input block
⋮	⋮
8	With 8 input blocks

SI unit COM

SI unit COM	EX250					EX500				EX126
	DeviceNet	PROFIBUS-DP	CC-LINK	AS-i	CANopen	DeviceNet	PROFIBUS-DP	CC-LINK	Remote I/O	CC-LINK
Nil +COM	—	—	○	—	—	○	○	○	○	○
N -COM	○	○	—	○	○	○	○	○	○	—

Note) Leave the box blank for the SI unit COM without SI unit (SD0).

- VQC
- SQ
- VQ0
- VQ4
- VQ5
- VQZ
- VQD

How to Order Valves

VQC 1 1 0 0 **5**

Series
1 VQC1000

Type of actuation

1	2 position single (A)(B) 4 2 5 1 3 (R1)(P)(R2)	A Note)	4 position dual 3 port valve (A) (A) (B) 4 2 5 1 3 (R1) 1 (R2) N.C (P) N.C
2	2 position double (metal) (A)(B) 4 2 5 1 3 (R1)(P)(R2)	B Note)	4 position dual 3 port valve (B) (A) (B) 4 2 5 1 3 (R1) 1 (R2) N.O (P) N.O
	2 position double (rubber) (A)(B) 4 2 5 1 3 (R1)(P)(R2)		C Note)
3	3 position closed center (A)(B) 4 2 5 1 3 (R1)(P)(R2)	Note) For rubber seal type only.	
	3 position exhaust center (A)(B) 4 2 5 1 3 (R1)(P)(R2)		
	3 position pressure center (A)(B) 4 2 5 1 3 (R1)(P)(R2)		

Seal type

0	Metal seal
1	Rubber seal

Light/Surge voltage suppressor

Nil	With
E	Without Note)

Note) Not applicable to S kit.

Coil voltage

5	24 VDC Note)
6	12 VDC

Note) S kit is only available for 24 VDC.

Function

Nil	Standard type (1 W)
K Note 1)	High pressure type (1.0 MPa)
N	Negative COM
R Note 2)	External pilot
Y	Low wattage type (0.5 W)

* When specifying more than one option, enter symbols in alphabetical order.
Note 1) For metal seal type only.
Note 2) Not applicable for dual 3 port valve.

Manual override

Nil: Non-locking push type (Slotted)

B: Locking type (Slotted)

C: Locking type (Manual)

D: Slide locking type (Manual)

Kit Designation/Electrical Entry/Cable Length

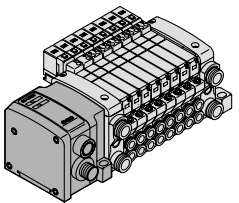
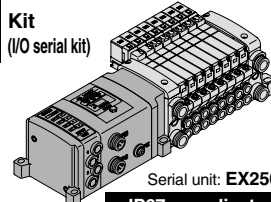
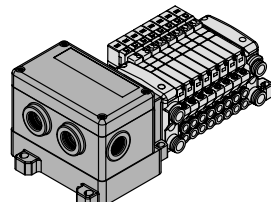
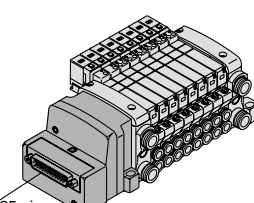
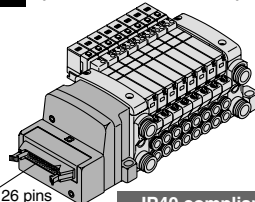
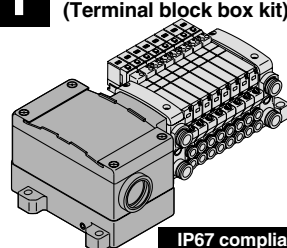
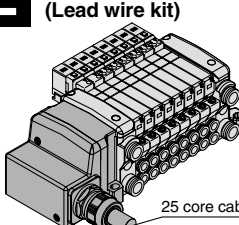
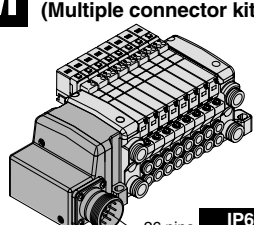
<p>S Kit (Decentralized wiring type serial kit)</p>  <p>Serial unit: EX500 IP67 compliant</p> <p>Note) A separate gateway unit and communication cable are required.</p> <table border="1"> <tr> <td>SD0 Serial kit without SI unit</td> <td></td> </tr> <tr> <td>SDA1 Serial kit for Remote I/O</td> <td>1 to 8 stations (16 stations)</td> </tr> <tr> <td>SDA2 Serial kit for DeviceNet/PROFIBUS-DP/CC-LINK</td> <td></td> </tr> </table>	SD0 Serial kit without SI unit		SDA1 Serial kit for Remote I/O	1 to 8 stations (16 stations)	SDA2 Serial kit for DeviceNet/PROFIBUS-DP/CC-LINK		<p>S Kit (I/O serial kit)</p>  <p>Serial unit: EX250 IP67 compliant</p> <table border="1"> <tr> <td>SD0 Serial kit without SI unit</td> <td></td> </tr> <tr> <td>SDY Serial kit for CANopen</td> <td></td> </tr> <tr> <td>SDQ Serial kit for DeviceNet</td> <td>1 to 12 stations (24 stations)</td> </tr> <tr> <td>SDN Serial kit for PROFIBUS-DP</td> <td></td> </tr> <tr> <td>SDV Serial kit for CC-LINK</td> <td></td> </tr> <tr> <td>SDTA AS-; 8 in/out, 31 slave modes, 2 power supply systems</td> <td>1 to 4 stations (8 stations)</td> </tr> <tr> <td>SDTB AS-; 4 in/out, 31 slave modes, 2 power supply systems</td> <td>1 to 2 stations (4 stations)</td> </tr> <tr> <td>SDTC AS-; 8 in/out, 31 slave modes, 1 power supply systems</td> <td>1 to 4 stations (8 stations)</td> </tr> <tr> <td>SDTD AS-; 4 in/out, 31 slave modes, 1 power supply systems</td> <td>1 to 2 stations (4 stations)</td> </tr> </table>	SD0 Serial kit without SI unit		SDY Serial kit for CANopen		SDQ Serial kit for DeviceNet	1 to 12 stations (24 stations)	SDN Serial kit for PROFIBUS-DP		SDV Serial kit for CC-LINK		SDTA AS-; 8 in/out, 31 slave modes, 2 power supply systems	1 to 4 stations (8 stations)	SDTB AS-; 4 in/out, 31 slave modes, 2 power supply systems	1 to 2 stations (4 stations)	SDTC AS-; 8 in/out, 31 slave modes, 1 power supply systems	1 to 4 stations (8 stations)	SDTD AS-; 4 in/out, 31 slave modes, 1 power supply systems	1 to 2 stations (4 stations)	<p>S Kit (Serial output kit)</p>  <p>Serial unit: EX126 IP67 compliant</p> <table border="1"> <tr> <td>SDVB Serial kit for CC-LINK</td> <td>1 to 8 stations (16 stations)</td> </tr> </table>	SDVB Serial kit for CC-LINK	1 to 8 stations (16 stations)	<p>F Kit (D-sub connector kit)</p>  <p>25 pins</p> <p>IP40 compliant</p> <table border="1"> <tr> <td>FD0 D-sub connector kit (25P) without cable</td> <td></td> </tr> <tr> <td>FD1 D-sub connector kit (25P) with 1.5 m cable</td> <td>1 to 12 stations (24 stations)</td> </tr> <tr> <td>FD2 D-sub connector kit (25P) with 3.0 m cable</td> <td></td> </tr> <tr> <td>FD3 D-sub connector kit (25P) with 5.0 m cable</td> <td></td> </tr> </table>	FD0 D-sub connector kit (25P) without cable		FD1 D-sub connector kit (25P) with 1.5 m cable	1 to 12 stations (24 stations)	FD2 D-sub connector kit (25P) with 3.0 m cable		FD3 D-sub connector kit (25P) with 5.0 m cable	
SD0 Serial kit without SI unit																																					
SDA1 Serial kit for Remote I/O	1 to 8 stations (16 stations)																																				
SDA2 Serial kit for DeviceNet/PROFIBUS-DP/CC-LINK																																					
SD0 Serial kit without SI unit																																					
SDY Serial kit for CANopen																																					
SDQ Serial kit for DeviceNet	1 to 12 stations (24 stations)																																				
SDN Serial kit for PROFIBUS-DP																																					
SDV Serial kit for CC-LINK																																					
SDTA AS-; 8 in/out, 31 slave modes, 2 power supply systems	1 to 4 stations (8 stations)																																				
SDTB AS-; 4 in/out, 31 slave modes, 2 power supply systems	1 to 2 stations (4 stations)																																				
SDTC AS-; 8 in/out, 31 slave modes, 1 power supply systems	1 to 4 stations (8 stations)																																				
SDTD AS-; 4 in/out, 31 slave modes, 1 power supply systems	1 to 2 stations (4 stations)																																				
SDVB Serial kit for CC-LINK	1 to 8 stations (16 stations)																																				
FD0 D-sub connector kit (25P) without cable																																					
FD1 D-sub connector kit (25P) with 1.5 m cable	1 to 12 stations (24 stations)																																				
FD2 D-sub connector kit (25P) with 3.0 m cable																																					
FD3 D-sub connector kit (25P) with 5.0 m cable																																					
<p>P Kit (Flat ribbon cable kit)</p>  <p>26 pins 20 pins</p> <p>IP40 compliant</p> <p>Note) For a 20P flat ribbon cable, the cable assembly must be ordered separately.</p> <table border="1"> <tr> <td>PD0 Flat ribbon cable kit (26P) without cable</td> <td></td> </tr> <tr> <td>PD1 Flat ribbon cable kit (26P) with 1.5 m cable</td> <td>1 to 12 stations (24 stations)</td> </tr> <tr> <td>PD2 Flat ribbon cable kit (26P) with 3.0 m cable</td> <td></td> </tr> <tr> <td>PD3 Flat ribbon cable kit (26P) with 5.0 m cable</td> <td></td> </tr> <tr> <td>PDC Flat ribbon cable kit (20P) without cable</td> <td>1 to 9 stations (18 stations)</td> </tr> </table>	PD0 Flat ribbon cable kit (26P) without cable		PD1 Flat ribbon cable kit (26P) with 1.5 m cable	1 to 12 stations (24 stations)	PD2 Flat ribbon cable kit (26P) with 3.0 m cable		PD3 Flat ribbon cable kit (26P) with 5.0 m cable		PDC Flat ribbon cable kit (20P) without cable	1 to 9 stations (18 stations)	<p>T Kit (Terminal block box kit)</p>  <p>IP67 compliant</p> <table border="1"> <tr> <td>TD0 Terminal block box kit</td> <td>1 to 10 stations (20 stations)</td> </tr> </table>	TD0 Terminal block box kit	1 to 10 stations (20 stations)	<p>L Kit (Lead wire kit)</p>  <p>25 core cable</p> <p>IP67 compliant</p> <table border="1"> <tr> <td>LD0 Lead wire kit (25 core) 0.6 m lead wire</td> <td>1 to 12 stations (24 stations)</td> </tr> <tr> <td>LD1 Lead wire kit (25 core) 1.5 m lead wire</td> <td></td> </tr> <tr> <td>LD2 Lead wire kit (25 core) 3.0 m lead wire</td> <td></td> </tr> </table>	LD0 Lead wire kit (25 core) 0.6 m lead wire	1 to 12 stations (24 stations)	LD1 Lead wire kit (25 core) 1.5 m lead wire		LD2 Lead wire kit (25 core) 3.0 m lead wire		<p>M Kit (Multiple connector kit)</p>  <p>26 pins</p> <p>IP67 compliant</p> <table border="1"> <tr> <td>MD0 Multiple connector kit (26P) without cable</td> <td></td> </tr> <tr> <td>MD1 Multiple connector kit (26P) with 1.5 m cable</td> <td>1 to 12 stations (24 stations)</td> </tr> <tr> <td>MD2 Multiple connector kit (26P) with 3.0 m cable</td> <td></td> </tr> <tr> <td>MD3 Multiple connector kit (26P) with 5.0 m cable</td> <td></td> </tr> </table>	MD0 Multiple connector kit (26P) without cable		MD1 Multiple connector kit (26P) with 1.5 m cable	1 to 12 stations (24 stations)	MD2 Multiple connector kit (26P) with 3.0 m cable		MD3 Multiple connector kit (26P) with 5.0 m cable									
PD0 Flat ribbon cable kit (26P) without cable																																					
PD1 Flat ribbon cable kit (26P) with 1.5 m cable	1 to 12 stations (24 stations)																																				
PD2 Flat ribbon cable kit (26P) with 3.0 m cable																																					
PD3 Flat ribbon cable kit (26P) with 5.0 m cable																																					
PDC Flat ribbon cable kit (20P) without cable	1 to 9 stations (18 stations)																																				
TD0 Terminal block box kit	1 to 10 stations (20 stations)																																				
LD0 Lead wire kit (25 core) 0.6 m lead wire	1 to 12 stations (24 stations)																																				
LD1 Lead wire kit (25 core) 1.5 m lead wire																																					
LD2 Lead wire kit (25 core) 3.0 m lead wire																																					
MD0 Multiple connector kit (26P) without cable																																					
MD1 Multiple connector kit (26P) with 1.5 m cable	1 to 12 stations (24 stations)																																				
MD2 Multiple connector kit (26P) with 3.0 m cable																																					
MD3 Multiple connector kit (26P) with 5.0 m cable																																					

Manifold Option

Blanking plate assembly
VVQ1000-10A-1

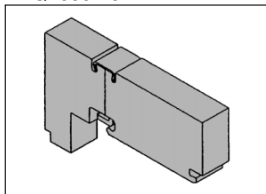

SUP block plate
VVQ1000-16A

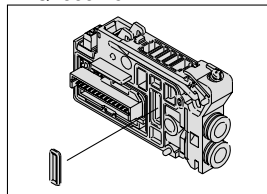

Perfect block
VVQ1000-FPG-□□

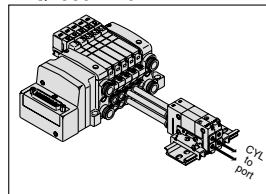

Dual flow fitting assembly
VVQ1000-52A-C8

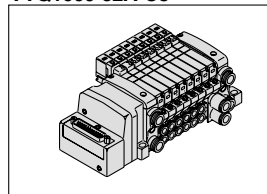

Blanking plate with connector
VVQ1000-1C□□-□

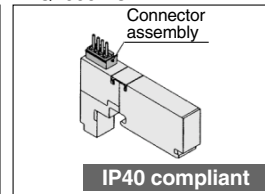

Individual SUP spacer
VVQ1000-P-1-C6

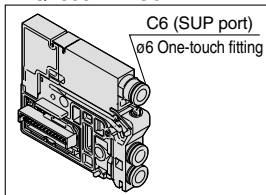

EXH block plate assembly
VVQC1000-19A-S-□□□□□□□□

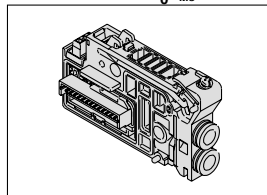

Elbow fitting assembly
VVQ1000-F-L□

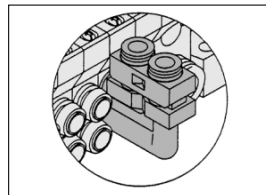

Port plug
VVQ0000-58A

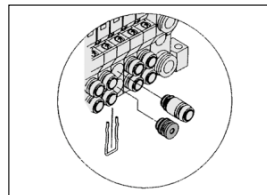

Electrical wiring specifications [-K]

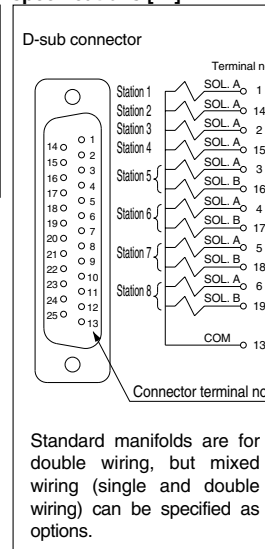

Individual EXH spacer
VVQ1000-R-1-C6

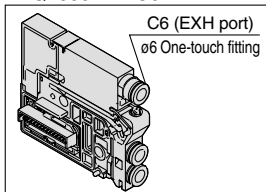

DIN rail mounting bracket [-D]
VVQ1000-57A
for (F, L, M, P, S (EX500) kit)

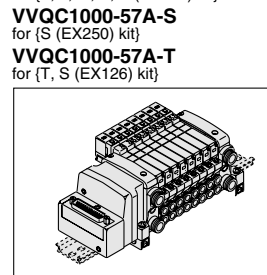

Silencer (For EXH port)
AN200-KM8
AN203-KM8

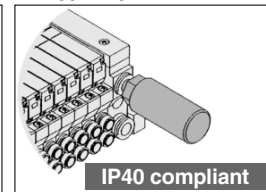

Back pressure check valve assembly [-B]
VVQ1000-18A

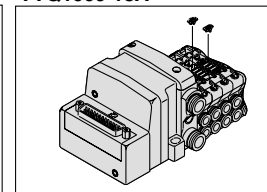

Name plate [-N]
VVQ1000-N-Stations (1 to max. no. of stations)

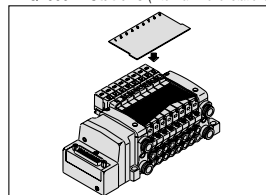

Direct EXH outlet with built-in silencer [-S]

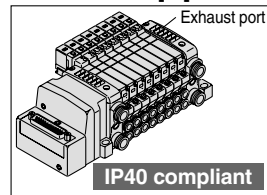

Blanking plug
KQ2P-□

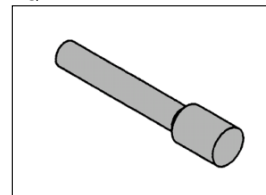

VQC

SQ

VQ0

VQ4

VQ5

VQZ

VQD

Standard Specifications

Valve Configuration		Metal seal		Rubber seal		
		Air/Inert gas				
Valve specifications	VQC1000/2000	Max. operating pressure		0.7 MPa (High pressure type: 1.0 MPa) ^{Note 4)}		
		Min. operating pressure	Single	0.1 MPa	0.15 MPa	
			Double	0.1 MPa		
			3 position	0.1 MPa	0.2 MPa	
			4 position	—	0.15 MPa	
	VQC4000	Max. operating pressure ^{Note 3)}		1.0 MPa (0.7 MPa)		
		Min. operating pressure	Single	0.15 MPa	0.2 MPa	
			Double	0.15 MPa		
	3 position	0.15 MPa	0.2 MPa			
	Proof pressure		1.5 MPa			
Ambient and fluid temperature		-10 to 50°C ^{Note 1)}				
Lubrication		Not required				
Manual override		Push type/Locking type (tool required)/Locking type (Manual override) ^{Note 5)} /Slide locking type ^{Note 5)}				
Impact resistance/Vibration resistance		150/30 m/s ² ^{Note 2)}				
Enclosure		Dust proof (IP67 compliant)				
Electrical specifications	Rated coil voltage		24 VDC			
	Allowable voltage fluctuation		±10% of rated voltage			
	Coil insulation type		Equivalent to B type			
	Power consumption (Current)	24 VDC	1 W DC (42 mA), 0.5 W DC (21 mA)			
		12 VDC	1 W DC (83 mA), 0.5 W DC (42 mA)			

- VQC
- SQ
- VQ0
- VQ4
- VQ5
- VQZ
- VQD

Note 1) Use dry air to prevent condensation at low temperatures.
 Note 2) **Impact resistance:** No malfunction resulted from the impact test using a drop impact tester. The test was performed one time each in the axial and right angle directions of the main valve and armature, for both energized and de-energized states.
Vibration resistance: No malfunction occurred in a one-sweep test between 45 and 2000Hz. Test was performed in the axial and right angle directions of the main valve and armature for both energized and de-energized states.
 Note 3) Values in () are for the low wattage (0.5 W) specification.
 Note 4) Metal seal type only.
 Note 5) Only for VQC1000/2000.



Manifold Specifications

Series	Base model	Connection type	Piping specifications		Applicable stations ^{Note 2)}	Applicable solenoid valves	5 station weight (g)
			Port direction	Port size ^{Note 1)}			
VQC1000	VV5QC11-□□□	<ul style="list-style-type: none"> ■ F Kit: D-sub connector ■ P Kit: Flat cable ■ T Kit: Terminal block box ■ S Kit: Serial transmission ■ L Kit: Lead wire ■ M Kit: Multiple connector 	Side	C8 (For ø8) Options Direct outlet with built-in silencer C3 (For ø3.2) C4 (For ø4) C6 (For ø6) M5 (M5 threads)	(F, L, M and P kits) 1 to 12 stations T kit 1 to 10 stations S kit 1 to 8 stations: EX500 1 to 12 stations: EX250 1 to 8 stations: EX126	VQC1□00-5 VQC1□01-5	628 (Single) 759 (Double, 3P)
VQC2000	VV5QC21-□□□		Side	C10 (For ø10) Options Direct outlet with built-in silencer Branch type C12 (for ø12) C4 (For ø4) C6 (For ø6) C8 (For ø8)	1 to 8 stations: EX500 1 to 12 stations: EX250 1 to 8 stations: EX126	VQC2□00-5 VQC2□01-5	1051 (Single) 1144 (Double, 3P)
VQC4000	VV5QC41-□□□		Side Bottom	C8 (For ø8) C10 (For ø10) C12 (For ø12) Rc 1/4 Rc 3/8 Rc 1/4	(F, L, M and P kits) 1 to 12 stations T kit 1 to 10 stations S kit 1 to 12 stations: EX240, EX250 1 to 8 stations: EX500 1 to 8 stations: EX126	VQC4□00-5 VQC4□01-5	4150 • S kit (without unit) • Solenoid weight is not included.

Note 1) One-touch fittings in inch sizes are also available.
 Note 2) An optional specification for special wiring is available to increase the maximum number of stations.



Series VQC

S VQC1000/2000/4000 Kit (Serial transmission kit) Decentralized Serial Wiring

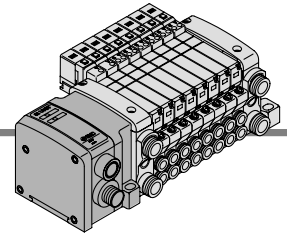

Gateway type serial transmission system

• Since wiring is "prepackaged" into one multi-connector type cable, wiring work is not only made easier, but much more accurate.

S kit can be used by connecting to gateway unit.

Gateway (GW) Unit IP65 compliant



How to Order

EX500 — G DN1

Communication protocol

DN1	DeviceNet	AB1-X1	Remote I/O (RIO)
PR1A	PROFIBUS-DP	MJ1	CC-LINK

Specifications

Model	EX500-GAB1-X1	EX500-GDN1	EX500-GPR1A	EX500-GMJ1
Applicable PLC/Communication protocol	Rockwell Automation PLC	DeviceNet Release 2.0	PROFIBUS-DP (EN50170)	CC-LINK Ver. 1.10
Communication speed	57.6/115.2/230.4 kbit/sec	125/250/500 kbit/sec	9.6/19.2/45.45/93.75/187.5/500 kbit/sec 1.5/3/6/12 Mbit/sec	156/625 kbit/sec 2.5/5/10 Mbit/sec
Rated voltage	24 VDC			
Power supply voltage range	Input and control unit power supply: 24 VDC ± 10% Solenoid valve power supply: 24 VDC + 10%/–5% (with power drop warning at approx. 20 V)			
	—	Communication power supply for DeviceNet 11 to 25 VDC	—	—
Current consumption	200 mA or less (Single GW unit)			
	—	Communication power supply for DeviceNet 50 mA or less	—	—
Number of inputs/outputs	Maximum 64 inputs/64 outputs			
Number of input/output branches	4 branches (16 inputs/16 outputs per branch)			
Branch cable	8 core heavy duty cable			
Branch cable length	5 m or less (total extension 10 m or less)			
Communication connector	M12 connector (8 pins, socket)			
Power connector	M12 connector (5 pins, plug)			
Ambient operating temperature/humidity	+5 to +45°C at 35% to 85% RH (No condensation)			
Enclosure	IP65			
Applicable standard	UL, CSA, CE			
Weight (g)	470			

Input Block IP67 compliant

How to Order Input Manifold

EEX500 — IB1 — E 8

Input unit specifications

Connector type	E	M8 connector
T	M12 connector	
M	M8 and M12 mixed	

Stations

1	1 station
...	...
8	8 stations

Applicable GW unit

Nil	DeviceNet
-X1	PROFIBUS-DP
	Remote I/O (RIO)



Note) When ordering an input block manifold, enter the [Input manifold part no.] + [Input block part no.] together. The input block, end block and DIN rail are included in the input manifold.

How to Order Input Block

EX500 — IE 1

Block type

1	M8 connector, PNP specifications
2	M8 connector, NPN specifications
3	M12 connector, PNP specifications
4	M12 connector, NPN specifications
5	8-point integrated type, M8 connector, PNP specifications
6	8-point integrated type, M8 connector, NPN specifications

Applicable GW unit

Nil	DeviceNet
-X1	PROFIBUS-DP
	Remote I/O (RIO)

* With waterproof cap

Input Unit Specifications

Connection block	Current source type input block (PNP input block) or Current sink type input block (NPN input block)
Communication connector	M12 connector (8 pins, plug)
Number of connection blocks	Maximum 8 blocks
Block supply voltage	24 VDC
Block supply current	0.65 A maximum
Current consumption	100 mA or less (at rated voltage)
Short circuit protection	Operates at 1A Typ. (power supply cut) GW unit reset by turning power OFF and back ON.
Enclosure	IP65
Weight (g) <small>Note)</small>	100 (Input unit + end block)

Note) Not including the DIN rail weight.

Input Block Specifications

Applicable sensor	Current source type (PNP output) or Current sink type (NPN output)
Sensor connector	M8 connector (3 pins) or, M12 connector (4 pins)
Number of inputs	2 inputs/8 inputs (M8 only)
Rated voltage	24 VDC
Indication	Green LED
Insulation	None
Sensor supply current	Maximum 30 mA/Sensor
Enclosure	IP65
Weight (g)	[For M8: 20] [For M12: 40] [8 point integrated type, for M8: 55]



SI Unit

How to Order

EX500 – Q001

• Applicable GW unit

Nil	DeviceNet PROFIBUS-DP
-X1	Remote I/O (RIO)

VQC

SQ

VQ0

VQ4

VQ5

VQZ

VQD

Specifications

Connection block	Solenoid valve (single, double) Relay output module (1 output, 2 outputs)
Communication connector	M12 connector (8 pins, plug, socket)
Number of connection block stations	Double solenoid valve Relay output module (2 points): Maximum 8 stations Single solenoid valve Relay output module (1 point): Maximum 16 stations
Block supply voltage	24 VDC
Block supply current	0.65 A maximum
Current consumption	100 mA or less (at rated voltage)
Weight (g)	115

Cable

How to Order Cable with M12 Connector

EX500 – AC 030 – SSPS



Cable length

003	0.3 m
005	0.5 m
010	1 m
030	3 m
050	5 m

Connector specifications

SSPS	Socket side: Straight Plug side: Straight
SAPA	Socket side: Angle Plug side: Angle

How to Order Power Cable with Connector

EX500 – AP 050 – S



Cable length

010	1 m
050	5 m

Connector specifications

S	Straight
A	Angle

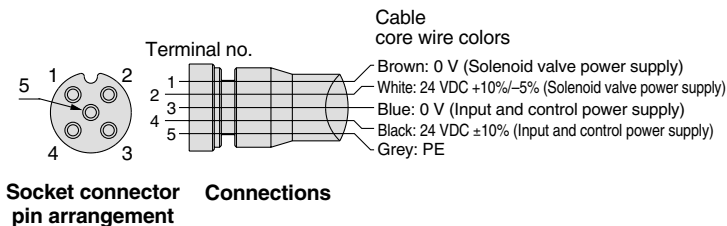
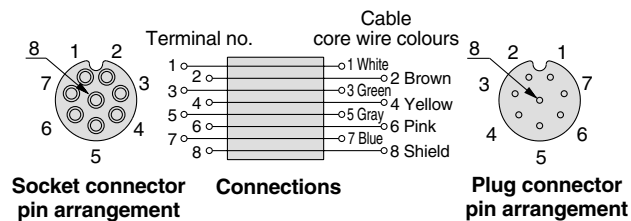



VQC1000/2000/4000

Kit (Serial transmission kit) Decentralized Serial Wiring IP67 compliant

VV5QC11

SA1 Kit (Serial transmission kit: EX500)

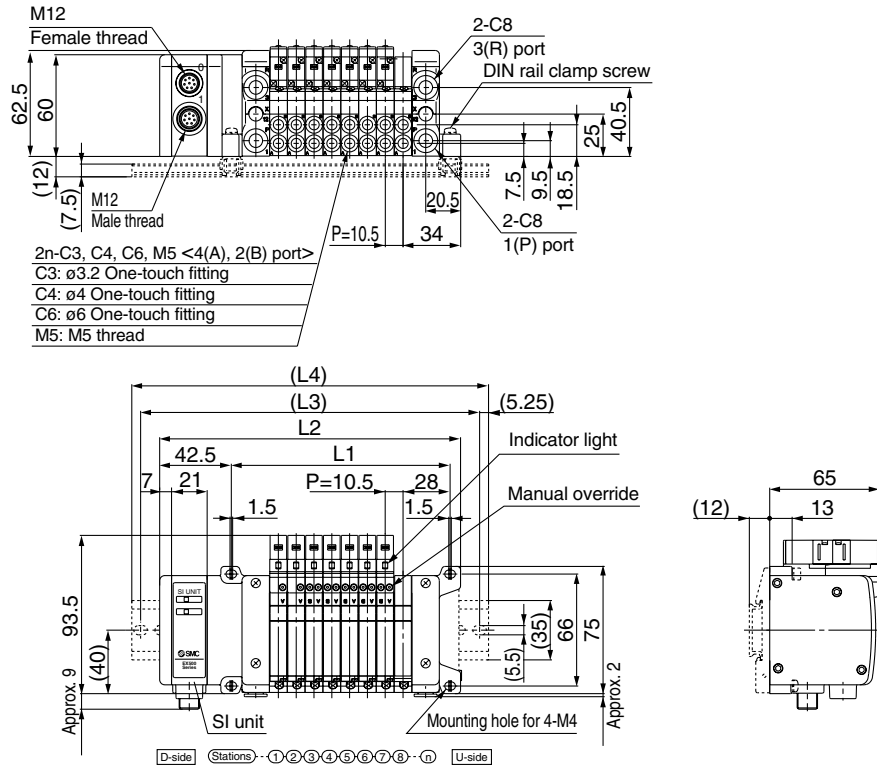

Formulas

$L1 = 10.5n + 45$ (Maximum 16 single wiring stations)

n: Stations

L \ n	1	2	3	4	5	6	7	8	9	10	11	12	13	14	15	16
L1	55.5	66	76.5	87	97.5	108	118.5	129	139.5	150	160.5	171	181.5	192	202.5	213
L2	104	114.5	125	135.5	146	156.5	167	177.5	188	198.5	209	219.5	230	240.5	251	261.5
L3	125	137.5	150	162.5	175	187.5	187.5	200	212.5	225	237.5	250	250	262.5	275	287.5
L4	135.5	148	160.5	173	185.5	198	198	210.5	223	235.5	248	260.5	260.5	273	285.5	298

* With signal cut block, L4 is obtained by adding approximately 30 mm to L2.

S VQC1000/2000/4000
Kit (Serial Transmission Kit) for I/O IP67 compliant

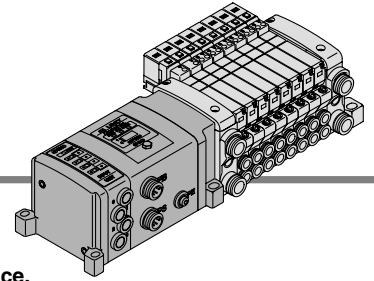

Compatible network **DeviceNet/PROFIBUS-DP/CC-Link**

• The serial transmission system greatly reduces connection work, minimizes wiring, and saves space.

SI unit for DeviceNet/PROFIBUS-DP/CC-LINK

As a DeviceNet/PROFIBUS-DP/CC-LINK slave unit, this kit is capable of up to 32 points of solenoid valve ON and OFF control. Furthermore, by connecting an input block, a maximum 32 sensor signal inputs are possible.

SI unit for AS-i

As a AS-i slave unit, this kit is capable of up to 4 or 8 points of solenoid valve ON and OFF control. Furthermore, by connecting an inpmut block, a maximun 4 or 8 sensor signal inputs are possible.

Input block

This expansion block connects to the SI unit and allows for sensor input to the auto switches. Each input block can receive input from up to two or four sensors, and the common can be matched to the sensor by an NPN/PNP selector switch. Input connectors are available in both M8 and M12 types.

Connector Details

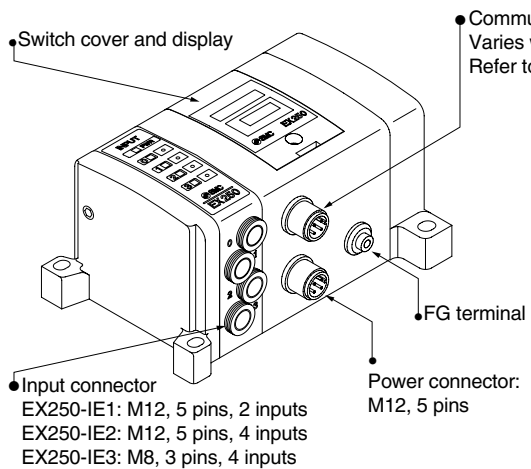

Communication connector

CANopen: Female connector cable: M12 female 5 pins cable with shield (according to ISO11898).

Pos.	Description	Function
1	CAN_SHLD	Shield
2	CAN_V+	Power supply +
3	CAN_GND	Power supply -
4	CAN_H	Bus line (dominant High)
5	CAN_L	Bus line (dominant Low)

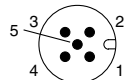

DeviceNet: M12...5 pins (Plug) Example for a cable set with plug / socket: OMRON Corporation DCA1-5CN05F1. Karl Lumberg GmbH: 0935 253 103/...M, RSC RKC 57* ... M. Accessories, bus branch Y: Karl Lumberg GmbH: 0906 UTP 101, Hans Turck GmbH: VB2-FKM-FSM57. Accessories terminating socket with resistor: Hans Turck GmbH: RSE57-TR2, Karl Lumberg GmbH: 0939 CXT 101.

Pos.	Description	Function
1	Drain	Drain / shield
2	V+	Circuit power supply +
3	V-	Circuit power supply -
4	CAN_H	Signal H
5	CAN_L	Signal L

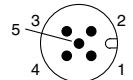

PROFIBUS-DP: M12... 5 pins reserve-keyed (Socket). Example for the corresponding cable sets with plug / socket: Hans Turck GmbH: RSSW-RKSW456-...M; Karl Lumberg GmbH: 0975 254 101/...M. Accessories Bus branch Y: Hans Turck GmbH: VB2/FSW/FKW/FSW45. Accessories terminating resistor: Hans Turck GmbH: RSS4.5-PDP-TR; Karl Lumberg GmbH: 0979PTX101

Pos.	Description	Function
1	VP	Power supply for terminating resistor
2	A-N	Negative for data transfer/reception
3	DGND	Ground for terminating resistor
4	B-P	Positive for data transfer/reception
5	SHIELD	Shield

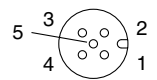

Circuit diagram Input module (EX250-IE*)

Input connection: M12 ... 5 pins (Socket)
Example for the cable side connection: OMRON Corporation XS2G;
Karl Lumberg GmbH: Series RST5; Franz Binder GmbH: Series 713,763

Pos.	Description	Function
1	SW+	Sensor power supply +
2	N.C (SIGNAL)	Open*
3	SW-	Sensor power supply -
4	SIGNAL	Sensor input signal
5	E	Sensor ground connection

* In the 4 input type unit (EX250-IE2), this is the input signal from the second sensor connected.

Power supply

DeviceNet: M12 ... 5 pins reserve-keyed (Plug)
(The configuration of the connection surface area differs from that of the transmission plug)
Example of the cable set with socket: Hans Turck GmbH: WAKW4.5T-2, Franz Binder GmbH: 79-4449-...05.

Pos.	Description	Function
1	SV24V	+24 V solenoid valve
2	SV0V	0V solenoid valve
3	SW24V	+24 V SI and input blocks
4	SW0V	0 V SI and input blocks
5	E	Ground connection

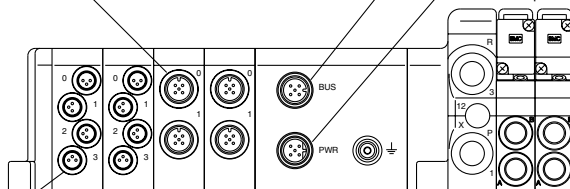
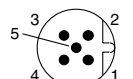

PROFIBUS-DP: M12...5 pins (Plug)
Example of the cable set with socket:
SMC: EX500-AP...S (See page 2-2-25.)

Pos.	Description	Function
1	SV24V	+24 V solenoid valve
2	SV0V	0 V solenoid valve
3	SW24V	+24 V SI and input blocks
4	SW0V	0 V SI and input blocks
5	E	Ground connection

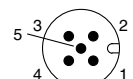

Input connection: M8 ... 3 pins (Socket)

Example for cable side connection: Franz Binder GmbH Series 718, 768
Karl Lumberg GmbH: Series RSMV3



Pos.	Description	Function
1	SW+	Sensor power supply +
3	SW-	Sensor power supply -
4	SIGNAL	Sensor input signal

AS-i EX250-SAS7 / EX250-SAS9

Communication connector: M12 male 4 pins

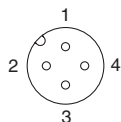

Pos.	Description	Function
1	AS-i +	Positive AS-Interface line
2	RESERVE	RESERVE
3	AS-i -	Negative AS-Interface line
4	RESERVE	RESERVE

Communication connector

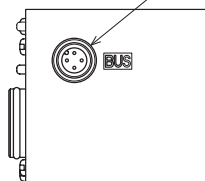

Connection example

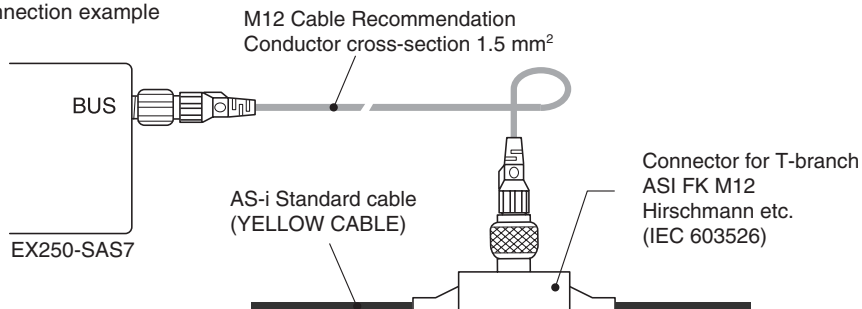

VQC

SQ

VQ0

VQ4

VQ5

VQZ

VQD

AS-i EX250-SAS3 / EX250-SAS5

Communication connector: M12 male 4 pins

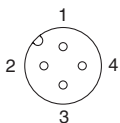

Pos.	Description	Function
1	AS-i +	Positive AS-Interface line
2	0V	Negative output equipment power line
3	AS-i -	Negative AS-Interface line
4	24V	Positive output equipment power line

Output equipment power connector: M12 male 4 pins

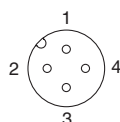

Pos.	Description	Function
1	24V	Positive output equipment power line
2	NC	Not connected
3	0V	Negative output equipment power line
4	NC	Not connected

* Connected inside the SI unit.

Communication connector

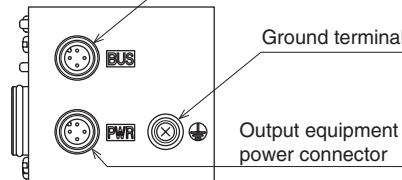

Connection example

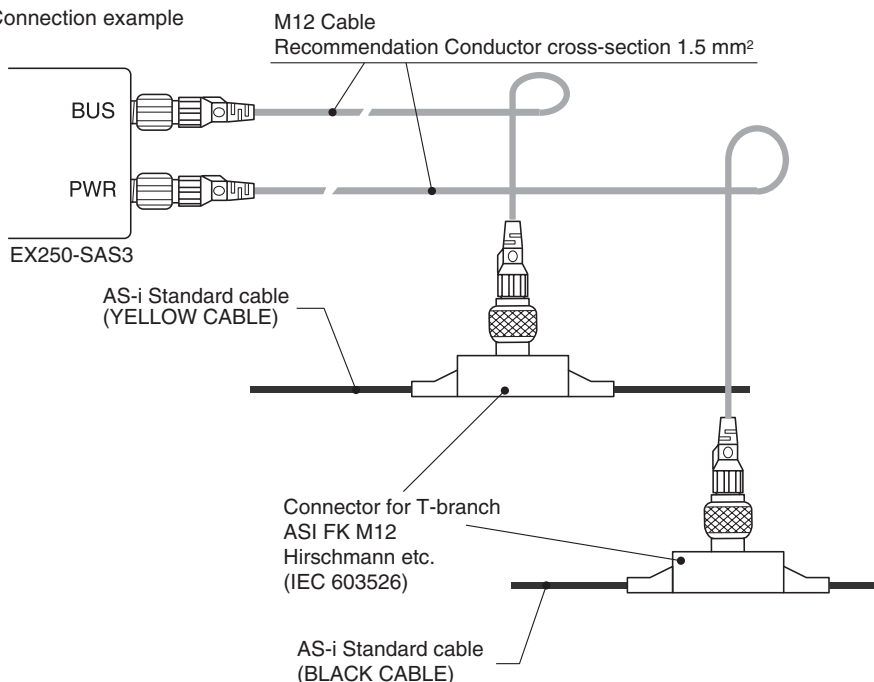

S VQC1000/2000/4000 Kit (Serial transmission kit) for I/O IP67 compliant

Indicator Unit (LED) Description and Its Function

SI unit

DeviceNet (EX250-SDN1)

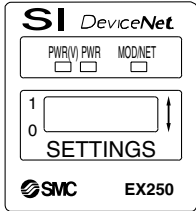

Name	Function
PWR(V)	ON when solenoid valve power supply is turned ON.
PWR	ON when DeviceNet circuit power supply input is turned ON.
MOD/NET	OFF: Power supply off, off line, or when checking duplication of MAC_ID.
	GREEN BLINKING: Waiting for connection (on line).
	GREEN ON: Connection established (on line).
	RED BLINKING: Connection time out (minor communication abnormality).
	RED ON: MAC_ID duplication error, or BUSOFF error (major communication abnormality).

Input block (EX250-IE1/2/3)

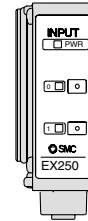

2-input type (EX250-IE1)

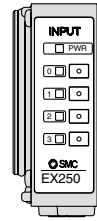

4-input type (EX250-IE2/3)

Description	Function
PWR	ON when sensor power is turned ON.
0 to 1(3)	ON when each sensor input goes ON.



* Please contact your SMC representative for specifications and handling precautions.

PROFIBUS-DP (EX250-SPR1)

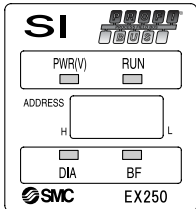

Name	Function
PWR(V)	GREEN ON when solenoid valve power supply is turned ON. GREEN OFF when the power supply voltage is less than 19 V.
RUN	GREEN ON when operating (SI unit power supply is ON).
DIA	RED ON when self diagnosis device detects abnormality.
BF	RED ON for BUS abnormality.

CC-Link (EX250-SMJ2)

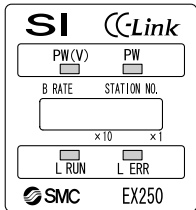

Name	Function
PW	ON: Input and control unit power supply ON. OFF: Input and control unit power supply OFF.
PW(V)	ON: Solenoid valve power supply ON. OFF: Solenoid valve power supply voltage is less than 19 V.
L RUN	ON: Normal traffic OFF: Traffic disconnected (Timeover error)
L ERR	ON: Traffic error BLINKING: Station or baud rate switch is set while the power supply is ON. OFF: Normal traffic

When the data link is normal, PW, PW (V) and L RUN are ON.

AS-i (EX250-SAS□)

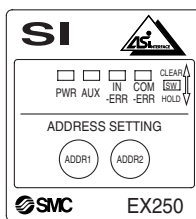

Name	LED Condition	Contents
PWR	Green Light	In time of power supply for AS-Interface line is turned on.
AUX	Green Light	In time of auxiliary power supply for output equipment is turned on.
IN-ERR	Red Light	In time of input power is detected over current. (Lights off at normal condition)
COM-ERR	Red Light	In time of communication error. (Lights off at normal condition)
	Red Blink	In time of peripheral equipment error. (Over current of input power, blowing the fuse etc.)

SI unit

CANopen (EX250-SCA1)

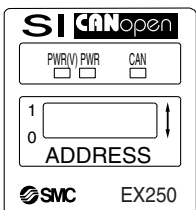

Name	LED Condition	Contents
PWR(V)	Green Light	Illuminates when power for solenoid valves is supplied
	Green Light	Illuminates when power for CANopen line is supplied
PWR	Green Light	Illuminates when SI unit is in the Operational state
	Green Light (Blinking)	SI unit is in the Pre-operational state
	Green Light (Single flash)	Single flash when SI unit is in Stopped state
	Red Light (Single flash)	Single flash when CAN controller error occurs
	Red Light (Double flash)	Double flash when Error Control Event occurs
	Green/Red Light (flickering)	Flickering when SI unit is in Configuration mode (LSS services)
	Red Light	Red Light SI unit is in "Bus OFF" state

VV5QC11
S Kit
 (Serial transmission
 kit: EX250)

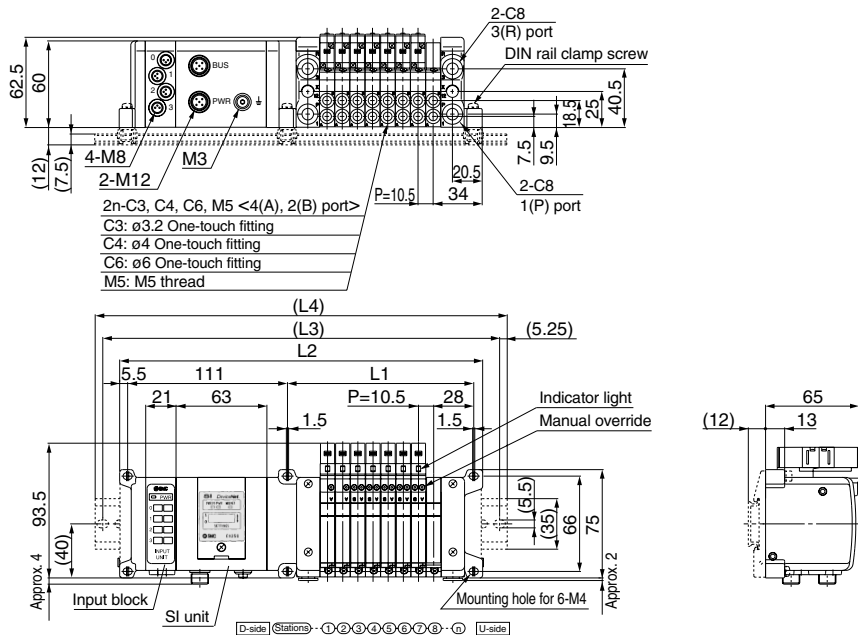

Formulas
 $L1 = 10.5n + 45$ (Maximum 24 single wiring stations)
 * $L2$: For one input block. Add 21 mm for each additional input block.

L \ n	1	2	3	4	5	6	7	8	9	10	11	12	13	14	15	16	17	18	19	20	21	22	23	24
L1	55.5	66	76.5	87	97.5	108	118.5	129	139.5	150	160.5	171	181.5	192	202.5	213	223.5	234	244.5	255	265.5	276	286.5	297
L2	178	188.5	199	209.5	220	230.5	241	251.5	262	272.5	283	293.5	304	314.5	325	335.5	346	356.5	367	377.5	388	398.5	409	419.5
L3	200	212.5	225	237.5	250	250	262.5	275	287.5	300	312.5	325	325	337.5	350	362.5	375	387.5	387.5	400	412.5	425	437.5	450
L4	210.5	223	235.5	248	260.5	260.5	273	285.5	298	310.2	323	335.5	335.5	348	360.5	373	385.5	398	398	410.5	423	435.5	448	448

* With signal cut block, L4 is obtained by adding approximately 30 mm to L2.

VV5QC21
S Kit
 (Serial transmission
 kit: EX250)

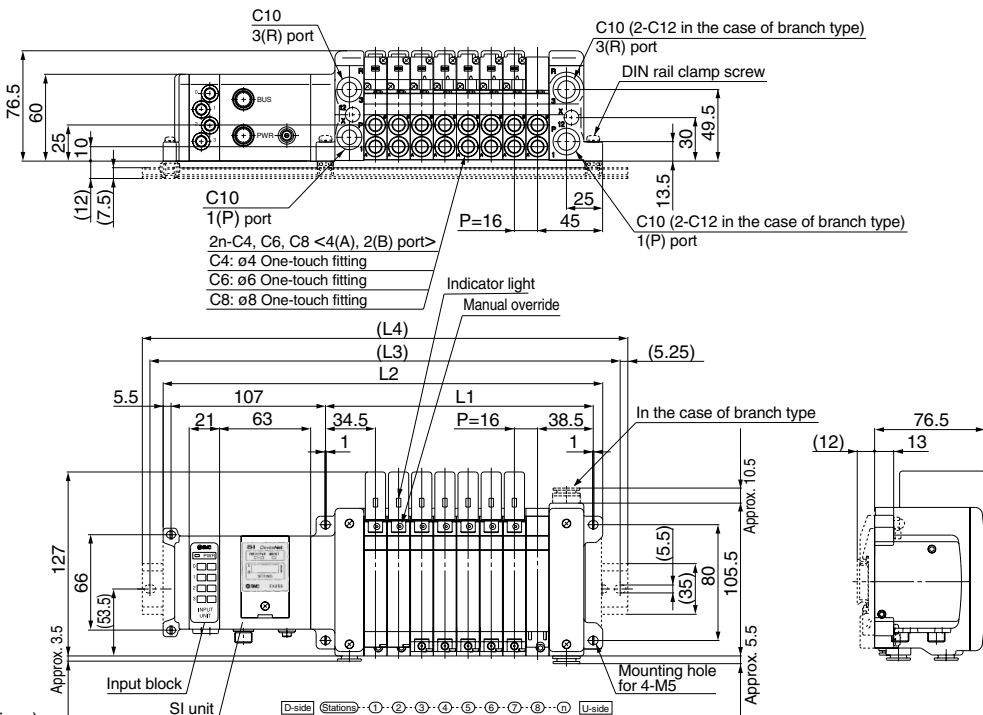

Formulas
 $L1 = 16n + 57$ (Maximum 24 single wiring stations)
 * $L2$: For one input block. Add 21 mm for each additional input block.

L \ n	1	2	3	4	5	6	7	8	9	10	11	12	13	14	15	16	17	18	19	20	21	22	23	24
L1	73	89	105	121	137	153	169	185	201	217	233	249	265	281	297	313	329	345	361	377	393	409	425	441
L2	192	208	224	240	256	272	288	304	320	336	352	368	384	400	416	432	448	464	480	496	512	528	544	560
L3	212.5	237.5	250	262.5	275	287.5	312.5	325	337.5	362.5	375	387.5	400	425	437.5	450	462.5	487.5	500	512.5	537.5	550	562.5	587.5
L4	223	248	260.5	273	285.5	298	323	335.5	348	373	385.5	398	410.5	435.5	448	460.5	473	498	510.5	523	548	560.5	573	598

* With signal cut block, L4 is obtained by adding approximately 30 mm to L2.

- VQC
- SQ
- VQ0
- VQ4
- VQ5
- VQZ
- VQD

S VQC1000/2000/4000
Kit (Serial transmission kit) for I/O IP67 compliant

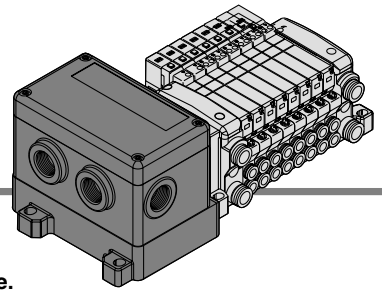

Compatible network **CC-Link**

- The serial transmission system greatly reduces connection work, minimizes wiring, and saves space.

Terminal Block Connection

Step 1. How to remove terminal block cover

Loosen the 4 mounting screws (M4) and remove the terminal block cover.

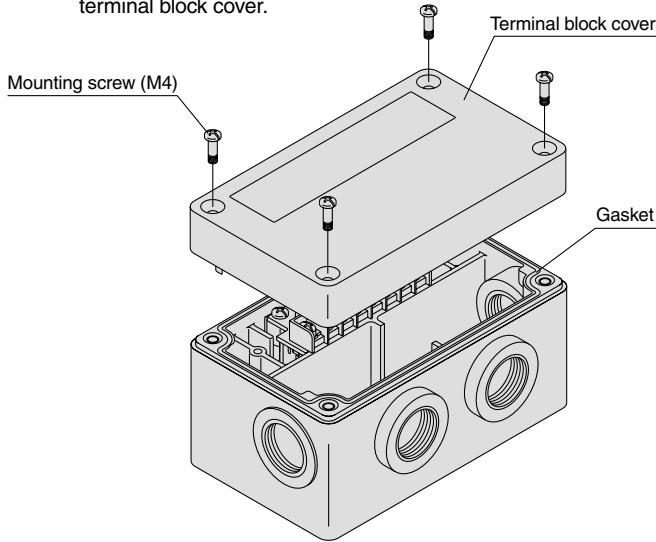

Step 2. Wire the cables according to the terminal block specifications below. Pay attention to the wire bound positions.

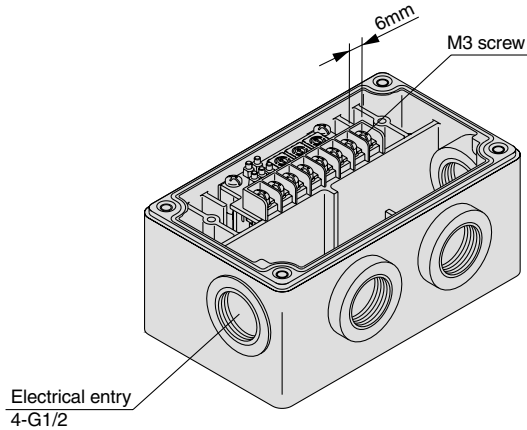

Step 3. How to replace the terminal block cover

Securely tighten the screws to the torque shown in the table below, after confirming that the gasket is installed correctly.

Proper tightening torque (N·m)
0.7 to 1.2

- Applicable crimp terminal (fork tongue type): 1.25-3S, 1.25Y-3, 1.25Y-3N, 1.25Y-3.5

* For detailed specifications and handling, refer to the operation manual provided by SMC.

Terminal Block Details

• Terminal block LED descriptions

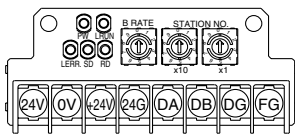

Description	Function
PW	ON when transmission power supply is ON. OFF when transmission power supply is OFF.
L RUN	ON when normal data is received.
SD	ON when data is sent.
RD	ON when data is received.
L ERR.	ON for transmission error and incorrect settings. BLINKING for change in station or transmission speed settings.

• Cable wiring

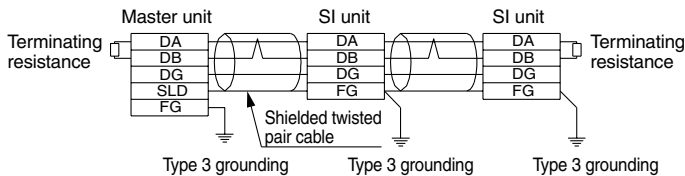

• Note

- CC-LINK System
 - Master unit: AJ61BT11
 - Master unit: A1SJ61BT11
 - Master unit: AJ61QBT11
 - Master unit: A1SJ61QBT11

- 16 outputs

VV5QC11
S Kit (Serial transmission kit: EX126)

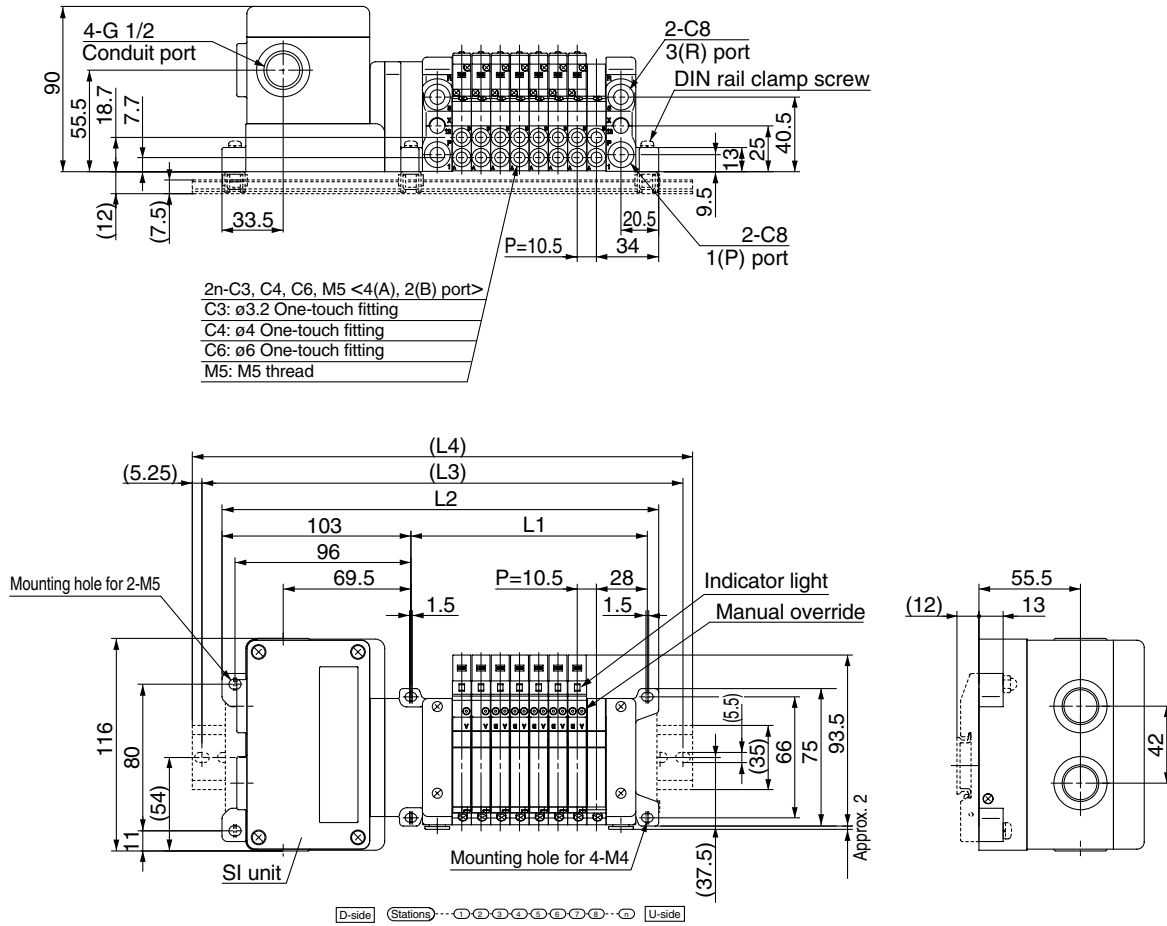

- VQC
- SQ
- VQ0
- VQ4
- VQ5
- VQZ
- VQD

Formulas
 $L1 = 10.5n + 45$ (Maximum 16 single wiring stations)
 $L2 = 10.5n + 154.5$

n: Stations

L \ n	1	2	3	4	5	6	7	8	9	10	11	12	13	14	15	16
L1	55.5	66	76.5	87	97.5	108	118.5	129	139.5	150	160.5	171	181.5	192	202.5	213
L2	165	175.5	186	196.5	207	217.5	228	238.5	249	259.5	270	280.5	291	301.5	312	322.5
L3	187.5	200	212.5	212.5	225	237.5	250	262.5	275	275	287.5	300	312.5	325	337.5	337.5
L4	198	210.5	223	223	235.5	248	260.5	273	285.5	285.5	298	310.5	323	335.5	348	348

* With signal cut block, L4 is obtained by adding approximately 30 mm to L2.

Series VQC

Manifold Option

■ Circular connector/Cable assembly (26 pins)

AXT100 – MC26 – □

Lead Wire Length

Part no.	L dimension
AXT100-MC26-015	1.5 m
AXT100-MC26-030	3 m
AXT100-MC26-050	5 m

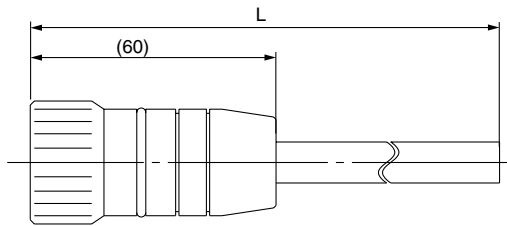

Plug terminal no.
(arrangement as seen from lead wire side)

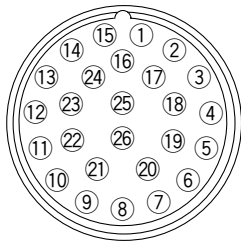

Circular Connector Cable Assembly Terminal No.

Terminal no.	Lead wire color	Dot marking
①	Black	None
②	Brown	None
③	Red	None
④	Orange	None
⑤	Yellow	None
⑥	Pink	None
⑦	Blue	None
⑧	Purple	White
⑨	Gray	Black
⑩	White	Black
⑪	White	Red
⑫	Yellow	Red
⑬	Orange	Red
⑭	Yellow	Black
⑮	Pink	Black
⑯	Blue	White
⑰	Purple	None
⑱	Gray	None
⑲	Orange	Black
⑳	Red	White
㉑	Brown	White
㉒	Pink	Red
㉓	Gray	Red
㉔	Black	White
㉕	White	None

Note) Terminal no. ㉖ is connected to ㉕ inside the connector.

■ D-sub connector/Cable assembly (25 pins)

AXT100 – DS25 – □

Lead Wire Length

Part no.	L dimension
AXT100-DS25-015	1.5 m
AXT100-DS25-030	3 m
AXT100-DS25-050	5 m

When a commercially available connector is required, use a 25 pin female connector conforming to MIL-C24308.

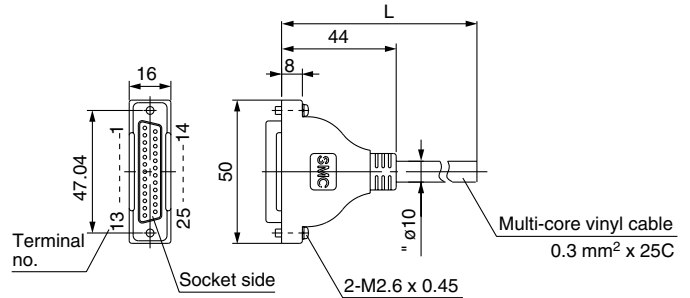

D-sub Connector Cable Assembly Terminal No.

Terminal no.	Lead wire color	Dot marking
①	Black	None
②	Brown	None
③	Red	None
④	Orange	None
⑤	Yellow	None
⑥	Pink	None
⑦	Blue	None
⑧	Purple	White
⑨	Gray	Black
⑩	White	Black
⑪	White	Red
⑫	Yellow	Red
⑬	Orange	Red
⑭	Yellow	Black
⑮	Pink	Black
⑯	Blue	White
⑰	Purple	None
⑱	Gray	None
⑲	Orange	Black
⑳	Red	White
㉑	Brown	White
㉒	Pink	Red
㉓	Gray	Red
㉔	Black	White
㉕	White	None

Circular Connector, D-sub Connector Cable Assembly Electric Characteristics

Item	Characteristics
Conductor resistance W/km, 20°C	65 or less
Withstand voltage VAC, 1 min.	1000
Insulation resistance, M/km, 20°C	5 or less

Note) The minimum inside bending radius for each cable is 20 mm.

VV5QC11

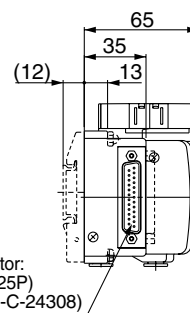
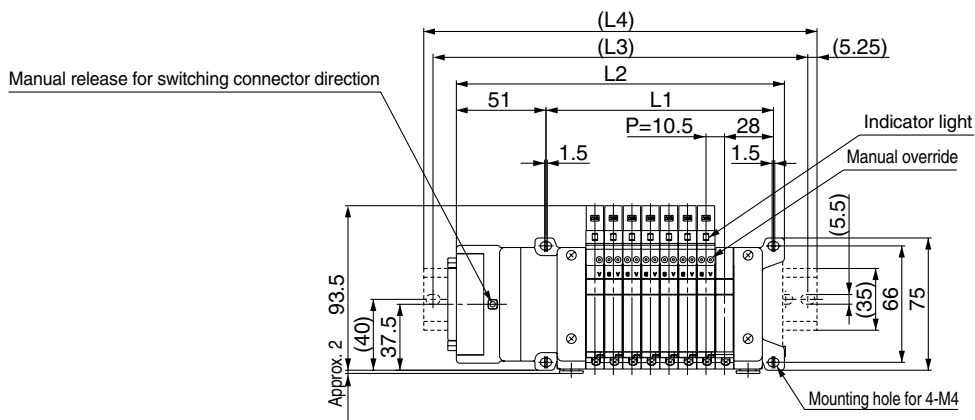
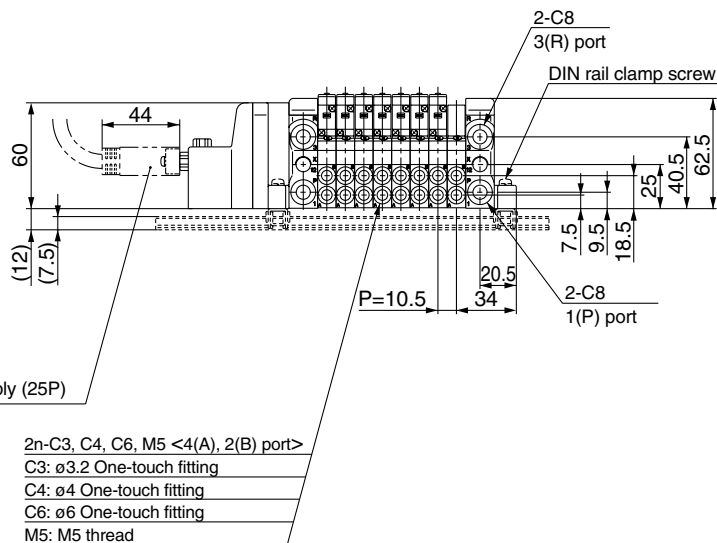

D-side Stations ① ② ③ ④ ⑤ ⑥ ⑦ ⑧ ⑨ U-side

Formulas

$L1 = 10.5n + 45$ (Maximum 24 single wiring stations)

$L2 = 10.5n + 102$

n: Stations

L \ n	1	2	3	4	5	6	7	8	9	10	11	12	13	14	15	16	17	18	19	20	21	22	23	24
L1	55.5	66	76.5	87	97.5	108	118.5	129	139.5	150	160.5	171	181.5	192	202.5	213	223.5	234	244.5	255	265.5	276	286.5	297
L2	112.5	123	133.5	144	154.5	165	175.5	186	196.5	207	217.5	228	238.5	249	259.5	270	280.5	291	301.5	312	322.5	333	343.5	354
L3	137.5	150	162.5	175	187.5	200	212.5	225	237.5	250	262.5	275	287.5	300	300	312.5	325	337.5	350	362.5	375	375	375	375
L4	148	160.5	173	185.5	198	210.5	223	235.5	248	260.5	273	285.5	298	310.5	310.5	323	335.5	348	360.5	373	385.5	385.5	385.5	385.5

* With signal cut block, L4 is obtained by adding approximately 30 mm to L2.

- VQC
- SQ
- VQ0
- VQ4
- VQ5
- VQZ
- VQD

Series VQC

P VQC1000/2000/4000
Kit (Flat ribbon cable kit) IP40 compliant

- Using our flat ribbon cable for electrical connections greatly reduces labour, while it also minimizes wiring and saves space.
- We use flat ribbon cables whose connectors (26P and 20P) conform to MIL standards, and are therefore widely compatible with many standard commercial models.
- Top or side entry for the connector can be changed freely, allowing for changes even after mounting, to meet any changing needs for space.

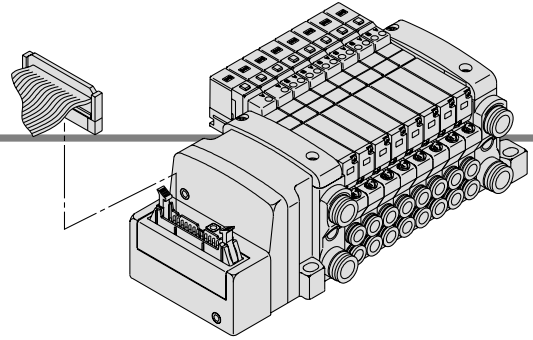

Electrical Wiring Specifications

Flat ribbon cable connector

Double wiring (connected to SOL. A and SOL. B) is used for the internal wiring of each station regardless of valve and option types. Mixed single and double wiring are available as options. Refer to special wiring specifications (options) below.

Connector terminal number

Triangle mark indicator position

<26P>			<20P>		
Station	Terminal no.	Polarity	Station	Terminal no.	Polarity
Station 1	SOL. A 1	(-) (+)	Station 1	SOL. A 1	(-) (+)
	SOL. B 2	(-) (+)		SOL. B 2	(-) (+)
Station 2	SOL. A 3	(-) (+)	Station 2	SOL. A 3	(-) (+)
	SOL. B 4	(-) (+)		SOL. B 4	(-) (+)
Station 3	SOL. A 5	(-) (+)	Station 3	SOL. A 5	(-) (+)
	SOL. B 6	(-) (+)		SOL. B 6	(-) (+)
Station 4	SOL. A 7	(-) (+)	Station 4	SOL. A 7	(-) (+)
	SOL. B 8	(-) (+)		SOL. B 8	(-) (+)
Station 5	SOL. A 9	(-) (+)	Station 5	SOL. A 9	(-) (+)
	SOL. B 10	(-) (+)		SOL. B 10	(-) (+)
Station 6	SOL. A 11	(-) (+)	Station 6	SOL. A 11	(-) (+)
	SOL. B 12	(-) (+)		SOL. B 12	(-) (+)
Station 7	SOL. A 13	(-) (+)	Station 7	SOL. A 13	(-) (+)
	SOL. B 14	(-) (+)		SOL. B 14	(-) (+)
Station 8	SOL. A 15	(-) (+)	Station 8	SOL. A 15	(-) (+)
	SOL. B 16	(-) (+)		SOL. B 16	(-) (+)
Station 9	SOL. A 17	(-) (+)	Station 9	SOL. A 17	(-) (+)
	SOL. B 18	(-) (+)		SOL. B 18	(-) (+)
Station 10	SOL. A 19	(-) (+)	Station 10	COM 19	(+) (-)
	SOL. B 20	(-) (+)		COM 20	(+) (-)
Station 11	SOL. A 21	(-) (+)			
	SOL. B 22	(-) (+)			
Station 12	SOL. A 23	(-) (+)			
	SOL. B 24	(-) (+)			
	COM 25	(+) (-)			
	COM 26	(+) (-)			

Positive COM. spec. Negative COM. spec.

Note) When using the negative COM. specification for VQC1000/2000, use valves for negative COM.

Cable Assembly

AXT100-FC¹₂₆₋₂³

(Type 26P flat ribbon cable connector assemblies can be ordered with manifolds. Refer to manifold ordering.)

Terminal no. Red 28AWG

30 (20P) 37.5 (26P)

6 (15.6) L

Flat ribbon cable connector assemblies (Option)

Cable length (L)	Part no.	
	26P	20P
1.5 m	AXT100-FC26-1	AXT100-FC20-1
3 m	AXT100-FC26-2	AXT100-FC20-2
5 m	AXT100-FC26-3	AXT100-FC20-3

* When using a standard commercial connector, use a type 26P connector conforming to MIL-C-83503 or a type 20P with strain relief.
* Cannot be used for transfer wiring.

Connector Manufacturers Example:

- Hirose Electric CO., Ltd.
- Sumitomo/3-M Limited
- Fujitsu, Ltd.
- Japan Aviation Electronics Industry, Ltd.
- J.S.T. Mfg. Co., Ltd.
- Oki Electric Cable Co., Ltd.

Special Wiring Specifications (Option)

COM. COM. COM. COM.

(For 26P) (For 20P)

Mixed single and double wiring are available as options. The maximum number of manifold stations is determined by the number of solenoids. Count one point for a single solenoid type and two points for a double solenoid type. The total number of solenoids (points) must not exceed 24.

VV5QC11

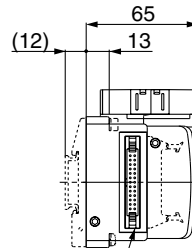
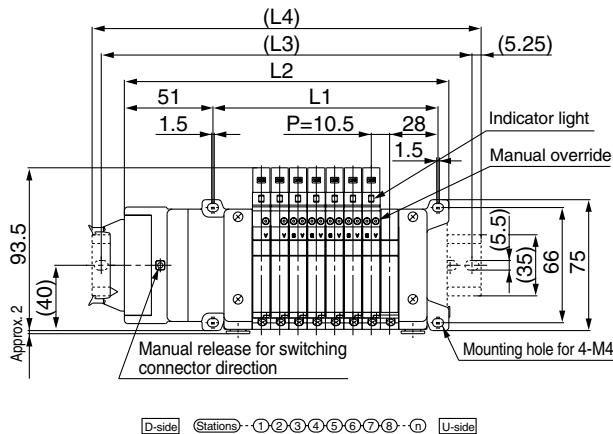
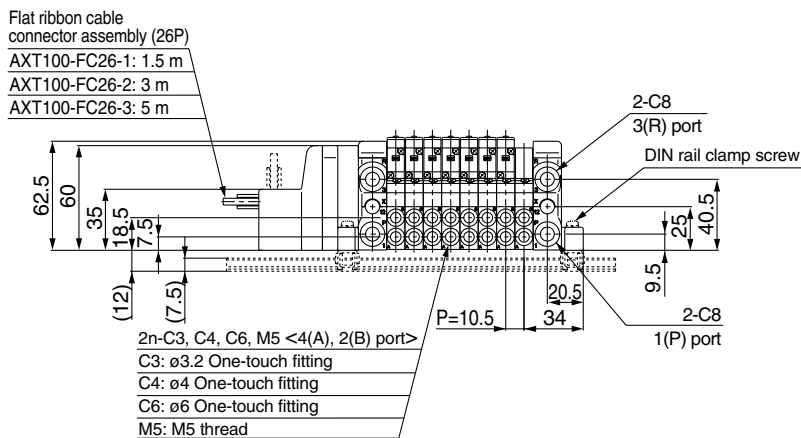

Applicable connector:
Flat ribbon cable connector (26P)
(Conforms to MIL-C-83503)

Formulas
L1 = 10.5n + 45 (Maximum 24 single wiring stations)
L2 = 10.5n + 102

n: Stations

L \ n	1	2	3	4	5	6	7	8	9	10	11	12	13	14	15	16	17	18	19	20	21	22	23	24
L1	55.5	66	76.5	87	97.5	108	118.5	129	139.5	150	160.5	171	181.5	192	202.5	213	223.5	234	244.5	255	265.5	276	286.5	297
L2	112.5	123	133.5	144	154.5	165	175.5	186	196.5	207	217.5	228	238.5	249	259.5	270	280.5	291	301.5	312	322.5	333	343.5	354
L3	137.5	150	162.5	175	187.5	200	212.5	225	237.5	250	262.5	275	287.5	300	300	312.5	325	337.5	350	362.5	375	375	375	375
L4	148	160.5	173	185.5	198	210.5	223	235.5	248	260.5	273	285.5	298	310.5	310.5	323	335.5	348	360.5	373	385.5	385.5	385.5	385.5

* With signal cut block, L4 is obtained by adding approximately 30 mm to L2.

VQC

SQ

VQ0

VQ4

VQ5

VQZ

VQD

T VQC1000/2000/4000
Kit (Terminal block box kit) IP67 compliant

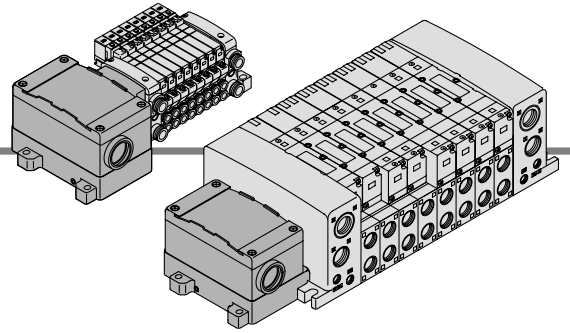

• This kit has a small terminal block inside a junction box. The provision of a G 3/4 electrical entry allows connection of conduit fittings.

Terminal Block Connection

Step 1. How to remove terminal block cover

Loosen the 4 mounting screws (M4) and remove the terminal block cover.

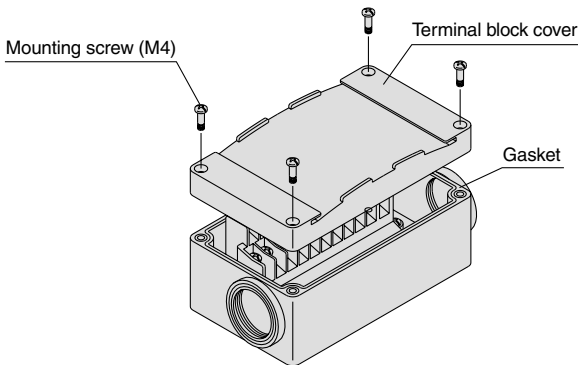

Step 2. The diagram below shows the terminal block wiring.

All stations are provided with double wiring regardless of the valves which are mounted.

Connect each wire to the power supply side, according to the markings provided inside the terminal block.

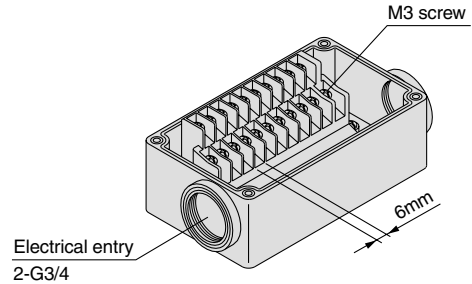

Step 3. How to replace the terminal block cover

Securely tighten the screws to the torque shown in the table below, after confirming that the gasket is installed correctly.

Proper tightening torque (N·m)
0.7 to 1.2

• Applicable crimp terminal (fork tongue type): 1.25-3S, 1.25Y-3, 1.25Y-3N, 1.25Y-3.5

Electrical Wiring Specifications (Conforms to IP67)

The internal wiring is double (connected to SOL. A and SOL. B) for all stations regardless of the type of valve or options. Mixed single and double wiring are available as options.

Note) When using the negative COM. specification for VQC1000/2000, use valves for negative COM.

	Terminal no.	Polarity
Station 1	SOL. A 1A	(-) (+)
	SOL. B 1B	(-) (+)
Station 2	SOL. A 2A	(-) (+)
	SOL. B 2B	(-) (+)
Station 3	SOL. A 3A	(-) (+)
	SOL. B 3B	(-) (+)
Station 4	SOL. A 4A	(-) (+)
	SOL. B 4B	(-) (+)
Station 5	SOL. A 5A	(-) (+)
	SOL. B 5B	(-) (+)
Station 6	SOL. A 6A	(-) (+)
	SOL. B 6B	(-) (+)
Station 7	SOL. A 7A	(-) (+)
	SOL. B 7B	(-) (+)
Station 8	SOL. A 8A	(-) (+)
	SOL. B 8B	(-) (+)
Station 9	SOL. A 9A	(-) (+)
	SOL. B 9B	(-) (+)
Station 10	SOL. A 10A	(-) (+)
	SOL. B 10B	(-) (+)
	COM.	(+) (-)

Positive COM. Negative COM.

Special Wiring Specifications (Option)

Mixed single and double wiring are available as options. The maximum number of manifold stations is determined by the number of solenoids. Count one point for a single solenoid type and two points for a double solenoid type. The total number of solenoids (points) must not exceed 20.

1. How to order

Indicate option symbol "-K" in the manifold part number and be sure to specify station positions for single or double wiring on the manifold specification sheet.

2. Wiring specifications

Connector terminal numbers are connected from solenoid station 1 on the A side in the order indicated by the arrows without skipping any terminal numbers.

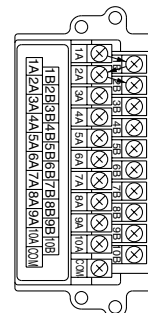

VV5QC11

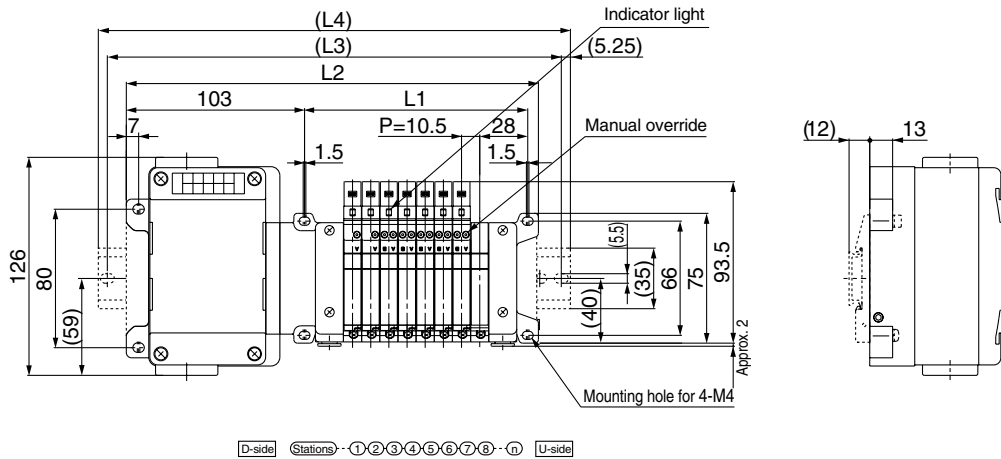
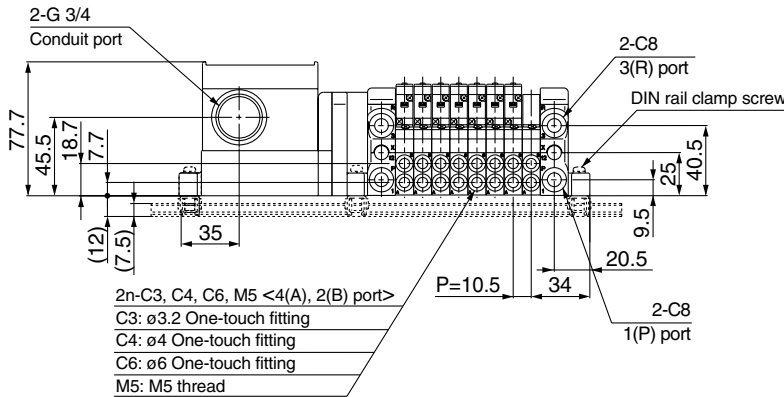

- VQC
- SQ
- VQ0
- VQ4
- VQ5
- VQZ
- VQD

Formulas

$L1 = 10.5n + 45$ (Maximum 20 single wiring stations)

$L2 = 10.5n + 154.5$

n: Stations

L \ n	1	2	3	4	5	6	7	8	9	10	11	12	13	14	15	16	17	18	19	20
L1	55.5	66	76.5	87	97.5	108	118.5	129	139.5	150	160.5	171	181.5	192	202.5	213	223.5	234	244.5	255
L2	165	175.5	186	196.5	207	217.5	228	238.5	249	259.5	270	280.5	291	301.5	312	322.5	333	343.5	354	364.5
L3	187.5	200	212.5	212.5	225	237.5	250	262.5	275	275	287.5	300	312.5	325	337.5	337.5	350	362.5	375	387.5
L4	198	210.5	223	223	235.5	248	260.5	273	285.5	285.5	298	310.5	323	335.5	348	348	360.5	373	385.5	398

* With signal cut block, L4 is obtained by adding approximately 30 mm to L2.

Series VQC

L VQC1000/2000/4000
Kit (Lead wire kit) IP67 compliant

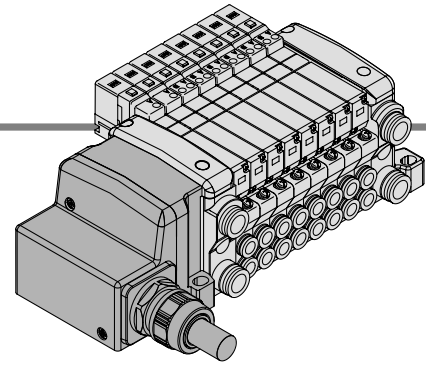

- Direct electrical entry type.
- IP67 enclosure is available with use of cables with sheath and waterproof connectors.

Electrical Wiring Specifications

Lead wire specifications

Lead wire
0.3 mm² × 25 core

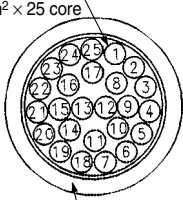

As the standard electrical wiring specification used is for 12 stations or less, double wiring (connected to SOL. A and SOL. B) is used for the internal wiring of each station regardless of valve and option types. Mixed single and double wiring are available as options. Refer to special wiring specifications (options) below.

Lead wire length

VV5QC11-08 C6 LD 0

Lead wire length

0	0.6 m
1	1.5 m
2	3.0 m

Electrical characteristics

Item	Characteristic
Conductor resistance Ω/km, 20°C	65 or less
Withstand pressure V, 1 minute, AC	1000
Insulation resistance MΩ/km, 20°C	5 or more

Note) Cannot be used for transfer wiring. The minimum bending radius for cables is 20 mm.

	Terminal no.	Polarity		Lead wire colour	Dot marking
Station 1	SOL. A 1	(-)	(+)	Black	None
	SOL. B 14	(-)	(+)	Yellow	Black
Station 2	SOL. A 2	(-)	(+)	Brown	None
	SOL. B 15	(-)	(+)	Pink	Black
Station 3	SOL. A 3	(-)	(+)	Red	None
	SOL. B 16	(-)	(+)	Blue	White
Station 4	SOL. A 4	(-)	(+)	Orange	None
	SOL. B 17	(-)	(+)	Purple	None
Station 5	SOL. A 5	(-)	(+)	Yellow	None
	SOL. B 18	(-)	(+)	Grey	None
Station 6	SOL. A 6	(-)	(+)	Pink	None
	SOL. B 19	(-)	(+)	Orange	Black
Station 7	SOL. A 7	(-)	(+)	Blue	None
	SOL. B 20	(-)	(+)	Red	White
Station 8	SOL. A 8	(-)	(+)	Purple	White
	SOL. B 21	(-)	(+)	Brown	White
Station 9	SOL. A 9	(-)	(+)	Grey	Black
	SOL. B 22	(-)	(+)	Pink	Red
Station 10	SOL. A 10	(-)	(+)	White	Black
	SOL. B 23	(-)	(+)	Grey	Red
Station 11	SOL. A 11	(-)	(+)	White	Red
	SOL. B 24	(-)	(+)	Black	White
Station 12	SOL. A 12	(-)	(+)	Yellow	Red
	SOL. B 25	(-)	(+)	White	None
	COM. 13	(+)	(-)	Orange	Red

Positive COM. spec. Negative COM. spec. Note)

Note) When using the negative COM. specification for VQC1000/2000, use valves for negative COM.

Special Wiring Specifications (Option)

Mixed single and double wiring are available as options. The maximum number of manifold stations is determined by the number of solenoids. Count one point for a single solenoid type and two points for a double solenoid type. The total number of solenoids (points) must not exceed 24.

VV5QC11

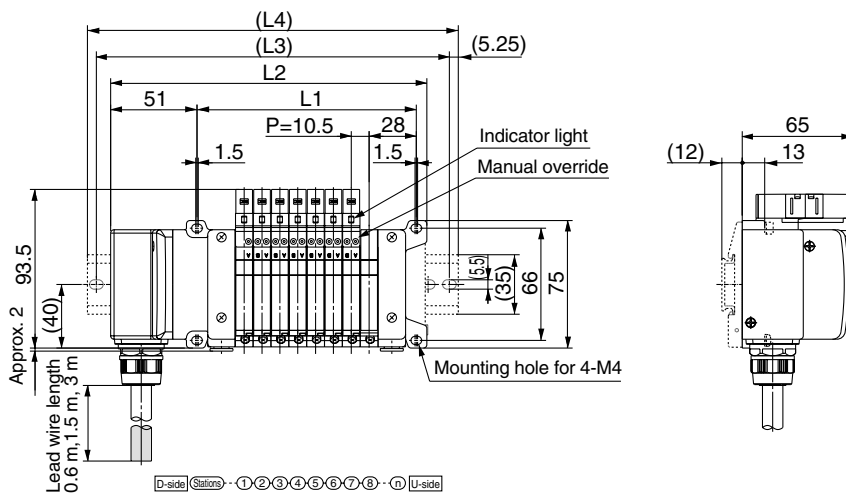
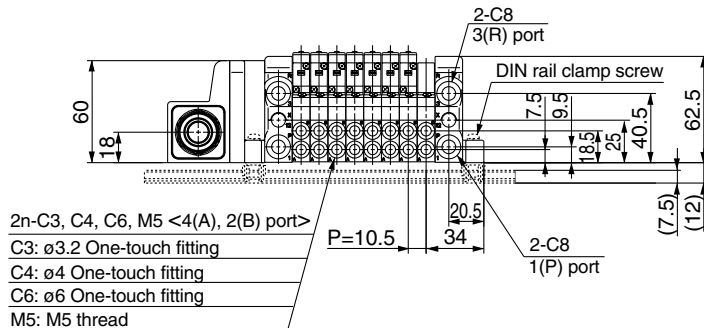

- VQC
- SQ
- VQ0
- VQ4
- VQ5
- VQZ
- VQD

Formulas

$L1 = 10.5n + 45$ (Maximum 24 single wiring stations)

$L2 = 10.5n + 102$

n: Stations

L \ n	1	2	3	4	5	6	7	8	9	10	11	12	13	14	15	16	17	18	19	20	21	22	23	24
L1	55.5	66	76.5	87	97.5	108	118.5	129	139.5	150	160.5	171	181.5	192	202.5	213	223.5	234	244.5	255	265.5	276	286.5	297
L2	112.5	123	133.5	144	154.5	165	175.5	186	196.5	207	217.5	228	238.5	249	259.5	270	280.5	291	301.5	312	322.5	333	343.5	354
L3	137.5	150	162.5	175	187.5	200	212.5	225	237.5	250	262.5	275	287.5	300	300	312.5	325	337.5	350	362.5	375	385.5	375	375
L4	148	160.5	173	185.5	198	210.5	223	235.5	248	248	260.5	273	285.5	298	310.5	310.5	323	335.5	348	360.5	373	385.5	385.5	385.5

* With signal cut block, L4 is obtained by adding approximately 30 mm to L2.

Series VQC

Manifold Option

■ Circular connector/Cable assembly (26 pins)

AXT100 – MC26 – □

Lead Wire Length

Part no.	L dimension
AXT100-MC26-015	1.5 m
AXT100-MC26-030	3 m
AXT100-MC26-050	5 m

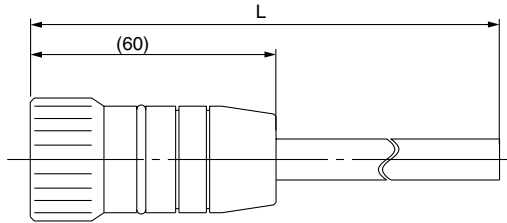

Plug terminal no.
(arrangement as seen from lead wire side)

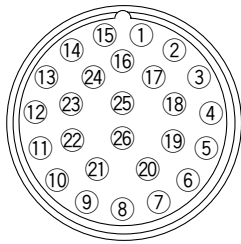

Circular Connector Cable Assembly Terminal No.

Terminal no.	Lead wire color	Dot marking
①	Black	None
②	Brown	None
③	Red	None
④	Orange	None
⑤	Yellow	None
⑥	Pink	None
⑦	Blue	None
⑧	Purple	White
⑨	Gray	Black
⑩	White	Black
⑪	White	Red
⑫	Yellow	Red
⑬	Orange	Red
⑭	Yellow	Black
⑮	Pink	Black
⑯	Blue	White
⑰	Purple	None
⑱	Gray	None
⑲	Orange	Black
⑳	Red	White
㉑	Brown	White
㉒	Pink	Red
㉓	Gray	Red
㉔	Black	White
㉕	White	None

Note) Terminal no. ㉖ is connected to ㉕ inside the connector.

■ D-sub connector/Cable assembly (25 pins)

AXT100 – DS25 – □

Lead Wire Length

Part no.	L dimension
AXT100-DS25-015	1.5 m
AXT100-DS25-030	3 m
AXT100-DS25-050	5 m

When a commercially available connector is required, use a 25 pin female connector conforming to MIL-C24308.

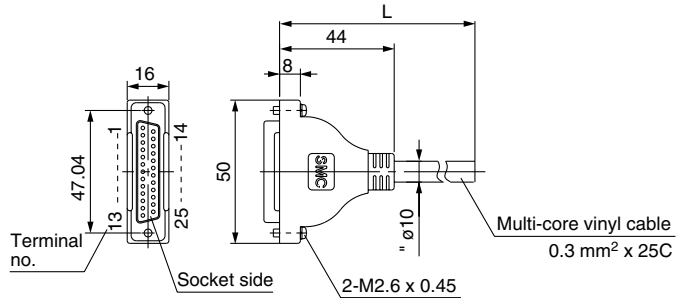

D-sub Connector Cable Assembly Terminal No.

Terminal no.	Lead wire color	Dot marking
①	Black	None
②	Brown	None
③	Red	None
④	Orange	None
⑤	Yellow	None
⑥	Pink	None
⑦	Blue	None
⑧	Purple	White
⑨	Gray	Black
⑩	White	Black
⑪	White	Red
⑫	Yellow	Red
⑬	Orange	Red
⑭	Yellow	Black
⑮	Pink	Black
⑯	Blue	White
⑰	Purple	None
⑱	Gray	None
⑲	Orange	Black
⑳	Red	White
㉑	Brown	White
㉒	Pink	Red
㉓	Gray	Red
㉔	Black	White
㉕	White	None

Circular Connector, D-sub Connector Cable Assembly Electric Characteristics

Item	Characteristics
Conductor resistance W/km, 20°C	65 or less
Withstand voltage VAC, 1 min.	1000
Insulation resistance, M/km, 20°C	5 or less

Note) The minimum inside bending radius for each cable is 20 mm.

VV5QC11

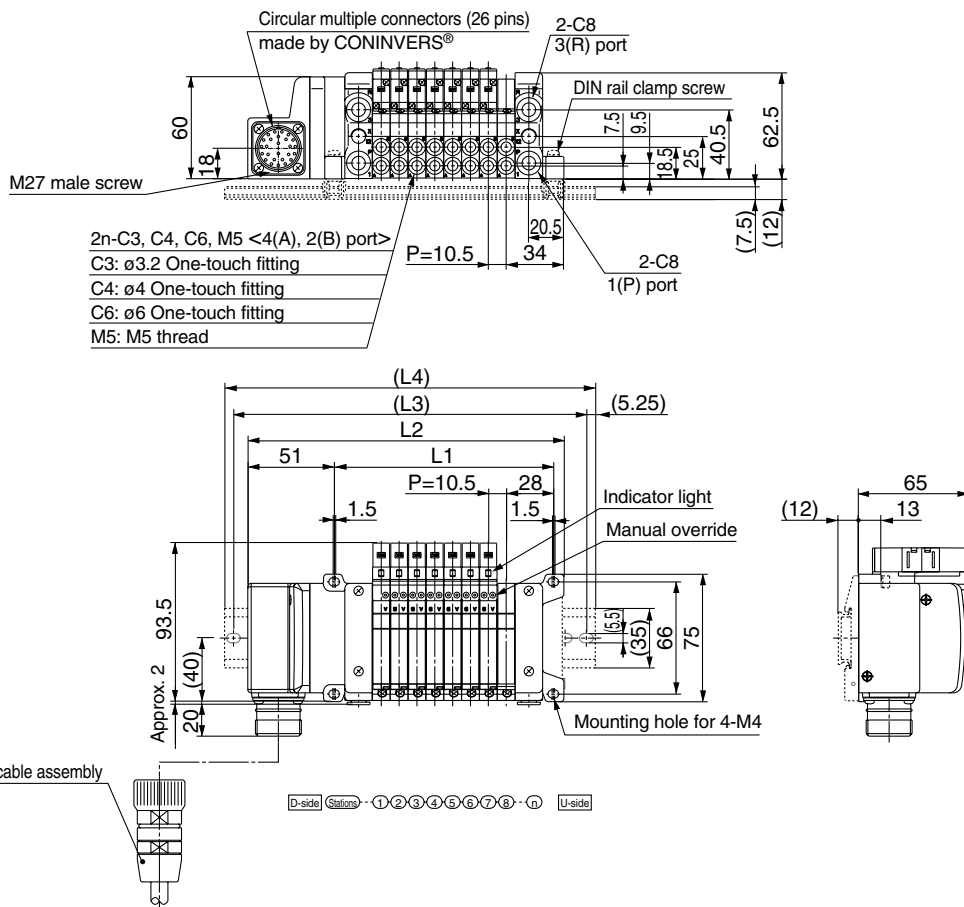

- VQC
- SQ
- VQ0
- VQ4
- VQ5
- VQZ
- VQD

Formulas

$L1 = 10.5n + 45$ (Maximum 24 single wiring stations)

$L2 = 10.5n + 102$

n: Stations

L \ n	1	2	3	4	5	6	7	8	9	10	11	12	13	14	15	16	17	18	19	20	21	22	23	24
L1	55.5	66	76.5	87	97.5	108	118.5	129	139.5	150	160.5	171	181.5	192	202.5	213	223.5	234	244.5	255	265.5	276	286.5	297
L2	112.5	123	133.5	144	154.5	165	175.5	186	196.5	207	217.5	228	238.5	249	259.5	270	280.5	291	301.5	312	322.5	333	343.5	354
L3	137.5	150	162.5	175	175	187.5	200	212.5	225	237.5	237.5	250	262.5	275	287.5	300	300	312.5	325	337.5	350	362.5	375	375
L4	148	160.5	173	185.5	185.5	198	210.5	223	235.5	248	248	260.5	273	285.5	298	310.5	310.5	323	335.5	348	360.5	373	385.5	385.5

* With signal cut block, L4 is obtained by adding approximately 30 mm to L2.

Exploded View of Manifold

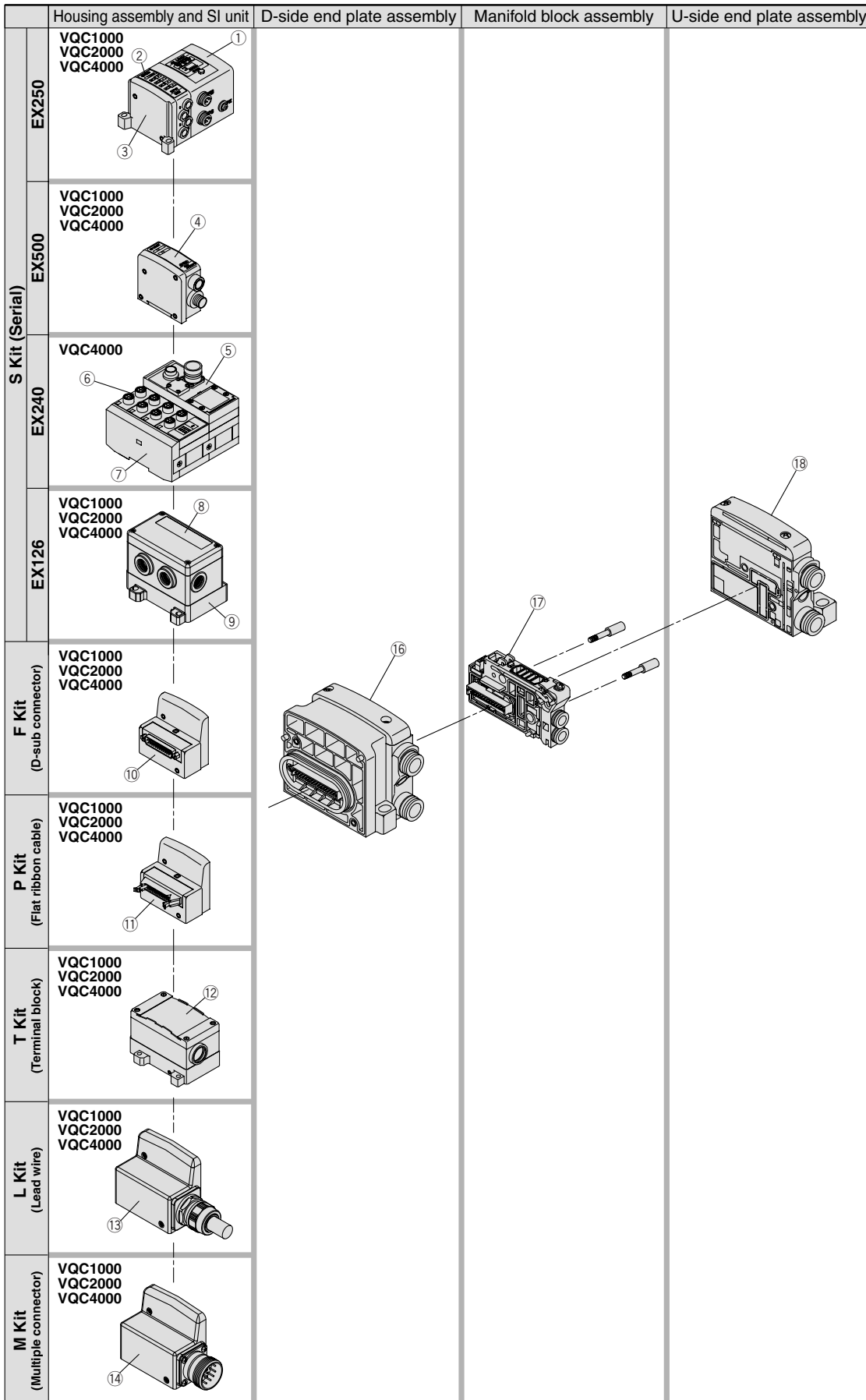

Manifold Assembly Part No.

Housing Assembly and SI Unit/Input Block

No.	Description	Part no.	Note	Applicable model		
				VQC1000	VQC2000	VQC4000
①	SI unit	EX250-SPR1	PROFIBUS-DP (-COM.)	●	●	●
		EX250-SAS□	AS-i (-COM.)	●	●	●
		EX250-SMJ	CC-LINK (+COM.)	●	●	●
		EX250-SDN1	DeviceNet (-COM.)	●	●	●
		EX250-SCA1	CANopen (-COM.)	●	●	●
②	Input block	EX250-IE1	M12, 2 inputs	●	●	●
		EX250-IE2	M12, 4 inputs	●	●	●
		EX250-IE3	M8, 4 inputs	●	●	●
③	End plate assembly	EX250-EA1	Standard	●	●	●
		EX250-EA2	DIN rail mounting	●	●	—
④	SI unit	EX500-Q001	DeviceNet (+COM.)	●	●	●
		EX500-Q001-X1	Remote I/O (+COM.)	●	●	●
		EX500-Q101	DeviceNet / PROFIBUS-DP (-COM.)	●	●	●
		EX500-Q101-X1	Remote I/O (-COM.)	●	●	●
⑤	SI unit	EX240-SDN2	DeviceNet (+COM.)	—	—	●
		EX240-SPR1	PROFIBUS-DP (-COM.)	—	—	●
⑥	Input block	EX240-IE1	M12, 8 inputs	—	—	●
		EX240-EA2	For manifold with input block	—	—	●
⑦	End cover assembly	EX240-EA4	For manifold without input block	—	—	●
		EX126D-SMJ1	CC-LINK (+COM.)	●	●	●
⑧	Terminal plate	VVQC1000-74A-2	For EX126 SI unit mounting	●	●	●
⑩	D-sub connector housing assembly	VVQC1000-F25-1	F kit, 25 pins	●	●	●
⑪	Flat ribbon cable housing assembly	VVQC1000-P26-1	P kit, 26 pins	●	●	●
		VVQC1000-P20-1	P kit, 20 pins	●	●	●
⑫	Terminal block box housing assembly	VVQC1000-T0-1	T kit	●	●	●
⑬	Lead wire housing assembly	VVQC1000-L25-0-1	L kit with 0.6 m lead wire	●	●	●
		VVQC1000-L25-1-1	L kit with 1.5 m lead wire	●	●	●
		VVQC1000-L25-2-1	L kit with 3.0 m lead wire	●	●	●
⑭	Multiple connector housing assembly	VVQC1000-M26-1	M kit 26 pins	●	●	●
⑮	Signal cut block	EX9-SC1-8	Double wiring of 1st to 8th stations	●	●	●
		EX9-SC2-4	Double wiring of 9th to 12th stations	●	●	●

VQC

SQ

VQ0

VQ4

VQ5

VQZ

VQD

D-side end plate assembly

⑮ D-side end plate assembly part no.

VQC1000/2000

VVQC 1 000-3A-1-C8-□

Series	Symbol	VQC1000	VQC2000	Option	Nil	Centralized exhaust
1 VQC1000	C8	●		R	External pilot	
2 VQC2000	C10		●	S	Direct exhaust outlet with built-in silencer	
	N9	●				
	N11		●			

VQC4000

VVQC4000-3A-1-□

Kit type	Thread type
1 S (EX240) kit	Nil Rc
2 F, P, T, S (EX250) kit	F G
3 L, M, S (EX500) kit	T NPT/NPTF

U-side end plate assembly

⑯ U-side end plate assembly part no.

VQC1000/2000

VVQC 1 000-2A-1-C8-□

Series	Port size	Option
1 VQC1000	Symbol	Nil
2 VQC2000	C8	Centralized exhaust
	C10	External pilot
	C12	Direct exhaust outlet with built-in silencer
	N9	
	N11	
	N13	

Supply/Exhaust port entry direction

1	Cylinder port side
2 (Note)	Branch type

Note) VQC2000 only

VQC4000

VVQC4000-2A-1-□

Thread type	Nil	Rc
	F	G
	T	NPT/NPTF

Manifold block assembly

⑰ Manifold block assembly part no.

VVQC 1 000-1A-D-C6-□

Wiring specifications	Option
D Double wiring	Nil None
S Single wiring	B (Note) With back pressure check valve
0 (Note) No wiring	Note) Except VQC4000.
Note) For VQC1000/2000 only.	Thread type (Note)
Series	Nil Rc
1 VQC1000	F G
2 VQC2000	T NPT/NPTF
4 VQC4000	Note) VQC 4000 thread port only
Note) Tie-rods (2 pcs.) for additional stations included.	

Port size

Symbol	Port size	VQC1000	VQC2000	VQC4000
C3	For ø3.2 One-touch fitting	●		
C4	For ø4 One-touch fitting	●	●	
C6	For ø6	●	●	
C8	For ø8		●	●
C10	For ø10			●
C12	For ø12			●
N1	For ø1/8"	●		
N3	For ø5/32"	●	●	
N7	For ø1/4"	●	●	●
N9	For ø5/16"		●	●
N11	For ø3/8"			●
M5	For M5 thread	●		
O2	Rc 1/4"			●
O3	Rc 3/8"			●
B	Rc 1/4" bottom ported			●
C0	Without One-touch fitting	●	●	●

Manifold Specification Sheet

Series VQC1000: Base Mounted/Plug-in Unit

① How to order manifold

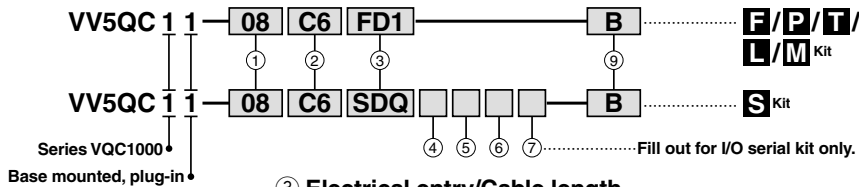

① Stations

01	1 station
⋮	⋮

The maximum number of stations differs depending on the electrical entry. Refer to ③.

② Cylinder port size

C3	With ø3.2 One-touch fitting
C4	With ø4 One-touch fitting
C6	With ø6 One-touch fitting
M5	M5 thread
CM	Mixed sizes and with port plug
L3	Top ported elbow With ø3.2 One-touch fitting
L4	Top ported elbow With ø4 One-touch fitting
L6	Top ported elbow With ø6 One-touch fitting
L5	M5 thread
B3	Bottom ported elbow With ø3.2 One-touch fitting
B4	Bottom ported elbow With ø4 One-touch fitting
B6	Bottom ported elbow With ø6 One-touch fitting
B5	M5 thread
LM	Elbow port, mixed sizes

Note 1) Indicate the size in the specification sheet in the case of CM and LM.

Note 2) Symbols for inch sizes are as follows:

<For One-touch fittings>

- N1: ø1/8"
- N3: ø5/32"
- N7: ø1/4"
- NM: Mixed

The top ported elbow is LN□ and the bottom ported elbow is BN□.

③ Electrical entry/Cable length

	D-side entry	Kit, Cable length	Stations ^{Note 2)}
F Kit	FD0	D-sub connector kit (25P) without cable	1 to 12 (24)
	FD1	D-sub connector kit (25P) with 1.5 m cable	
	FD2	D-sub connector kit (25P) with 3.0 m cable	
P Kit	PD0	Flat ribbon cable kit (26P) without cable	1 to 12 (24)
	PD1	Flat ribbon cable kit (26P) with 1.5 m cable	
	PD2	Flat ribbon cable kit (26P) with 3.0 m cable	
	PD3	Flat ribbon cable kit (26P) with 5.0 m cable	
T Kit	PDC	Flat ribbon cable kit (20P) without cable ^{Note 1)}	1 to 9 (18)
L Kit	LD0	Terminal block box kit	1 to 10 (20)
	LD1	Lead wire kit (25 core) 0.6 m lead wire	1 to 12 (24)
	LD2	Lead wire kit (25 core) 1.5 m lead wire	
LD3	Lead wire kit (25 core) 3.0 m lead wire		
M Kit	MD0	Multiple connector kit (26P) without cable	1 to 12 (24)
	MD1	Multiple connector kit (27P) with 1.5 m cable	
	MD2	Multiple connector kit (27P) with 3.0 m cable	
S Kit	Decentralized wiring serial kit (EX500)		1 to 8 (16)
	SD0A	Serial kit without SI unit	
	SDA1	Serial kit for Remote I/O	
	SDA2		Serial kit for DeviceNet/PROFIBUS-DP/CC-LINK
	Input/Output serial kit (EX250)		1 to 12 (24)
	SD0	Serial kit without SI unit	
	SDQ	Serial kit DeviceNet compatible	
	SDN	Serial kit PROFIBUS-DP compatible	
	SDV	Serial kit CC-LINK compatible	
	SDY	Serial kit CANopen compatible	
	SDTA	AS-i, 8 in/8 out, 31 slave modes, 2 power supply	
	SDTB	AS-i, 4 in/4 out, 31 slave modes, 2 power supply	1 to 2 (4)
	SRTC	AS-i, 8 in/8 out, 31 slave modes, 1 power supply	1 to 4 (8)
SRTD	AS-i, 4 in/4 out, 31 slave modes, 1 power supply	1 to 2 (4)	
Output serial transmission kit (EX126)		1 to 8 (16)	
SDVB	Serial kit CC-LINK compatible		

Note 1) P Kit: Order the cable assembly separately for the type 20P.

Note 2) Numbers inside () indicate the maximum number of solenoids for mixed single and double wiring. The maximum number of stations is determined by the total number of solenoids. In the case of mixed wiring, use the option symbol "-K".

④ SI unit COM.

SI unit COM	EX250					EX500				EX126
	DeviceNet	PROFIBUS-DP	CC-LINK	AS-i	CANopen	DeviceNet	PROFIBUS-DP	CC-LINK	Remote I/O	CC-LINK
Nil	+	+	○	—	—	○	○	○	○	○
N	○	○	—	○	○	○	○	○	○	—

Note) Leave the box blank for the SI unit COM without SI unit (SD0).

⑤ Input block (Fill out for I/O unit only)

Nil	Without SI unit/input block (SD0)
0	Without input block
1	With 1 input block
⋮	⋮
8	With 8 input blocks

⑥ Input block type (Fill out for I/O unit only)

Nil	Without input block
1	M12, 2 inputs
2	M12, 4 inputs
3	M8, 4 inputs (3 pins)

⑦ Input block COM. (Fill out for I/O unit only)

Nil	PNP (+) or without SI unit/input block
N	NPN (-)

⑨ Option

Nil	None
B	All stations with back pressure check valve ^{Note 1)}
D	With DIN rail (Rail length: standard)
D□	With DIN rail (Rail length: special) ^{Note 2)}
K	Special wiring specifications ^{Note 3)} (Except double wiring)
N	With name plate
R	External pilot ^{Note 4)}
S	Direct exhaust with built-in silencer ^{Note 5)}

* When specifying more than one option, enter symbols in alphabetical order. Example: -BRS

Note 1) When using the back pressure check valve for the necessary stations only, enter the back pressure check valve part no. and indicate the number of manifold stations in the specification sheet.

Note 2) For special DIN rail length, indicate "D□." (Enter the number of stations inside □.) Example: -D08

In this case, stations will be mounted on a DIN rail for 8 stations regardless of the actual number of manifold stations. The specified number of stations must be larger than the number of stations on the manifold.

Note 3) Be sure to indicate the wiring specifications in the specification sheet.

Note 4) For external pilot option, "-R", indicate the external pilot specification "R" for the applicable valves as well.

Note 5) The built-in silencer type does not satisfy the IP67 standard.

② How to order applicable valves

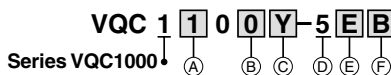

(A) Type of actuation

1	2 position single
2	2 position double
3	3 position closed center
4	3 position exhaust center
5	3 position pressure center
A ^{Note)}	Dual 3 port valve (N.C. + N.C.)
B ^{Note)}	Dual 3 port valve (N.O. + N.O.)
C ^{Note)}	Dual 3 port valve (N.C. + N.O.)

Note) Available for the rubber seal type only.

(B) Seal type

0	Metal seal
1	Rubber seal

(C) Function

Nil	Standard type (1 W)
K ^{Note 1)}	High voltage type (1.0 MPa)
N	Negative COM.
R ^{Note 2)}	External pilot
Y	Low wattage type (0.5 W)

* When specifying more than one option, enter symbols in alphabetical order.

Note 1) Available for the metal seal type only.

Note 2) Not applicable to dual 3 port valve.

(D) Coil voltage

5	24 VDC ^{Note)}
6	12 VDC

Note) S kit is only available for 24 VDC.

(E) Light/Surge voltage suppressor

Nil	With
E	Without ^{Note)}

Note) Not applicable to S kit.

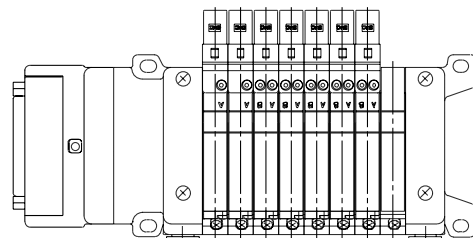

D-side Stations...1...2...3...4...5...6...7...8...n U-side

* Stations are numbered in ascending order from the D-side.

(F) Manual override

Nil	Non-locking push type (Tool required)
B	Slotted locking type (Tool required)
C	Locking type (Manual)
D	Slide locking type (Manual)

Series VQC1000/Plug-in Unit

Manifold model

<F, L, M, P, T kit>



<S kit>



Base mounted, plug-in
 Kit type
 Option
Series VQC1000

Date: / /

Customer name		
Contact person		
Specification sheet no.		
Purchase order no.		
Equipment name		
Quantity	set(s)	Required date

Specifications

← D-side

* Indicate required stations with a "O".

U-side →

Description/Model		Stations	1	2	3	4	5	6	7	8	9	10	11	12	13	14	15	16	17	18	19	20	21	22	23	24
Valves	Single																									
	Double																									
	Closed center																									
	Exhaust center																									
	Pressure center																									
	Dual 3 port valve (A)																									
	Dual 3 port valve (B)																									
	Dual 3 port valve (C)																									
Options	Blanking plate VVQ1000-10A-1																									
	Individual SUP spacer VVQ1000-P-1-C6 SUP shutoff position: Specify 2 positions.																									
	Individual EXH spacer VVQ1000-R-1-C6 EXH shutoff position: Specify 2 positions.																									
	SUP block plate VVQ1000-16A																									
	EXH shutoff position Note 1) (When using EXH block base (VVQC1000-19A-□-C□))																									
Port plug Note 2)			A	B	A	B	A	B	A	B	A	B	A	B	A	B	A	B	A	B	A	B	A	B	A	B
Cylinder port sizes <small>Note 3) Fill out in case of mixed sizes (CM/LM/NM).</small>	With ø3.2 (ø1/8") One-touch fitting	Side ported C3 (N1)																								
	With ø4 (ø5/32") One-touch fitting	Side ported C4 (N3)																								
	With ø6 (ø1/4") One-touch fitting	Side ported C6 (N7)																								
	M5 thread	Side ported M5																								
Dual flow fitting VVQ1000-52A-C8																										
Special wiring Note 4) specifications	Single wiring																									
	Double wiring																									

Description/Model		Stations	1	2	3	4	5	6	7	8	9	10	11	12	13	14	15	16	17	18	19	20	21	22	23	24
Notes	Note 1) Indicate the shutoff position. The D-side of the EXH block in the EXH passage is blocked.																									
	Note 2) When using port plugs, circle ports to specify.																									
	Note 3) When mounting an elbow fitting assembly (VVQ1000-F-L-C ₃ -C ₄), indicate "L C ₃ C ₄ " in the table above.																									
	Note 4) In the case of single wiring or mixed wiring, connections to the connector terminals start from the A-side solenoid of station 1 and continue in order without skip ping any terminals.																									

For SMC use only

Applicable valves and options

Part no.	Qty.

Part no.	Qty.

Order no.	
Clerk (code no.)	
Dept. code	

VQC

SQ

VQ0

VQ4

VQ5

VQZ

VQD