

**5 Port Solenoid Valve
Metal Seal/Rubber Seal
Body Ported**

VQZ1000/2000/3000

Compact design with large flow capacity

Body Width	Cv
10mm	0.2
15mm	0.6
18mm	0.9

Compact design with large flow capacity

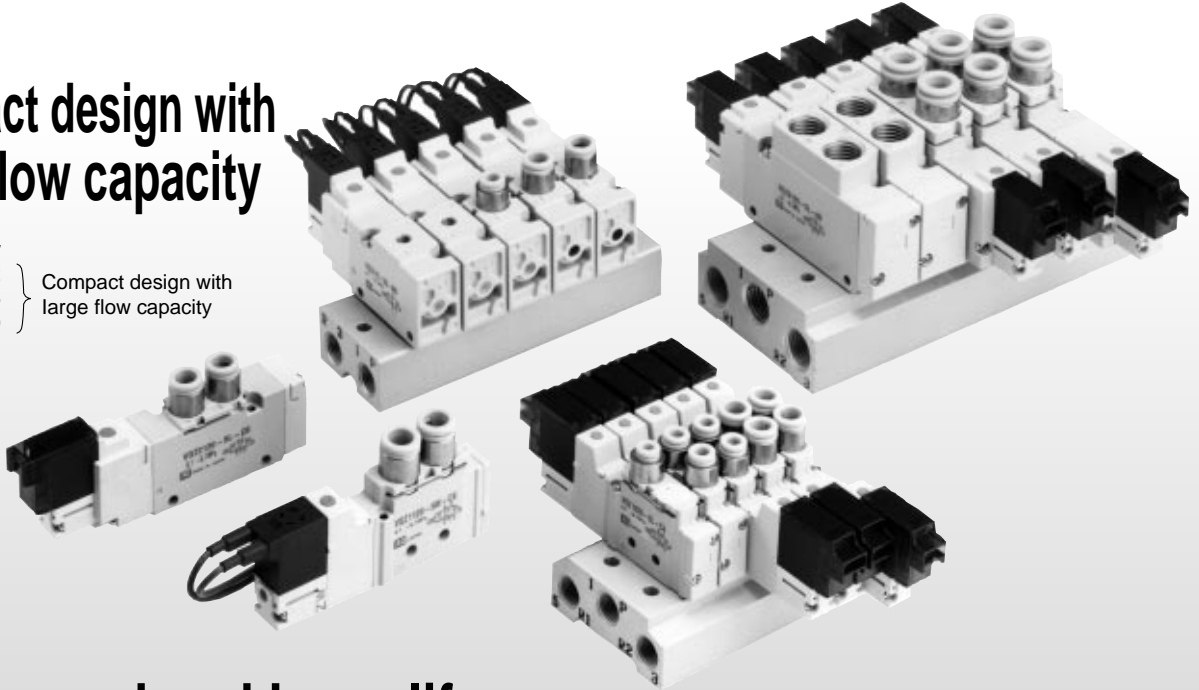

High speed and Long life

	Response time	Life
VQZ1000	10ms	200 million* cycles
VQZ2000	12ms	
VQZ3000	15ms	
Dispersion accuracy		±2ms
*Metal seal, Single solenoid with light and surge voltage suppressor		

Optional IP65 rated model is available with DIN connector.

Built-in One-touch fittings for easier piping

Integral One-touch fittings save on installation time and labor and can be easily removed if necessary.

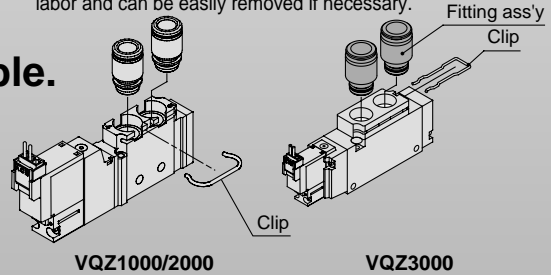

DIN rail mounting is available.

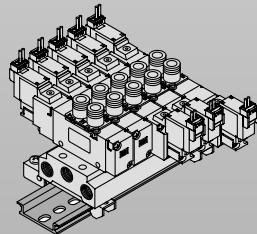

Choice of metal or rubber seal for main valve construction

Both 3 and 5 port valves can be mounted on the same manifold.

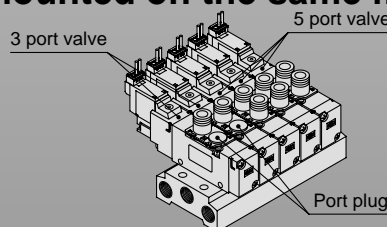

Possible to have all solenoids on same side of manifold



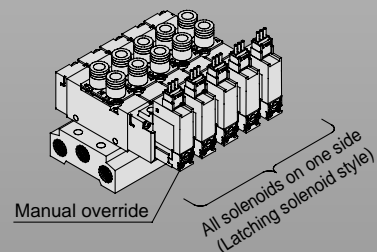







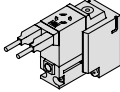

Optional latching coil valve operates the same as a 2 position/double solenoid valve but uses only one solenoid. This saves space and wiring costs.

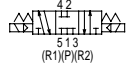
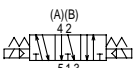
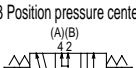

- SY
- SYJ
- SX
- VK
- VZ
- VF
- VFR
- VP7
- VP4
- VQ
- VQ4
- VQZ**
- VQD
- VZS
- VFS
- VS
- VS7

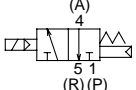
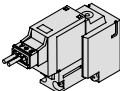
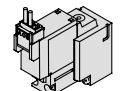
Series VQZ Body Ported

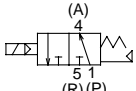
Model Selection

		Cv Metal/Rubber		Function	Voltage	Electrical entry	Light and surge voltage suppressor	Manual override						
Body Ported	5 Port	VQZ1000 	0.15	0.3	2 Position single (A)(B)  5 1 3 (R1)(P)(R2)	(Standard) 12V DC 24V DC (Option) 100V AC 200V AC 110V AC 220V AC	Grommet (G) 	Indicator light and surge voltage suppressor	Non-locking push style (Flush)					
		VQZ2000 	0.45	0.6	2 Position double (A)(B)  5 1 3 (R1)(P)(R2)									
		VQZ3000 	0.7	0.9	3 Position closed center (A)(B)  5 1 3 (R1)(P)(R2) 3 Position exhaust center (A)(B)  5 1 3 (R1)(P)(R2) 3 Position pressure center (A)(B)  5 1 3 (R1)(P)(R2)									
	3 Port for mixture mounting	VQZ1000 	0.15	0.3	 (A) 4 5 1 (R)(P)					(Option) 100V AC 200V AC 110V AC 220V AC	L plug connector (L)  M plug connector (M) 	L plug connector (L) M plug connector (M)	DIN connector (YZ) (Except for VQZ1000)	Locking style (Slotted)
		VQZ2000 	0.45	0.6	N.C.  (A) 4 5 1 (R)(P)									
		VQZ3000 	0.7	0.9	N.O.									

- SY
- SYJ
- SX
- VK
- VZ
- VF
- VFR
- VP7
- VP4
- VQ
- VQ4
- VQZ
- VQD
- VZS
- VFS
- VS
- VS7

Base mounted (With sub-plate)	Cv	Cylinder speed (mm/s)	Bore size (mm)															
			Series CJ2			Series CM2				Series CA1								
			ø6	ø10	ø16	ø20	ø25	ø32	ø40	ø40	ø50	ø63	ø80	ø100				
VQZ1000 Body width 10	0.3	150																
		300																
		450	●															
		600		●	●													
		750																
VQZ2000 Body width 15	0.6	150																
		300																
		450	●															
		600		●	●													
		750																
VQZ3000 Body width 18	0.9	150																
		300																
		450	●					●	●									
		600		●	●													
		750																

Cylinder speed marked with "●" can be controlled by speed controller. (Pressure: 0.5MPa, Load rate: 50%)

⚠ Precautions

Be sure to read before handling. Refer to p.0-33 to 0-36 for Safety Instructions and common precautions.

⚠ Warning

Manual Override

Without an electric signal for the solenoid valve the manual override is used for switching the main valve.

Non-locking push style (Flush)

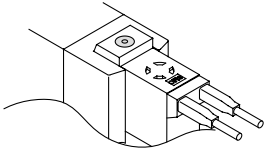

Push down on the manual override button with a small screwdriver until it stops. Release the screwdriver and the manual override will return.

Locking style (Slotted)

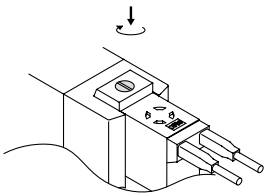

Push down on the manual override button with a small screwdriver until it stops. While down, turn clockwise by 90° to lock it. Turn it counterclockwise to release it.

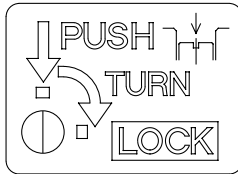

⚠ Caution

How to Use L and M Plug Connector

Insertion/Removal of connector

M plug connector

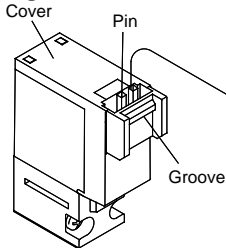

Insertion:
Push the connector straight onto the pins of the solenoid, making sure the lip of the lever securely "locks" into the groove of the solenoid cover.

Removal:
Press the lever against the connector housing and pull it outward from the solenoid.

L plug connector

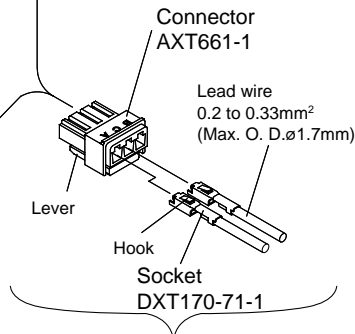
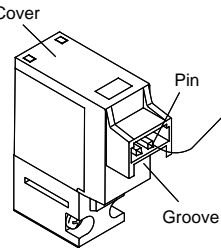

Refer to p.1.12-28 for part no. of plug connector ass'y.

Connection and Electrical Circuit

The VQZ series features non-polar solenoids.

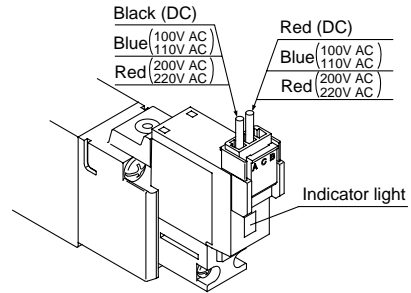

With light and surge voltage suppressor

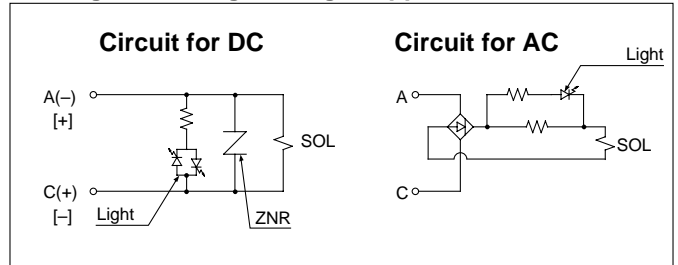

Due to the use of non-polar light, the VQZ series has no polarity. Refer to p.1.12-26 for latching style.

Connection of Lead Wire (Not necessary if ordering lead wire pre-connected model.)

Crimping connection of lead wire and socket

Strip 3.2 to 3.7mm of the lead wire ends, insert each stripped wire into a socket and crimp contact it using special crimping tool. Be careful that the outer insulation of the lead wires does not interfere with the socket contact part.

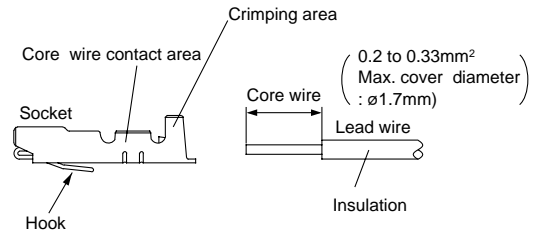

Tool for crimping: Model No. DXT170-75-1

Connection/Disconnection of socket with lead wire

Connection
Insert lead wire and crimped socket into square holes (indicated as A,B, COM) of connector. Press the socket in fully until the hook of the socket locks into the groove of the connector housing. Confirm the locked position by lightly pulling on the lead wire.

Disconnection

To remove the socket from the connector, pull out lead wire while depressing the hook of the socket with a fine screw driver (or similar). If the socket is to be re-used, reposition the hook again.

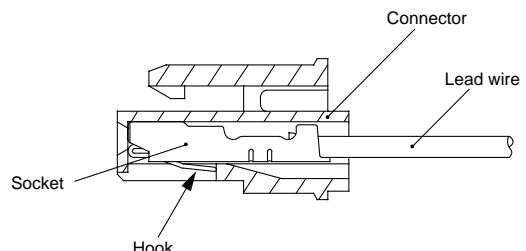

How to Wire the DIN Connector

Conforming to ISO#: DIN 43650 C (8mm between pins)
Cut the power and air supply before mounting/removing the connector.

- ① Loosen the top screw and remove the connector housing from the terminal spades on the solenoid.
- ② Remove the housing screw and insert a screwdriver into the slot area on the underside of the DIN cap and carefully separate block and housing.
- ③ Loosen the terminal screws of the block and insert stripped lead wires in accordance with the wiring diagram. Secure each wire by retightening the terminal screw.
- ④ Tighten the housing grommet nut to secure the cable wire.

Change of electrical entry (orientation)

Once the housing is separated from the terminal block, it can be rotated in any direction to change the orientation of the electrical entry.

* In the case of the indicator light option, avoid damaging the light with the lead wire connections.

Precaution

Pull connector out vertically, never at an angle.

Applicable cable

Cord O. D.: $\phi 3.5$ to $\phi 7$

(Reference) 0.5mm² 2-core and 3-core wires equivalent to JISC3306.

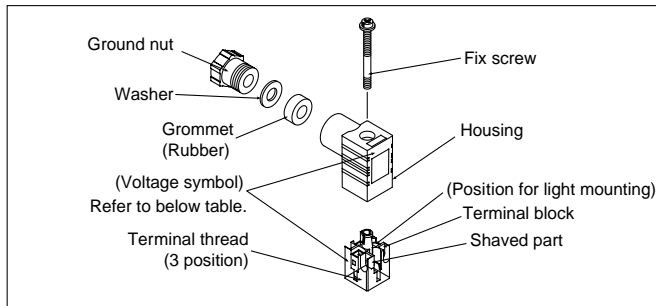

Part No. of DIN Connector (Based on DIN)

Without light		AXT100-20-1
With light		
Rated voltage	Voltage symbol	Part No.
24V DC	24V	AXT100-20-2-05
12V DC	12V	AXT100-20-2-06
100V AC	100V	AXT100-20-2-01
200V AC	200V	AXT100-20-2-02
110V AC	110V	AXT100-20-2-03
220V AC	220V	AXT100-20-2-04

Circuit with light

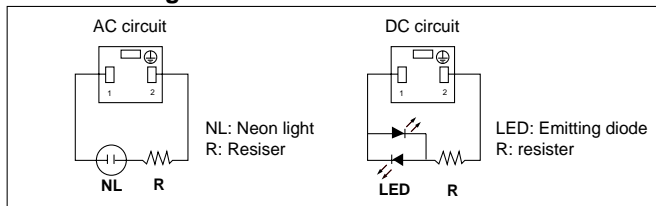

Fitting and Silencer Part No. for P, R Ports When Using Valve as an Individual Unit

Series	One-touch fitting for 1(P) port	Silencer for 3(R2, R), 5(R1)	
		Silencer	One-touch fitting
VQZ1000	KQH06-M5	AN120-M5	KJSO4-M5
VQZ2000	KQH06-01S	INA-25-46	IN-457-32 (for $\phi 6$)
VQZ3000	KQH08-02S	AN101-01	KQH06-01S

The diameter of the above fitting and silencer is the maximum diameter to be installed correctly.

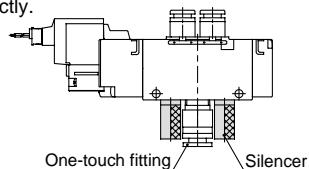

Mounting 3 Port Valves on 5 Port Manifolds (VQZ $\frac{1}{2}$ 82 $\frac{1}{2}$, N.C./VQZ $\frac{1}{2}$ 92 $\frac{1}{2}$, N.O.)

When a 3 port valve is mounted on a 5 port manifold, the "A" port is the working port, port plug is installed in the B port.

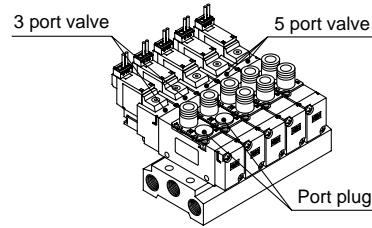

Changing the One-touch Fittings

The built-in fittings on the manifold can be changed easily. Simply remove the corresponding valve and take out the fitting clip underneath. Then remove the affected fitting and replace with a new one. Finally, replace the fitting clip and remount the valve.

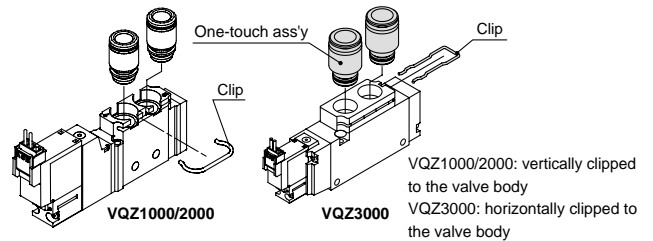

Precaution

When pulling the fitting ass'y away from the valve base, remove the clip, then connect a tube or plug (KQP-□□) with the One-touch fitting and pull it out holding the tube or plug. Do not hold the release bushing to avoid damage.

DIN Rail Removal/Mounting

To remove manifold from DIN rail:

- 1) Loosen the clamp screw on the "A" side of both ends of the manifold.
- 2) Lift the "A" side of the manifold off the DIN rail and slide it in the direction of the "B" side.

Mounting manifold to DIN rail:

- 1) Catch the hook of the DIN rail bracket on the "B" side on the DIN rail.
- 2) Push side "A" onto the DIN rail and tighten the clamp screw. (Tightening torque of 0.3 to 0.4 Nm)

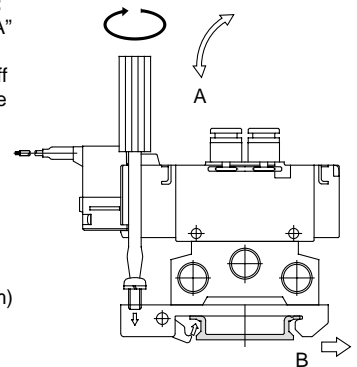

Valve Mounting

After confirming the gasket is correctly placed under the valve, tighten the mounting screws with the appropriate torque listed below.

Model	Suitable tightening torque
VQZ1000	0.18 to 0.25Nm
VQZ2000	0.25 to 0.35Nm
VQZ3000	0.5 to 0.7Nm

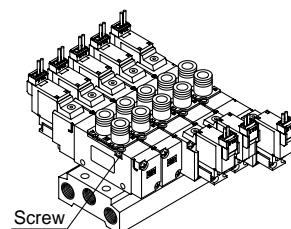

SY

SYJ

SX

VK

VZ

VF

VFR

VP7

VP4

VQ

VQ4

VQZ

VQD

VZS

VFS

VS

VS7

Body Ported

Plug Lead Unit

5 Port Solenoid Valve

VQZ1000/2000/3000

Single Unit

How to Order Valve

VQZ **1** **1** **2** **1** **—** **5** **M** **—** **C6** **—** **—**

Series

1	VQZ1000 Body width 10mm
2	VQZ2000 Body width 15mm
3	VQZ3000 Body width 18mm

Configuration

1	2 position single	
2	2 position double	 Metal Rubber
3	3 position closed center	
4	3 position exhaust center	
5*	3 position pressure center	

* Except VQZ1000 and metal seal style.

Body

2	Body ported
---	-------------

Seal

0	Metal seal
1	Rubber seal

Function

Symbol	Specification	DC	AC
—	Standard	(1.0W) ○	○ ⁽³⁾
K ⁽¹⁾	High pressure (Metal seal)	(1.0W) ○	—
Y	Low wattage	(0.5W) ○	—
R ⁽²⁾	External pilot	○	○

Note 1) Option
 Note 2) Refer to p.1.12-27 for details about external pilot specification except VQZ1000.
 Note 3) Refer to p.1.12-7 for power consumption of AC type.
 Note 4) When specifying more than one option, indicate them alphabetically.

Bracket

—	None
F	With bracket (Applicable to single)

Port size [4(A), 2(B) port]

Symbol	Port size	VQZ1000	VQZ2000	VQZ3000
C3	One-touch fitting for ø3.2	○	—	—
C4	One-touch fitting for ø4	○	○	—
C6	One-touch fitting for ø6	○	○	○
C8	One-touch fitting for ø8	—	—	○
C10	One-touch fitting for ø10	—	—	○
M5	M5 thread	○	○	—
O2	Rc(PT)1/4	—	—	○

Note 1) Refer to p.1.12-27 for inch size and One-touch fitting.

Manual override

—: Non-locking push style (Flush) B: Locking style (Slotted)

Electrical entry

G: Grommet (DC spec.)	L: L plug connector with lead wire	LO: L plug terminal without lead wire	M: M plug connector with lead wire	MO: M plug terminal without lead wire
	With light and surge voltage suppressor	With light and surge voltage suppressor	With light and surge voltage suppressor	With light and surge voltage suppressor
Y: DIN connector	YO: DIN terminal without connector	YZ: DIN ⁽¹⁾ connector	YOS: DIN ⁽¹⁾ terminal without connector	
		With light and surge voltage suppressor	With surge voltage suppressor	

Note 1) DIN is suitable for VQZ2000, 3000.
 Note 2) Standard lead wire length: 300mm

Coil voltage

1*	100V AC (50/60Hz)
2*	200V AC (50/60Hz)
3*	110V AC (50/60Hz)
4*	220V AC (50/60Hz)
5	24V DC
6	12V DC
9*	Others

* When requiring AC specifications or special voltage, consult SMC.

VQZ1000/2000/3000 Body Ported

Standard Specifications



Valve specifications	Seal	Metal seal	Rubber seal	
	Fluid	Air, Inert gas	Air, Inert gas	
	Max. operating pressure	0.7MPa (High pressure type: 1.0MPa)		
	Max. operating pressure	2 position	0.1MPa only for VQZ3000, 3 position	0.15MPa
		3 position		0.2MPa
	Ambient and fluid temperature	-10 to 50°C ⁽¹⁾		
	Max. operating frequency	2 position	20Hz	5Hz
		3 position	10Hz	3Hz
	Pilot valve EXH	Individual EXH		
	Lubrication	Not required		
Manual override	Non-locking push / Locking slotted styles			
Shock/Vibration resistance ⁽²⁾	150/30 m/s ²			
Enclosure	Dust proof			
Solenoid specifications	Coil rated voltage	12V, 24V DC and 100V, 110V, 200V, 220V AC		
	Allowable voltage	±10% of rated voltage		
	Coil insurance	Class B		
	Power consumption (Current value)	24V DC	1W DC (42mA), 0.5W DC (21mA)	
		12V DC	1W DC (83mA), 0.5W DC (42mA)	
		100V AC	Inrush 0.5VA (5mA), Holding 0.5VA (5mA)	
		110V AC	Inrush 0.55VA (5mA), Holding 0.55VA (5mA)	
200V AC		Inrush 1.0VA (5mA), Holding 1.0VA (5mA)		
220V AC	Inrush 1.1VA (5mA), Holding 1.1VA (5mA)			

Note 1) Use dry air to prevent condensation when operating at low temperatures.
 Note 2) Shock resistance... No malfunctions resulted from the impact test using a drop impact tester. The test was performed on the axis and right angle direction of the main valve and armature, for both energized and de-energized states. (Value in the initial stage.)
 Vibration resistance... No malfunction occurred in a one-sweep test between 8.3 and 2,000 Hz. Test was performed at both energize and de-energized states to the axis and right angle direction of the main valve and armature. (Value in the initial stage.)

Model

Series	Configuration	Model	Effective area (mm ²)(Cv)	Response time (ms) ⁽²⁾		Weight (g) ⁽³⁾		
				Standard: 1W High pressure: 1.5W	High pressure: 1W Low wattage and AC			
VQZ1000	2 position	Single	Metal seal	VQZ1120	2.7 (0.15)	12 or less	15 or less	42
			Rubber seal	VQZ1121	5.4 (0.3)	12 or less	15 or less	
	Double	Metal seal	VQZ1220	2.7 (0.15)	10 or less	13 or less		
		Rubber seal	VQZ1221	5.4 (0.3)	10 or less	13 or less		
	3 position	Closed center	Metal seal	VQZ1320	2.0 (0.11)	20 or less	26 or less	61
			Rubber seal	VQZ1321	3.1 (0.17)	25 or less	33 or less	
Exhaust center		Metal seal	VQZ1420	2.7 (0.15)	20 or less	26 or less		
		Rubber seal	VQZ1421	5.4 (0.3)	25 or less	33 or less		
Pressure center	Rubber seal	VQZ1521	3.1 (0.17)	25 or less	33 or less			
VQZ2000	2 position	Single	Metal seal	VQZ2120	8.1 (0.45)	14 or less	18 or less	64
			Rubber seal	VQZ2121	10.8 (0.6)	15 or less	20 or less	
		Double	Metal seal	VQZ2220	8.1 (0.45)	10 or less	13 or less	
			Rubber seal	VQZ2221	10.8 (0.6)	12 or less	15 or less	
	3 position	Closed center	Metal seal	VQZ2320	6.3 (0.35)	23 or less	30 or less	88
			Rubber seal	VQZ2321	8.1 (0.45)	25 or less	33 or less	
		Exhaust center	Metal seal	VQZ2420	8.1 (0.45)	23 or less	30 or less	
			Rubber seal	VQZ2421	10.8 (0.6)	25 or less	33 or less	
Pressure center	Metal seal	VQZ2520	6.3 (0.35)	23 or less	30 or less			
	Rubber seal	VQZ2521	8.1 (0.45)	25 or less	33 or less			
VQZ3000	2 position	Single	Metal seal	VQZ3120	12.6 (0.7)	17 or less	22 or less	109
			Rubber seal	VQZ3121	16.2 (0.9)	25 or less	33 or less	
		Double	Metal seal	VQZ3220	12.6 (0.7)	10 or less	13 or less	
			Rubber seal	VQZ3221	16.2 (0.9)	15 or less	20 or less	
	3 position	Closed center	Metal seal	VQZ3320	10.8 (0.6)	25 or less	33 or less	134
			Rubber seal	VQZ3321	12.6 (0.7)	30 or less	39 or less	
		Exhaust center	Metal seal	VQZ3420	12.6 (0.7)	25 or less	33 or less	
			Rubber seal	VQZ3421	16.2 (0.9)	30 or less	39 or less	
		Pressure center	Metal seal	VQZ3520	10.8 (0.6)	25 or less	33 or less	
			Rubber seal	VQZ3521	12.6 (0.7)	30 or less	39 or less	

Note 1) Value for sub-plate and maximum diameter
 Note 2) As per JISB8375-1981 (Supply pressure; 0.5MPa ; with indicator light and surge voltage suppressor; clean air)
 The response time is subject to the pressure and the air quality. The values at the time of ON are given for double styles.
 Note 3) Weight without sub-plate

- SY
- SYJ
- SX
- VK
- VZ
- VF
- VFR
- VP7
- VP4
- VQ
- VQ4
- VQZ
- VQD
- VZS
- VFS
- VS
- VS7

VQZ1000/2000/3000 Body Ported

Construction: VQZ1000/2000/3000

Metal seal

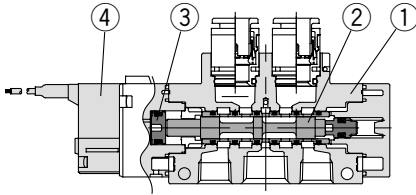

2 position single

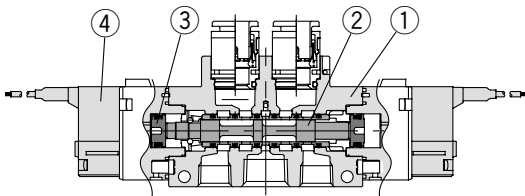
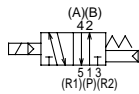

2 position double

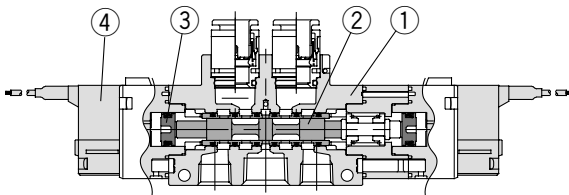
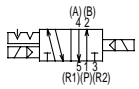

3 position closed center

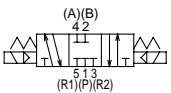

3 position exhaust center

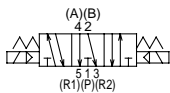

3 position pressure center ⁽¹⁾

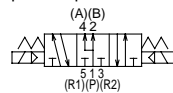

Note 1) Except VQZ1000 and metal seal.

Rubber seal

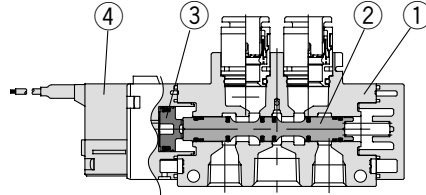

2 position single

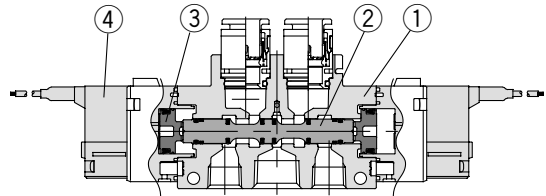
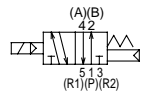

2 position double

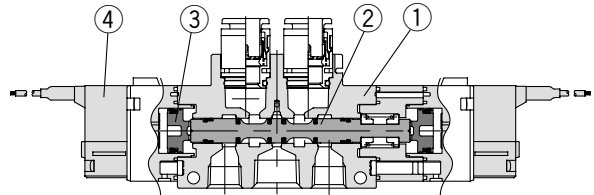
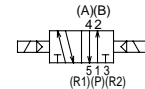

3 position closed center



3 position exhaust center

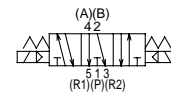

3 position pressure center

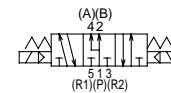

Component Parts

No.	Description	Material	Note
①	Body	Aluminum die cast	
②	Spool/Sleeve	Stainless steel	Metal seal
②	Spool valve	Aluminum/NBR	Rubber seal
③	Piston	Resin	
④	Pilot valve	—	

Dimensions: VQZ1000

2 position single

Grommet (G): VQZ112⁰₁-□G□-C3, C4, C6, M5

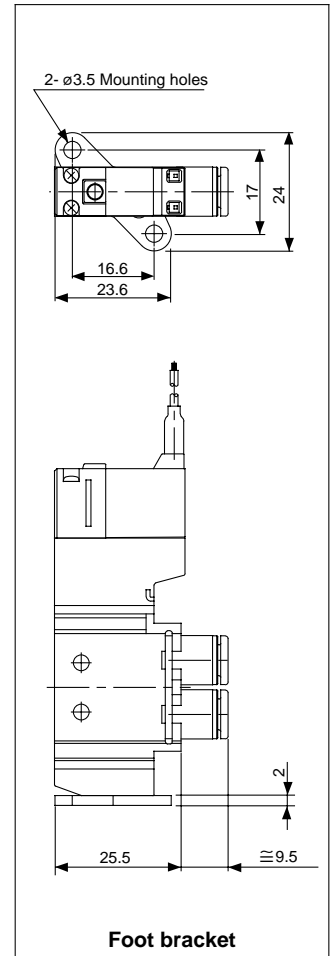
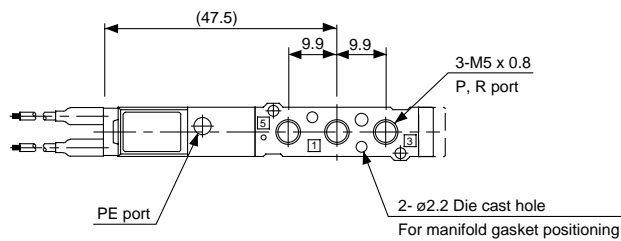
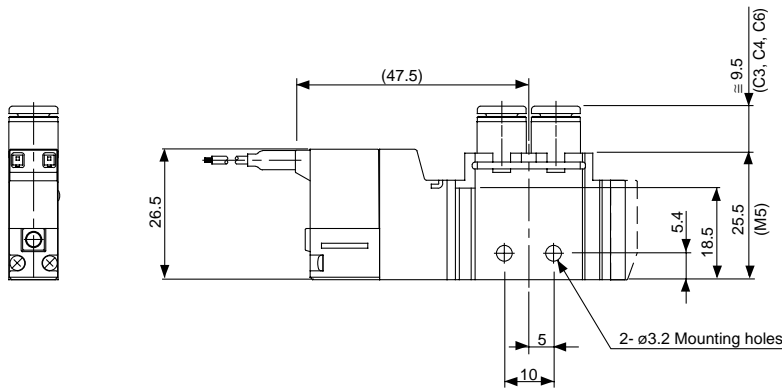
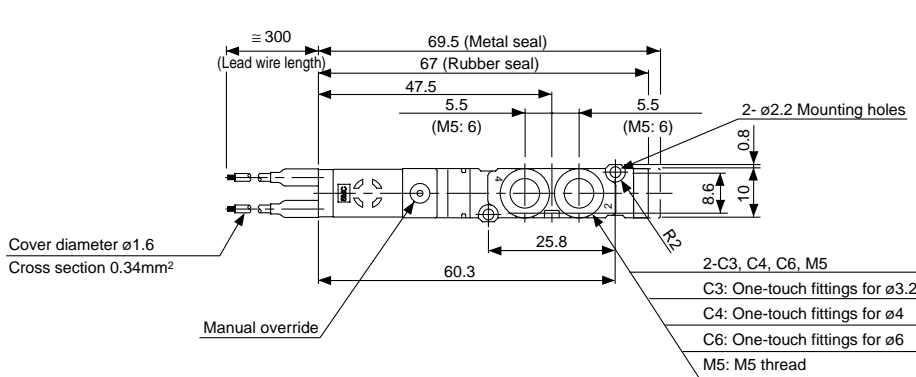

- SY
- SYJ
- SX
- VK
- VZ
- VF
- VFR
- VP7
- VP4
- VQ
- VQ4
- VQZ**
- VQD
- VZS
- VFS
- VS
- VS7

L plug connector (L): VQZ112⁰₁-□L□-C3, C4, C6, M5

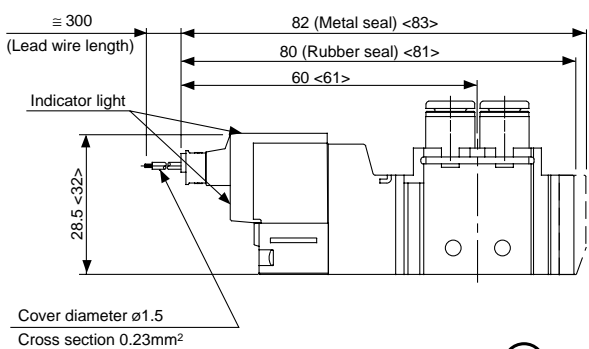

M plug connector (M): VQZ112⁰₁-□M□-C3, C4, C6, M5

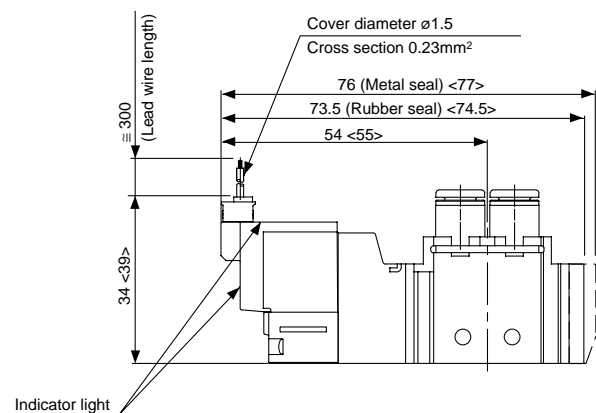

VQZ1000/2000/3000 Body Ported

Dimensions: VQZ1000

2 position double

Grommet (G): VQZ122⁰₁-□G□-C3, C4, C6, M5

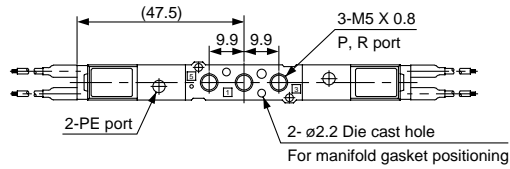
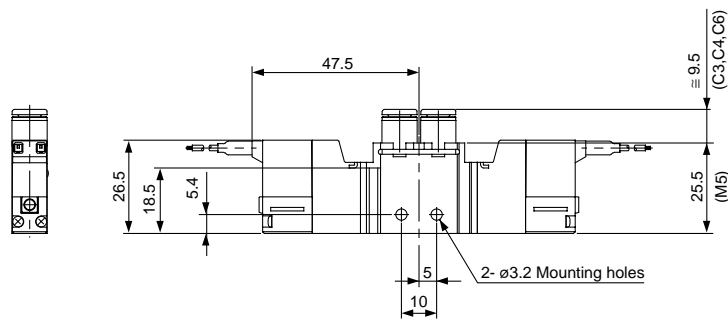
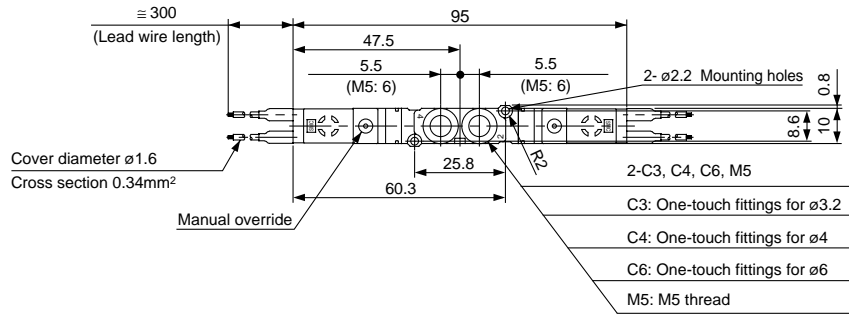

L plug connector (L): VQZ122⁰₁-□L□-C3, C4, C6, M5

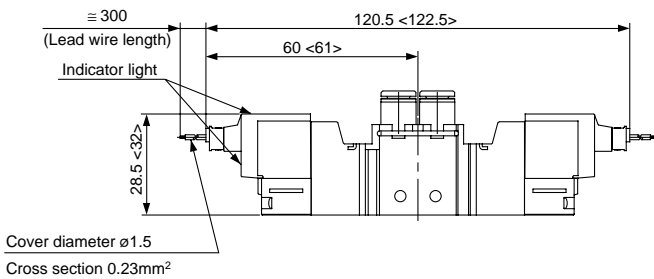

M plug connector (M): VQZ122⁰₁-□M□-C3, C4, C6, M5

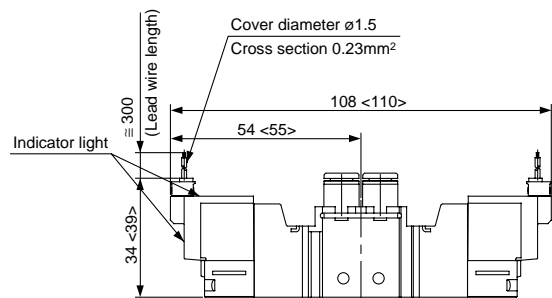

VQZ1000

3 position closed center/exhaust center/pressure center (except for metal seal)

Grommet (G): VQZ1³₄2⁰₁-□G□-C3, C4, C6, M5

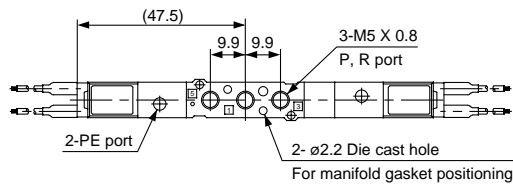
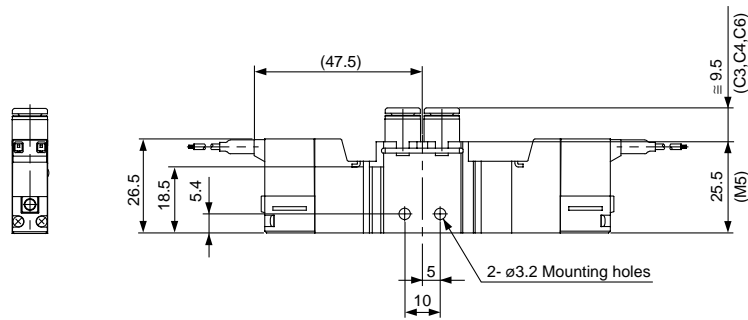
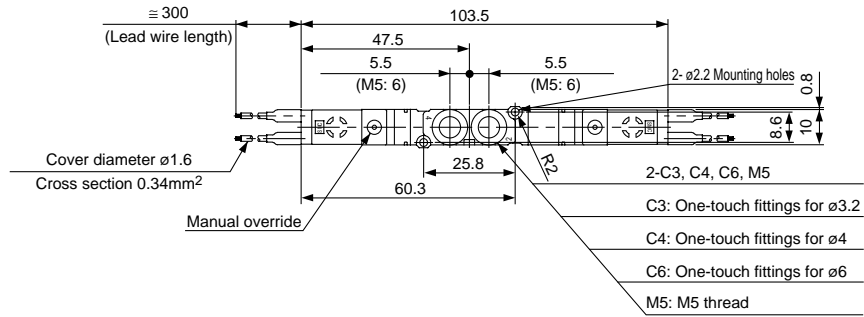

L plug connector (L): VQZ1³₄2⁰₁-□L□-C3, C4, C6, M5

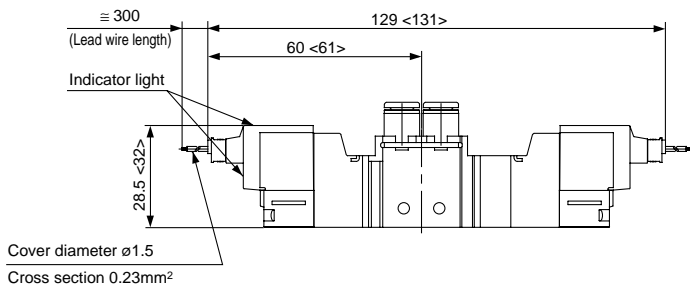

M plug connector (M): VQZ1³₄2⁰₁-□M□-C3, C4, C6, M5

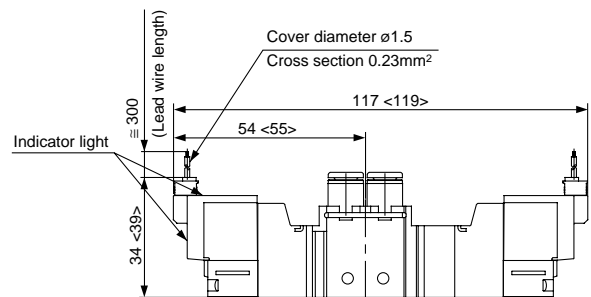

- SY
- SYJ
- SX
- VK
- VZ
- VF
- VFR
- VP7
- VP4
- VQ
- VQ4
- VQZ
- VQD
- VZS
- VFS
- VS
- VS7

VQZ1000/2000/3000 Body Ported

Dimensions: VQZ2000

2 position single

Grommet (G): VQZ212⁰₁(R)-□G□-C4, C6, M5

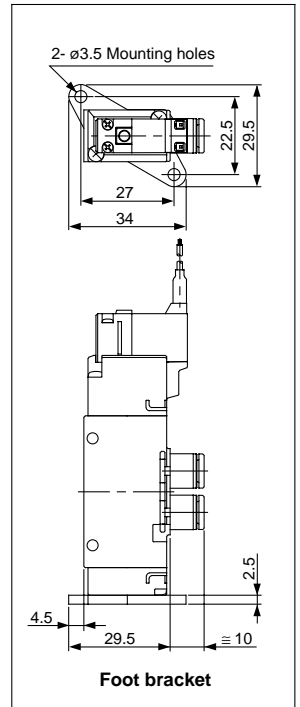
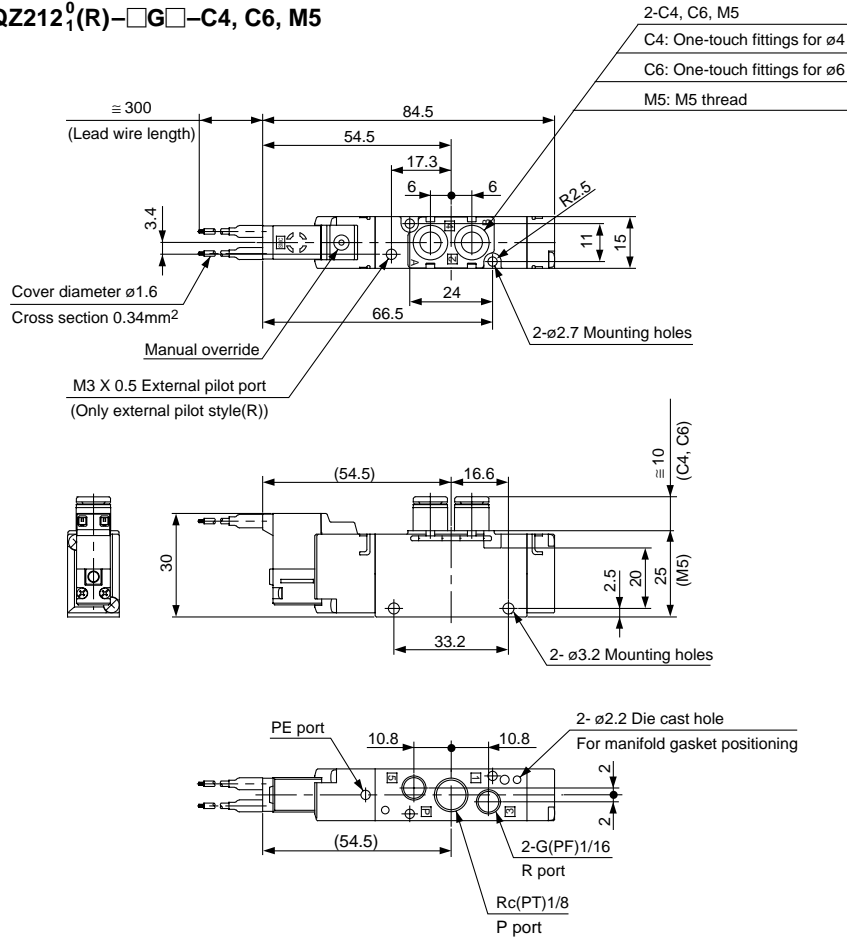

L plug connector (L): VQZ212⁰₁(R)-□L□-C4, C6, M5

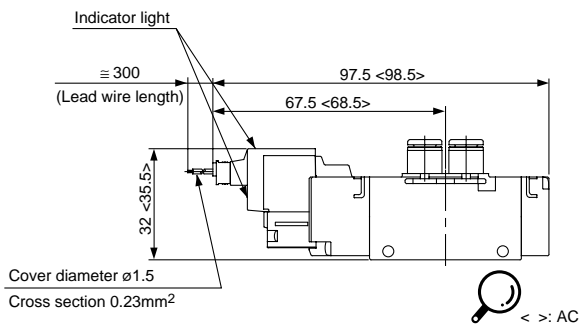

DIN connector (Y): VQZ212⁰₁(R)-□Y□-C4, C6, M5

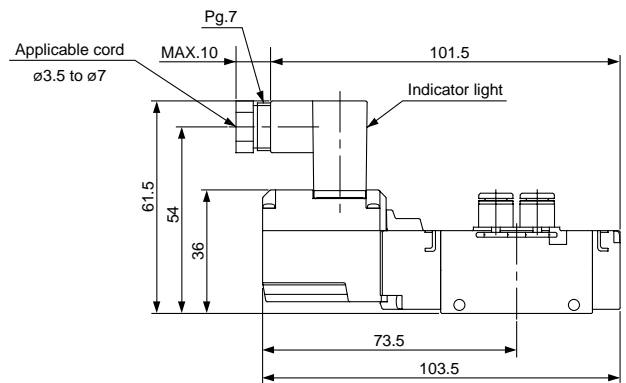

M plug connector (M): VQZ212⁰₁(R)-□M□-C4, C6, M5

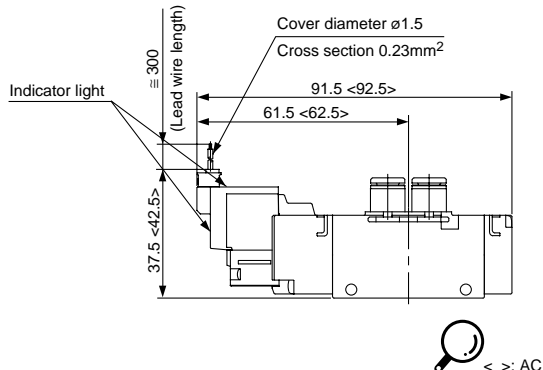

VQZ2000

2 position double

Grommet (G): VQZ222₁⁰(R)-□G□-C4, C6, M5

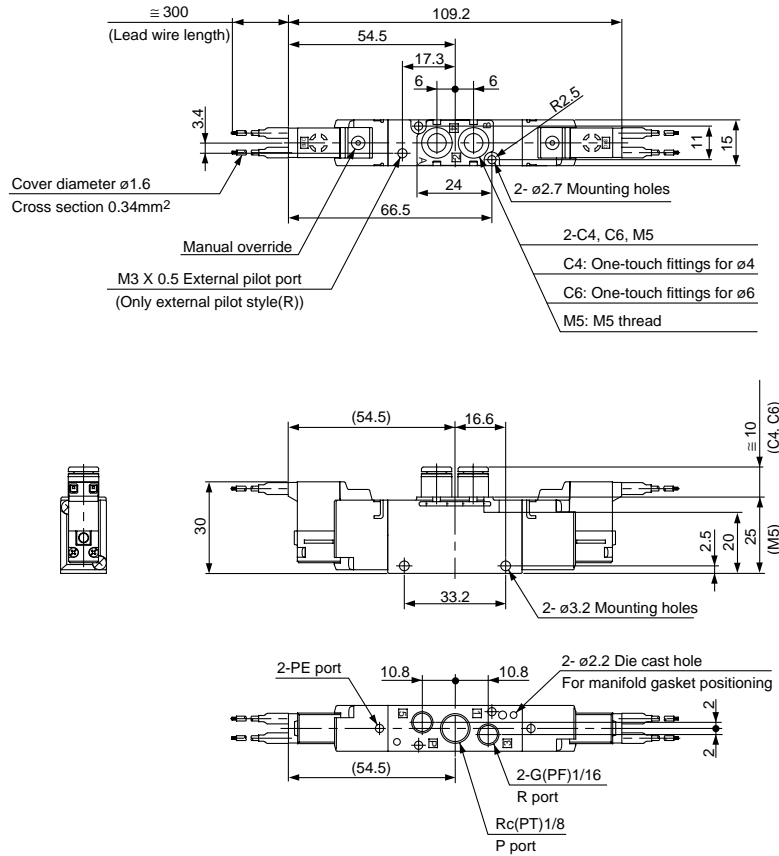

- SY
- SYJ
- SX
- VK
- VZ
- VF
- VFR
- VP7
- VP4

- VQ
- VQ4
- VQZ
- VQD
- VZS
- VFS
- VS
- VS7

L plug connector (L): VQZ222₁⁰(R)-□L□-C4, C6, M5

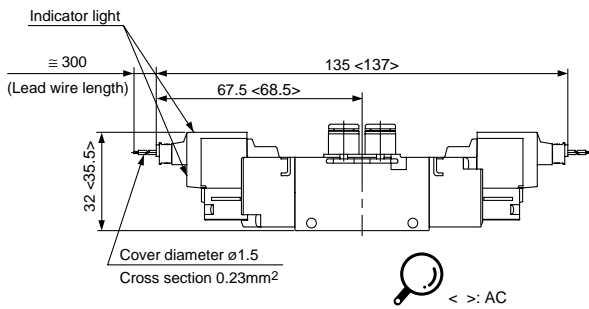

DIN connector (Y): VQZ222₁⁰(R)-□Y□-C4, C6, M5

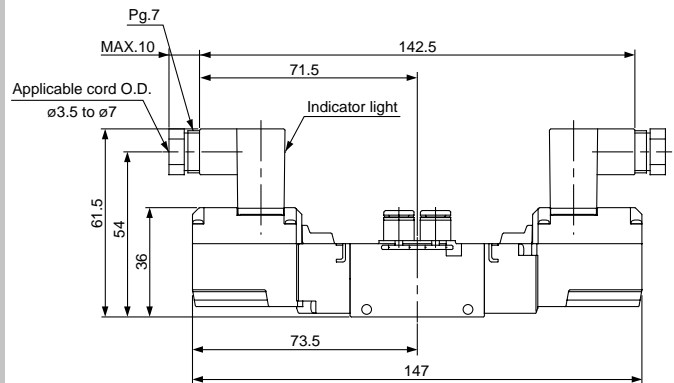

M plug connector (M): VQZ222₁⁰(R)-□M□-C4, C6, M5

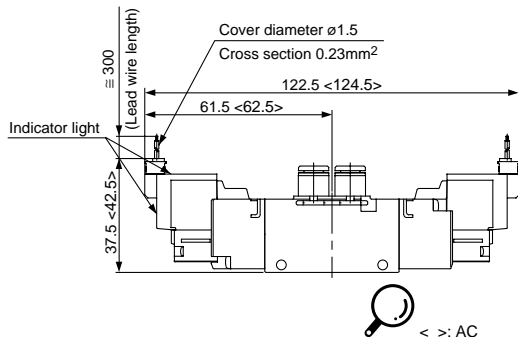

VQZ1000/2000/3000 Body Ported

Dimensions: VQZ2000

3 position closed center/exhaust center/pressure center

Grommet (G): VQZ2³₄2⁰₁(R)-□G□-C4, C6, M5

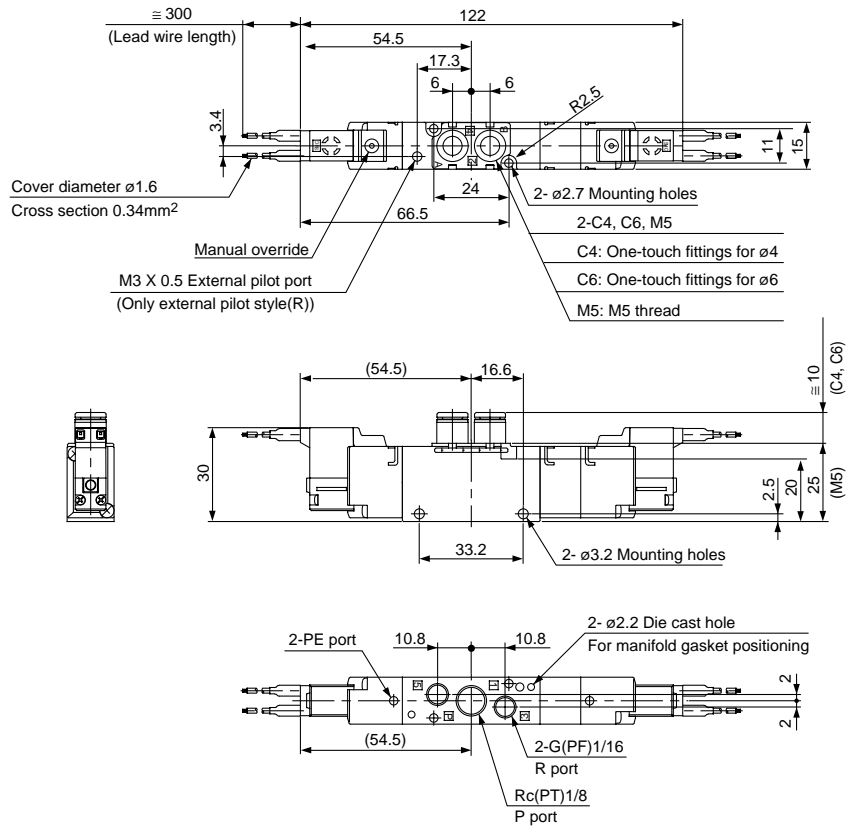

L plug connector (L): VQZ2³₄2⁰₁(R)-□L□-C4, C6, M5

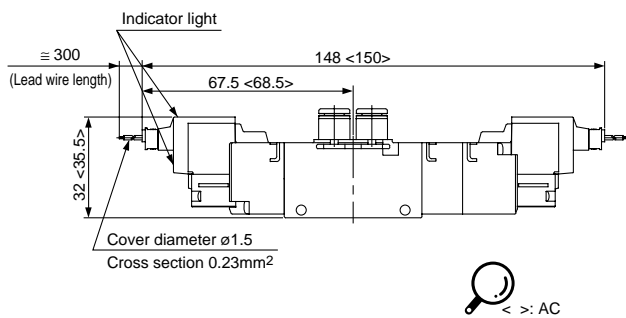

DIN connector (Y): VQZ2³₄2⁰₁(R)-□Y□-C4, C6, M5

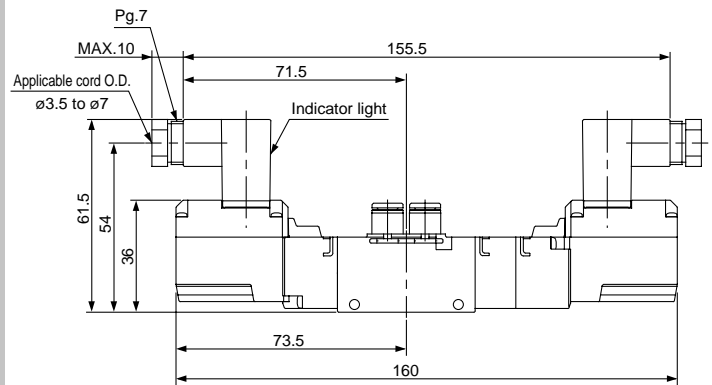

M plug connector (M): VQZ2³₄2⁰₁(R)-□M□-C4, C6, M5

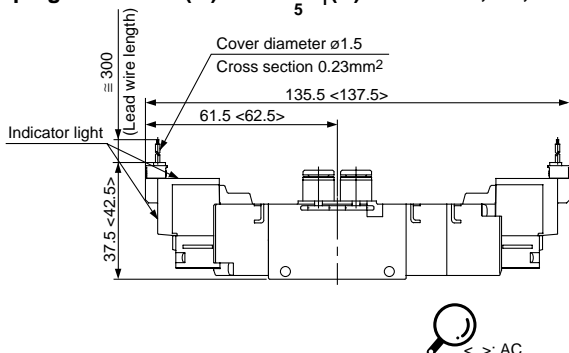

VQZ3000

2 position single

Grommet (G): VQZ312⁰₁(R)-□G□-C6, C8, C10, 02

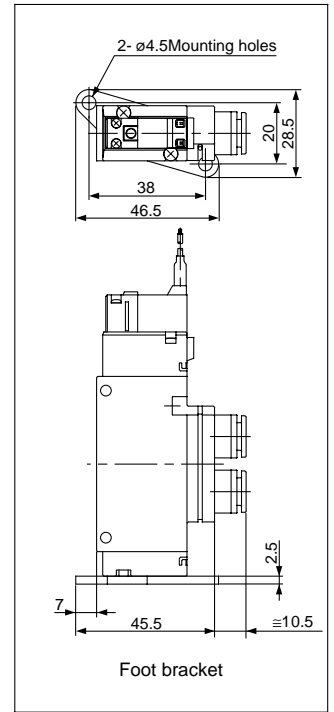
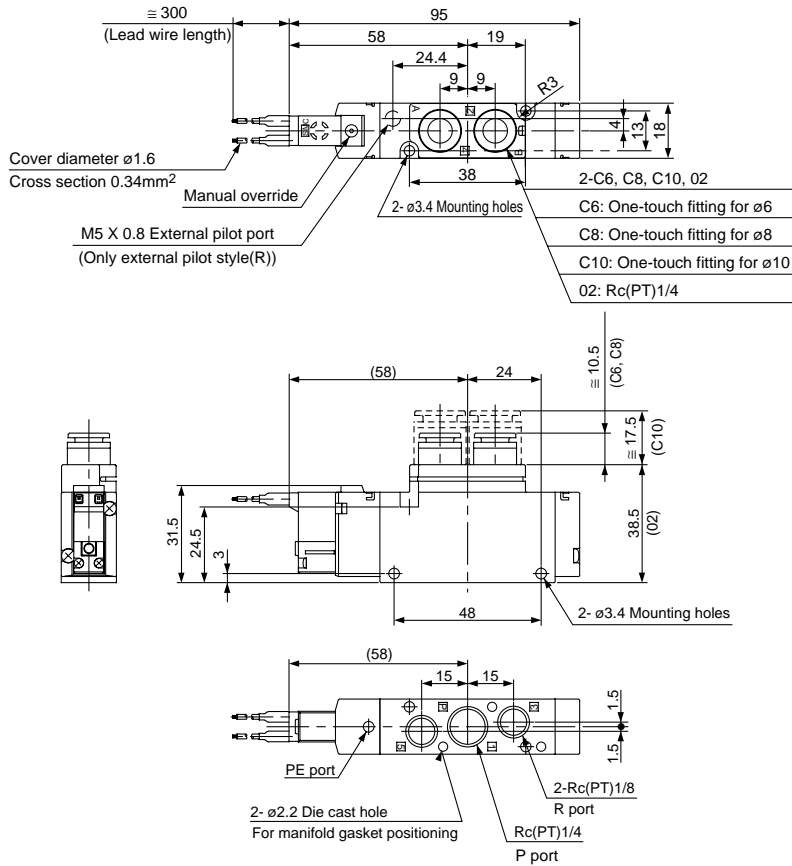

- SY
- SYJ
- SX
- VK
- VZ
- VF
- VFR
- VP7
- VP4
- VQ
- VQ4
- VQZ
- VQD
- VZS
- VFS
- VS
- VS7

L plug connector (L): VQZ312⁰₁(R)-□L□-C6, C8, C10, 02

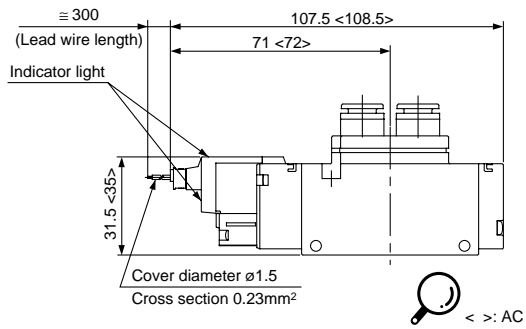

DIN connector (Y): VQZ312⁰₁(R)-□Y□-C6, C8, C10, 02

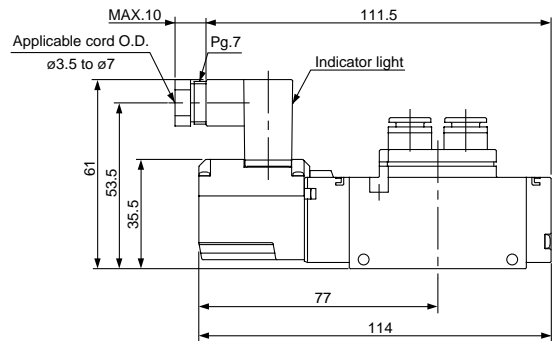

M plug connector (M): VQZ312⁰₁(R)-□M□-C6, C8, C10, 02

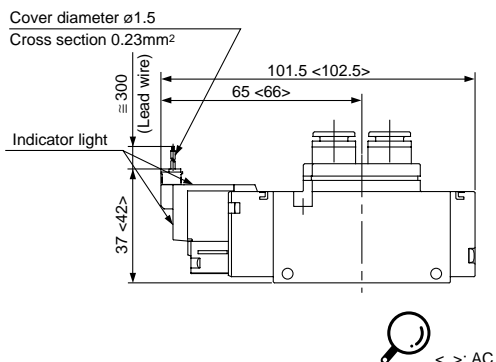

VQZ1000/2000/3000 Body Ported

Dimensions: VQZ3000

2 position double

Grommet (G): VQZ322₁(R)-□G□-C6, C8, C10, 02

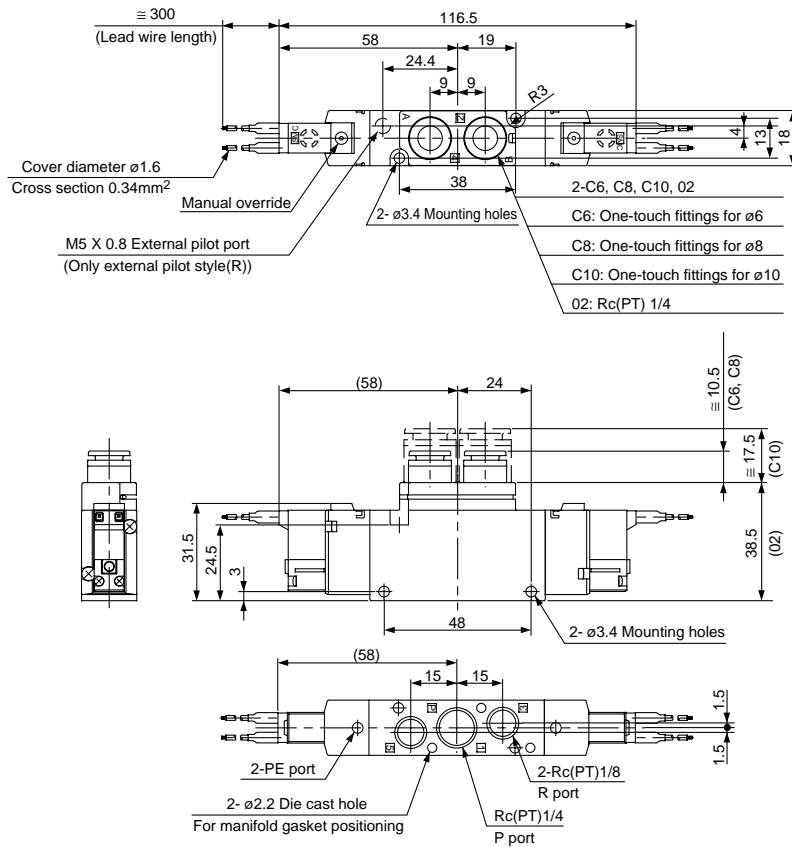

L plug connector (L): VQZ322₁(R)-□L□-C6,C8,C10,02

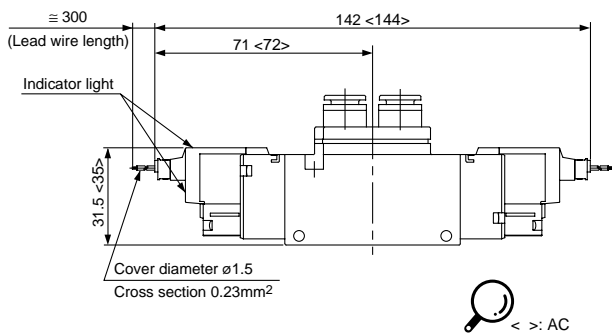

DIN connector (Y): VQZ322₁(R)-□Y□-C6, C8, C10, 02

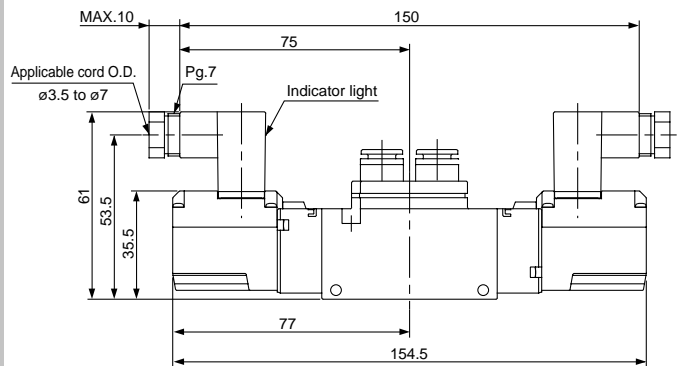

M plug connector (M): VQZ322₁(R)-□M□-C6, C8, C10, 02

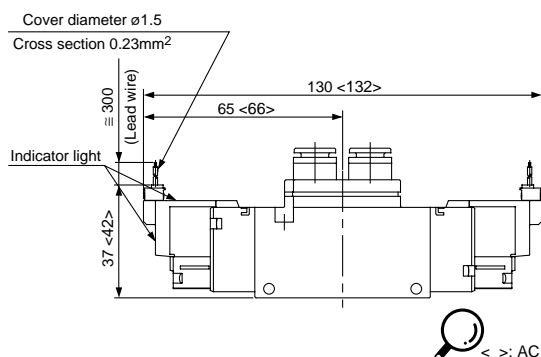

VQZ3000

3 position closed center/exhaust center/pressure center

Grommet (G): VQZ3³₄2⁰₁(R)-□G□-C6, C8, C10, 02

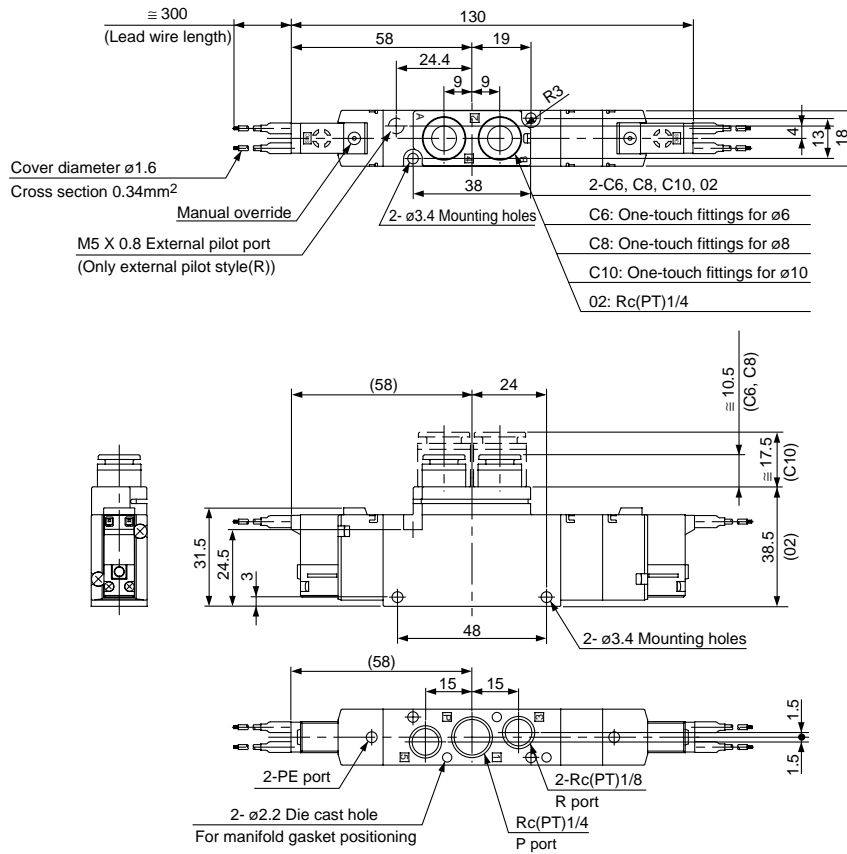

- SY
- SYJ
- SX
- VK
- VZ
- VF
- VFR
- VP7
- VP4

- VQ
- VQ4
- VQZ
- VQD
- VZS
- VFS
- VS
- VS7

L plug connector (L): VQZ3³₄2⁰₁(R)-□L□-C6, C8, C10, 02

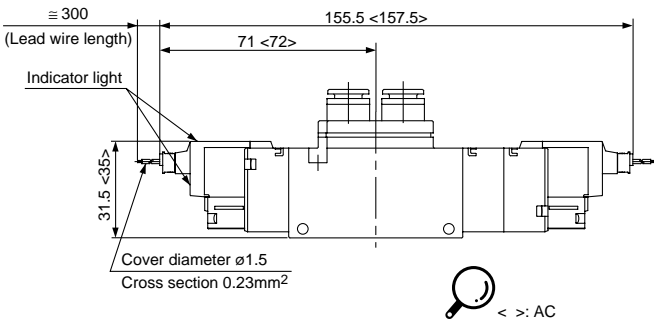

DIN connector (Y): VQZ3³₄2⁰₁(R)-□Y□-C6, C8, C10, 02

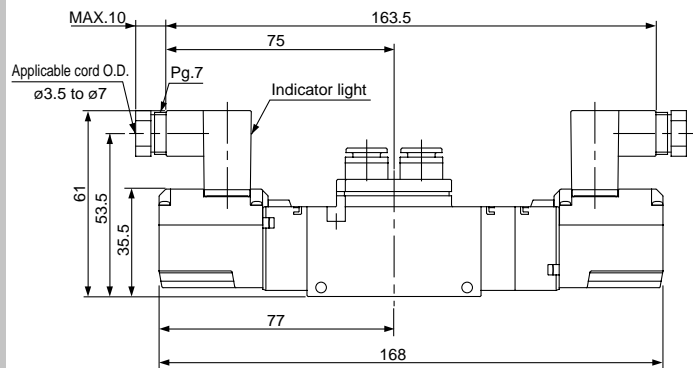

M plug connector (M): VQZ3³₄2⁰₁(R)-□M□-C6, C8, C10, 02

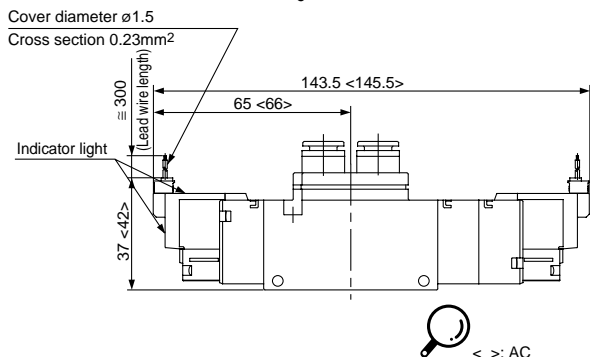

Body Ported

Plug Lead Unit

5 Port Solenoid Valve

VQZ1000/2000/3000

Manifold Connector Kit

How to Order Manifold

VV5QZ 1 2 — 08 **C** —

Series

1	VQZ1000
2	VQZ2000
3	VQZ3000

Manifold

2	Body ported
---	-------------

Stations

02	2 stations
⋮	⋮
20	20 stations

Kit

C	Connector
---	-----------

DIN rail mounting

—	None
D	DIN rail mounting (DIN rail standard length)
DO ⁽¹⁾	DIN rail mounting (Without DIN rail)

Note 1) Order DIN rail separately. Refer to p.1.12-23 for DIN rail model number.

How to Order Valve

VQZ 1 1 2 1 — 5 **M** — C6

Series

1	VQZ1000 Body width 10mm
2	VQZ2000 Body width 15mm
3	VQZ3000 Body width 18mm

Configuration

1	2 position single
2	2 position double
3	3 position closed center
4	3 position exhaust center
5*	3 position pressure center
8	3 port for mixture mounting N.C.
9	3 port for mixture mounting N.O.

* Except for VQZ1000 and metal seal style

Body

2	Body ported
---	-------------

Seal

0	Metal seal
1	Rubber seal

Function

Symbol	Specification	DC	AC
—	Standard	(1.0W) ○	○ ⁽³⁾
K ⁽¹⁾	High pressure (Metal seal)	(1.0W) ○	—
Y	Low wattage	(0.5W) ○	—
R ⁽²⁾	External pilot	○	○

Note 1) Option
Note 2) Refer to p.1.12-27 for details about external pilot specification.
Note 3) Refer to p.1.12-7 for power consumption for AC style.
Note 4) When specifying more than one option, indicate them alphabetically.

Port size {4(A), 2(B) port}

Symbol	Port size	VQZ1000	VQZ2000	VQZ3000
C3	One-touch fitting for ø3.2	○	—	—
C4	One-touch fitting for ø4	○	○	—
C6	One-touch fitting for ø6	○	○	○
C8	One-touch fitting for ø8	—	—	○
C10	One-touch fitting for ø10	—	—	○
M5	M5 thread	○	○	—
02	Rc(PT)1/4	—	—	○

Note 1) Refer to p.1.12-27 for inch-sizes and one-touch fittings.

Manual override

—	Non-locking push style (Flush)
B	Locking style (Slotted)

Electrical entry

Symbol	Electrical entry	Light and surge suppressor
G	Grommet (DC specification)	Without
L	L plug connector with lead wire	With
LO	L plug terminal without connector	
M	M plug connector with lead wire	
MO	M plug terminal without connector	
Y ⁽¹⁾	DIN connector	Without
YO ⁽¹⁾	DIN terminal without connector	
YZ ⁽¹⁾	DIN connector	With
YOS ⁽¹⁾	DIN terminal without connector	With (w/o light)

Note 1) DIN style is applicable to VQ2000, 3000.
Note 2) Standard lead wire length: 300mm.

Coil voltage

1*	100V AC (50/60Hz)
2*	200V AC (50/60Hz)
3*	110V AC (50/60Hz)
4*	220V AC (50/60Hz)
5	24V DC
6	12V DC
9*	Others

* Consult SMC when requiring grommet style, AC specification and others.

Manifold Specifications

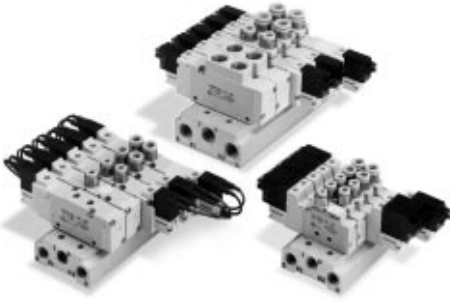

Series	Base model	Piping specification		Applicable valve	Applicable stations	Manifold base weight (g)
		Piping	Port size			
			1(P), 3/5(R) 4(A), 2(B)			
VQZ1000	VV5QZ12-□□□	Top	Rc(PT) 1/8	C3(ø3.2) C4(ø4) C6(ø6) M5(M5 thread)	VQZ1□20 VQZ1□21	2 to 20 stations 2 stations: 64 addition per 1 station: 18
VQZ2000	VV5QZ22-□□□	Top	Rc(PT) 1/8	C4(ø4) C6(ø6) M5(M5 thread)	VQZ2□20 VQZ2□21	2 to 20 stations 2 stations: 86 addition per 1 station: 26
VQZ3000	VV5QZ32-□□□	Top	Rc(PT) 1/4	C6(ø6) C8(ø8) C10(ø10) Rc(PT)1/4	VQZ3□20 VQZ3□21	2 to 20 stations 2 stations: 181 addition per 1 station: 53

SY

SYJ

SX

VK

VZ

VF

VFR

VP7

VP4

How to Order Manifold Assembly (Example)

VV5QZ22-05C 1 set (C kit 5 stations manifold base)

- * **VVQZ2000-10A-2** 1 set (Blank plate assembly)
- * **VQZ2120-5M-C6** 1 set (Valve P/N-single solenoid)
- * **VQZ2220-5M-C6** 2 set (Valve P/N-double solenoid)
- * **VQZ2320-5M-C6** 1 set (Valve P/N-3 position)

→ Prefix "*" mark to valves etc. to be assembled on the manifold.

→ Write sequentially from the 1st station on the D side

Add valve suffix and option number to the manifold base number.
When part numbers written collectively are complicated, specify by using a manifold specification form.

C6: One-touch fitting for ø6

VQ

VQ4

VQZ

VQD

VZS

VFS

VS

VS7

VQZ1000/2000/3000 Body Ported

Dimensions: VQZ1000

VV5QZ12-Station C

Grommet (G)

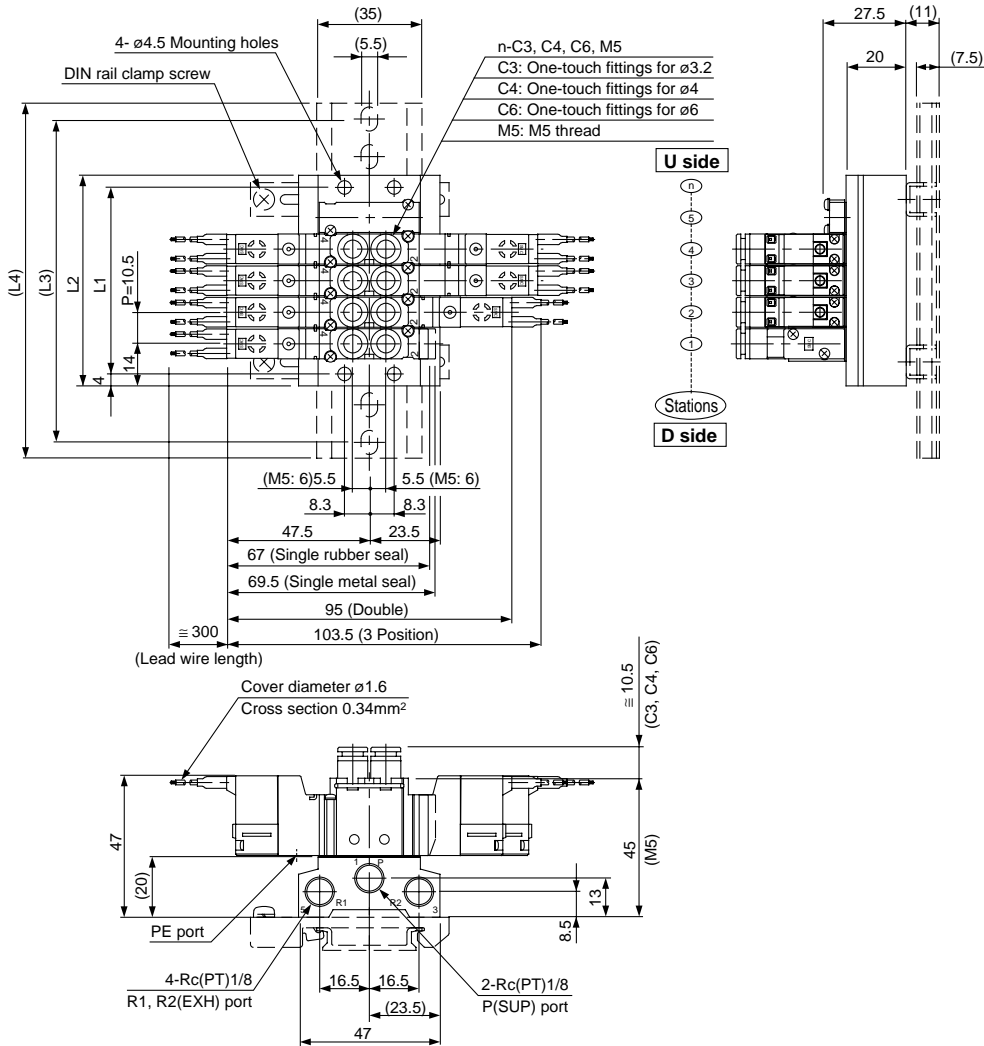

L plug connector (L)

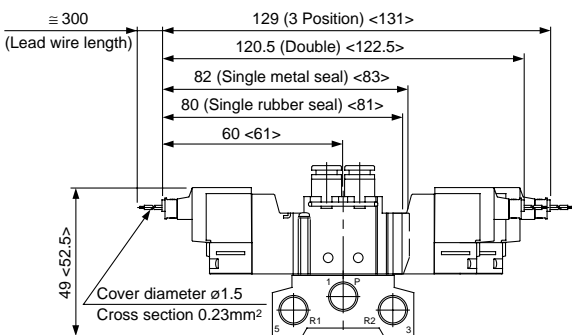

M plug connector (M)

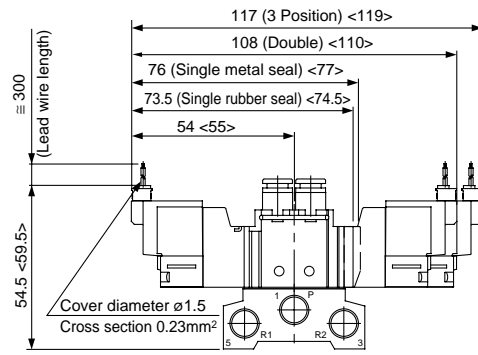

Dimensions Equation $L1=10.5n+9.5$ $L2=10.5n+17.5$

n: Station (Max. 20 stations)

L \ n	2	3	4	5	6	7	8	9	10	11	12	13	14	15	16	17	18	19	20
L1	30.5	41	51.5	62	72.5	83	93.5	104	114.5	125	135.5	146	156.5	167	177.5	188	198.5	209	219.5
L2	38.5	49	59.5	70	80.5	91	101.5	112	122.5	133	143.5	154	164.5	175	185.5	196	206.5	217	227.5
L3	62.5	75	87.5	100	100	112.5	125	137.5	150	162.5	175	175	187.5	200	212.5	225	237.5	237.5	250
L4	73	85.5	98	110.5	110.5	123	135.5	148	160.5	173	185.5	185.5	198	210.5	223	235.5	248	248	260.5

VQZ2000

VV5QZ22-Station C

Grommet (G)

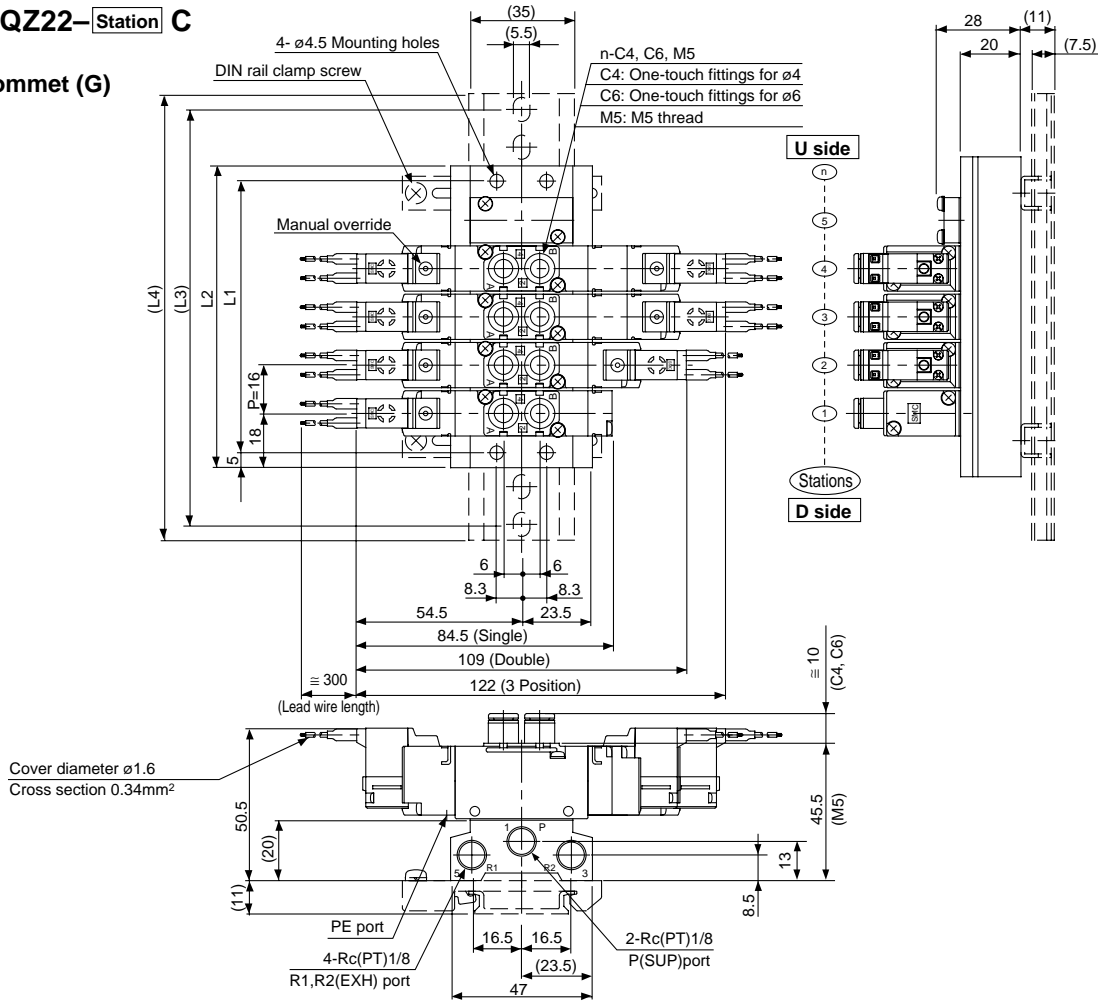

L plug connector (L)

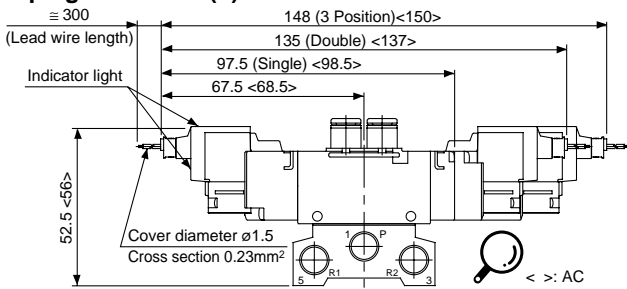

DIN connector (Y)

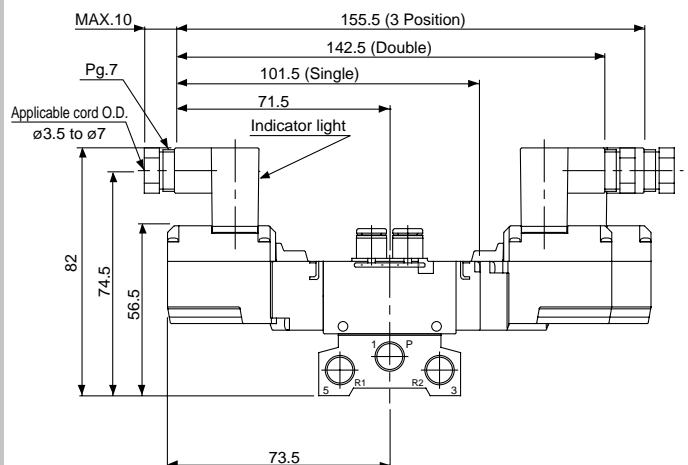

M plug connector (M)

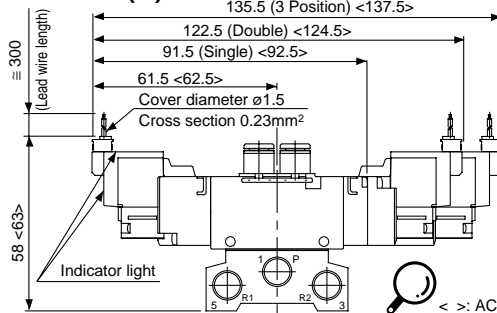

Dimensions

Equation $L1=16n+10$ $L2=16n+20$

n: Station (Max. 20 stations)

L \ n	2	3	4	5	6	7	8	9	10	11	12	13	14	15	16	17	18	19	20
L1	42	58	74	90	106	122	138	154	170	186	202	218	234	250	266	282	298	314	330
L2	52	68	84	100	116	132	148	164	180	196	212	228	244	260	276	292	308	324	340
L3	75	87.5	112.5	125	137.5	162.5	175	187.5	200	225	237.5	250	275	287.5	300	312.5	337.5	350	362.5
L4	85.5	98	123	135.5	148	173	185.5	198	210.5	235.5	248	260.5	285.5	298	310.5	323	348	360.5	373

- SY
- SYJ
- SX
- VK
- VZ
- VF
- VFR
- VP7
- VP4

- VQ
- VQ4
- VQZ
- VQD
- VZS
- VFS
- VS
- VS7

Manifold Option

Blank plate assembly

VVQZ1000-10A-2
VVQZ2000-10A-2
VVQZ3000-10A-2

This is used when removing the valve for maintenance, or reserving a valve mounting space on the manifold for future use.

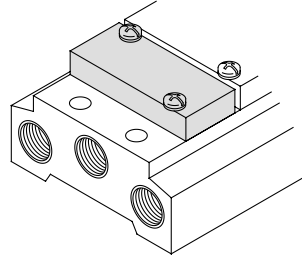

DIN rail

AXT100-DR-□

* Suffix number into □ from the dimension table below. Refer to each manifold dimensions for L dimension.

To order a manifold with DIN rail already attached, insert "D" at the end of the manifold part number. The DIN rail is approximately 30mm longer than the length of manifold.

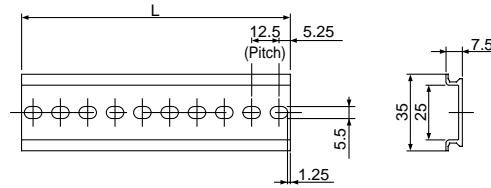

L dimension

No.	1	2	3	4	5	6	7	8	9	10	11	12	13	14	15	16	17	18	19	20
L	23	35.5	48	60.5	73	85.5	98	110.5	123	135.5	148	160.5	173	185.5	198	210.5	223	235.5	248	260.5

$L = 12.5n + 10.5$

No.	21	22	23	24	25	26	27	28	29	30	31	32	33	34	35	36	37	38	39	40
L	273	285.5	298	310.5	323	335.5	348	360.5	373	385.5	398	410.5	423	435.5	448	460.5	473	485.5	498	510.5

Fitting blank plug

KQP-23-X19
KQP-04-X19
KQP-06-X19
KQP-08-X19
KQP-10-X19

● Color: White

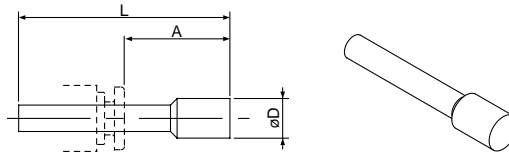

Dimensions

Applicable fitting ød	Part No.	A	L	D
3.2	KQP-23-X19	16	31.5	3.2
4	KQP-04-X19	16	32	6
6	KQP-06-X19	18	35	8
8	KQP-08-X19	20.5	39	10
10	KQP-10-X19	22	43	12

EXH port silencer

Silencer is installed in the EXH port.

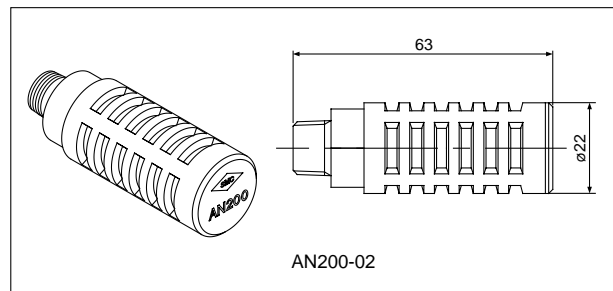
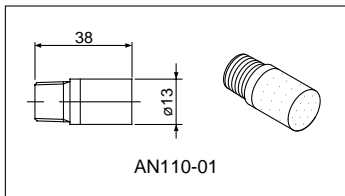

Dimensions

Model	Silencer P/N
VQZ1000	AN110-01
VQZ2000	AN110-01
VQZ3000	AN200-02

Port plug

VVQZ100-CP(For VQZ1000/VQZ2000)
VVQZ2000-CP(For VQZ3000)

Used to block an unused cylinder port when using a 4 way valve as a 3 way valve.

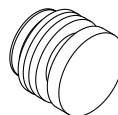

SY

SYJ

SX

VK

VZ

VF

VFR

VP7

VP4

VQ

VQ4

VQZ

VQD

VZS

VFS

VS

VS7

VQZ1000/2000/3000 Body Ported

Manifold Option

Double check block (Externally placed downstream): For VQZ1000 only
VQ1000-FPG-□□

Using a 3 position exhaust center valve, this check block can stop and hold a cylinder in mid-stroke. The combination of a 2 position single or double solenoid with a double check will prevent the cylinder from "dropping" at stroke end when the residual supply pressure is released.

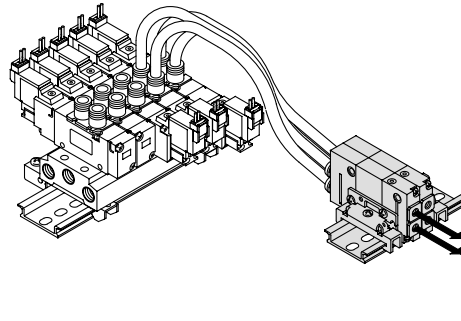

Check Valve Operational Principles

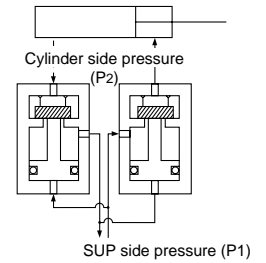

Specifications

Max. operating pressure	0.8MPa
Min. operating pressure	0.15MPa
Ambient and fluid temp.	-5 to 50°C
Effective area (Cv) ⁽¹⁾	2.7mm ² (0.15)
Max. operating frequency	180 c.p.m

Note 1) As per JISB8375-1981
 (Supply pressure: 0.5MPa)

Dimensions

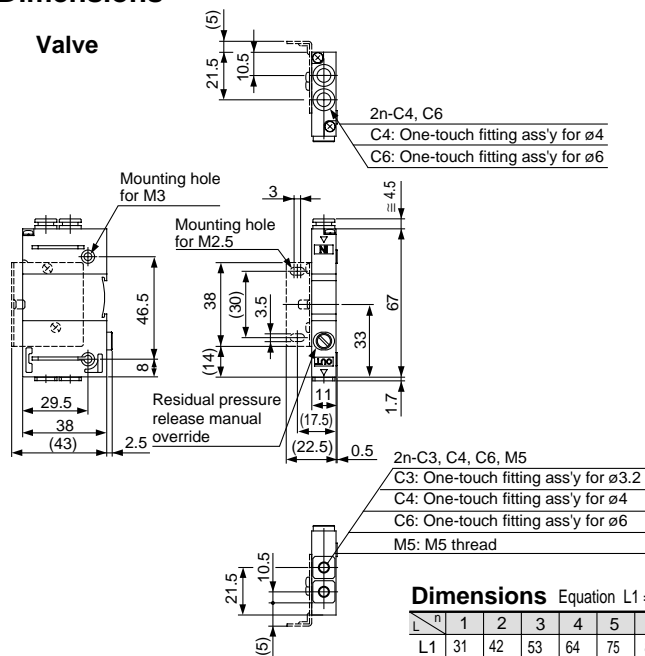

Manifold

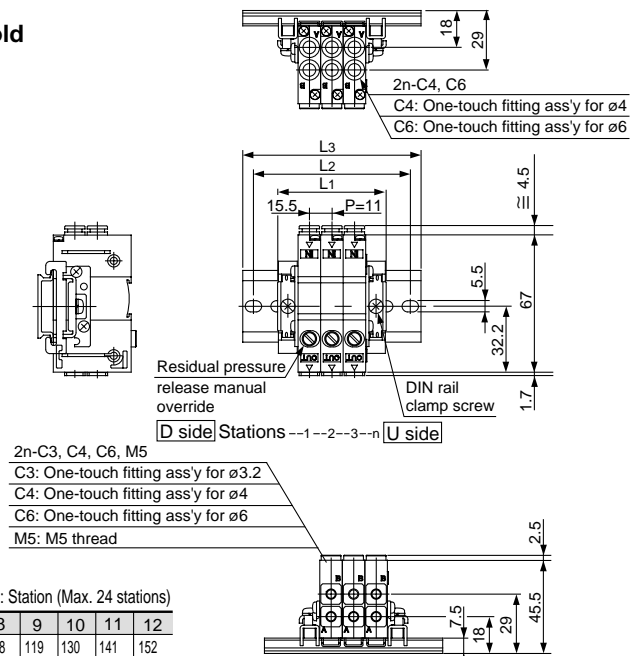

Dimensions Equation $L1 = 11n + 20$ n: Station (Max. 24 stations)

L ⁿ	1	2	3	4	5	6	7	8	9	10	11	12
L1	31	42	53	64	75	86	97	108	119	130	141	152
L2	50	62.5	75	87.5	100	112.5	125	137.5	150	162.5	175	
L3	60.5	73	85.5	98	110.5	123	135.5	148	160.5	173	185.5	

L ⁿ	13	14	15	16	17	18	19	20	21	22	23	24
L1	163	174	185	196	207	218	229	240	251	262	273	284
L2	187.5	187.5	200	212.5	225	237.5	250	250	262.5	275	287.5	300
L3	198	198	210.5	223	235.5	248	260.5	260.5	273	285.5	298	310.5

How to Order

Double check block

VQ1000-FPG-**C4 M5 F**

IN side port side		OUT side port side	
C4	One-touch fitting for ø4	M5	M5 thread
C6	One-touch fitting for ø6	C3	One-touch fitting for ø3.2
		C4	One-touch fitting for ø4
		C6	One-touch fitting for ø6

Option	
-	None
D	DIN rail mounting (for manifold)
F	With bracket
N	With name plate

Manifold

VVQ1000-FPG-**06**

Stations	
01	1 station
⋮	⋮
16	16 stations

<Example>

VVQ1000-FPG-06...6 stations of manifold
 * VQ1000-FPG-C4M5-D, 3 sets } Double check block
 * VQ1000-FPG-C6M5-D, 3 sets }

<Examples>

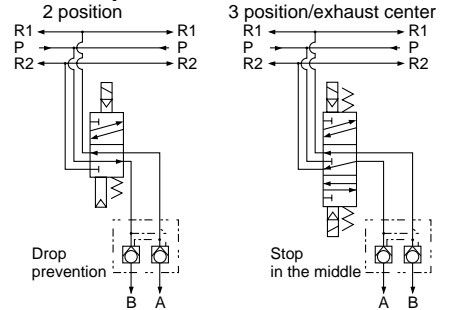

⚠ Cautions

- Since air leakage from the pipe between the valve and cylinder or the fittings will prevent the cylinder from stopping for a long time. Check for air leakage using neutral household detergent, such as dish washing soap. Also check the cylinder's tube gasket, piston seal and rod seal for leakage.
- Since slight air leakage from One-touch fittings is allowed, use of a piping screw (with M5 thread) is recommended when stopping the cylinder in the middle for a long time.
- Combining double check block with 3 position closed center or pressure center solenoid valve will not work.
- A M5 fitting assembly is attached, without being incorporated in the perfect block. After screwing in the fittings, mount the ass'y on the double check block. Tightening torque: 0.8 to 1.2Nm
- If exhaust side of double check block is narrowed down too much, this decreases the intermediate stop accuracy.

Manifold Option

Double check block (Externally placed downstream): For VQ2000 only VQ2000-FPG-□□-□

Using a 3 position exhaust center valve, this check block can stop and hold a cylinder in mid-stroke. The combination of a 2 position single or double solenoid with a double check block will prevent the cylinder from "dropping" at stroke end when residual supply pressure is released.

Specifications

Max. operating Pressure	0.8MPa
Min. operating Pressure	0.15MPa
Ambient and fluid temp.	-5 to 50°C
Effective area (Cv) ⁽¹⁾	18mm ² (1.0)
Max. operating frequency	180 c.p.m

Note 1) As per JISB8375-1981
(Supply pressure: 0.5MPa)

Check Valve Operational Principles

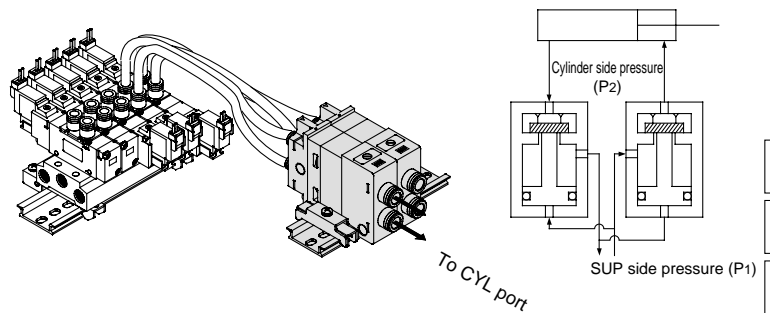

Dimensions

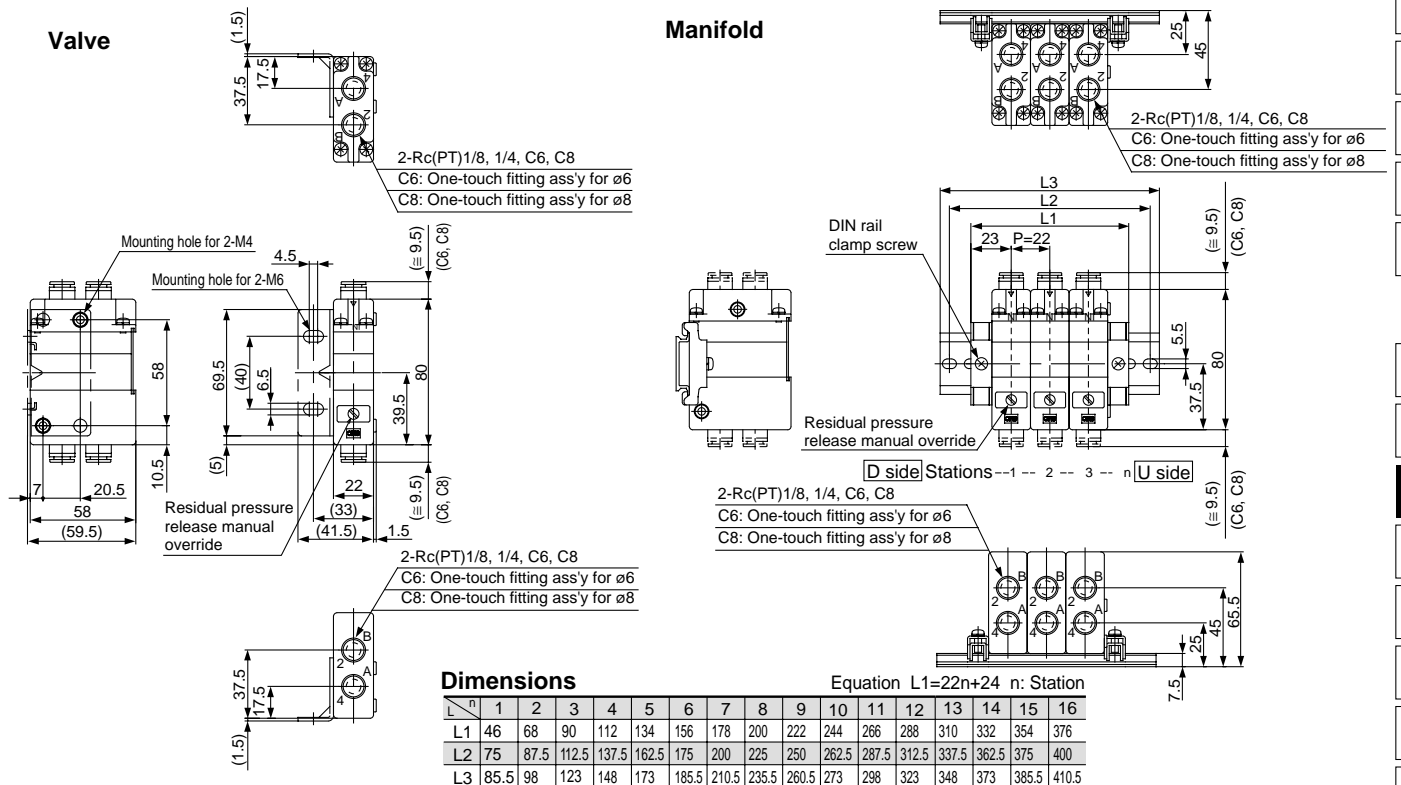

How to Order

Double check block

VQ2000-FPG-01 01 F

IN side port size

01	Rc(PT)1/8
02	Rc(PT)1/4
C6	One-touch fitting for ø6
C8	One-touch fitting for ø8

OUT side port size

01	Rc(PT)1/8
02	Rc(PT)1/4
C6	One-touch fitting for ø6
C8	One-touch fitting for ø8

Option

-	None
D	DIN rail mounted (for manifold)
F	With bracket
N	With name plate

Manifold

VVQ2000-FPG-06

Stations

01	1 station
...	...
16	16 stations

<Example>

VVQ2000-FPG-06...6 stations of manifold

* VQ2000-FPG-C6C6-D, 3 sets } Double check block
 * VQ2000-FPG-C8C8-D, 3 sets }

Caution

- Since air leakage from the pipe between the valve and cylinder or the fittings will prevent the cylinder from stopping for a long time. Check for air leakage using neutral household detergent, such as dish washing soap. Also check the cylinder's tube gasket, piston seal and rod seal for leakage.
- Since slight air leakage from One-touch fittings is allowed, use of a piping screw (with M5 thread) is recommended when stopping the cylinder in the middle for a long time.
- Combining double check block with 3 position closed center or pressure center solenoid valve will not work.
- When screwing the fittings in the double check block, applied torque is as shown below:

Thread	Torque Nm
Rc(PT)1/8	7 to 9
Rc(PT)1/4	12 to 14

- Set the cylinder load so that the cylinder pressure will be within two times that of the supply pressure.
- If exhaust side of double check block is narrowed down too much, this decreases the intermediate stop accuracy.

Examples

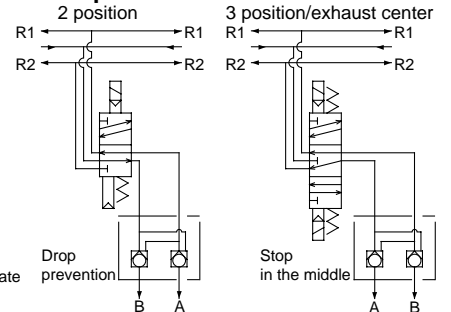

VQZ1000/2000/3000 Body Ported

One Side Solenoid (Latching Solenoid)

The standard 2 position double solenoid valve has two solenoids, one on each end of the valve body. The latching solenoid option (with self holding mechanism) functions in the same manner as a 2 position double solenoid but uses only one solenoid to do the job.

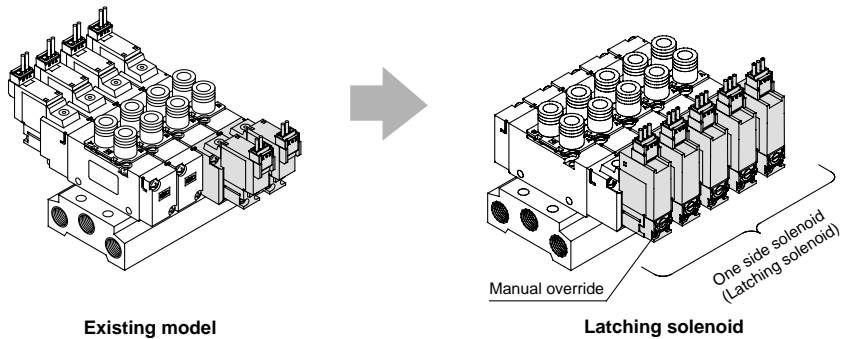

How to Order Latching Solenoid Valve

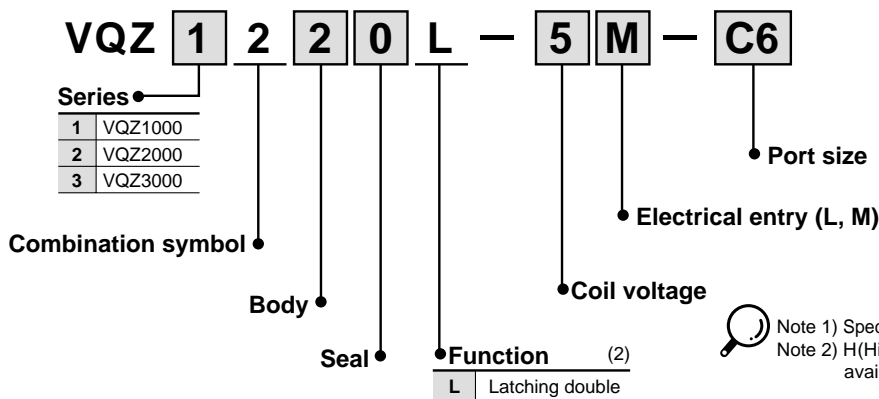

Note 1) Specifications are same as standard except for the function.
 Note 2) H(High pressure style) and Y(Low wattage style) are not available.

Wiring

Lead wires are connected to the valve as shown below. Connect them with the power supply.

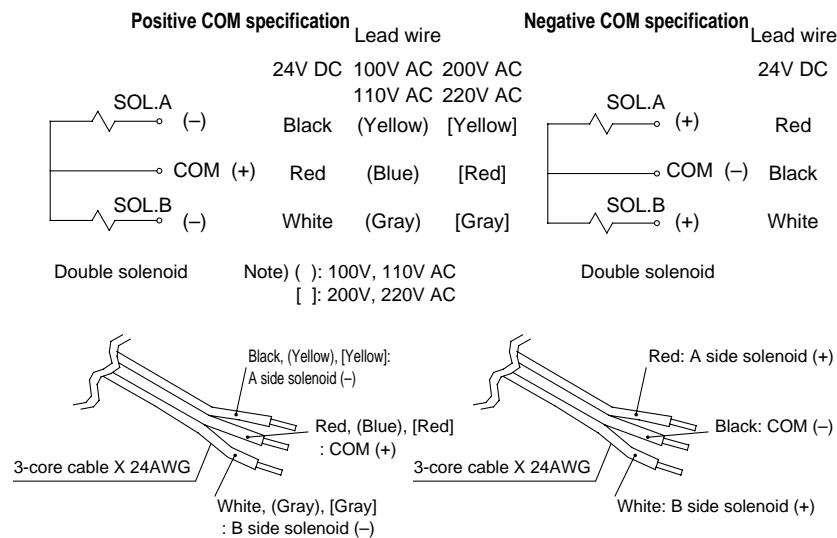

Electrical Circuit

Latching solenoid (DC)

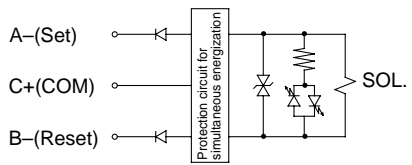

Latching solenoid (AC)

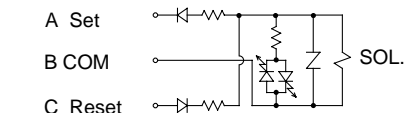

Note 1) -Set side in energized state: Lighting (Orange)
 -Reset side in energized state: Lighting (Green)
 -With miss-wiring preventing function (Stop diode)
 -With surge absorption function (ZNR/Surge absorption diode)
 Note 2) Flow direction: P→A (A (set) side in energized state)
 Flow direction: P→R (B (reset) side in energized state)
 Note 3) Negative COM specification available.

⚠ Caution

Cautions for Latching Use

1. Use a circuit in which the ON and OFF signals are not simultaneously energized.
2. Minimum energization time for self holding is 20ms.
3. Avoid using the latching solenoid valves in environments where impact or collisions with the valve might occur. Also, do not use in places where a strong magnetic fields are present.
4. The armature in the solenoid is set in the B side ON position (Reset) at the factory. However shifting of the armature might occur during shipping so please confirm the position by energizing the solenoid.
5. Please consult SMC for extended energization applications.

Manual Override

The manual override is on the pilot valve for latching solenoid valves.

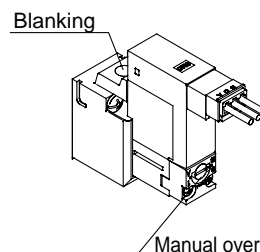

-To lock in set position (Flow path: P→A): Turn the manual override clockwise by 180° to make A press down. Valve is now locked in the set condition. (Flow path: P→A)
 -To reset (Flow path: P→B): Turn manual override counterclockwise to mark B and press down. Valve will then be in the reset condition. (Flow path: P→B).

Series VQZ Body Ported

Options

External Pilot

The external pilot specification is used when the operating pressure is below the minimum operating pressure 0.1 to 0.2 MPa or when valve is used for a vacuum application. For the external pilot valve, an "R" should be attached to the valve and the manifold part number. (See the below.)

Example/Valve

VQZ2120R—5M—C6

External pilot specification

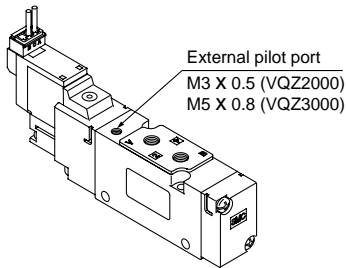

Pressure Specifications

Series		VQZ2000, 3000		
		2 position single	2 position double	3 position
External pilot pressure range *	Metal seal	0.1 to 0.7MPa only VQZ3000, 3 position 0.15 to 0.7MPa		
	Rubber seal	0.15 to 0.7MPa	0.1 to 0.7MPa	0.2 to 0.7MPa
Operating pressure range *		Vacuum to 0.7MPa		

* In case of high pressure style, upper limit of max. operating pressure and external pilot pressure range is 1MPa.

Inch Size One-touch Fittings and Option Thread

Manifolds are available with inch-size One-touch fitting for the cylinder ports. Sub-plates and manifolds with NPT, NPTF or PF threads are available.

How to Order Valve

VQZ2120—5M—N7 T

Thread (Cylinder ports and P, R ports)

—	Rc(PT)
N	NPT
T	NPTF
F	G(PF)

Note) R port of VQZ2000 is only G(PF) 1/16

Cylinder ports

Symbol	N1	N3	N7	N9	N11	M5	O2
Applicable tube O.D. (Inch)	ø 1/8"	ø 5/32"	ø 1/4"	ø 5/16"	ø 3/8"	M5	1/4
A, B port	VQZ1000	●	●	—	—	●	—
	VQZ2000	—	●	●	—	●	—
	VQZ3000	—	—	●	●	—	●

Note) Millimeter sizes of One-touch fittings (□) are also available.

How to Order Manifold

VV5QZ22—05C—00T

Thread (P, R ports)

—	Rc(PT)
00N	NPT
00T	NPTF
00F	G(PF)

Dust Tight/Jet Proof (IP65)

Optional IP65 model is available on valves with DIN connector electrical entry.

How to Order Valve

(Applicable to VQZ2000/3000 rubber seal)

VQZ3121—5YZB W—02

IP65 rated

—	No (Standard)
W ⁽¹⁾	IP65 rated

Note 1) The pilot exhaust of the IP65 valves is common with main valve exhaust. (The standard valve has an individual exhaust for the pilot valve.)

SY

SYJ

SX

VK

VZ

VF

VFR

VP7

VP4

VQ

VQ4

VQZ

VQD

VZS

VFS

VS

VS7

Replacement Parts

One-touch Fitting Assembly (For cylinder port)

Fitting size	C3	C4	C6	C8	C10
Series					
VQZ1000, 2000	VVQ1000-50A-C3	VVQ1000-50A-C4	VVQ1000-50A-C6	—	—
VQZ3000	—	—	VVQ1000-51A-C6	VVQ1000-51A-C8	VVQ1000-51A-C10

Note) Order is accepted in 10 units.

<Plug connector assembly>

DC (+COM)

· Single

AXT661-14A-□

· Latching

AXT661-13A-□

DC (-COM)

· Latching

AXT661-13AN-□

100V, 110V AC

· Single

AXT661-31A-□

· Latching

AXT661-32A-□

200V, 220V AC

· Single

AXT661-34A-□

· Latching

AXT661-35A-□

Only connector and sockets (3 pcs)

AXT661-12A

Lead wire length

—	300mm
6	600mm
10	1000mm
20	2000mm
30	3000mm

Standard wire length of valve with plug connector is 300mm.

When requiring valve with 600mm length lead wire specify the model number of valve without plug connector and plug connector assembly.

<Gasket and screw assembly>

	Part No.
VQZ1000	VQZ1000-GS-2
VQZ2000	VQZ2000-GS-2
VQZ3000	VQZ3000-GS-2



Note) Above part number consists of 10 units. Each unit has one gasket and two screws. Orders are accepted in 10 units.

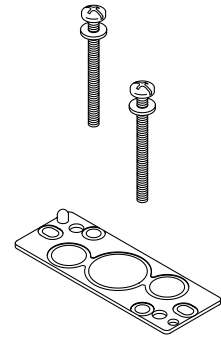

<Pilot valve assembly>

VQ11 1 □ — 5 G — □

Series

1	VQZ1000, 2000, 3000
---	---------------------

Function

Symbol	Specification	DC	AC
—	Standard	(1.0W) ○	○
K ⁽¹⁾	High pressure (Metal seal only)	(1.0W) ○	—
Y	Low wattage	(0.5W) ○	—
L ⁽³⁾	Latching	(1.0W) ○	○



Note 1) Option

Note 2) When specifying more than one option, please indicate them alphabetically.

Note 3) K (High pressure) and Y (Low wattage) are not available.

Electrical entry: L / M plug connector only.

Applicable model

—	VQZ2000, 3000
4	A and B side of VQZ1000 single double solenoid type A side of VQZ1000 3 position
5	B side of VQZ1000 3 position

Electrical entry

Symbol	Electrical entry	Light and surge suppressor
G	Grommet (DC specification)	Without
L	L plug connector with lead wire	With
LO	L plug terminal without connector	
M	M plug connector with lead wire	
MO	M plug terminal without connector	Without
Y ⁽¹⁾	DIN connector	
YO ⁽¹⁾	DIN terminal without connector	
YZ ⁽¹⁾	DIN connector	With
YOS ⁽¹⁾	DIN terminal without connector	With (w/o light)



Note 1) DIN is applicable to VQZ2000, 3000.

Coil voltage

1 *	100V AC (50/60Hz)
2 *	200V AC (50/60Hz)
3 *	110V AC (50/60Hz)
4 *	220V AC (50/60Hz)
5	24V DC
6	12V DC
9 *	Others



* Consult SMC when requiring grommet type of AC specification or others.