

Two Hand Control Valve

VR51 Series



RoHS

An output is available through synchronized, two-handed operation (within 0.5 s)!



Conforming to EN574

(Interchangeable with XT92-67□)

Example of a basic circuit diagram

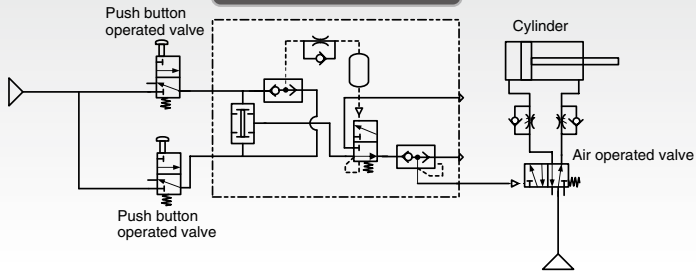

Equipment having a safety circuit

When starting an operation, accidents such as fingers being caught can be prevented, by requiring both hands to start these push button operated valves.

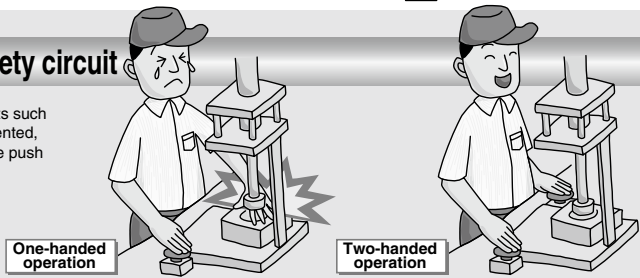

- VM
- VMG
- VR
- VR51
- VHK
- VH
- VHS□
- VHS

Application Examples

Press fitting with an air cylinder, Caulking

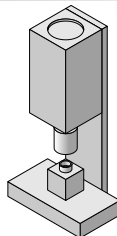

Clamping

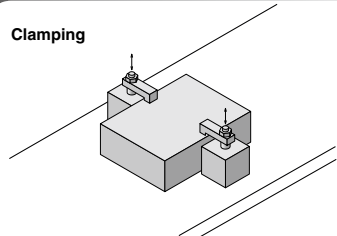

Two Hand Control Valve VR51 Series



How to Order

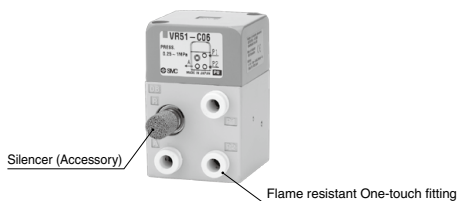

VR51 - C06 B

- Two hand control valve
- Option

| | |
|-----|--------------|
| Nil | None |
| B | With bracket |
- Connection piping size

| | |
|-----|--|
| C06 | Flame resistant One-touch fitting ø6 |
| C07 | Flame resistant One-touch fitting ø1/4 |

With bracket (Option)

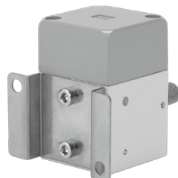

Back side mounting



Bottom mounting

Specifications

| | | | |
|-------------------------------|-------------|---|------|
| Fluid | | Air | |
| Operating pressure | | 0.25 to 1 MPa | |
| Proof pressure | | 1.5 MPa | |
| Ambient and fluid temperature | | -5 to 60°C (with no freezing) | |
| Flow rate characteristics | | C [dm ³ /(s·bar)] | Cv |
| P → A | | 0.3 | — |
| A → R | | 1.0 | 0.12 |
| Port size | Metric size | ø6 | |
| | Inch size | ø1/4 | |
| Applicable tubing material | | Nylon, Soft nylon, Polyurethane, Flame resistant (FR) soft nylon, FR double layer, FR double layer polyurethane | |
| Weight | | 340 g | |
| Accessory | Silencer | Part No.: AN101-01 | |
| Option | Bracket | Part No.: VR51B | |
| Standard | | EN574: 1996 + A1: 2008 Class: Type III A | |

Note) In the case of using soft nylon or polyurethane tubing, use caution when the maximum operating pressure of the tubing is used.

Example of a Basic Circuit Diagram

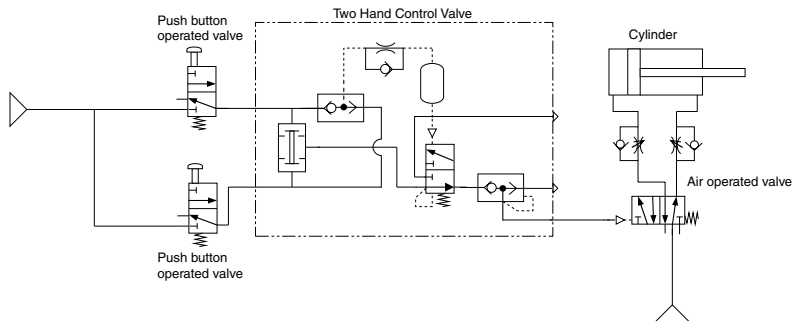

Construction

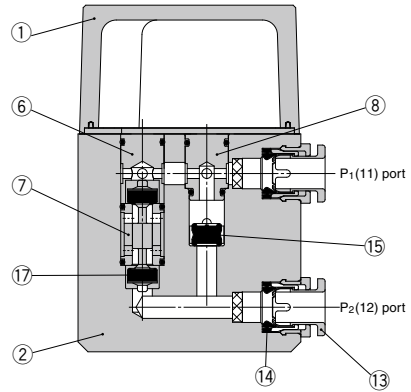
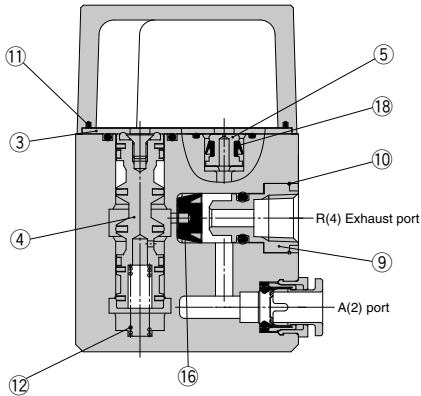

Component Parts

| No. | Description | Material | Note |
|-----|---------------|-------------------|---------------------------|
| 1 | Cover | Aluminum die-cast | Urban gray |
| 2 | Body | Aluminum die-cast | Urban white |
| 3 | Plate | Rolled steel | Nickel plated |
| 4 | Spool valve | Aluminum alloy | |
| 5 | Orifice | Brass | Electroless nickel plated |
| 6 | Valve seat | Aluminum alloy | |
| 7 | Valve guide B | Aluminum alloy | |
| 8 | Valve guide A | Aluminum alloy | |
| 9 | Guide | Brass | Electroless nickel plated |

| No. | Description | Material | Note |
|-----|-------------------|-----------------|------|
| 10 | Clip | Stainless steel | |
| 11 | Gasket | H-NBR | |
| 12 | Spring | Stainless steel | |
| 13 | Cassette assembly | | |
| 14 | Seal | NBR | |
| 15 | Valve | H-NBR | |
| 16 | Valve guide B | NBR | |
| 17 | Valve | H-NBR | |
| 18 | U-shaped seal | H-NBR | |

Timing of Motion

* The time lag for operation is different depending on the operating pressure. The higher the operating pressure, the shorter the time lag, and vice versa. When the operating pressure is 1 MPa, the time lag will be within approximately 0.1 seconds.

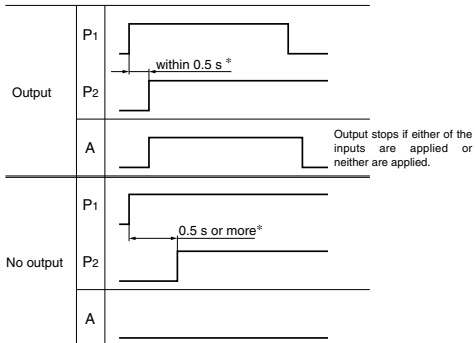

Circuit Diagram

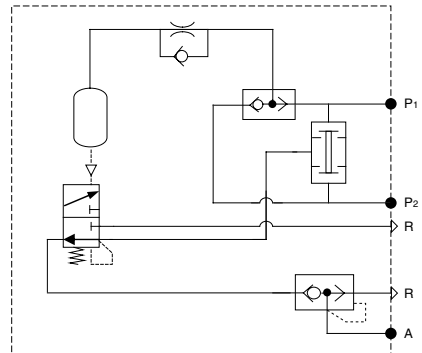

VM

VMG

VR

VR51

VHK

VH

VHS □

VHS

VR51 Series

Dimensions

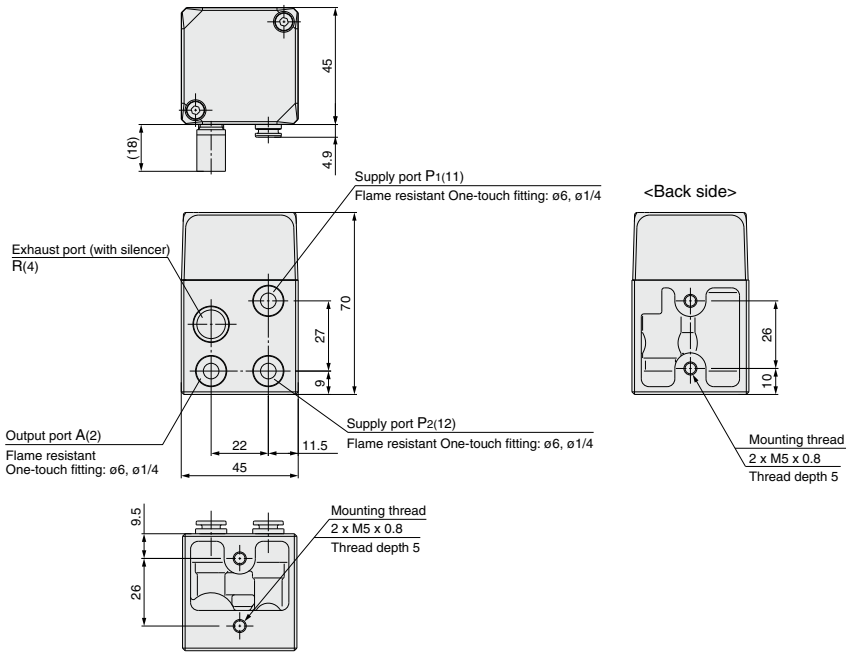

Bracket mounting dimensions

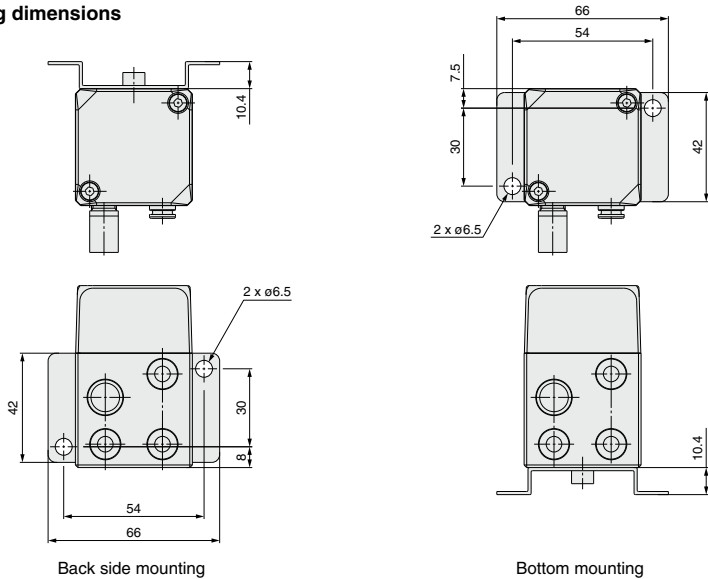



VR51 Series

Specific Product Precautions 1

Be sure to read this before handling the products.

Refer to back page 50 for Safety Instructions and pages 3 to 9 for 3/4/5 Port Solenoid Valve Precautions.

Design

Warning

1. Actuator drive

When an actuator, such as a cylinder, is to be driven using a valve, take appropriate measures to prevent potential danger caused by actuator operation.

2. Maintenance space

The installation should allow sufficient space for maintenance activities.

3. Ventilation

When a valve is used inside a sealed control panel, etc., provide ventilation to prevent a pressure increase caused by exhausted air inside the control panel or temperature rise caused by the heat generated by the valve.

4. Elimination of significant difference in piping length on VR51's inlet side

Make the piping work so that the piping lengths (L1 and L2) to the P1 and P2 sides to be connected to the inlet side of the VR51 have no significant difference. Additionally, make the piping work so that the piping lengths (L1' and L2') to two mechanical valves from the air supply also have no significant difference.

If the difference between the piping lengths is significant, a time lag occurs during pressure increase of P1 and P2. This may cause the output to malfunction even when operated at the same time.

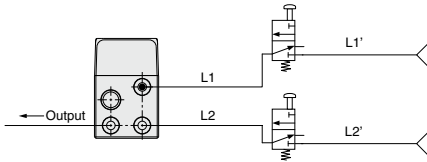

Selection

Warning

1. Confirm the specification.

The products presented in this catalog are designed only for use in compressed air systems. Do not operate at pressures or temperatures, etc., beyond the range of specifications, as this can cause damage or malfunction. (Refer to specifications.)

Contact SMC when using a fluid other than compressed air.

2. Using in low temperature

In the case of using in low temperature, take measures not to freeze the drainage or moisture.

Mounting

Warning

1. If air leakage increases or equipment does not operate properly, stop operation.

Check mounting conditions when air and power supplies are connected. Initial function and leakage tests should be performed after installation.

2. Operation manual

Mount and operate the product after reading the manual carefully and understanding its contents.

Also keep the manual where it can be referred to as necessary.

Mounting

Warning

3. Painting and coating

Warnings or specifications printed or pasted on the product should not be erased, removed or covered up.

Consult with SMC if paint is to be applied to resinous parts, as this may have an adverse effect due to the paint solvent.

Caution

1. Tubing, with the exception of coiled tubing, requires stationary installation. Do not use standard tubing (non-coiled) in applications where tubing is required to travel within a cable carrier. Tubing that travels may sustain abrasion, extension, or severance due to tensile force, or may result in removal of tubing from fitting. Use caution prior to use for proper application.

2. Transportation, installation, piping, operation, manipulation, maintenance, and inspection should be conducted by a knowledgeable and experienced person.

Otherwise, electric shock, injuries, fire, etc. may occur.

3. Do not modify the product because this will likely cause injuries and damage.

4. Do not wipe the product with a cloth containing chemicals.

Piping

Caution

1. Preparation before piping

Before piping is connected, it should be thoroughly blown out with air (flushing) or washed to remove chips, cutting oil and other debris from inside the pipe.

2. When piping on the product

In the case of connecting piping to the product, consult the operation manual and use caution to avoid making a mistake with the supply port, etc.

3. Connect tubing with some extra length to prevent torsion, stretching, or a moment load from being applied to the fittings and tubing. Damage to the fittings or flattening, as well as bursting or releasing of the tubing may occur, if the above is not followed.

4. The tubing connected to the product should be more than its minimum bending radius. If the minimum bending radius is tighter than that it should be, bending or flating of the tubing may occur.

The minimum bending radius is measured as following in accordance with JIS B 8381-1995.

JIS specifies the tubing deformation ratio measured at the minimum bending ratio to be 25% or less.

* Except for the TU, TIUB, TUH, TRBU, TAU and TUS series

Tube deformation ratio at the minimum bending radius is obtained through the following formula, based on tubing diameter and mandrel diameter by wrapping the same radius mandrel tube.

VM

VMG

VR

VR51

VHK

VH

VHS□

VHS



VR51 Series

Specific Product Precautions 2

Be sure to read this before handling the products.

Refer to back page 50 for Safety Instructions and pages 3 to 9 for 3/4/5 Port Solenoid Valve Precautions.

Piping

⚠ Caution

$$\eta = \left(1 - \frac{L-D}{2d}\right) \times 100$$

Here, η : Deformation ratio (%)
d: Tube diameter (mm)
L: Measured length (mm)
D: Mandrel diameter (mm)
(Twice against the minimum bending radius)

Test temperature: 20 ± 5°C
Relative humidity: 65 ± 5%

Tube deformation ratio at the minimum bending radius

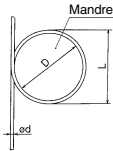

5. Do not use fluids other than specified. The only fluid that can be used is air.

Handling of One-touch Fittings

⚠ Caution

1. Tube insertion and removal from One-touch fittings

- 1) Attaching of tubing
 - a. Cut the tube perpendicularly, being careful not to damage the outside surface. Use SMC tube cutter "TK-1", "TK-2" or "TK-3". Do not cut the tube with pliers, nippers, scissors, etc., otherwise, the tube will be deformed and troubles may result.
 - b. Outside diameter of polyurethane tubing is swelled by applying internal pressure. As such, it may be that the tubing cannot be re-inserted into One-touch fittings. Make sure to confirm the tubing outside diameter, and when the accuracy of the outside diameter is more than + 0.15, insert into One-touch fitting again, not cutting the tubing to use it. When tubing is re-inserted into One-touch fitting, make sure to confirm that the tubing was able to go through the release bush smoothly.
 - c. Grasp the tube, slowly push it into the One-touch fittings until it comes to a stop.
 - d. Pull the tubing back gently to make sure it has a positive seal. Insufficient installation may cause air to leak or the tube to release.
- 2) Removal of tubing
 - a. Sufficiently depress the release bushing and tubing, making sure to apply even pressure around the release bushing.
 - b. Pull out the tubing while depressing the release bushing so that it does not pop out. If the release bushing is not depressed sufficiently, there will be an increased bite on the tubing and it will become more difficult to pull out.
 - c. When the removed tubing is reused, first cut off the section of the tubing which has been clamped.
Reusing the clamped portion of the tubing can cause problems such as leakage, difficulties in removal, etc.
- 3) Connecting fittings with metal rods
After connecting a fitting with a metal rod (KC series, etc.) to a One-touch fitting, do not use in combination with tubes, resin plugs, or reducers. Doing so may result in the fittings coming loose.
- 4) When mounting tubes, resin plugs, metal rods etc., do not press the release button.
Also, do not press the release button unnecessarily before mounting them. This may cause those parts to come off.

Precautions on Other Tubing Brands

⚠ Caution

1. When using tubing brands other than SMC, confirm that the tubing outside diameter tolerances satisfy the following specifications.

- | | |
|------------------------|-----------------------------------|
| 1) Nylon tubing | within ±0.1 mm |
| 2) Soft nylon tubing | within ±0.1 mm |
| 3) Polyurethane tubing | within ±0.15 mm within -0.2 mm |

Do not use tubing if the outside diameter tolerance is not satisfied. It may not be possible to connect the tubing, or leakage or disconnection may occur after connection.

Lubrication

⚠ Caution

1. Lubrication

- 1) The valve has been lubricated for life at the manufacturer, and does not require any further lubrication.
- 2) If a lubrication is applied in the system, use turbine oil Class 1 (no additive), ISO VG32.
However, once lubrication is applied it must be continued, as loss of the original lubricant may lead to malfunction.

Air Supply

⚠ Warning

1. Use clean air.

Do not use compressed air which contains chemicals, synthetic oils containing organic solvents, salts or corrosive gases, etc., as this can cause damage or malfunction.

⚠ Caution

1. Install air filters.

Install air filters close to valves at their upstream side. A filtration degree of 5 μm or less should be selected.

2. Install an air dryer, after cooler or Drain Catch, etc.

Air that includes excessive drainage may cause malfunction of valves and other pneumatic equipment. To prevent this, install an air dryer, after-cooler or water separator, etc.

3. If excessive carbon powder is seen, install a mist separator on the upstream side of the valve.

If excessive carbon dust is generated by the compressor, it may adhere to the inside of valves and cause malfunction.

Refer to SMC's "Air Cleaning Equipment" catalog for compressed air quality.

Pneumatic Pressure

⚠ Warning

1. Do not use the product with a pressure of under 0.25 MPa. The time lag for operating the VR51 is different depending on the operating pressure. The higher the operating pressure, the shorter the time lag, and vice versa. If used under 0.25 MPa, an output will be available; however, safety is not likely to be maintained, even though the time lag may exceed 0.5 seconds.
2. Supply the same pressure to P1 and P2.

If the difference in supply pressure exceeds 0.1 MPa, the output may malfunction even when operated at the same time.



VR51 Series

Specific Product Precautions 3

Be sure to read this before handling the products.

Refer to back page 50 for Safety Instructions and pages 3 to 9 for 3/4/5 Port Solenoid Valve Precautions.

Operating Environment

Warning

1. Do not use in atmospheres where the valve is in direct contact with corrosive gases, chemicals, salt water, water or steam.
2. Do not use in locations subject to vibration or impact. Confirm the specifications in the main section of the catalog.
3. Use a protective cover, etc., to shield valves from direct sunlight.
4. Shield valves from radiated heat generated by nearby heat sources.
5. Employ suitable protective measures in locations where there is contact with oil or welding spatter, etc.

Caution

1. Avoid using in a place where there is splashing oil, coolant, or water. In addition, avoid using where dust may adhere to it.

Maintenance

Warning

1. Perform maintenance procedures as shown in the operation manual.

If handled improperly, malfunction or damage of machinery or equipment may occur.

2. Removal of equipment and supply/exhaust of compressed air

When equipment is serviced, first confirm that measures are in place to prevent dropping of work pieces and run-away of equipment, etc. Then cut the supply pressure and power, and exhaust all compressed air from the system using its residual pressure release function.

When the equipment is to be started again after remounting or replacement, first confirm that measures are in place to prevent lurching of actuators, etc., and then confirm that the equipment is operating normally.

3. Perform inspections on a regular basis as necessary, such as at the beginning of an operation, to make sure that the VR51 series operates properly.

Failure to observe this precaution could lead to unsafe operation, such as unintended operation or malfunction.

Maintenance

Warning

4. During regular maintenance, check for the following and replace any components as necessary

- a) There are no scratches, corrosion, loose screws, or other visible damage on the valve body.
- b) There is no damage to the One-touch fittings.
- c) There is no damage to tubes, including kinks or flattening.
- d) There is no hardening, deteriorating, or softening of tubes.
- e) There is no air leakage.
- f) The air pressure is in the 0.25 MPa to 1 MPa range.
- g) There is output from the A port of the VR51 when the 2 control devices installed on the IN side are operated simultaneously.
- h) There is no output from the A port of the VR51 when the 2 control devices installed on the IN side are operated more than 0.5 seconds apart.
- i) When the A port of the VR51 is in a state of output, if the operation of one of the control devices is stopped, the output from the A port ceases.

5. Do not repair the fittings or patch the tubing for reuse.

6. Remove drainage from air filters regularly.

Caution on Preparing the Buttons for Manipulation

Caution

1. Design and prepare the buttons in accordance with operation manuals and European directives [Safety of machinery - Two handed control equipment - Functionality aspects - Design principle] (EN574)

If the manipulating buttons are incorrectly arranged, an unexpected motion is likely to occur and the safety cannot be maintained.

VM

VMG

VR

VR51

VHK

VH

VHS □

VHS