

Transmitters: Shuttle Valve with One-touch Fittings VR1210F/1220F



Relay valves for controlling pneumatic signal lines



The air of higher pressure side constantly flows to the OUT side.

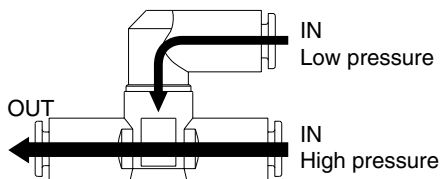
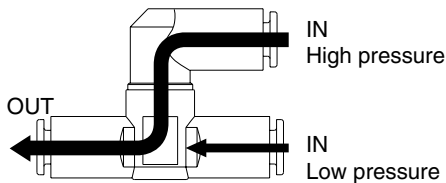

JIS Symbol

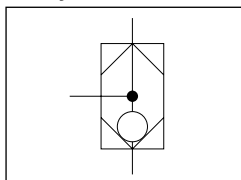

Model

Model	Applicable tubing diameter									
	Metric size					Inch size				
	3.2	4	6	8	10	1/8"	5/32"	1/4"	5/16"	3/8"
VR1210F	●	●	●	●		●	●	●	●	
VR1220F			●	●	●			●	●	●

Specifications

Proof pressure	1.5 MPa
Max. operating pressure	1 MPa
Min. operating pressure	0.05 MPa
Ambient and fluid temperature	-5 to 60°C (No freezing)
Applicable tubing material ⁽¹⁾	Nylon, Soft nylon, Polyurethane

Note 1) Use caution about the maximum operating pressure when soft nylon and polyurethane is used. (Refer to "Best Pneumatics Vol. 15".)

Note 2) Brass components are all electroless nickel plated as standard. (Copper-free)

Flow Rate and Effective Area

Model		VR1210F				VR1220F		
Applicable tubing O.D.	Metric size	ø3.2	ø4	ø6	ø8	ø6	ø8	ø10
	Inch size	ø1/8"	ø5/32"	ø1/4"	ø5/16"	ø1/4"	ø5/16"	ø3/8"
IN → OUT	Flow rate (l/min (ANR))	150	210	420	480	440	680	1000
	Effective area (mm ²)	2.3	3.2	6.4	7.3	6.7	10.4	15.2

Note) Flow rate is the value measured under a pressure of 0.5 MPa and a temperature of 20°C.

How to Order

VR 12 **1** 0 F — **06**

Body size

1	1/8 standard
2	1/4 standard

Shuttle valve

With One-touch fittings

Applicable tubing diameter

Metric size		Inch size	
23	ø3.2*	01	ø1/8"
04	ø4	03	ø5/32"
06	ø6	07	ø1/4"
08	ø8	09	ø5/16"
10	ø10	11	ø3/8"

* For ø3.2, use ø1/8" tubing.

S□A

V□A

S□A

V□A

VM

VR

VH

VHS

Series VR1210F/1220F

Example of Operating Circuit

OR circuit

- If either A or B is turned ON, cylinder is actuated.

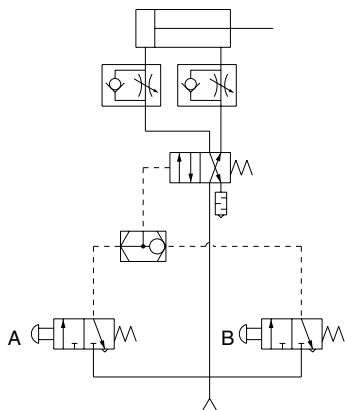

Self-hold circuit

1. If A is turned ON, the output turns ON.
2. Even though A is turned OFF, the output remains in ON state.
3. If B is turned ON in 2. state, the output is turned OFF.

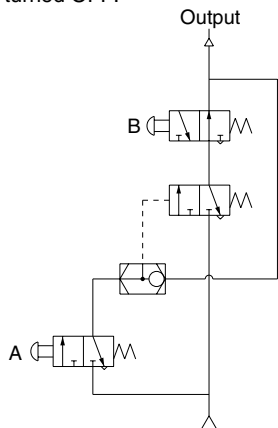

Interlock circuit

- When either A or B is turned ON, even though C turns ON, the output 3 will not be turned ON.

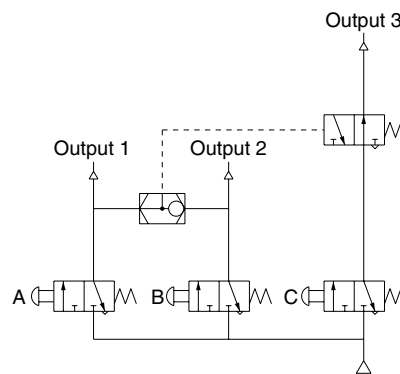

Dimensions

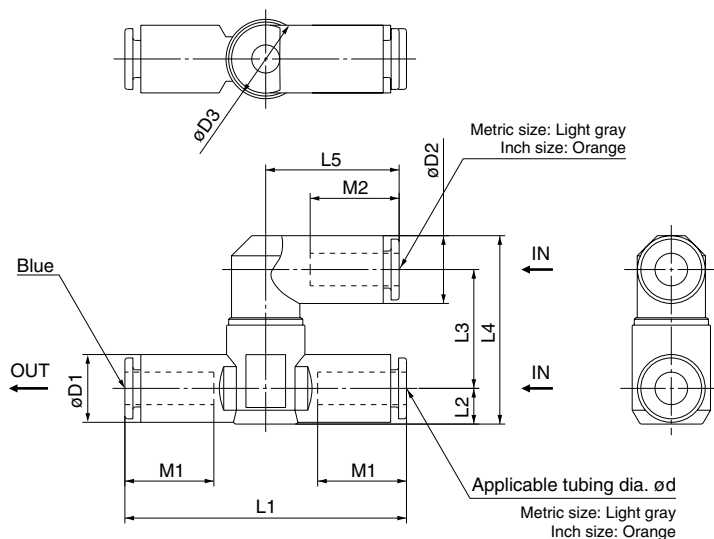

Metric Size

Model	d	D1	D2	D3	L1	L2	L3	L4	L5	M1	M2	Weight (g)
VR1210F-23	3.2	11.4	8.4	14.8	52	6.2	19.4	29.8	17.5	12.7	12.9	21.4
VR1210F-04	4	12.8	10.4		56	6.8	20.3	32.2	21.9	15.7	15.8	25.2
VR1210F-06	6	12.8	12.8		53.2	22.5	35.6	25.2	16.8	16.8	23.0	
VR1210F-08	8	15.2	15.2		60.4		8.1	38.2	28.2	18.7	18.7	24.0
VR1220F-06	6	12.8	12.8	19.8	59	7.4	23.9	37.7	25.2	16.8	16.8	27.2
VR1220F-08	8	15.2	15.2		65	8.2		39.7	28.2	18.7	18.7	31.9
VR1220F-10	10	18.5	18.5		71.6	9.8	25.8	44.8	31	20.8	20.8	43.2

Inch Size

Model	d	D1	D2	D3	L1	L2	L3	L4	L5	M1	M2	Weight (g)
VR1210F-01	1/8"	11.4	8.4	14.8	52	6.2	19.4	29.8	17.5	12.7	12.9	21.4
VR1210F-03	5/32"	12.8	10.4		56	6.8	20.3	32.2	21.9	15.7	15.8	25.2
VR1210F-07	1/4"	13.2	13.2		54.4	7.1	22.5	36.2	25.6	16.8	16.8	23.5
VR1210F-09	5/16"	15.2	15.2		60.4	8.1		38.2	28.2	18.7	18.7	24.0
VR1220F-07	1/4"	13.2	13.2	19.8	59	7.4	23.9	37.9	25.6	16.8	16.8	31.4
VR1220F-09	5/16"	15.2	15.2		65	8.2		39.7	28.2	18.7	18.7	31.9
VR1220F-11	3/8"	17.9	18.5		69.8	9.5	25.8	44.5	31	20.8	20.8	53.0