

Direct Operated Solenoid Valve Metal Seal

Series VS4 □ 10

Model

Number of positions	JIS Symbol	Model	Port size Rc (Nominal size)	Flow characteristics						Max. (1) operating cycle (cpm)		Response (2) time (ms)		Weight (3) (kg)		VK
				P → A/B			A/B → EA/EB			AC	DC	AC	DC	AC	DC	
				C [dm ³ /(s·bar)]	b	Cv	C [dm ³ /(s·bar)]	b	Cv							
2 (Single)		VS4110-01	1/8 (6A)	3.2	0.42	0.86	3.2	0.37	0.80	1,200	180	13 or less	45 or less	0.7	0.82	VZ
		VS4110-02	1/4 (8A)	4.0	0.17	0.91	3.4	0.47	0.89							
		VS4110-03	3/8 (10A)	4.1	0.19	0.96	3.9	0.35	1.00							
2 (Double)		VS4210-01	1/8 (6A)	3.2	0.42	0.86	3.2	0.37	0.80	1,200	180	13 or less	40 or less	0.9	1.14	VFR
		VS4210-02	1/4 (8A)	4.0	0.17	0.91	3.4	0.47	0.89							
		VS4210-03	3/8 (10A)	4.1	0.19	0.96	3.9	0.35	1.00							
3 (3 position)		VS4310-01	1/8 (6A)	3.1	0.37	0.80	3.2	0.35	0.82	360	180	15 or less	45 or less	0.98	1.22	VZS
		VS4310-02	1/4 (8A)	3.8	0.23	0.89	3.6	0.33	0.89							
		VS4310-03	3/8 (10A)	4.2	0.23	1.00	3.8	0.32	0.99							
		VS4410-01	1/8 (6A)	3.1	0.28	0.77	3.0	0.28	0.75	360	180	15 or less	45 or less	0.98	1.22	VFS
		VS4410-02	1/4 (8A)	3.9	0.22	0.94	3.5	0.27	0.84							
		VS4410-03	3/8 (10A)	4.0	0.26	1.00	3.7	0.32	0.94							

- Note 1) Min. operating frequency is once every 30 days. (Based on JIS B 8375.)
 Note 2) Based on JIS B 8375-1981. (At the pressure of 0.5 MPa, without surge suppressor)
 Note 3) Electrical entry: From sub-plate
 Note 4) "Note 1)" and "Note 2)" are with controlled clean air.

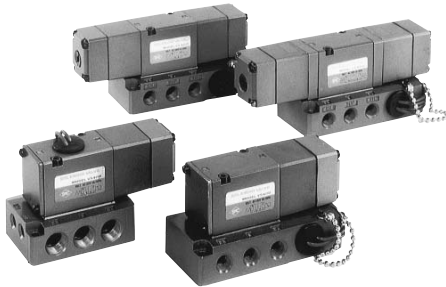

Standard Specifications

Fluid	Air/Inert gas	
Operating pressure range	0 to 1.0 MPa	
Ambient and fluid temperature	-20 to 60°C*	
Manual override	Possible	
Electrical entry	Grommet, Conduit, DIN terminal, Conduit terminal	
Lubrication	Non-lube	Usable with non-lube
	Lubrication	Use turbine oil Class 1 (ISO VG32), if lubricated.
Impact/Vibration resistance (m/s ²)	150/50 (Note)	
Manifold	Possible	

- * Use dry air (Dew point: -20°C or less). If using a lubricant, be sure to use a lubricant for low temperatures.
 Note) Impact resistance: No malfunction occurred when it is tested with a drop tester in the axial direction and at the right angles to the main valve and armature in both energized and de-energized states every once for each condition. (Values at the initial period)
 Vibration resistance: No malfunction occurred in a one-sweep test between 45 and 2000 Hz. Test was performed at both energized and de-energized states in the axial direction and at the right angles to the main valve and armature. (Values at the initial period)

Solenoid Specifications

Coil rated voltage	100, 200 VAC, 50/60 Hz; 24 VDC
Allowable voltage fluctuation	-15 to +10% of rated voltage
Coil insulation type	Class B or equivalent (130°C) (Note)

Note) Based on JIS C 4003

⚠ Caution

For Safety Instructions and Solenoid Valve Precautions, refer to page 3-13-2.

How to Calculate the Flow Rate

For obtaining the flow rate, refer to page 3-1-10.

How to Order

VS 4 1 1 0 - 02 1 C L - □

Direct operated/Metal seal solenoid valve

4, 5 port valve

Type of actuation

1	Single
2	Double
3	3 position (Closed center)
4	3 position (Exhaust center)

Body size: 1/8 standard

Piping

0	Side ported
1	Bottom ported
4	Without sub-plate (For manifold)

Port size (Nominal size)

00	Without sub-plate
01	Rc 1/8 (6A)
02	Rc 1/4 (8A)
03	Rc 3/8 (10A)

Voltage

1	100 VAC, 50/60 Hz
2	200 VAC, 50/60 Hz
5	24 VDC
9	Other

Electrical entry

Symbol	Electrical entry position	Electrical entry
C	Sub-plate	Conduit
T	Sub-plate	Conduit with terminal
U	Valve body	Grommet
D	Valve body	DIN terminal

Thread type

Nil	Rc
N *	NPT
T *	NPTF
F *	—

* Option

Accessory

L	Indicator light (DC is possible only for DL.)
P	Manual override

Series VS4□10

Apparent Power (Power Consumption)

Apparent power (VA) (Power consumption (W))	AC	Inrush	50 Hz	51 VA (64 VA *)
			60 Hz	45 VA (55 VA *)
		Holding	50 Hz	17 VA (5.3/5.5 W)
			60 Hz	11 VA (2.9/3.2 W)
Power consumption (W)	DC			5.5

 * In the case of 3 position type.

Option Specifications

- Bottom ported (Sub-plate)
- Coil rated voltage (110/220 VAC, 12/100 VDC)

Enclosure (Based on JIS C 0920)

Electrical entry	Grommet Sub-plate/ Valve body	Conduit	DIN terminal	Conduit terminal
Dustproof	Standard	Standard	Standard	Standard
Dripproof	—	Option	Option	Option

Construction Principle

VS4110

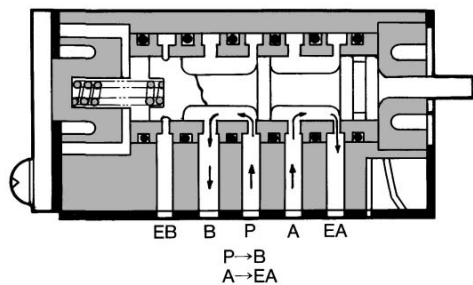

VS4210

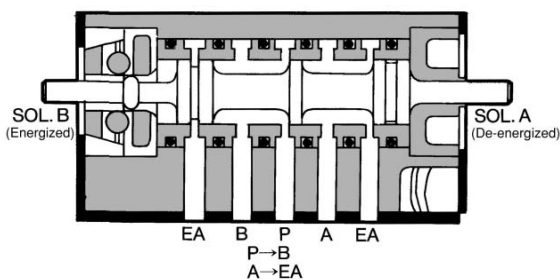

VS4310 (Closed center)

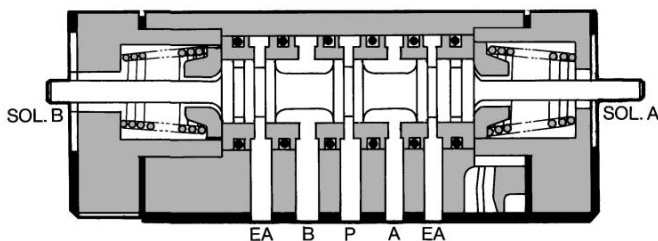

Accessory (Option)

1. Indicator light (AC)

When solenoid gets energized, indicator light illuminates, thus electrical states of the solenoid can be seen from the outside.

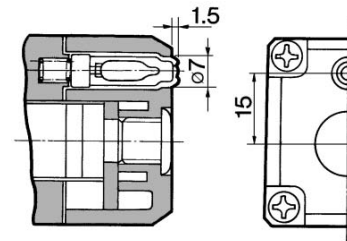

With rubber plug	Manual override		Applicable model
	Non-locking	With lock	
SC0003-□	SC0004B-□	SC0004A-□	VS4110 VS4210
SC0013-□	SC0014B-□	SC0014A-□	VS4310 VS4410

* Indicate the voltage to be used.

2. Manual override

Remove rubber plug at the top of the solenoid cap to install manual override. Push the override with a screwdriver to the required stroke and the valve will shift. With the override in the same position, turn it to the right or left 90° and it will lock. Turn it back 90° to unlock.

⚠ Caution

Be sure to unlock it before energizing the valve electrically.

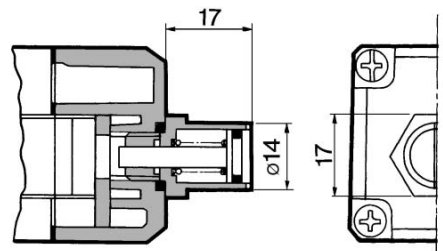

Description	Part no.	Applicable model
Manual override (With lock)	AC PB0111	VS4110 VS4310 VS4410
	DC PB0111-1	
Manual override (Non-locking)	AC PB0101	VS4210
	DC PB0101-1	

(In the case of a 2 position solenoid valve, use a non-locking manual override because it has a locking function in the main valve.)

3. Terminal wiring

- Lead wire from the solenoid is connected to the lower terminal of the terminal block under the junction cover of sub-plate. Connect the lead wire of the power supply corresponding to the solenoid (single solenoid: A side/double solenoid: both A and B sides) to the upper terminal of the terminal block.

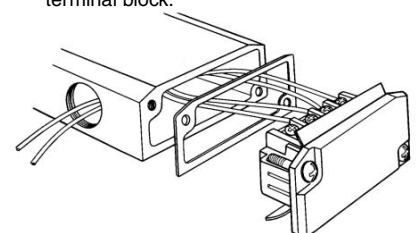

Direct Operated Solenoid Valve Metal Seal Series VS4□10

Construction

VS4110

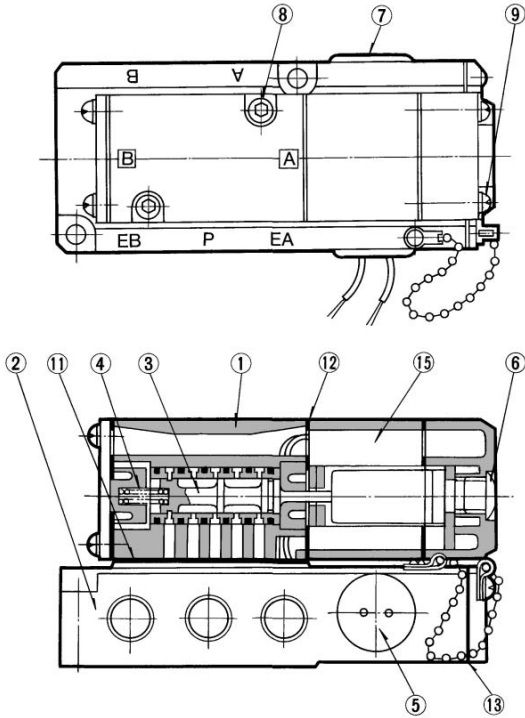

VS4210

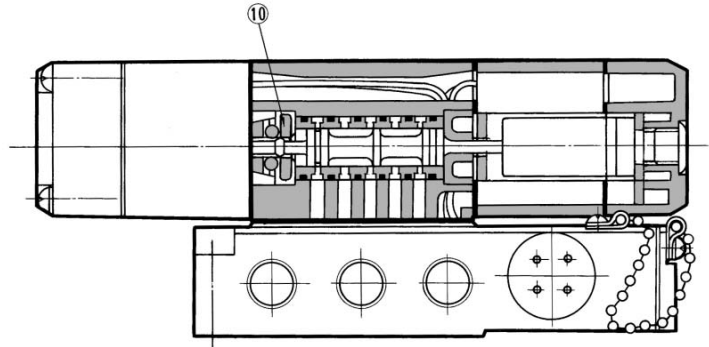

VS4310/4410

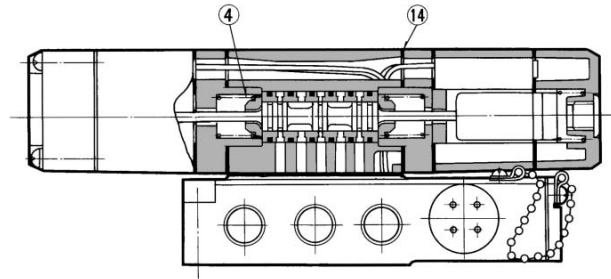

- VK
- VZ
- VF
- VFR
- VP4
- VZS
- VFS
- VS4**
- VQ7
- EVS
- VFN

Sub-plate Assembly Part No.

Electrical entry	Part no.
C: Conduit	VS4010-CS- 01 02 03
T: Conduit terminal	VS4010-TS- 01 02 03
U: Grommet, D: DIN terminal	VS4010-S- 01 02 03

* Mounting bolt and gasket are not included.

Part No. for Mounting Bolt and Gasket

BG-VS4010

Component Parts

No.	Description	Material	Note
①	Body	Aluminum die-casted	Platinum silver
②	Sub-plate	Aluminum die-casted	Platinum silver
③	Spool/Sleeve	Stainless steel	

Replacement Parts

No.	Description	Material	Part no.		
			VS4110	VS4210	VS4310/VS4410
④	Spring	Piano wire	AXT333-9-3	—	AXT333-22-3
⑤	Rubber plug for wire	NBR	XT010-20	XT012-24	XT012-24
⑥	Plug for cap	NBR	AXT333-16	AXT333-16	AXT333-16
⑦	Rubber plug	NBR	AXT333-12	AXT333-12	AXT333-12
⑧	Mounting bolt	Carbon steel	AXT333-17	AXT333-17	AXT333-17
⑨	Mounting screw	Carbon steel	AXT333-19 (AXT333-31-4)	AXT333-19 (AXT333-31-4)	DXT020-36 (AXT333-31-5)
⑩	Detent assembly	NBR	—	AXT333-20	—
⑪	Gasket	NBR	AXT335-12-3	AXT335-12-3	AXT335-12-3
⑫	Gasket	NBR	AXT333-14	AXT333-14	AXT333-14
⑬	Gasket	NBR	AXT333-15	AXT333-15	AXT333-15
⑭	Gasket	NBR	—	—	AXT334-7

(): For DC

⑮ Solenoid Capsule Assembly (With rubber plug)

	Specifications	Part no.	
		VS4110/4210	VS4310/4410
Standard	Grommet/Conduit	SCA001-□	SCA011-□
	DIN terminal	SCAD001-□	SCAD011-□
Option	Indicator light (AC only)	SCA003-□	SCA013-□



* Indicate the used voltage.

Series VS4□10

Dimensions

Grommet (VS4110)

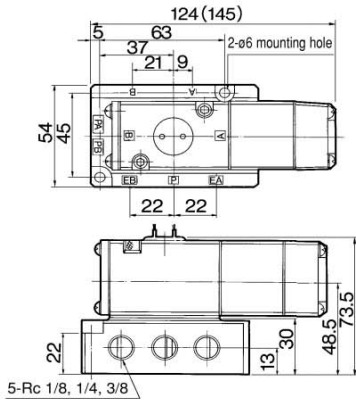

(VS4210)

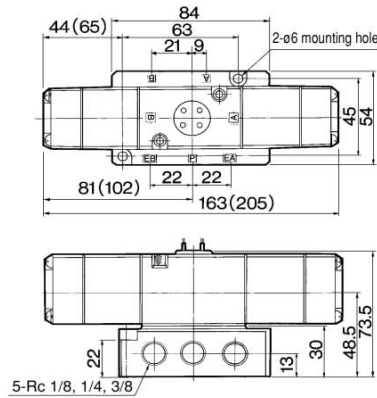

(VS4310/4410)

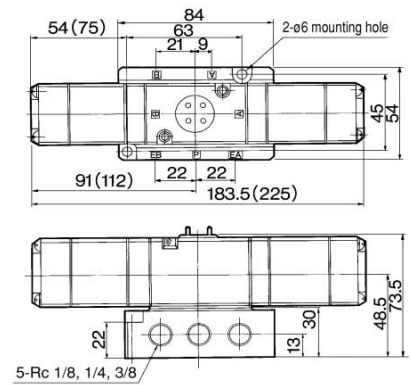

Conduit Conduit terminal (VS4110)

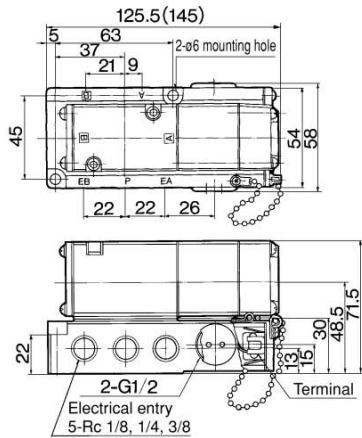

(VS4210)

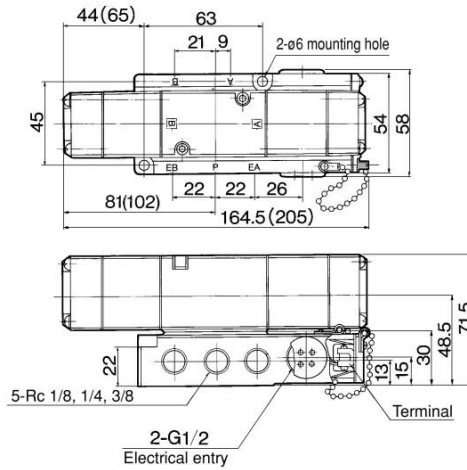

(VS4310/4410)

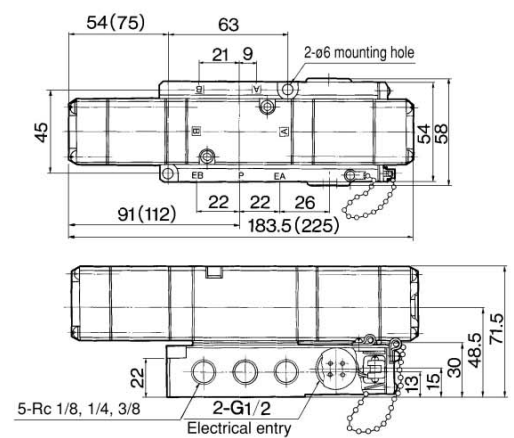

DIN terminal (VS4110)

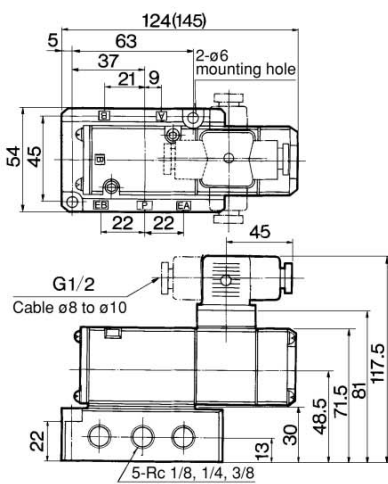

(VS4210)

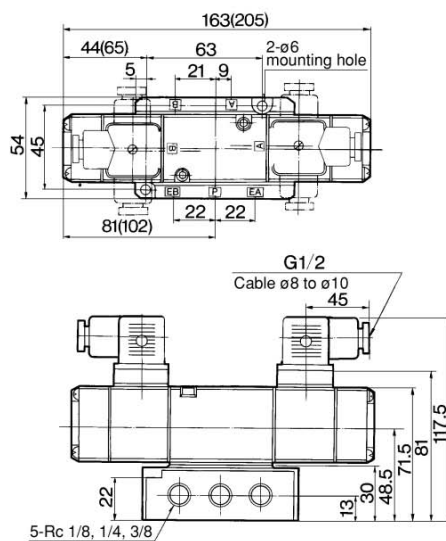

(VS4310/4410)

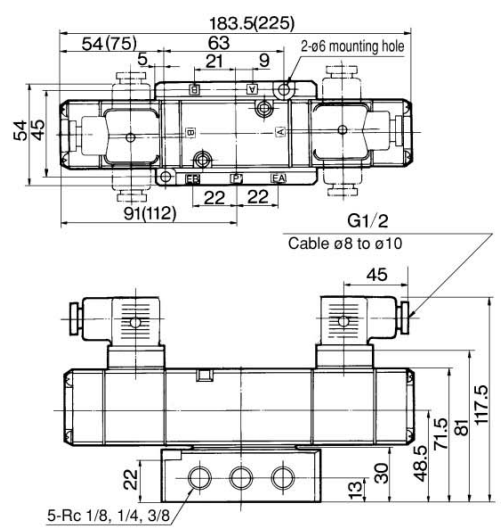

Bottom ported (VS4110)

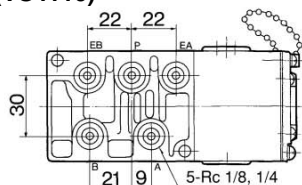

(VS4210)

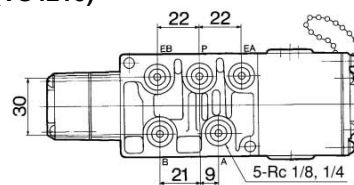

(VS4310/4410)

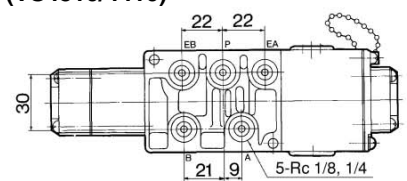

() : DC