

# Unit Manifold Valve

## Compact Direct Operated 3 Port Solenoid Valve



\* Barb fittings are included when no bracket is supplied.

**6 mm** width valve  
Mounting the V060 series

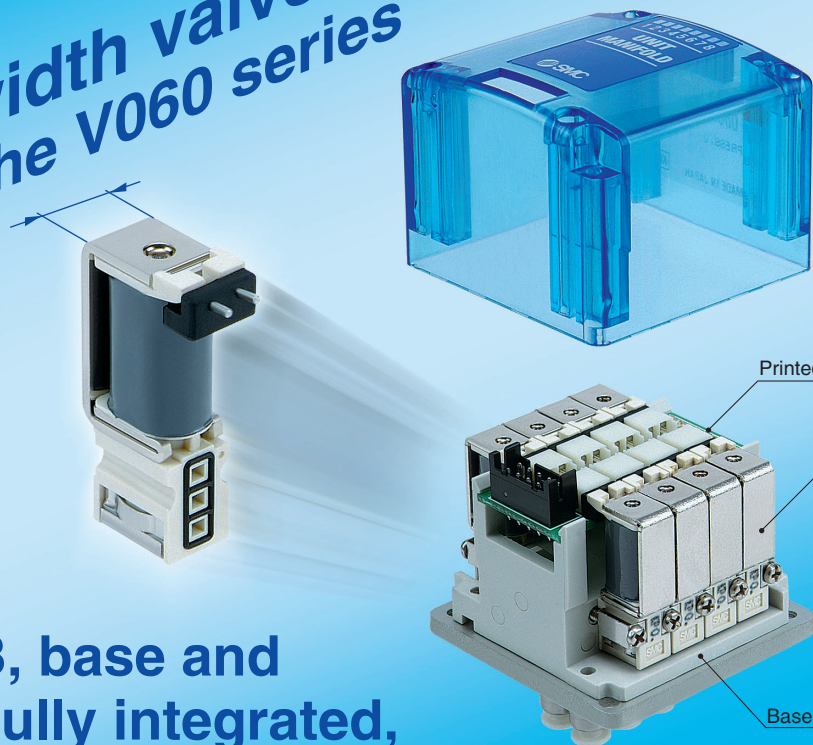

Valves, PCB, base and fittings are fully integrated, forming a single compact unit: A new unit manifold concept.

\* Above picture depicts an 8-station unit manifold.

Series **VV061**

# Unit Manifold

## Able to select one-touch fitting or barb fitting

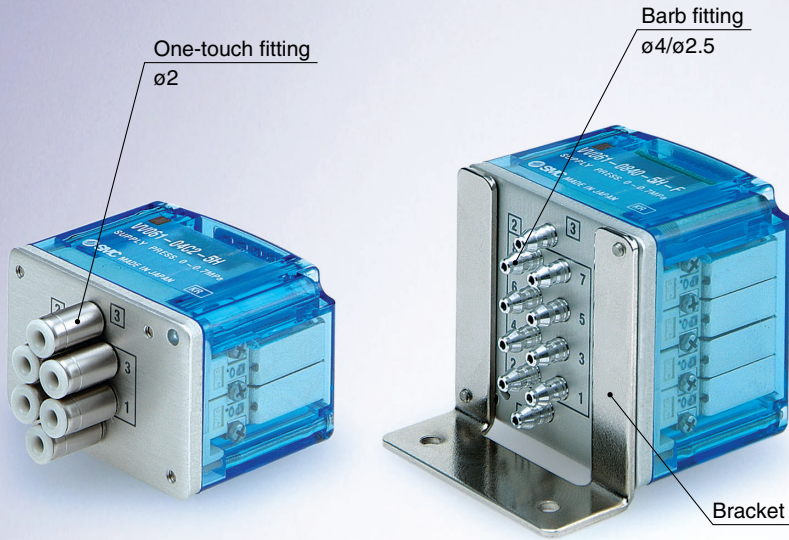

## Mounting

- Bracket mounting
- Panel mounting

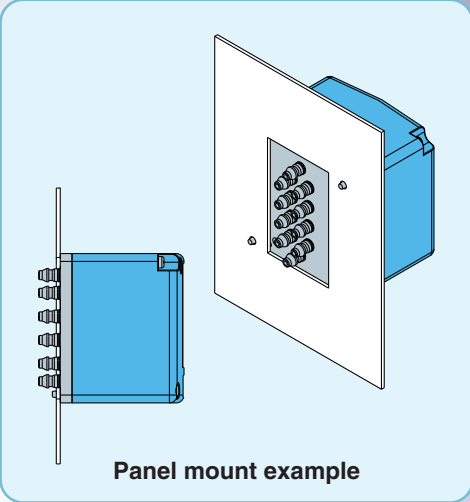

## Lead wire length

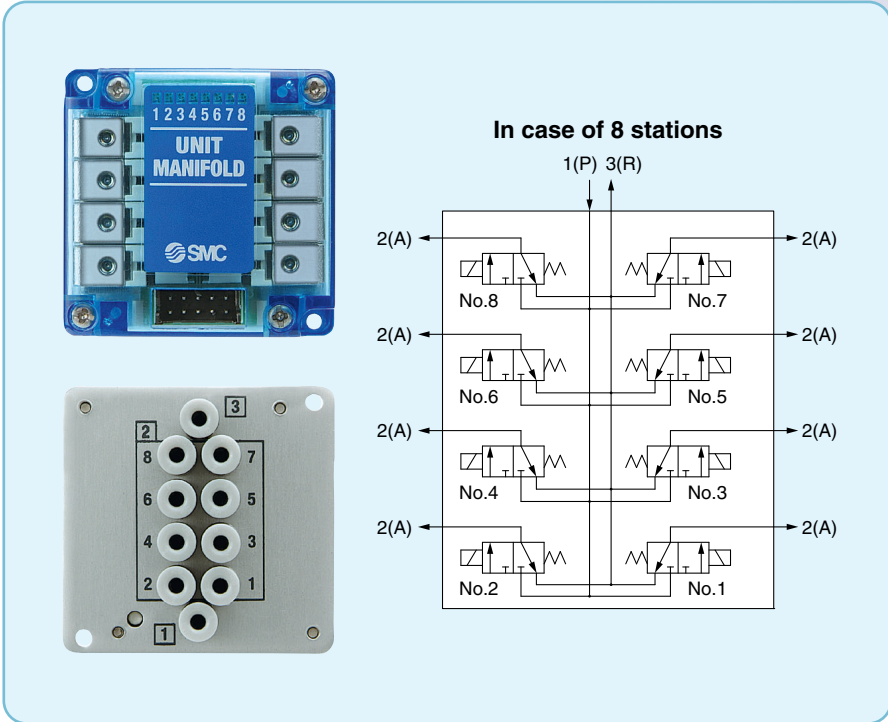
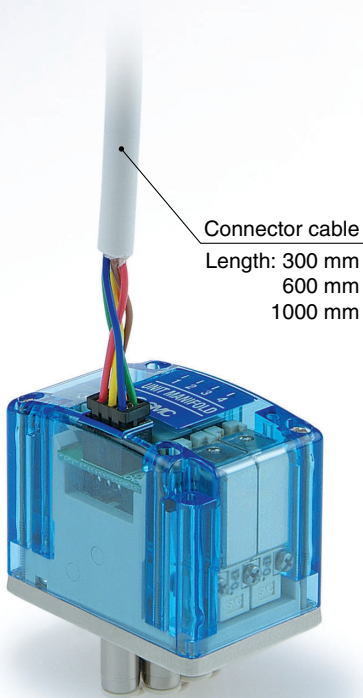

## RoHS compliant reducing environmental impact

# Unit Manifold Valve

## Compact Direct Operated 3 Port Solenoid Valve

# Series VV061



### How to Order

VV061-08 40-5 H-

#### Valve stations

Symbol	Stations
04	4 stations
08	8 stations

#### 1/2/3 port size

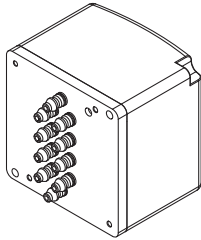
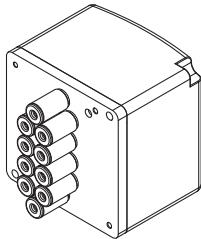
Symbol	Port size
40	Barb fitting (Applicable tubing $\phi 4/\phi 2.5$ ) 
C2	$\phi 2$ one-touch fitting 

Note) The applicable tube of the barb fitting shows the outside/inside tube diameter.

#### Rated voltage

5	24 VDC
6	12 VDC

#### Coil specifications

—	Standard (with light/surge voltage suppressor) +COM
N	Standard (with light/surge voltage suppressor) -COM
T	With power-saving circuit +COM
NT	With power-saving circuit -COM

If the coil will be continuously energized for a long period, be sure to choose the coil with power-saving circuit (Refer to page 2 for details.)

Note 1) Both the standard coil and the coil with power-saving circuit have a light/surge voltage suppressor.

#### Bracket

—: Without bracket  
(2 mounting screws M2 x 27 are included.)

F: With bracket

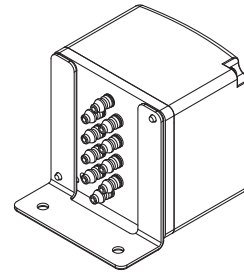

#### Connector cable

—: Without connector cable

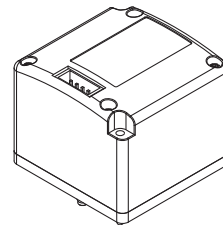

C1: With connector cable (300 mm length)  
C2: With connector cable (600 mm length)  
C3: With connector cable (1000 mm length)

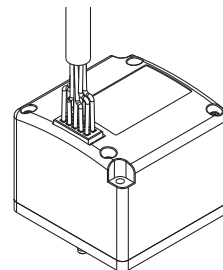

#### Operating pressure range

H	Standard (0 to 0.7 MPa)
L	High flow type (0 to 0.3 MPa)



# Series VV061

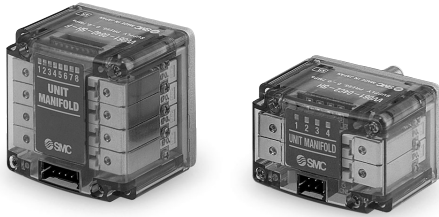

## Unit Manifold Specifications

<b>Fluid</b>		Air	
<b>Operating pressure range (MPa)</b>	<b>Standard</b>	0 to 0.7	
	<b>High flow type</b>	0 to 0.3	
<b>Vacuum specification (MPa)</b>	<b>Standard</b>	1(P) port	3(R) port
		-100 kPa to 0.6	-100 kPa to 0
<b>Vacuum specification (MPa)</b>	<b>High flow type</b>	-100 kPa to 0.2	-100 kPa to 0
	<b>Ambient and fluid temperature (°C)</b>		
<b>Response speed (ms)</b> <sup>Note 1)</sup>			10 ms or less
<b>Max. operating frequency (Hz)</b>			20
<b>Lubrication</b>			Not required
<b>Mounting orientation</b>			Unrestricted
<b>Impact/Vibration resistance (m/s<sup>2</sup>)</b> <sup>Note 2)</sup>			150/30
<b>Enclosure</b>			Dustproof

Note 1) Based on dynamic performance test, JIS B8374-1981(standard type: Coil temperature 20°C, at rated voltage).

Note 2) Impact resistance: No malfunction occurred when it is tested with a drop tester in the axial direction and at the right angles to the main valve and armature in both energized and de-energized states every once for each condition (value in the initial state).

Vibration resistance: No malfunction occurred in one sweep test between 45 and 2000 Hz. Test was performed to axis and right angle directions of the main valve and armature when pilot signal is ON and OFF (Value in the initial state).

The impact/vibration resistance is 50/10 [m/s<sup>2</sup>] for a manifold with a power-saving circuit.

### Symbol

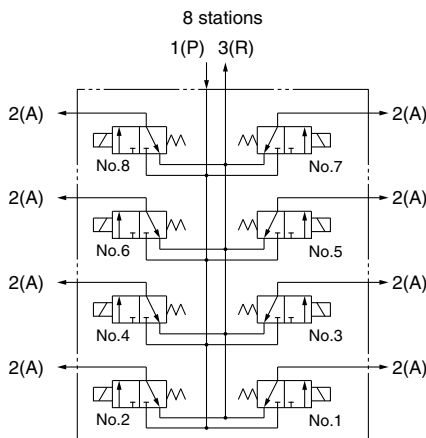
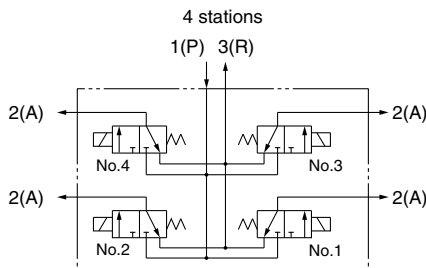

## Solenoid Specifications

<b>Coil rated voltage</b>	12, 24 VDC	
<b>Allowable voltage fluctuation</b> <sup>Note)</sup>	<b>Standard</b>	24 VDC
	<b>Power-saving type</b>	12 VDC
<b>Power consumption (W)</b>	Standard: 0.55	
	With power-saving circuit (continuous duty type): 0.23	
<b>Surge voltage suppressor</b>	Diode	
<b>Indicator light</b>	LED	

Note) The voltage fluctuation should be within the above range in order to prevent voltage drops caused by the internal circuit.

## Flow Characteristics

Type	Effective area (mm <sup>2</sup> )	
	1(P)→2(A)	2(A)→3(R)
Standard	0.07	0.11
High flow type	0.16	0.21

## Weight

Stations	Port size	Weight (g) <sup>Note)</sup>
4 stations	Barb fitting	47 (56)
	ø2 one-touch fitting	53 (62)
8 stations	Barb fitting	75 (85)
	ø2 one-touch fitting	84 (94)

Note) ( ): values with bracket

### Unit Manifold Internal Wiring

#### 4 stations

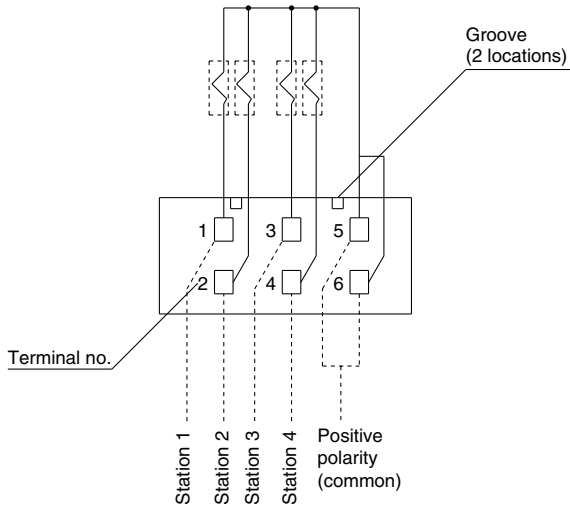

#### 8 stations

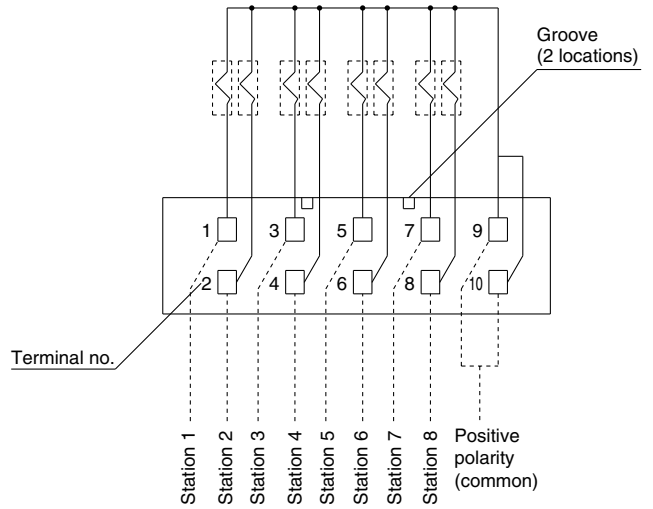

### Connector Cable Specifications

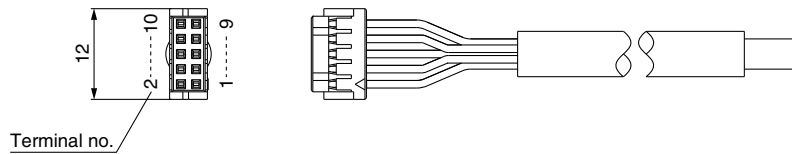

#### Connector Cable Colour List for Each Terminal No.

##### 4 stations

Terminal no.	Lead wire colour
1	Brown
2	Red
3	Orange
4	Yellow
5	Green
6	Blue

##### 8 stations

Terminal no.	Lead wire colour
1	Brown
2	Red
3	Orange
4	Yellow
5	Green
6	Blue
7	Purple
8	Gray
9	White
10	Black

### Construction

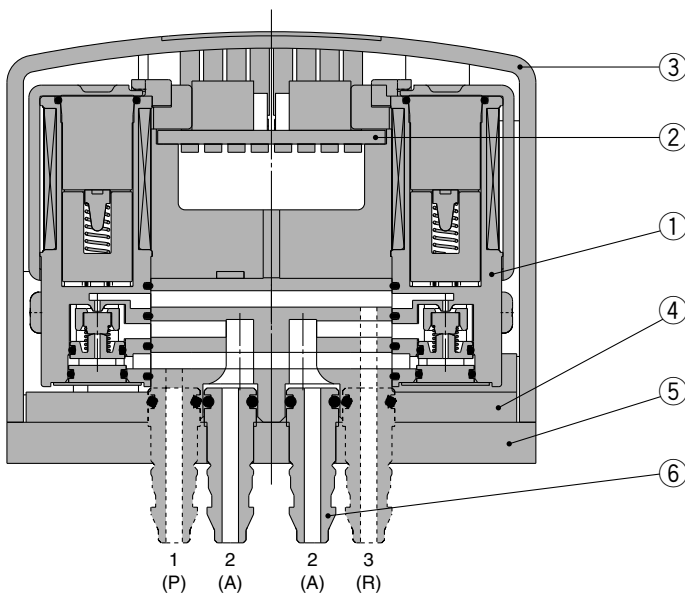

#### Component Parts

No.	Description	Material	Note
1	Solenoid valve	—	Unit assembly (4 mounting screws M2 x 27 L are included.)
2	PCB assembly	—	
3	Cover	Resin	
4	Base	Resin	Plate assembly
5	Plate	Aluminum	
6	Barb fitting	Aluminum	

Note) This internal construction is different from the actual product.

# Series VV061

## Replacement Parts

### ① Unit assembly

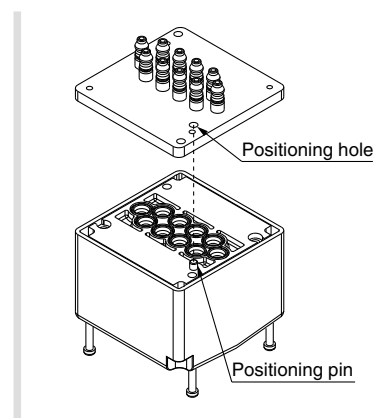
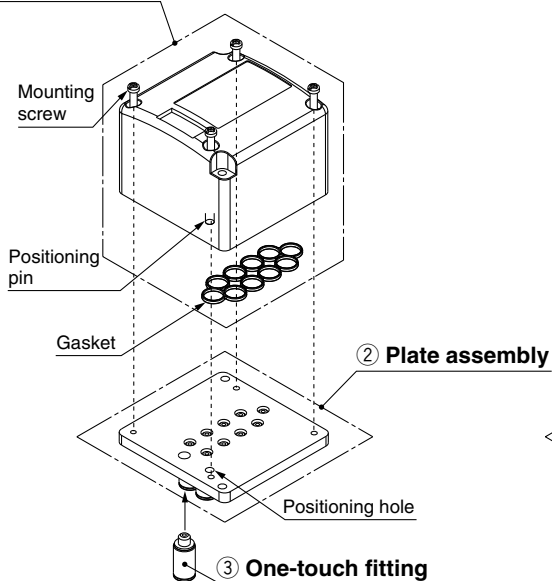

### How to Mount Unit Assembly

Fit the positioning pin of the unit with the positioning hole of the plate, and assemble them.

### ⚠ Caution

Tightening torque: 0.12 N·m

### ① Unit Assembly Part No.

**VV061-0800-5 H**

#### Valve stations

Symbol	Stations
04	4 stations
08	8 stations

#### 1/2/3 port size

Symbol	Port size
00	Without plate assembly

#### Rated voltage

5	24 VDC
6	12 VDC

#### Coil specifications

—	Standard (with light/surge voltage suppressor) +COM
N	Standard (with light/surge voltage suppressor) -COM
T	With power-saving circuit +COM
NT	With power-saving circuit -COM

Note) It is strongly recommended to choose the coil with power-saving circuit if it will be continuously and for long period energised.

#### Operating pressure range

H	Standard (0 to 0.7 MPa)
L	High flow type (0 to 0.3 MPa)

4 mounting screws (M2 x 27 L) and one gasket are included by default.

### ② Plate Assembly Part No.

Stations	Fitting	Barb fitting	One-touch fitting
4 stations		PV060-72-8A	PV060-72-10A
8 stations		PV060-72-7A	PV060-72-9A
Note		Barb fitting is included.	One-touch fitting is mounted on the plate.

### ③ Fitting Part No.

If only the fitting is needed, order with one of the part numbers below.

Description	Barb fitting	One-touch fitting
Part no.	PV060-73-1A	KJS02-M3

Note) The minimum ordering quantity is 10 pcs.

### ④ Bracket Assembly Part No.

Description	Part no.
Bracket (for 4 stations)	PV060-80-2A (Mounting screw included)
Bracket (for 8 stations)	PV060-80-1A (Mounting screw included)

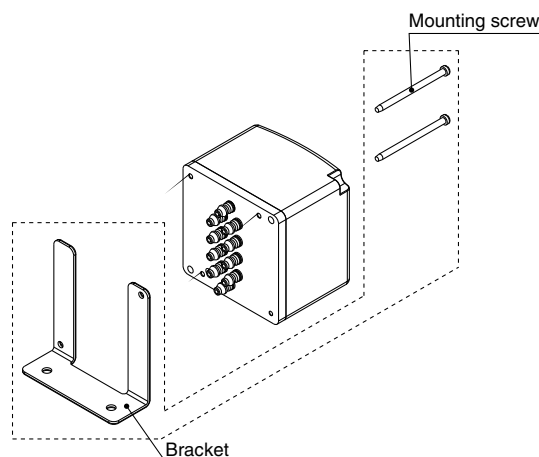

### ⑤ Connector Cable Part No.

For 4 stations **PV060-40-4A-** [ ]

For 8 stations **PV060-40-3A-** [ ]

#### Connector cable length

—	300 mm
6	600 mm
10	1000 mm

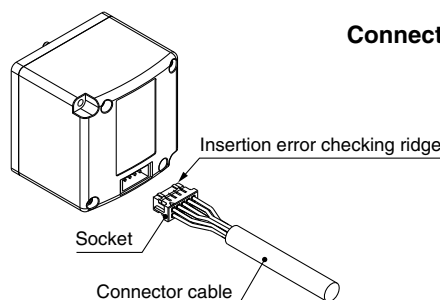

**Dimensions**

**VV061-04**

Cut dimension for panel mount (mounting surface)

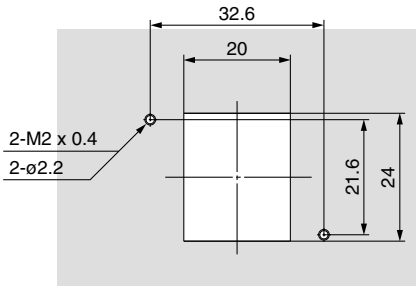

Solenoid valve No.

No. 4  
No. 2

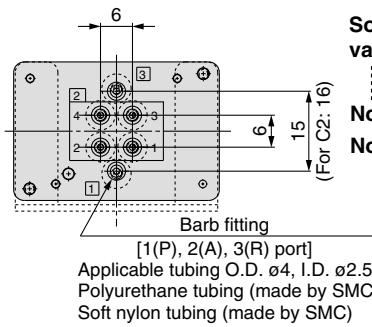

Solenoid valve No.

No. 3  
No. 1

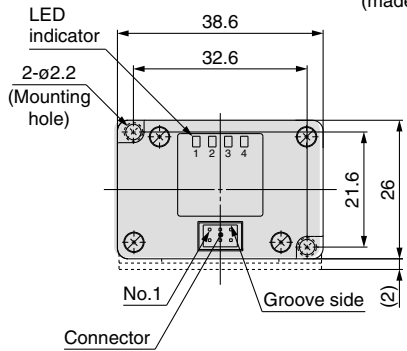
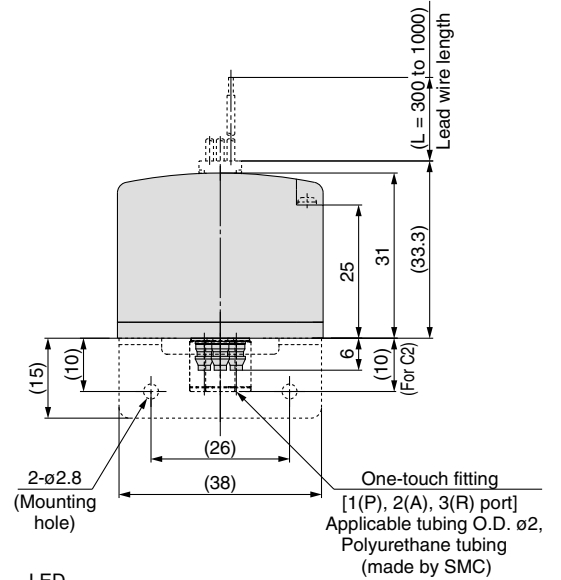
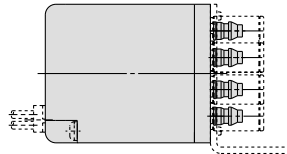

**VV061-08**

Cut dimension for panel mount (mounting surface)

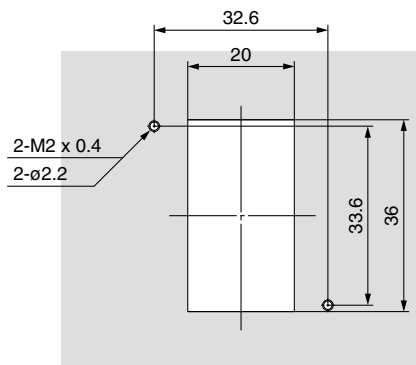

Solenoid valve No.

No. 8  
No. 6  
No. 4  
No. 2

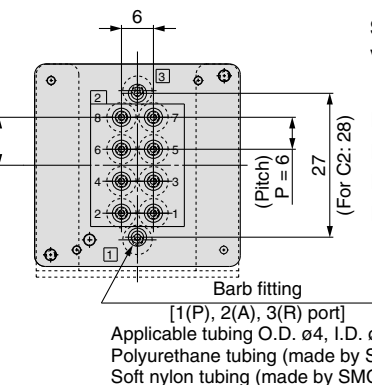

Solenoid valve No.

No. 7  
No. 5  
No. 3  
No. 1

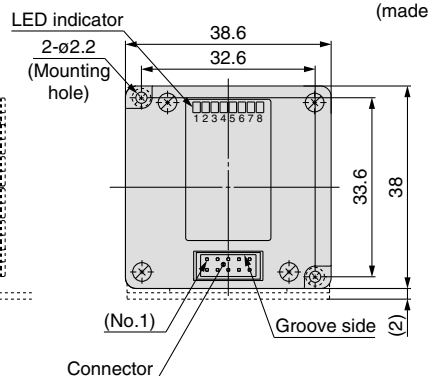
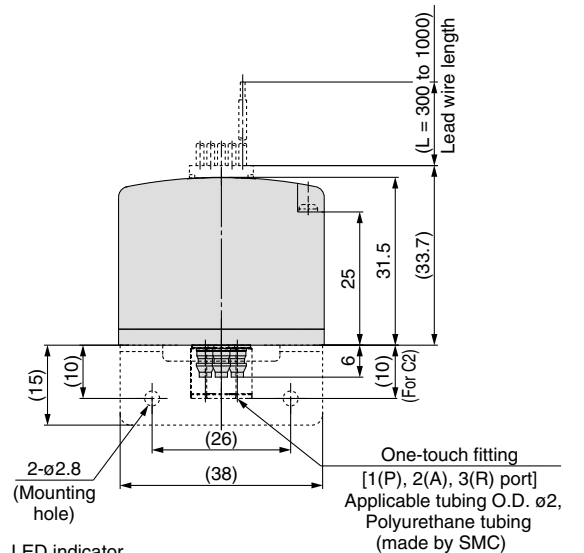
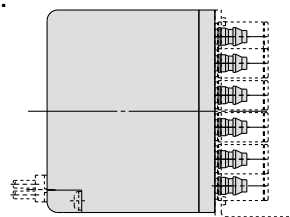





# Safety Instructions

These safety instructions are intended to prevent hazardous situations and/or equipment damage. These instructions indicate the level of potential hazard with the labels of “**Caution,**” “**Warning**” or “**Danger.**” They are all important notes for safety and must be followed in addition to International Standards (ISO/IEC)\*1), and other safety regulations.

- \*1) ISO 4414: Pneumatic fluid power – General rules relating to systems.
- ISO 4413: Hydraulic fluid power – General rules relating to systems.
- IEC 60204-1: Safety of machinery – Electrical equipment of machines. (Part 1: General requirements)
- ISO 10218-1: Manipulating industrial robots - Safety.
- etc.

-  **Caution:** **Caution** indicates a hazard with a low level of risk which, if not avoided, could result in minor or moderate injury.
-  **Warning:** **Warning** indicates a hazard with a medium level of risk which, if not avoided, could result in death or serious injury.
-  **Danger :** **Danger** indicates a hazard with a high level of risk which, if not avoided, will result in death or serious injury.

## Warning

- 1. The compatibility of the product is the responsibility of the person who designs the equipment or decides its specifications.**

Since the product specified here is used under various operating conditions, its compatibility with specific equipment must be decided by the person who designs the equipment or decides its specifications based on necessary analysis and test results. The expected performance and safety assurance of the equipment will be the responsibility of the person who has determined its compatibility with the product. This person should also continuously review all specifications of the product referring to its latest catalog information, with a view to giving due consideration to any possibility of equipment failure when configuring the equipment.
- 2. Only personnel with appropriate training should operate machinery and equipment.**

The product specified here may become unsafe if handled incorrectly. The assembly, operation and maintenance of machines or equipment including our products must be performed by an operator who is appropriately trained and experienced.
- 3. Do not service or attempt to remove product and machinery/equipment until safety is confirmed.**
  1. The inspection and maintenance of machinery/equipment should only be performed after measures to prevent falling or runaway of the driven objects have been confirmed.
  2. When the product is to be removed, confirm that the safety measures as mentioned above are implemented and the power from any appropriate source is cut, and read and understand the specific product precautions of all relevant products carefully.
  3. Before machinery/equipment is restarted, take measures to prevent unexpected operation and malfunction.
- 4. Contact SMC beforehand and take special consideration of safety measures if the product is to be used in any of the following conditions.**
  1. Conditions and environments outside of the given specifications, or use outdoors or in a place exposed to direct sunlight.
  2. Installation on equipment in conjunction with atomic energy, railways, air navigation, space, shipping, vehicles, military, medical treatment, combustion and recreation, or equipment in contact with food and beverages, emergency stop circuits, clutch and brake circuits in press applications, safety equipment or other applications unsuitable for the standard specifications described in the product catalog.
  3. An application which could have negative effects on people, property, or animals requiring special safety analysis.
  4. Use in an interlock circuit, which requires the provision of double interlock for possible failure by using a mechanical protective function, and periodical checks to confirm proper operation.





# Safety Instructions

## Caution

### 1. The product is provided for use in manufacturing industries.

The product herein described is basically provided for peaceful use in manufacturing industries.

If considering using the product in other industries, consult SMC beforehand and exchange specifications or a contract if necessary.

If anything is unclear, contact your nearest sales branch.

## Limited warranty and Disclaimer/Compliance Requirements

The product used is subject to the following “Limited warranty and Disclaimer” and “Compliance Requirements”. Read and accept them before using the product.

### Limited warranty and Disclaimer

#### 1. The warranty period of the product is 1 year in service or 1.5 years after the product is delivered.\*2)

Also, the product may have specified durability, running distance or replacement parts. Please consult your nearest sales branch.

#### 2. For any failure or damage reported within the warranty period which is clearly our responsibility, a replacement product or necessary parts will be provided.

This limited warranty applies only to our product independently, and not to any other damage incurred due to the failure of the product.

#### 3. Prior to using SMC products, please read and understand the warranty terms and disclaimers noted in the specified catalog for the particular products.

##### \*2) Vacuum pads are excluded from this 1 year warranty.

A vacuum pad is a consumable part, so it is warranted for a year after it is delivered.

Also, even within the warranty period, the wear of a product due to the use of the vacuum pad or failure due to the deterioration of rubber material are not covered by the limited warranty.

### Compliance Requirements

#### 1. The use of SMC products with production equipment for the manufacture of weapons of mass destruction (WMD) or any other weapon is strictly prohibited.

#### 2. The exports of SMC products or technology from one country to another are governed by the relevant security laws and regulations of the countries involved in the transaction. Prior to the shipment of a SMC product to another country, assure that all local rules governing that export are known and followed.



# Series VV061

## Specific Product Precautions 1

Be sure to read this before handling.

For Safety Instructions, refer to "Precautions for Handling Pneumatic Devices" (M-03-E3A).

### Selection

#### Warning

##### 1. Extended period being continuously energised

- If a valve will be continuously energised for an extended period of time, the temperature of the valve will increase due to the heat generated by the coil. This will likely adversely affect the performance of the solenoid valve and any nearby peripheral equipment. Therefore, when it is continuously energised or the energised period per day is longer than the de-energised period, use the valves with power-saving circuit.
- For applications such as mounting a valve on a control panel, make sure the heat radiation fits within the operating temperature range.

### How to Use Plug in Connector

#### Caution

##### 1. Attaching and detaching connectors

- 1) To attach a connector  
Insert the connector cable to the end of the socket with the insertion error checking ridge facing upward.  
Then pull the connector cable and check that it does not come out.
- 2) To detach a connector  
Remove the socket from the unit manifold by gripping the socket of the connector cable.  
If excessive force is applied to the connector cable, the connector may come off (do not apply a force of 20 N or more to the lead wire).

### Connector Cable Length

#### Caution

1. Standard length is 300 mm, but more lengths are also available.

#### How to Order Connector Assembly

For 4 stations PV060-40-4A-

For 8 stations PV060-40-3A-

Connector cable length

Nil	300 mm
6	600 mm
10	1000 mm

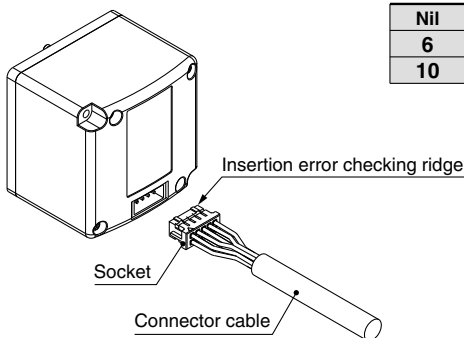

### Surge Voltage Suppressor

#### Caution

##### Positive common specification

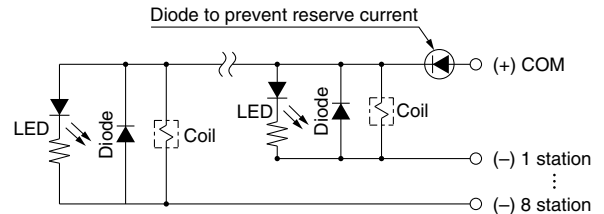

##### Negative common specification

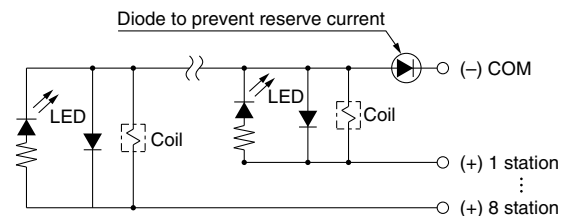

- Since 12 voltage specification does not have diodes for polarity protection, be careful not to confuse with polarity.
- Please use caution regarding the allowable voltage fluctuation because there is about a 1 volt drop for a valve with polarity protection. (For details, refer to the solenoid specifications for the individual valve.)

##### With power-saving circuit

Power consumption is decreased to approx. 1/2 by reducing the wattage required to hold the valve in an energized state. (Effective energizing time is over 62 ms.)

##### Electric circuit (with power-saving circuit) single solenoid, for positive common specification

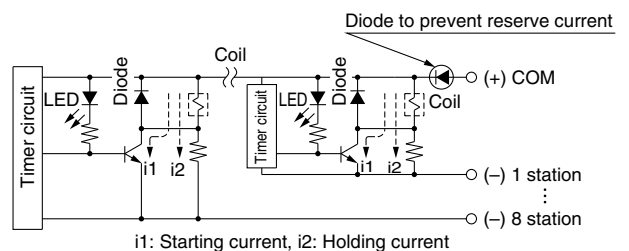

##### Electric circuit (with power-saving circuit) single solenoid, for negative common specification

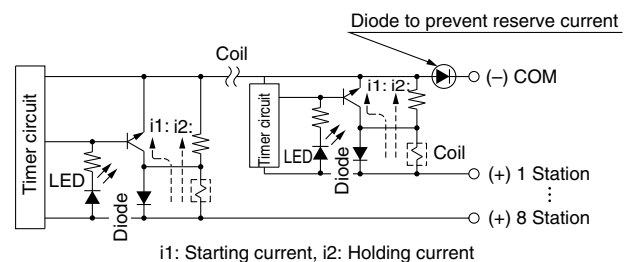

Remarks:

- 1) Impact and vibration should not be more than 50/10 [m/s<sup>2</sup>].
- 2) Voltage fluctuation for 24 VDC should be within the range of -5% to +10% of the rated voltage, and for 12 VDC should be within the range of -6% to +10% of the rated voltage.



# Series VV061

## Specific Product Precautions 2

Be sure to read this before handling.

For Safety Instructions, refer to "Precautions for Handling Pneumatic Devices" (M-03-E3A).

### Working Principle

#### ⚠ Caution

1. With the above circuit, the current consumption when holding is reduced to save energy. Please refer to the electric wave data below.

Electric wave form of power-saving type  
(In case of VV061-□□□□-□T)

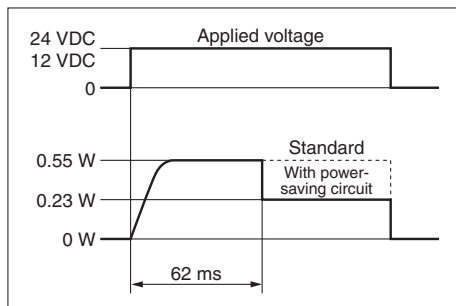

- Please be careful not to reverse the polarity, since the diode to prevent the reversed current is not provided for the 12 VDC specification.
- Please be careful regarding the allowable voltage fluctuation because there is about a 0.5 volt drop due to the transistor.

### Mounting

#### ⚠ Caution

1. **Tightening the threaded portion of an M3 fitting**  
For KJS02-M3 (One-touch fitting), tighten it with a tightening tool by approx. 1/4 rotation after screwing it in by hand. Screwing the fitting in too far will cause air leakage due to thread breakage and gasket deformation. Screwing the fitting not far enough will also cause air leakage due to the loose screw.  
A reference value for the tightening torque is 0.4 to 0.5 N·m.

### One-touch Fittings Precautions

#### ⚠ Caution

1. **Tubing insertion / removal from one-touch fittings**
  - 1) **Attaching of tubing**
    - (1) Cut the tubing perpendicularly, being careful not to damage the outside surface. Use an SMC tubing cutter "TK-1", "TK-2" or "TK-3". (do not cut the tube with pliers, nippers, scissors, etc). If cutting is done with tools other than tube cutters, the tube could be cut diagonally or become flattened, etc., making impossible a secure installation, and causing problems such as the tube pulling out after installation or existence of air leakage. Also allow some extra length in the tube.
    - (2) Slowly push the tube into the one-touch fitting until it stops.
    - (3) Pull the tubing back gently to make sure it has a positive seal. A faulty installation may cause air leakage or tube release.
  - 2) **Removing of tubing**
    - (1) Push flange evenly and push the release bushing sufficiently.
    - (2) Pull out the tube while keeping the release button depressed. If the release bushing is not held down sufficiently, the tube cannot be withdrawn.
    - (3) To reuse the tubing, remove the previously lodged portion of the tube. If the lodged portion is left on without being removed, it may result in air leakage and difficulty in tube removal.

### Other Tubing Brands

#### ⚠ Caution



1. **When using other than SMC brand tubing, confirm that the following specifications are satisfied with respect to the outside diameter tolerance of the tubing.**

- |                        |                                     |
|------------------------|-------------------------------------|
| 1) Soft nylon tubing   | within 0.1 mm                       |
| 2) Polyurethane tubing | within +0.15 mm,<br>within -0.2 mm. |

Do not use tubing which does not meet these outside diameter tolerances. It may not be possible to connect them, or they may cause other trouble, such as air leakage or the tubing pulling out after connection.

## Safety Instructions

These safety instructions are intended to prevent hazardous situations and/or equipment damage. These instructions indicate the level of potential hazard with the labels of “Caution,” “Warning” or “Danger.” They are all important notes for safety and must be followed in addition to International Standards (ISO/IEC) <sup>1)</sup>, and other safety regulations.

-  **Caution:** **Caution** indicates a hazard with a low level of risk which, if not avoided, could result in minor or moderate injury.
-  **Warning:** **Warning** indicates a hazard with a medium level of risk which, if not avoided, could result in death or serious injury.
-  **Danger:** **Danger** indicates a hazard with a high level of risk which, if not avoided, will result in death or serious injury.

- 1) ISO 4414: Pneumatic fluid power – General rules relating to systems.
- ISO 4413: Hydraulic fluid power – General rules relating to systems.
- IEC 60204-1: Safety of machinery – Electrical equipment of machines. (Part 1: General requirements)
- ISO 10218-1: Manipulating industrial robots - Safety. etc.

## Warning

### 1. The compatibility of the product is the responsibility of the person who designs the equipment or decides its specifications.

Since the product specified here is used under various operating conditions, its compatibility with specific equipment must be decided by the person who designs the equipment or decides its specifications based on necessary analysis and test results. The expected performance and safety assurance of the equipment will be the responsibility of the person who has determined its compatibility with the product. This person should also continuously review all specifications of the product referring to its latest catalogue information, with a view to giving due consideration to any possibility of equipment failure when configuring the equipment.

### 2. Only personnel with appropriate training should operate machinery and equipment.

The product specified here may become unsafe if handled incorrectly. The assembly, operation and maintenance of machines or equipment including our products must be performed by an operator who is appropriately trained and experienced.

### 3. Do not service or attempt to remove product and machinery/equipment until safety is confirmed.

1. The inspection and maintenance of machinery/equipment should only be performed after measures to prevent falling or runaway of the driven objects have been confirmed.
2. When the product is to be removed, confirm that the safety measures as mentioned above are implemented and the power from any appropriate source is cut, and read and understand the specific product precautions of all relevant products carefully.
3. Before machinery/equipment is restarted, take measures to prevent unexpected operation and malfunction.

### 4. Contact SMC beforehand and take special consideration of safety measures if the product is to be used in any of the following conditions.

1. Conditions and environments outside of the given specifications, or use outdoors or in a place exposed to direct sunlight.
2. Installation on equipment in conjunction with atomic energy, railways, air navigation, space, shipping, vehicles, military, medical treatment, combustion and recreation, or equipment in contact with food and beverages, emergency stop circuits, clutch and brake circuits in press applications, safety equipment or other applications unsuitable for the standard specifications described in the product catalogue.
3. An application which could have negative effects on people, property, or animals requiring special safety analysis.
4. Use in an interlock circuit, which requires the provision of double interlock for possible failure by using a mechanical protective function, and periodical checks to confirm proper operation.

## Caution

### 1. The product is provided for use in manufacturing industries.

The product herein described is basically provided for peaceful use in manufacturing industries. If considering using the product in other industries, consult SMC beforehand and exchange specifications or a contract if necessary. If anything is unclear, contact your nearest sales branch.

## Limited warranty and Disclaimer/Compliance Requirements

The product used is subject to the following “Limited warranty and Disclaimer” and “Compliance Requirements”. Read and accept them before using the product.

### Limited warranty and Disclaimer

1. The warranty period of the product is 1 year in service or 1.5 years after the product is delivered, whichever is first. <sup>2)</sup> Also, the product may have specified durability, running distance or replacement parts. Please consult your nearest sales branch.
2. For any failure or damage reported within the warranty period which is clearly our responsibility, a replacement product or necessary parts will be provided. This limited warranty applies only to our product independently, and not to any other damage incurred due to the failure of the product.
3. Prior to using SMC products, please read and understand the warranty terms and disclaimers noted in the specified catalogue for the particular products.
- 2) Vacuum pads are excluded from this 1 year warranty. A vacuum pad is a consumable part, so it is warranted for a year after it is delivered. Also, even within the warranty period, the wear of a product due to the use of the vacuum pad or failure due to the deterioration of rubber material are not covered by the limited warranty.

### Compliance Requirements

1. The use of SMC products with production equipment for the manufacture of weapons of mass destruction (WMD) or any other weapon is strictly prohibited.
2. The exports of SMC products or technology from one country to another are governed by the relevant security laws and regulations of the countries involved in the transaction. Prior to the shipment of a SMC product to another country, assure that all local rules governing that export are known and followed.

## Caution

### SMC products are not intended for use as instruments for legal metrology.

Measurement instruments that SMC manufactures or sells have not been qualified by type approval tests relevant to the metrology (measurement) laws of each country. Therefore, SMC products cannot be used for business or certification ordained by the metrology (measurement) laws of each country.

## Safety Instructions

Be sure to read “Handling Precautions for SMC Products” (M-E03-3) before using.

## SMC Corporation (Europe)

<b>Austria</b>	+43 (0)2262622800	www.smc.at	office@smc.at
<b>Belgium</b>	+32 (0)33551464	www.smc.be	info@smc.be
<b>Bulgaria</b>	+359 (0)2807670	www.smc.bg	office@smc.bg
<b>Croatia</b>	+385 (0)13707288	www.smc.hr	office@smc.hr
<b>Czech Republic</b>	+420 541424611	www.smc.cz	office@smc.cz
<b>Denmark</b>	+45 70252900	www.smc.dk.com	smc@smcdk.com
<b>Estonia</b>	+372 651 0370	www.smcee.ee	info@smcee.ee
<b>Finland</b>	+358 207513513	www.smc.fi	smcffi@smc.fi
<b>France</b>	+33 (0)164761000	www.smc-france.fr	supportclient@smc-france.fr
<b>Germany</b>	+49 (0)61034020	www.smc.de	info@smc.de
<b>Greece</b>	+30 210 2717265	www.smchellas.gr	sales@smchellas.gr
<b>Hungary</b>	+36 23513000	www.smc.hu	office@smc.hu
<b>Ireland</b>	+353 (0)14039000	www.smcautomation.ie	sales@smcautomation.ie
<b>Italy</b>	+39 03990691	www.smcitalia.it	mailbox@smcitalia.it
<b>Latvia</b>	+371 67817700	www.smc.lv	info@smc.lv

<b>Lithuania</b>	+370 5 2308118	www.smclt.lt	info@smclt.lt
<b>Netherlands</b>	+31 (0)205318888	www.smc.nl	info@smc.nl
<b>Norway</b>	+47 67129020	www.smc-norge.no	post@smc-norge.no
<b>Poland</b>	+48 222119600	www.smc.pl	office@smc.pl
<b>Portugal</b>	+351 214724500	www.smc.eu	apoioclientept@smc.smces.es
<b>Romania</b>	+40 213205111	www.smcromania.ro	smcromania@smcromania.ro
<b>Russia</b>	+7 (812)3036600	www.smc.eu	sales@smcru.com
<b>Slovakia</b>	+421 (0)413213212	www.smc.sk	office@smc.sk
<b>Slovenia</b>	+386 (0)73885412	www.smc.si	office@smc.si
<b>Spain</b>	+34 945184100	www.smc.eu	post@smc.smces.es
<b>Sweden</b>	+46 (0)86031240	www.smc.nu	smc@smc.nu
<b>Switzerland</b>	+41 (0)523963131	www.smc.ch	info@smc.ch
<b>Turkey</b>	+90 212 489 0 440	www.smcturkey.com.tr	info@smcturkey.com.tr
<b>UK</b>	+44 (0)845 121 5122	www.smc.uk	sales@smc.uk

**South Africa** +27 10 900 1233    www.smcza.co.za    zasales@smcza.co.za