

3 Port Solenoid Valve

Highly Integrated Unit Manifold

2 direct-operated 3-port valves on **1** station

Individually wired valve can be added.

Connector
(For plug-in connection)

Ø2 One-touch fitting connection is possible.

D-sub connector
Number of connectors: 15 pins, 26 pins (for plug-in connection)
• Connector entry direction

Upward

Lateral

SUP/EXH block fittings
• Fitting entry direction

Standard
(Same direction as the cylinder ports)

Side

Plug-in Connector type manifold

Non Plug-in Individual wiring manifold

Series **VV100**



CAT.ES11-98A

Compact manifold with two 3-port valves on 1 station

Scale: 100%



L: Dimensions

Stations	1	2	3	4	5	6	7	8	9	10	11	12
L	34.2	44.4	54.6	64.8	75	85.2	95.4	105.6	115.8	126	136.2	146.4

Mounting

Direct mounting

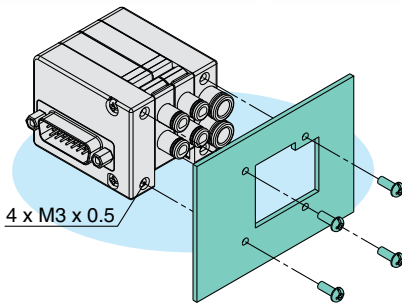

Bracket mounting

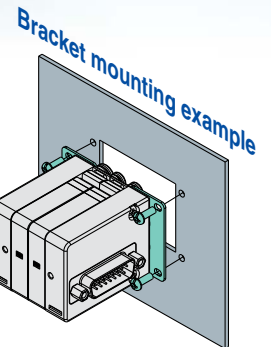
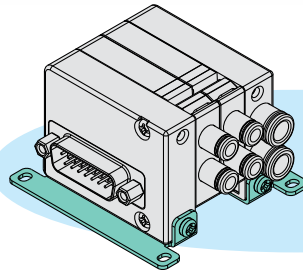

Piping Variations

- Metric size: $\varnothing 2$, $\varnothing 4$ one-touch fitting
- Inch size: $\varnothing 1/8$ ", $\varnothing 5/32$ " one-touch fitting

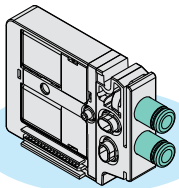

Straight fitting

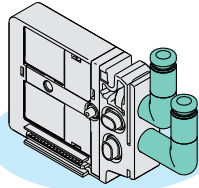

Elbow fitting
(Upward entry)

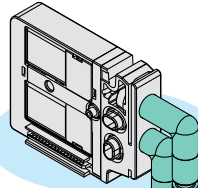

Elbow fitting
(Downward entry)

With Switch

Possible to shut the signal of each valves individually.

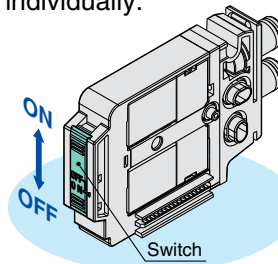

- The valve coil is not energized even if an electric signal is fed by the manifold's connector.
- Effective use as a safety measure for maintenance.

Applications

- 1 Operating a small bore size cylinder such as a pin cylinder
- 2 Air-operated valve for chemical valve



I N D E X

Common Specifications	P.2
Construction	P.3

Plug-in Connector Type Manifold



How to Order	P.4, 5
Manifold Electrical Wiring	P.6
Connector Wiring Diagram	P.6
Dimensions	P.7 to 11

Non Plug-in Individual Wiring Manifold



How to Order	P.12, 13
Dimensions	P.14, 15

Manifold Exploded View	P.16
Manifold Options	P.17 to 19
Safety Instructions	Back page 1, 2
Specific Product Precautions	Back page 3 to 7



Manifold Specifications

Model	D-sub connector		Non plug-in
	Type 10FA	Type 10FB	Type 10
Manifold type	Connector type		Individual wiring
1 (SUP), 3 (EXH)	Common SUP, EXH		
Valve stations	1 to 12 stations (Max. 7 stations if all valves have double solenoid.)	1 to 12 stations	1 to 12 stations
Applicable connector	D-sub connector 15 pins	D-sub connector 26 pins	
Internal wiring	Refer to page 19.		
2a, 2b port piping specification	Location	Valve	
	Direction	Side, Upward, Downward (Using elbow fittings for upward or downward)	
Port size	1 (SUP), 3 (EXH) port	C4, C6, N3, N7	
	2a, 2b port	C2, C4, N1, N3	
Mass W (g) n: Valve stations	W = 56 + n		

* The mass W is the value for the manifold only. (It is applied when the SUP/EXH block fitting is straight type.)
The mass of solenoid valve should be added by the number of stations.

Solenoid Valve Specifications

Fluid	Air		
Operating pressure range (MPa)	Positive pressure		0 to 0.7
	Vacuum pressure	N.C.	1 port: -100 kPa to 0.6/3 ports: -100 kPa to 0
N.O.		1 port: -100 kPa to 0/3 ports: -100 kPa to 0.6	
Ambient and fluid temperature (°C)	-10 to 50 (No freezing)		
Maximum operating frequency (Hz)	20		
Lubrication	Not required		
Mounting orientation	Unrestricted		
Shock/Vibration resistance (m/s²) <small>Note 1)</small>	150/30		
Enclosure	Dustproof		
Coil rated voltage	24 VDC, 12 VDC		
Allowable voltage fluctuation	±10% of rated voltage <small>Note 2)</small>		
Power consumption (W)	Standard	0.4	
	With power saving circuit (Continuous duty type)	0.15	
Surge voltage suppressor	Diode		
Indicator light	LED		

Note 1) Impact resistance: No malfunction occurred when it is tested with a drop tester in the axial direction and at the right angles to the main valve and armature in both energized and de-energized states every once for each condition. (Value in the initial state)

Vibration resistance: No malfunction occurred in one sweep test between 45 and 2000Hz. Test was performed in the axial direction and at the right angles to the main valve and armature in both energized and de-energized states for each condition. (Value in the initial state)

Note 2) For the allowable voltage fluctuation for Z and T types (with power saving circuit), observe the following range because there is voltage drop due to internal circuit.

Z type 24 VDC: -7% to +10% T type 24 VDC: -5% to +10%
12 VDC: -4% to +10% 12 VDC: -6% to +10%

Response Time

Response time ms (at 0.5 MPa)
7 or less

Mass

Valve model	Number of solenoids	Port size	Mass (g)
V110□-C2/C4	1 pc. (Single)	C2, C4	31
	2 pcs. (Double)	(ø2, ø4 one-touch fitting)	40

Flow Characteristics

Port size		Flow characteristics			
1(P)	2a, 2b	1(P)→2a/2b		2a/2b→3(E)	
		C [dm ³ /(s·bar)]	b	C [dm ³ /(s·bar)]	b
C6	C2	0.03	0.22	0.05	0.31
	C4	0.03	0.19	0.05	0.29

* The effective area S (mm²) is approximately 5 times as large as the sonic conductance (S = C x 5).

Construction

Single

JIS symbol

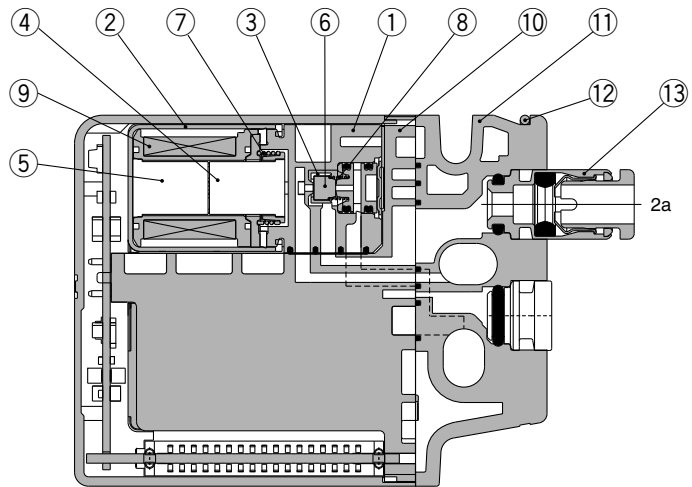
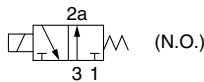
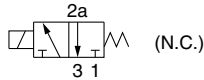

Double

JIS symbol

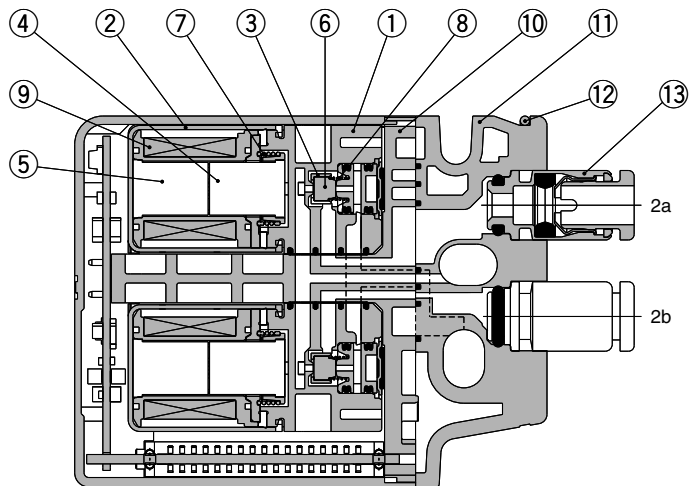
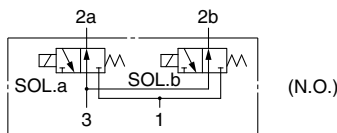
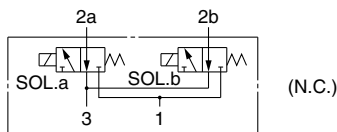

Component Parts

No.	Description	Material
1	Body	Resin
2	Cover	Stainless steel
3	Push rod	Resin
4	Armature assembly	Stainless steel/Resin
5	Core	Stainless steel
6	Poppet	FKM
7	Return spring	Stainless steel
8	Poppet spring	Stainless steel
9	Coil assembly	—
10	Pilot adapter	Resin
11	Port block	Resin
12	Clip	Stainless steel

Replacement Parts

One-touch Fitting (Metric Size)

No.	Port	Port size	Part no.
13	2a, 2b	ø2 one-touch fitting (Straight)	KJH02-C1
		ø4 one-touch fitting (Straight)	KJH04-C1
		ø2 one-touch fitting (Elbow)	KJL02-C1
		ø4 one-touch fitting (Elbow)	KJL04-C1-N
		ø2 one-touch fitting (Long elbow)	KJW02-C1
		ø4 one-touch fitting (Long elbow)	KJW04-C1-N
	1(P), 3(E)	ø4 one-touch fitting (Straight)	VVQ1000-50A-C4
		ø6 one-touch fitting (Straight)	VVQ1000-50A-C6
		ø4 one-touch fitting (Elbow)	SZ3000-73-1A-L4
		ø6 one-touch fitting (Elbow)	SZ3000-73-1A-L6
		ø4 one-touch fitting (Long elbow)	SZ3000-73-2A-L4
		ø6 one-touch fitting (Long elbow)	SZ3000-73-2A-L6

One-touch Fitting (Inch Size)

No.	Port	Port size	Part no.
13	2a, 2b	ø1/8" one-touch fitting (Straight)	KJH01-C1
		ø5/32" one-touch fitting (Straight)	KJH03-C1
	1(P), 3(E)	ø5/32" one-touch fitting (Straight)	VVQ1000-50A-N3
		ø1/4" one-touch fitting (Straight)	VVQ1000-50A-N7

3 Port Solenoid Valve Series VV100/D-sub Connector Plug-in Connector Type Manifold

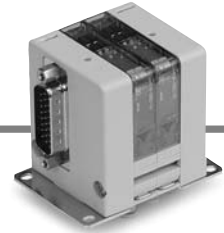

How to Order Manifold

VV100-10F **A** **D** **2** - **05** **U** **1** - **C6**

D-sub connector type

Symbol	Number of poles
A	15
B	26

Connector block
mounting position: D side

Connector entry direction

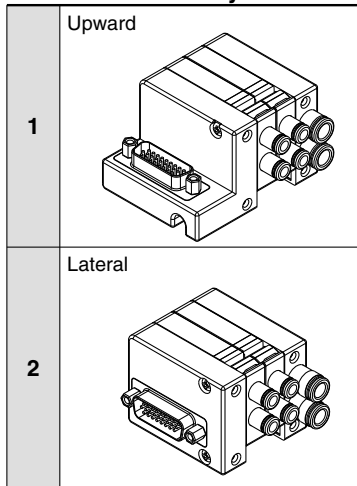

Valve stations

A: D-sub connector 15 pins

Symbol	Stations	Note
01	1 station	Up to 14 solenoids possible.
⋮	⋮	
12	12 stations	

B: D-sub connector 26 pins

Symbol	Stations	Note
01	1 station	Up to 24 solenoids possible.
⋮	⋮	
12	12 stations	

SUP/EXH block
mounting position: U side

Mounting option

Symbol	Mounting
Nil	Manifold direct mounting type With mounting nut M3 x 0.5
Note) N	Manifold direct mounting type With mounting nut No. 10-32 UNF (Inch size)
F1	With bracket (Standard)
F2	With bracket (Port downward)

Note) If the mounting option "N" (Mounting nut: Inch size) is selected, the bracket cannot be mounted.

SUP/EXH block port size

One-touch fitting (Metric size)

C4	ø4 one-touch fitting (Straight)
C6	ø6 one-touch fitting (Straight)
L4	ø4 elbow fitting (Upward entry)
L6	ø6 elbow fitting (Upward entry)
B4	ø4 elbow fitting (Downward entry)
B6	ø6 elbow fitting (Downward entry)

One-touch fitting (Inch size)

N3	ø5/32" one-touch fitting (Straight)
N7	ø1/4" one-touch fitting (Straight)

SUP/EXH block fitting entry direction

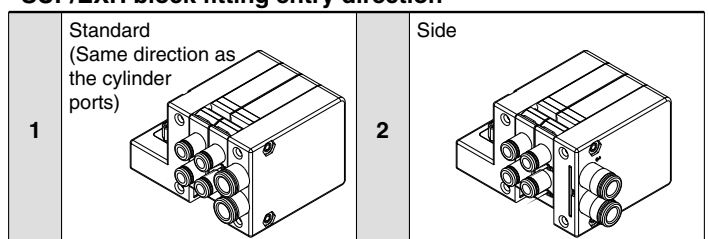

* If the mounted valve is N.O., apply pressure to the 3(E) port and exhaust air from the 1(P) port.

How to Order Valve Manifold Assembly

Ordering example (VV100-10FA)

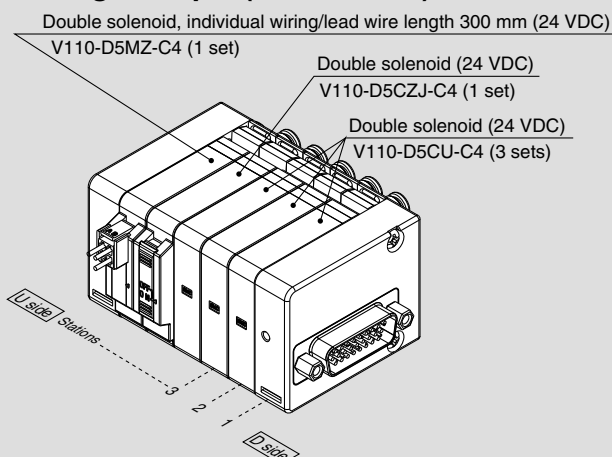

VV100-10FAD2-05U1-C6... 1 set (Manifold part no.)
 * V110-D5CU-C4 3 sets (Double solenoid part no.)
 * V110-D5CZJ-C4 1 set (Double solenoid, with switch part no.)
 * V110-D5MZ-C4 1 set (Double solenoid, individual wiring/lead wire length 300 mm part no.)

↳ The asterisk denotes the symbol for assembly.
Prefix to the part no. of the solenoid valve, etc.

- The valve arrangement is numbered as the 1st station from D side.
- Indicate the valves to be attached below the manifold part number, in order starting from station 1 as shown in the drawing.

How to Order Valve for Connector Type

Standard

V1 1 0 T - D 5 C U - C4 - □

With switch

V1 1 0 - D 5 C Z J - C4 - □

Individual wiring
[For plug-in mixed mounting] Note 1)

V1 1 0 T - D 5 M Z - C4

Note 1) See page 13 for the dedicated non plug-in individual wiring.

Type of actuation

1	Normally closed (N.C.)
2	Normally open (N.O.)

* Normally closed and normally open type cannot be mounted on the same manifold.

Coil specification

Nil	Standard
T	With power saving circuit (Continuous duty type)

* Be certain to select "with power saving circuit" when the solenoid valve will be energized continuously for long periods of time.

Number of solenoids

Symbol	Specifications
S	1 pc. (Single solenoid)
D	2 pcs. (Double solenoid)

Rated voltage

5	24 VDC
6	12 VDC

Single solenoid wiring specification

Nil	Single wiring
D	Double wiring

* Nil for the double solenoid. Select this when the unused numbers to wiring are set. See page 6 for details.

2a/2b fitting port size

Straight fitting
(Metric size)

C2: ø2 one-touch fitting

C4: ø4 one-touch fitting

(Inch size)

N1: ø1/8" one-touch fitting

N3: ø5/32" one-touch fitting

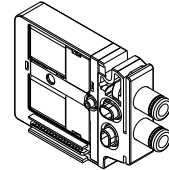

Elbow fitting (Upward entry)
(Metric size)

L2: ø2 one-touch fitting

L4: ø4 one-touch fitting

(Inch size)

LN1: ø1/8" one-touch fitting

LN3: ø5/32" one-touch fitting

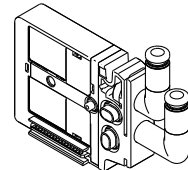

Elbow fitting (Downward entry)
(Metric size)

B2: ø2 one-touch fitting

B4: ø4 one-touch fitting

(Inch size)

BN1: ø1/8" one-touch fitting

BN3: ø5/32" one-touch fitting

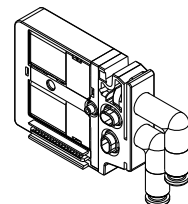

Connector entry

C: Dedicated for centralized wiring

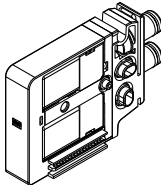

M: Individual wiring, With lead wire
Length 300 mm

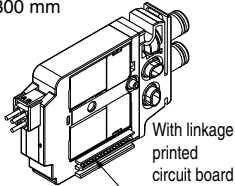

MN: Individual wiring, Without lead wire
(With connector, socket)

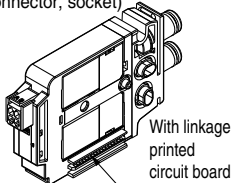

MO: Individual wiring, Without connector

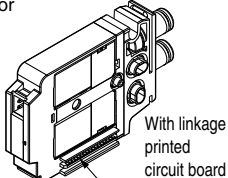

Light/surge voltage suppressor

U With light/surge voltage suppressor (Non-polar type)

Z With light/surge voltage suppressor (Polar type)

* When the types with power saving circuit, with switches, and individual wiring are used, the non-polar type cannot be selected.

* "Z" is positive common specification.

With switch

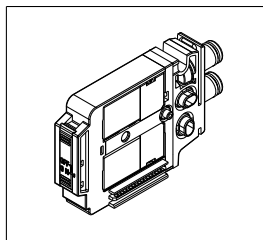

* Connector entries with the symbol "M□" cannot use the switch signal from the D-sub connector on the manifold. For details, refer to Manifold Electrical Wiring on page 6.

* When ordering a connector assembly separately, see back pages 6 and 7.



Note 2) The electric connection to the manifold will be positive common specification when light/surge voltage suppressor is "Z" (Polar type).

Series VV100

Manifold Electrical Wiring (Image)

When a valve is added, the signals of the connector are assigned to the valve. This makes it completely unnecessary to disassemble the connector unit.

* The connector arrangement shown below differs from the actual arrangement. Refer to the Connector Wiring Diagram below.

Single Solenoid and Double Solenoid

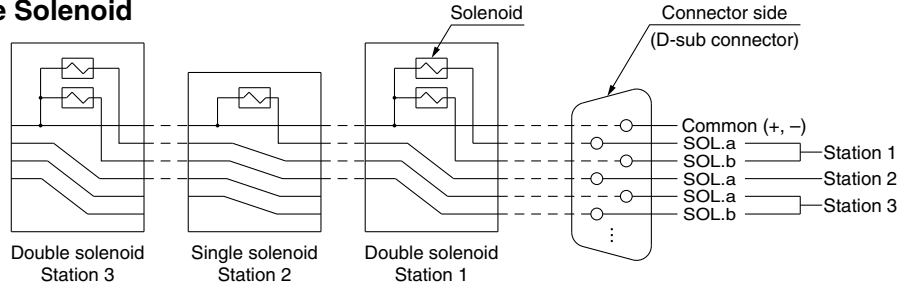

Single Solenoid with Double Wiring Specification

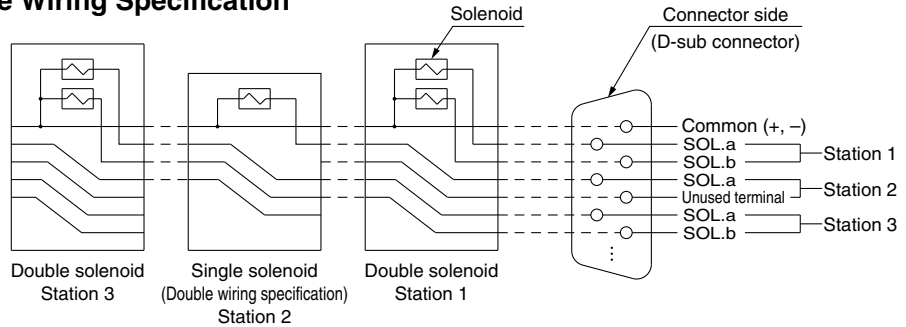

Individually Wired Valve

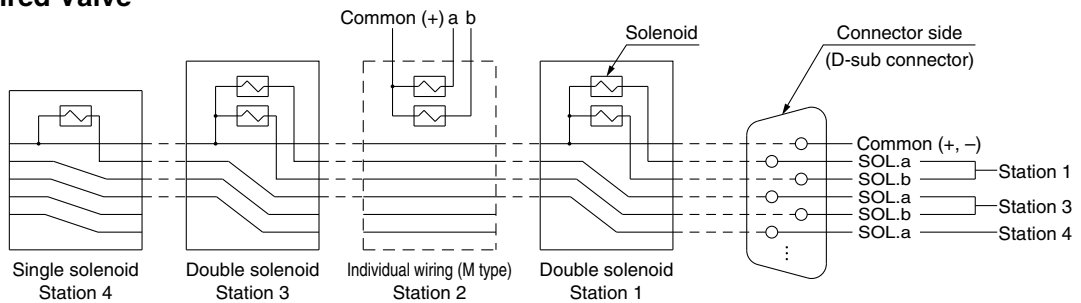

Connector Wiring Diagram

Type FA: D-sub connector (15 pins)

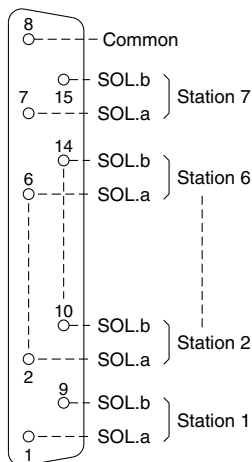

Note) This circuit is for the specification with up to 7 stations of double solenoid valves. This should be wired in order 1→9→2→10 without skipping or leaving any connectors remaining.

Type FB: D-sub connector (26 pins)

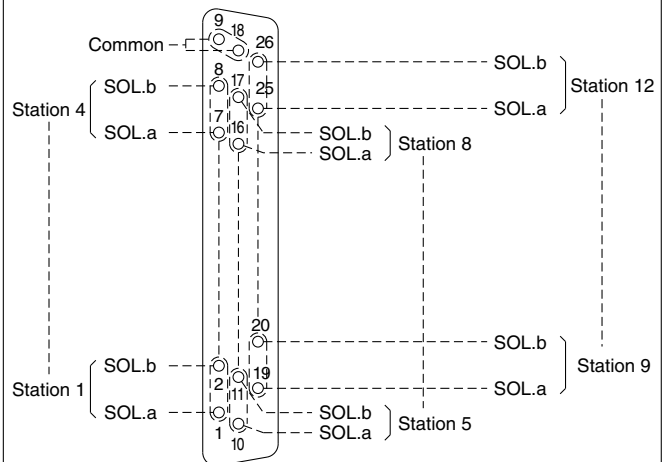

Note) This circuit is for the specification with up to 12 stations of double solenoid valves. This should be wired in order 1→2→3→4 with the exception of 9, 18 (Common) without skipping or leaving any connectors remaining.

Caution

When the non-polar type (U) valves are used, either +COM or -COM wiring of the manifold is possible. However, the valve does not switch with -COM if a type (Z) is used. Be certain to use +COM.

3 Port Solenoid Valve/D-sub Connector Plug-in Connector Type Manifold **Series VV100**

Dimensions

VV100-10F_B^AD1- [Stations] U₂-□□

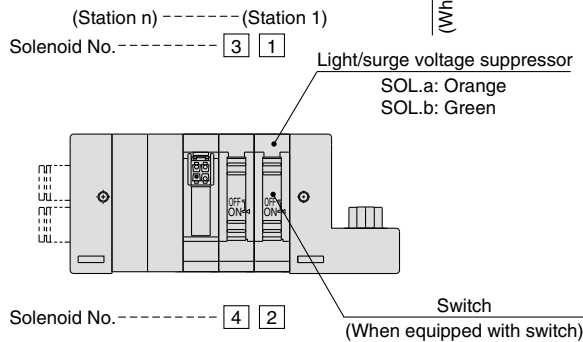
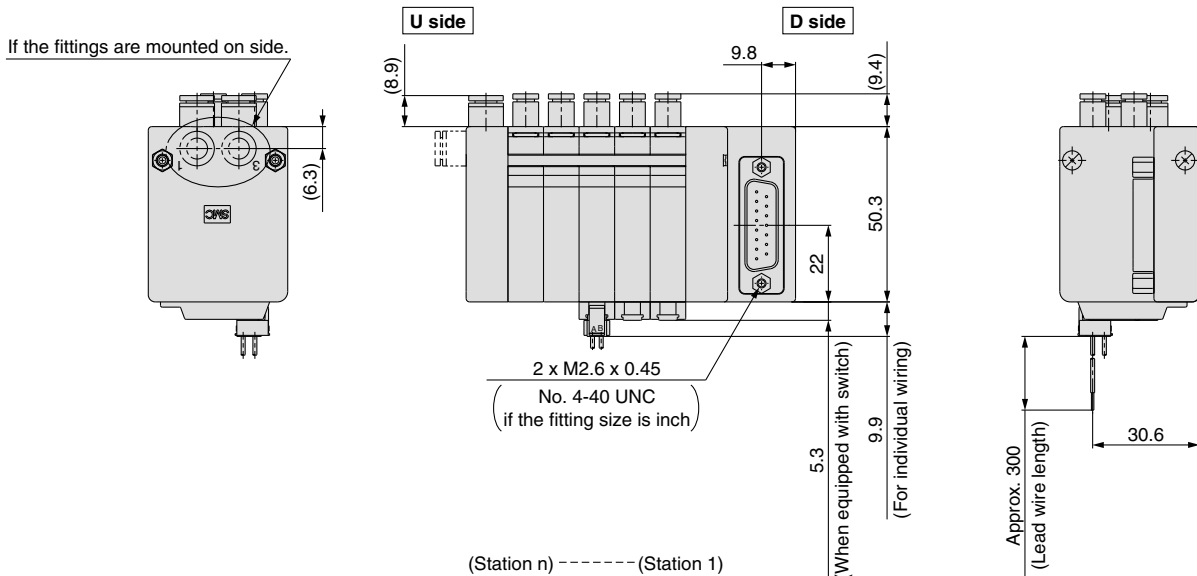
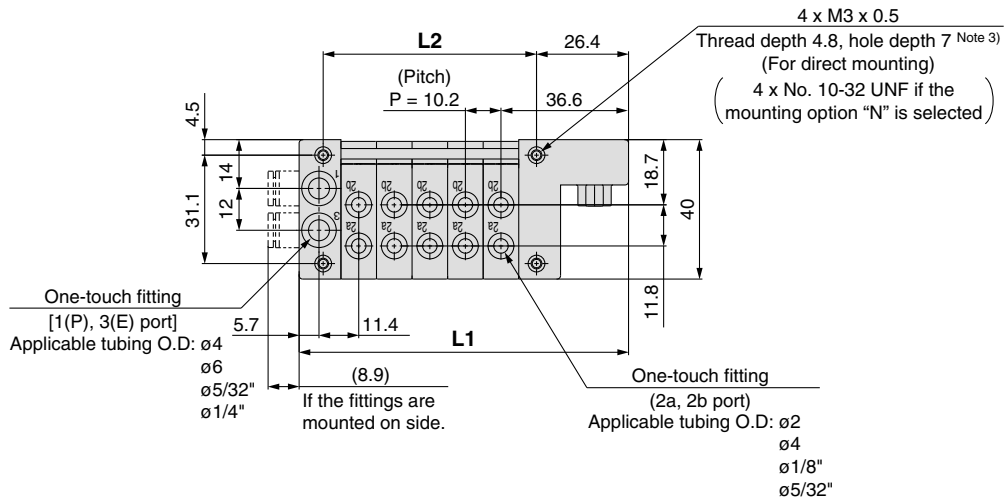

- Note 1) 10FA and 10FB types have the same L1 and L2 dimensions, and the only difference is the number of poles of the connector. See page 6 for the pin arrangement.
- Note 2) For manifold dimensions including elbow fitting, see page 11.
- Note 3) As the distance between the block end to the thread is 2.5 mm, the screw depth should be 5 to 7 mm.

L: Dimensions

L	n: Stations											
	1	2	3	4	5	6	7	8	9	10	11	12
L1	53.7	63.9	74.1	84.3	94.5	104.7	114.9	125.1	135.3	145.5	155.7	165.9
L2	20.4	30.6	40.8	51	61.2	71.4	81.6	91.8	102	112.2	122.4	132.6

Series VV100

Dimensions

VV100-10F_B^AD1- [Stations] U₂-□□ F₁¹

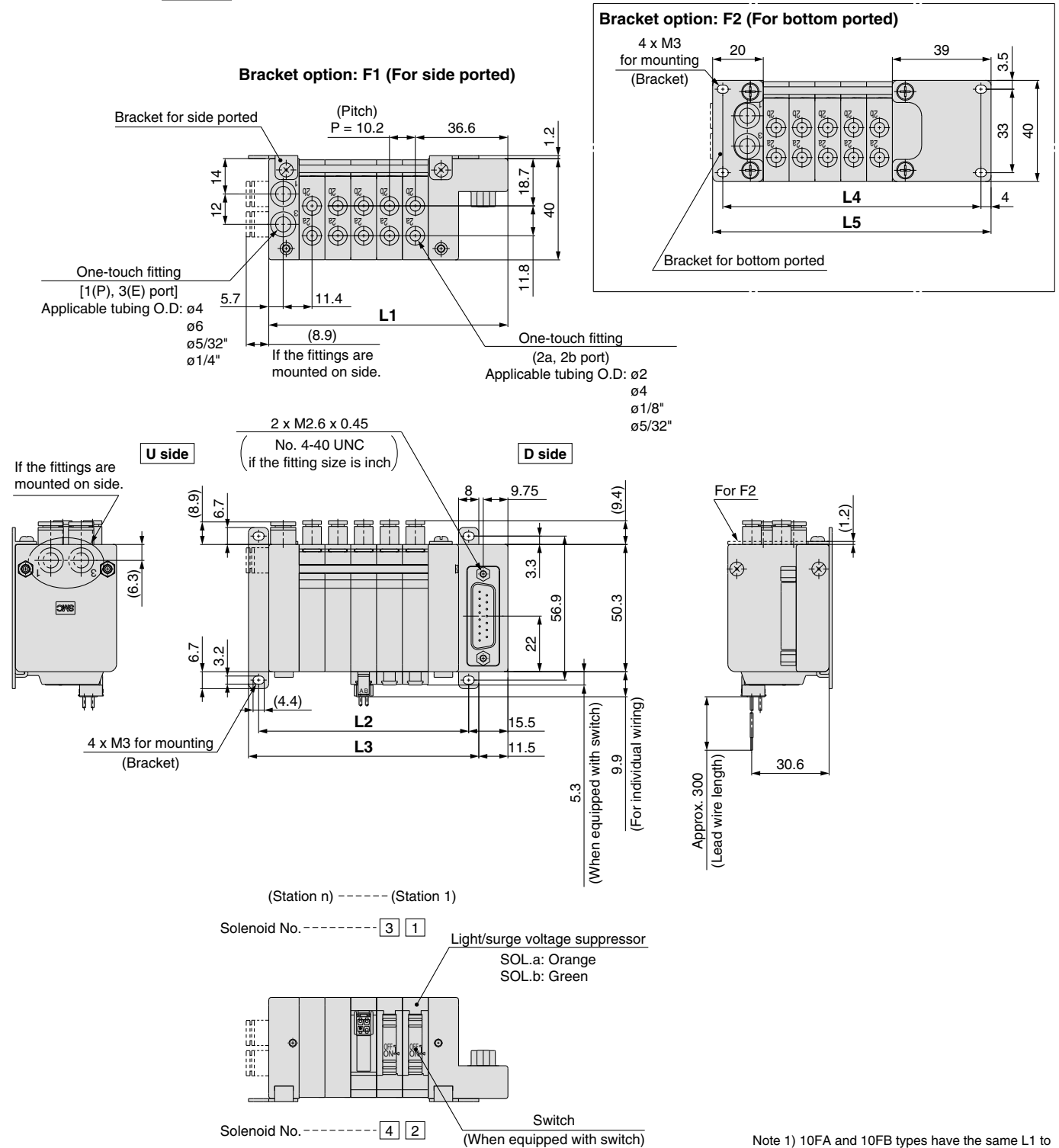

Note 1) 10FA and 10FB types have the same L1 to L5 dimensions, and the only difference is the number of poles of the connector. See page 6 for the pin arrangement.

Note 2) For manifold dimensions including elbow fitting, see page 11.

L: Dimensions

n: Stations

L \ n	1	2	3	4	5	6	7	8	9	10	11	12
L1	53.7	63.9	74.1	84.3	94.5	104.7	114.9	125.1	135.3	145.5	155.7	165.9
L2	42.2	52.4	62.6	72.8	83	93.2	103.4	113.6	123.8	134	144.2	154.4
L3	50.2	60.4	70.6	80.8	91	101.2	111.4	121.6	131.8	142	152.2	162.4
L4	61.2	71.4	81.6	91.8	102	112.2	122.4	132.6	142.8	153	163.2	173.4
L5	68.6	78.8	89	99.2	109.4	119.6	129.8	140	150.2	160.4	170.6	180.8

3 Port Solenoid Valve/D-sub Connector Plug-in Connector Type Manifold **Series VV100**

VV100-10F_BA₂D2- Stations U₂-□□

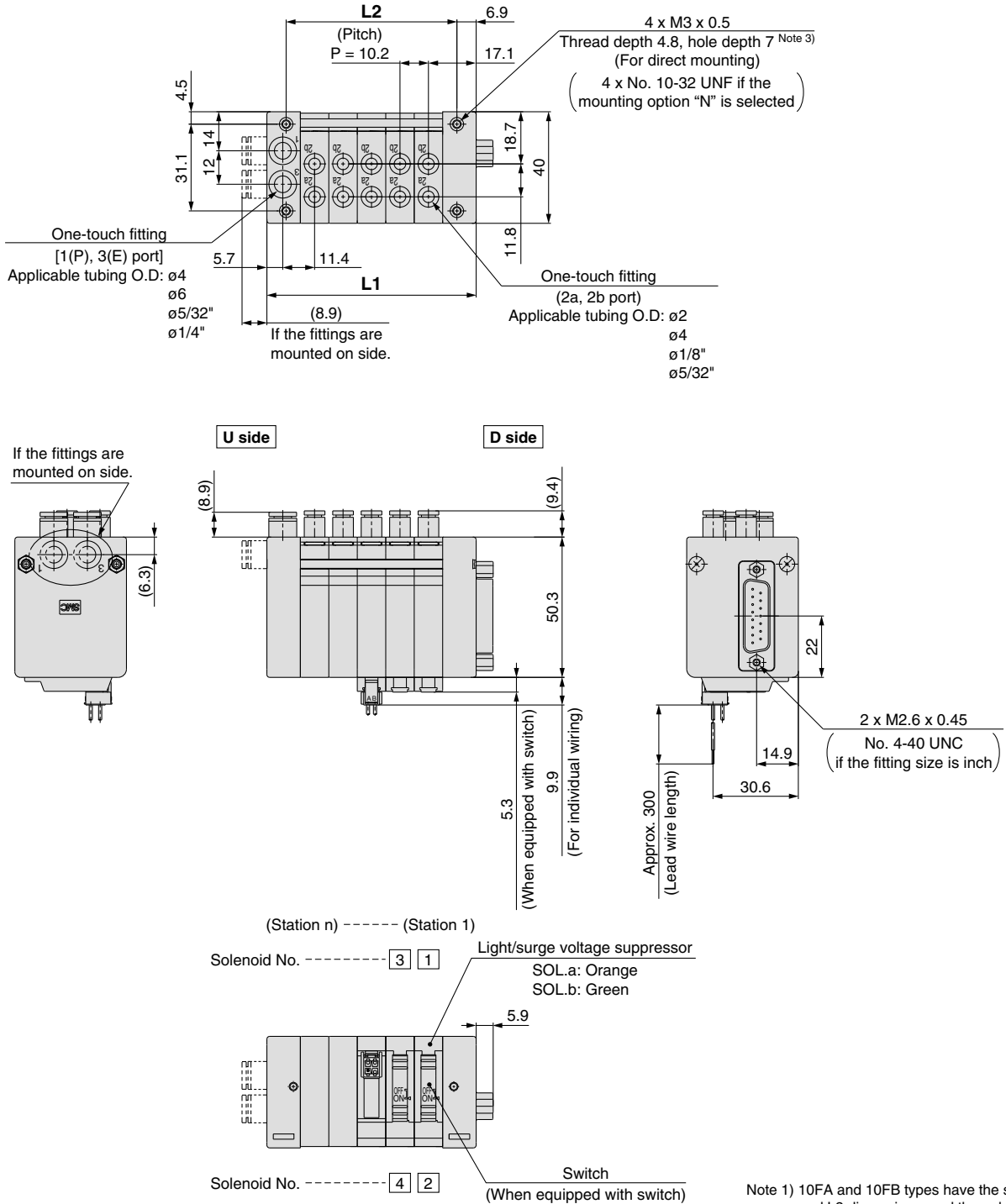

- Note 1) 10FA and 10FB types have the same L1 and L2 dimensions, and the only difference is the number of poles of the connector. See page 6 for the pin arrangement.
- Note 2) For manifold dimensions including elbow fitting, see page 11.
- Note 3) As the distance between the block end to the thread is 2.5 mm, the screw depth should be 5 to 7 mm.

L: Dimensions

L \ n	n: Stations											
	1	2	3	4	5	6	7	8	9	10	11	12
L1	34.2	44.4	54.6	64.8	75	85.2	95.4	105.6	115.8	126	136.2	146.4
L2	20.4	30.6	40.8	51	61.2	71.4	81.6	91.8	102	112.2	122.4	132.6

Series VV100

Dimensions

VV100-10F_B^AD2- [Stations] U₂-□□ F₁¹

Bracket option: F1 (For side ported)

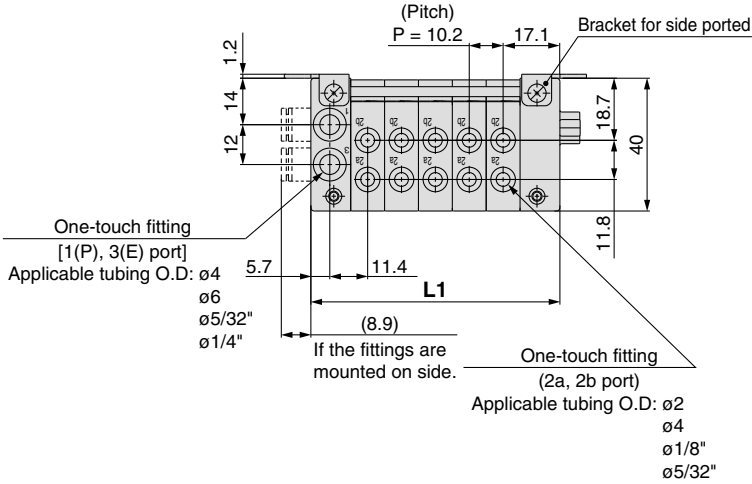

Bracket option: F2 (For bottom ported)

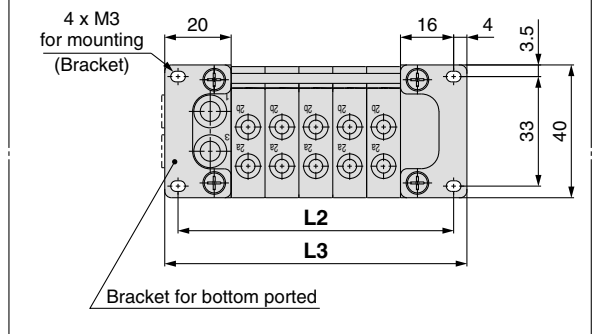

If the fittings are mounted on side.

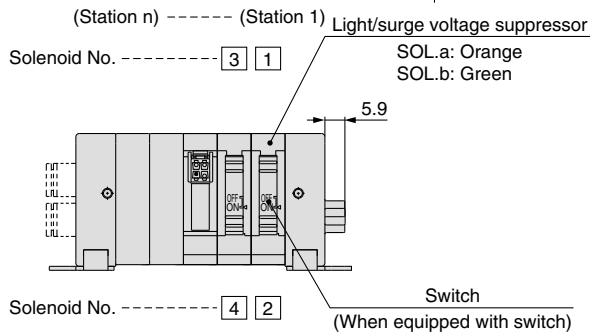
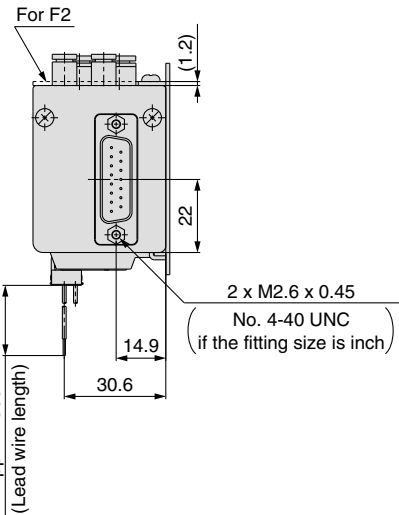
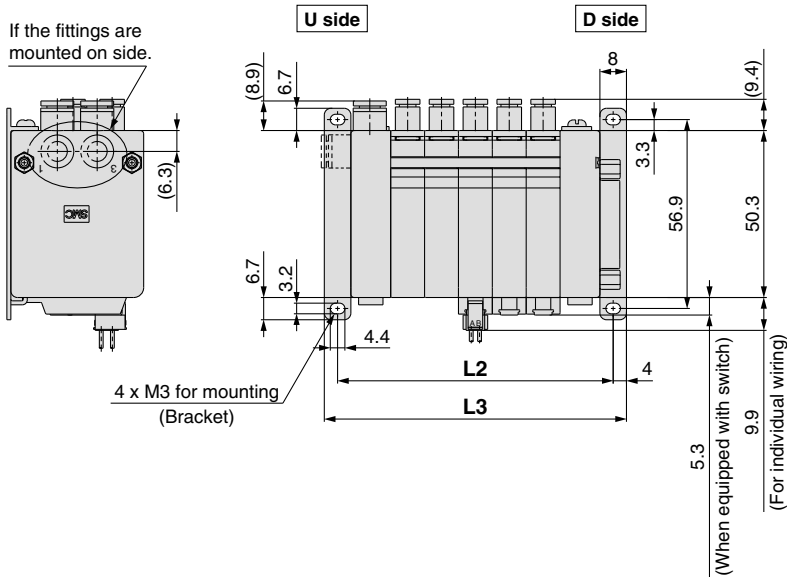

Note 1) 10FA and 10FB types have the same L1 to L3 dimensions, and the only difference is the number of poles of the connector. See page 6 for the pin arrangement.

Note 2) For manifold dimensions including elbow fitting, see page 11.

L: Dimensions

n: Stations

L \ n	1	2	3	4	5	6	7	8	9	10	11	12
L1	34.2	44.4	54.6	64.8	75	85.2	95.4	105.6	115.8	126	136.2	146.4
L2	42.2	52.4	62.6	72.8	83	93.2	103.4	113.6	123.8	134	144.2	154.4
L3	50.2	60.4	70.6	80.8	91	101.2	111.4	121.6	131.8	142	152.2	162.4

3 Port Solenoid Valve/D-sub Connector Plug-in Connector Type Manifold **Series VV100**

VV100-10FAD2- Stations U_2^1-L B

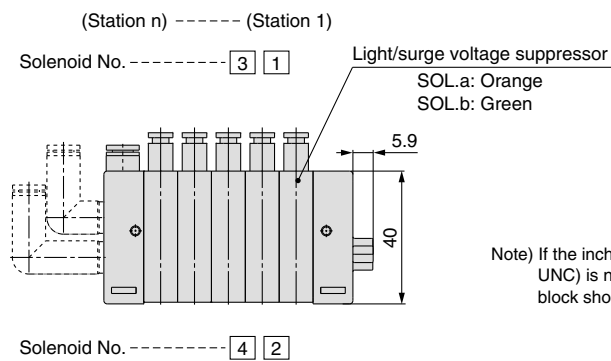
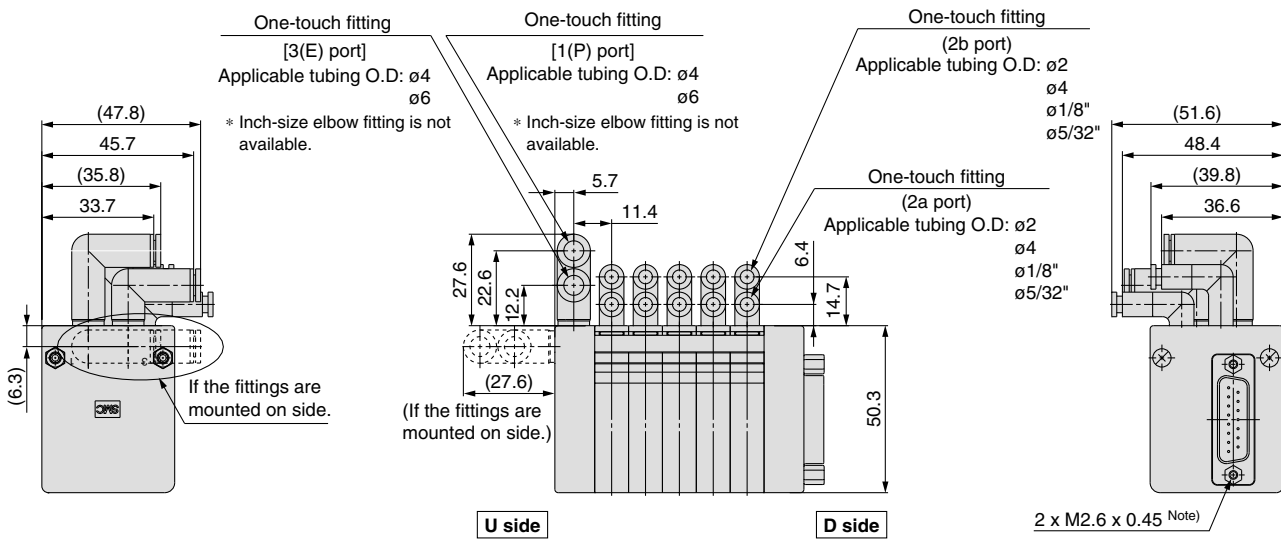
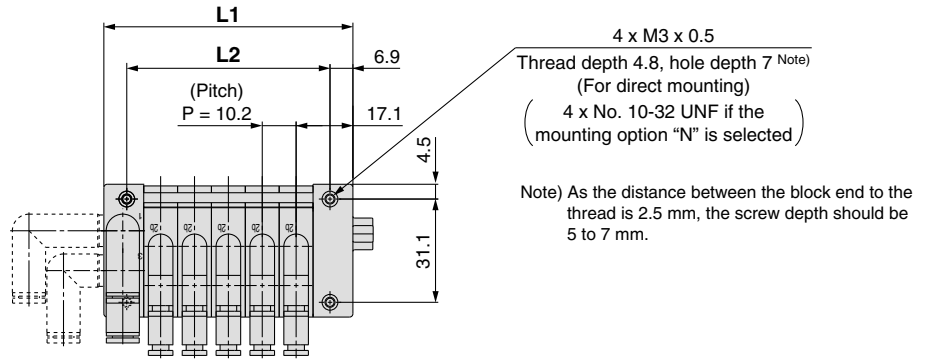

Note) If the inch-size lock bracket screw (No. 4-40 UNC) is needed, the port size of air SUP/EXH block should also be inch size (straight only).

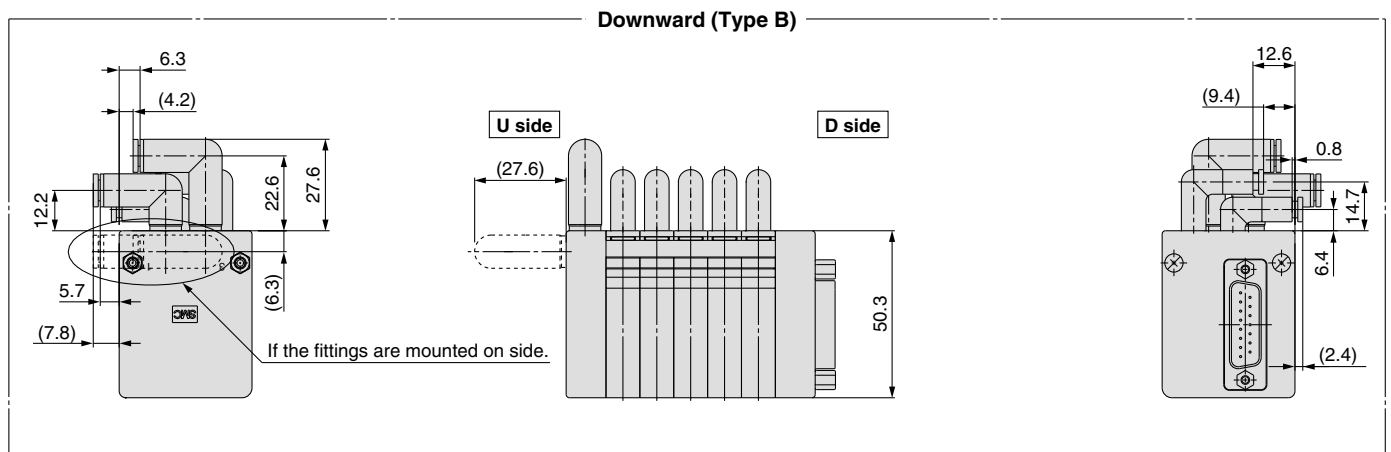

3 Port Solenoid Valve Series VV100

Non Plug-in Individual Wiring Manifold



How to Order Manifold

VV100-10-05U1-C6

Valve stations

Symbol	Stations
01	1 station
⋮	⋮
12	12 stations

SUP/EXH block
mounting position: U side

SUP/EXH block fitting entry direction

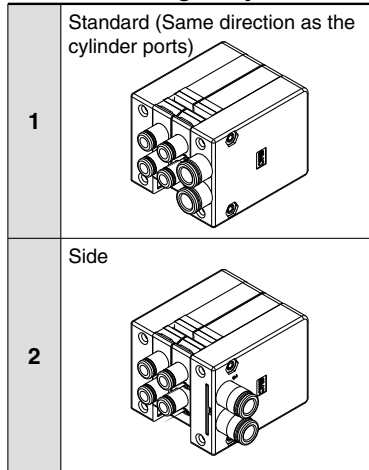

Note) If the mounted valve is N.O., apply pressure to the 3(E) port and exhaust air from the 1(P) port.

Mounting option

Symbol	Mounting
Nil	Manifold direct mounting type
N (Note)	Manifold direct mounting type
F1	With bracket (Standard)
F2	With bracket (Port downward)

Note) If the mounting option "N" (Mounting nut: Inch size) is selected, the bracket cannot be mounted.

How to Order Valve Manifold Assembly

Ordering example (VV100-10-□)

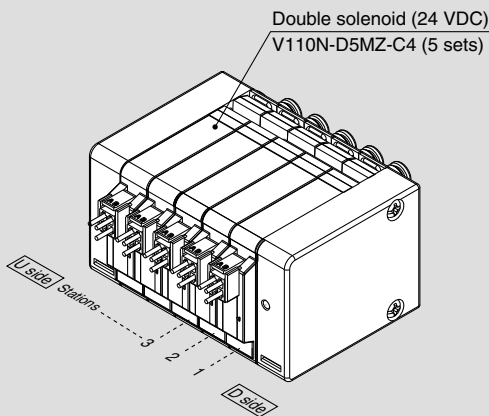

VV100-10-05U1-C6 1 set (Manifold part no.)
 * V110N-D5MZ-C4 5 sets (Double solenoid part no.)
 The asterisk denotes the symbol for assembly.
 Prefix to the part no. of the solenoid valve, etc.

- The valve arrangement is numbered as the 1st station from D side.
- Indicate the valves to be attached below the manifold part number, in order starting from station 1 as shown in the drawing.

SUP/EXH block port size

One-touch fitting (Metric size)

C4	ø4 one-touch fitting (Straight)
C6	ø6 one-touch fitting (Straight)
L4	ø4 elbow fitting (Upward entry)
L6	ø6 elbow fitting (Upward entry)
B4	ø4 elbow fitting (Downward entry)
B6	ø6 elbow fitting (Downward entry)

One-touch fitting (Inch size)

N3	ø5/32" one-touch fitting (Straight)
N7	ø1/4" one-touch fitting (Straight)

How to Order Valve Dedicated for Non Plug-in Individual Wiring

V110TN-D5MZ-C4

Type of actuation

1	Normally closed (N.C.)
2	Normally open (N.O.)

* Normally closed and normally open type cannot be mounted on the same manifold.

Coil specification

Nil	Standard
T	With power saving circuit (Continuous duty type)

* Be certain to select "with power saving circuit" when the solenoid valve will be energized continuously for long periods of time.

Non plug-in

Number of solenoids

Symbol	Specifications
S	1 pc. (Single solenoid)
D	2 pcs. (Double solenoid)

Rated voltage

5	24 VDC
6	12 VDC

Connector entry

M: Individual wiring, With lead wire
Length 300 mm

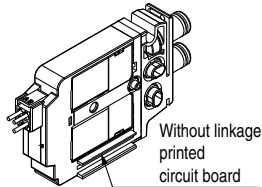

MN: Individual wiring, Without lead wire
(With connector, socket)

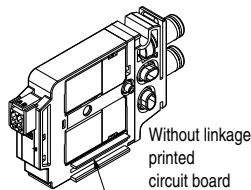

MO: Individual wiring, Without connector

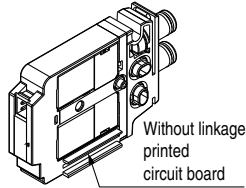

* When ordering a connector assembly separately, see back pages 6 and 7.

2a/2b fitting port size

Straight fitting
(Metric size)

C2: ø2 one-touch fitting

C4: ø4 one-touch fitting
(Inch size)

N1: ø1/8" one-touch fitting

N3: ø5/32" one-touch fitting

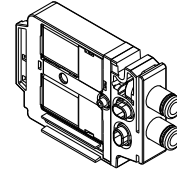

Elbow fitting (Upward entry)
(Metric size)

L2: ø2 one-touch fitting

L4: ø4 one-touch fitting
(Inch size)

LN1: ø1/8" one-touch fitting

LN3: ø5/32" one-touch fitting

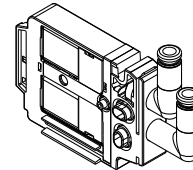

Elbow fitting (Downward entry)
(Metric size)

B2: ø2 one-touch fitting

B4: ø4 one-touch fitting
(Inch size)

BN1: ø1/8" one-touch fitting

BN3: ø5/32" one-touch fitting

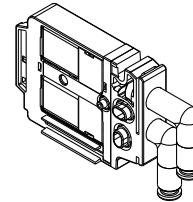

Light/surge voltage suppressor

Z With light/surge voltage suppressor

Note) Electric connection is positive common specification.

Series VV100

Dimensions

VV100-10-**Stations** U₂¹-□□

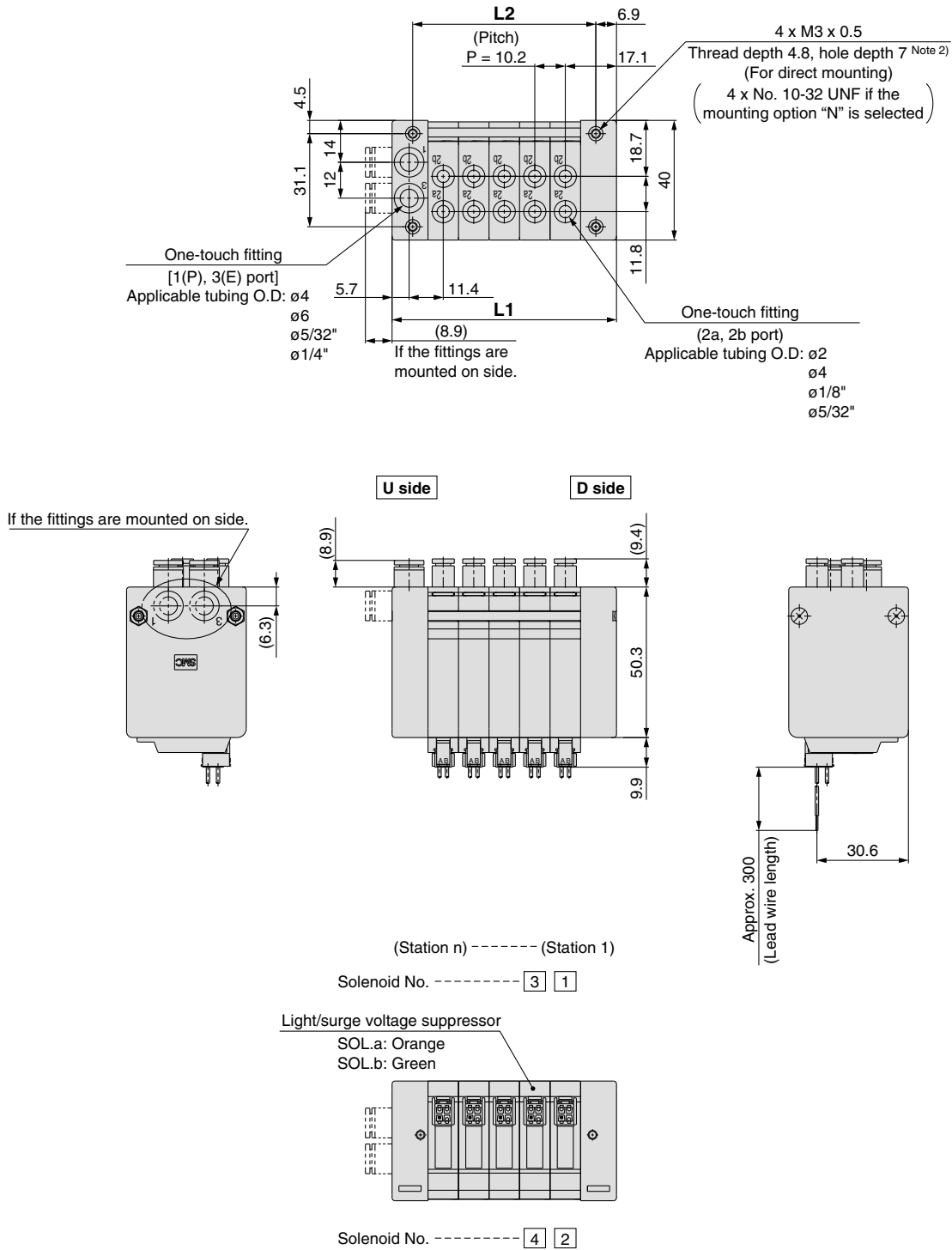

Note 1) For manifold dimensions including elbow fitting, see page 11.

Note 2) As the distance between the block end to the thread is 2.5 mm, the screw depth should be 5 to 7 mm.

L: Dimensions

n: Stations

L \ n	1	2	3	4	5	6	7	8	9	10	11	12
L1	34.2	44.4	54.6	64.8	75	85.2	95.4	105.6	115.8	126	136.2	146.4
L2	20.4	30.6	40.8	51	61.2	71.4	81.6	91.8	102	112.2	122.4	132.6

3 Port Solenoid Valve Non Plug-in Individual Wiring Manifold *Series VV100*

VV100-10-**Stations** U₂-□□F₂

Bracket option: F1 (For side ported)

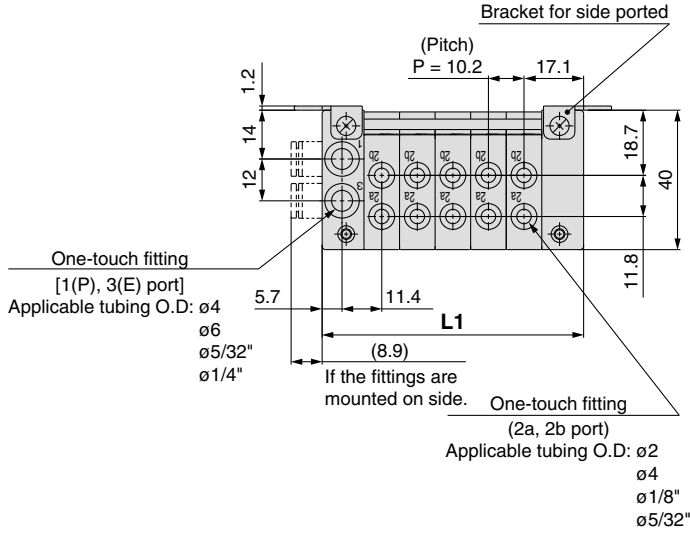

Bracket option: F2 (For bottom ported)

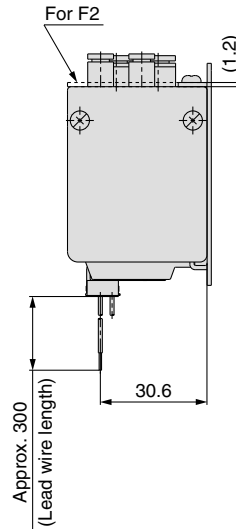
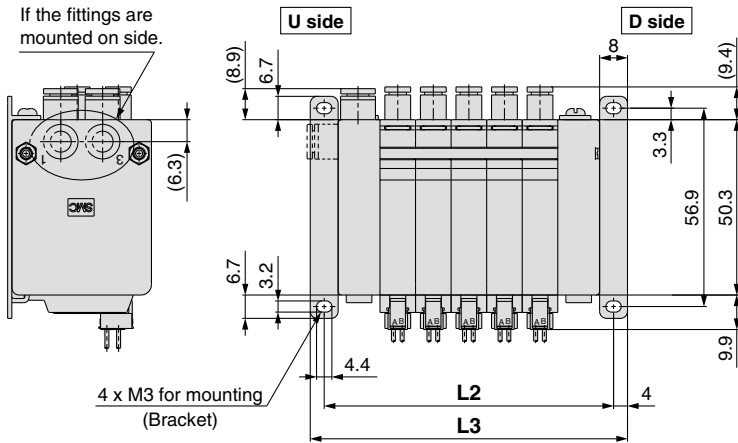
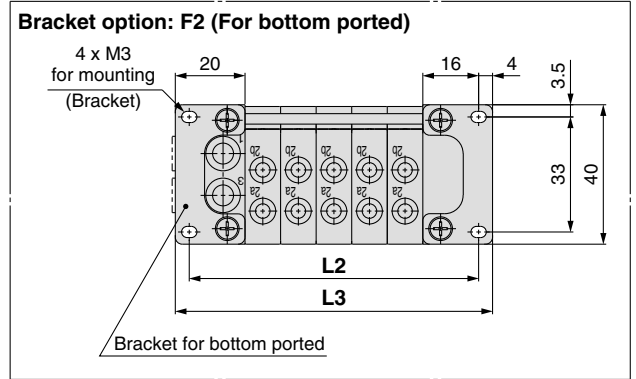

(Station n) ----- (Station 1)

Solenoid No. ----- 3 1

Light/surge voltage suppressor

SOL.a: Orange
SOL.b: Green

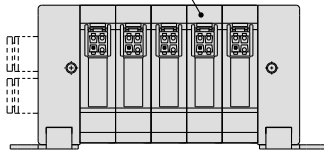

Solenoid No. ----- 4 2

Note) For manifold dimensions including elbow fitting, see page 11.

L: Dimensions

n: Stations

L \ n	1	2	3	4	5	6	7	8	9	10	11	12
L1	34.2	44.4	54.6	64.8	75	85.2	95.4	105.6	115.8	126	136.2	146.4
L2	42.2	52.4	62.6	72.8	83	93.2	103.4	113.6	123.8	134	144.2	154.4
L3	50.2	60.4	70.6	80.8	91	101.2	111.4	121.6	131.8	142	152.2	162.4

Series VV100

Manifold Exploded View

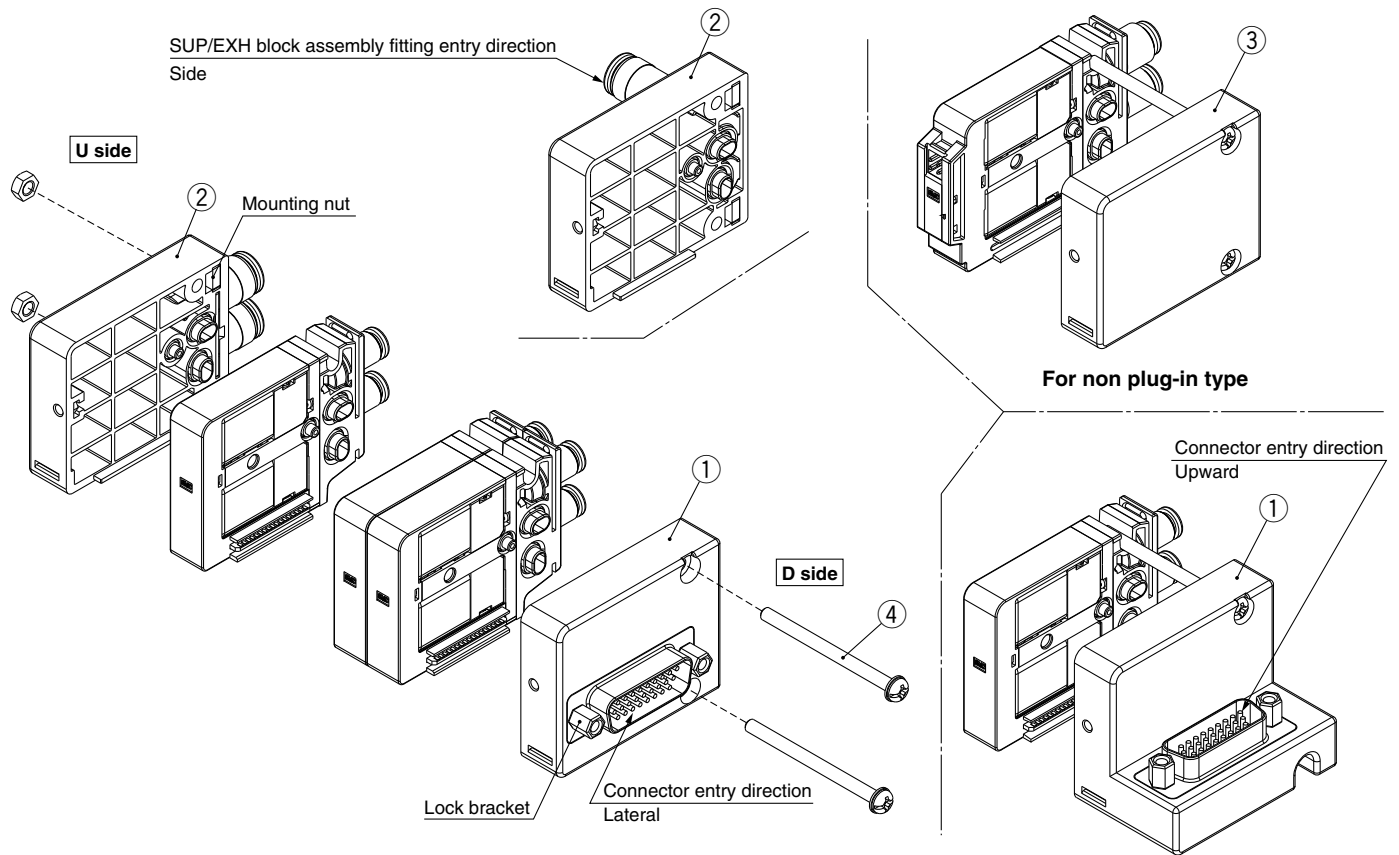

No.	Description	Part no.	Note
①	Connector block assembly ^{Note)} (For plug-in)	V100-192-□A□-15	Refer to Connector Block Assembly Part No. table below.
②	SUP/EXH end block assembly ^{Note)} (Common for plug-in and non plug-in types) <Fitting entry direction: Standard>	V100-193-1A-□ [Mounting nut (Metric size: M3)]	(Metric size) C4: ø4 one-touch fitting C6: ø6 one-touch fitting L4: ø4 elbow fitting (Upward entry) L6: ø6 elbow fitting (Upward entry) B4: ø4 elbow fitting (Downward entry) B6: ø6 elbow fitting (Downward entry)
		V100-193-2A-□ [Mounting nut (Inch size: No. 10-32 UNF)]	
②	SUP/EXH end block assembly ^{Note)} (Common for plug-in and non plug-in types) <Fitting entry direction: Side>	V100-193-3A-□ [Mounting nut (Metric size: M3)]	(Inch size) N3: ø5/32" one-touch fitting N7: ø1/4" one-touch fitting <Mounting nut part no. (4 pcs./set)> Metric size (M3): V100-197-1A Inch size (No. 10-32 UNF): V100-197-2A
		V100-193-4A-□ [Mounting nut (Inch size: No. 10-32 UNF)]	
③	End block assembly ^{Note)} (For non plug-in)	V100-199-1A [Mounting nut (Metric size: M3)]	
		V100-199-2A [Mounting nut (Inch size: No. 10-32 UNF)]	
④	Tension bolt (With hexagon nut)	V100-202-□A	□: Stations (1 to 12) 2 pcs./set

Note) If a bracket is intended to be mounted, select ① Connector block assembly, ② SUP/EXH end block assembly 1A or 3A, and ③ End block assembly 1A with mounting nut (Metric size: M3).

Connector Block Assembly Part No.

V100-192-□A□-□

Connector entry direction/Mounting nut thread type

Symbol	Thread type	Connector entry direction
1	Metric size (M3)	Lateral
2	Inch size (No. 10-32 UNF)	
3	Metric size (M3)	Upward
4	Inch size (No. 10-32 UNF)	

D-sub connector type

15	15 pins
26	26 pins

Lock bracket thread type

Nil	Metric size (M2.6)
U	Inch size (No. 4-40 UNC)

Manifold Options

■ Bracket Assembly

V100-198-1A (For side ported)
 <Common for upward/
 lateral connectors>

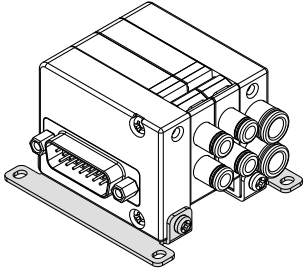

V100-198-3A (For bottom ported)
 <For lateral connector>

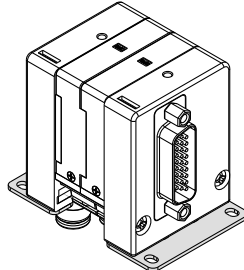

V100-198-4A (For bottom ported)
 <For upward connector>

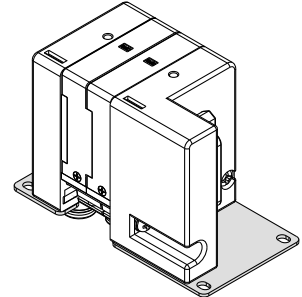

* The screws (M3) with which the bracket is mounted on the manifold are included.

■ Bracket Mounting Procedure

<For side ported>

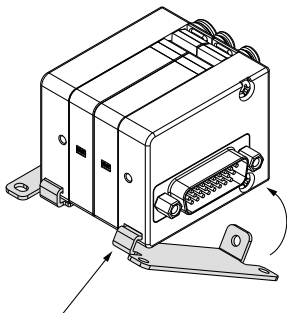

① Fit the bracket to the groove at the connector block (end block).

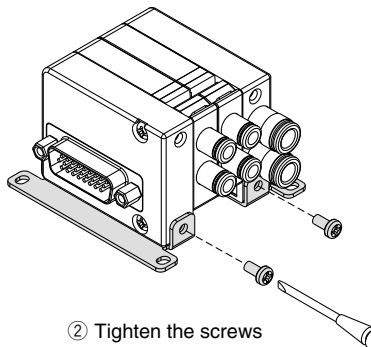

② Tighten the screws
 (Tightening torque M3:
 0.6 N·m).

<For bottom ported>

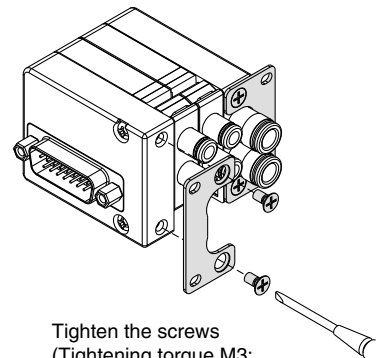

Tighten the screws
 (Tightening torque M3:
 0.6 N·m).

Note) The bracket can be mounted on the block with the mounting nut (Metric size: M3) only. It cannot be mounted on the block with inch-size mounting nut (No. 10-32 UNF).

Series VV100

Manifold Options

■ Mounting Example

Manifold direct mounting

SUP/EXH block fitting entry direction: Standard

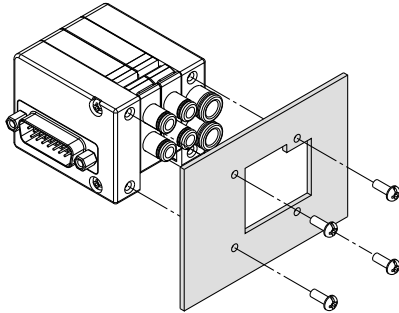

Panel fitting dimensions/Mounting hole dimensions

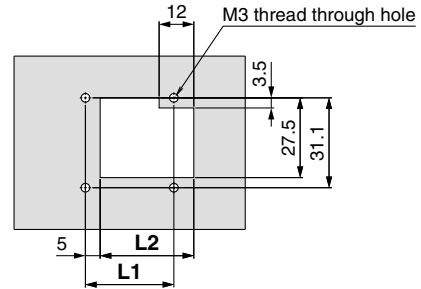

Station n	1	2	3	4	5	6	7	8	9	10	11	12
L1	20.4	30.6	40.8	51	61.2	71.4	81.6	91.8	102	112.2	122.4	132.6
L2	22.2	32.4	42.6	52.8	63	73.2	83.4	93.6	103.8	114	124.2	134.4

SUP/EXH block fitting entry direction: Side

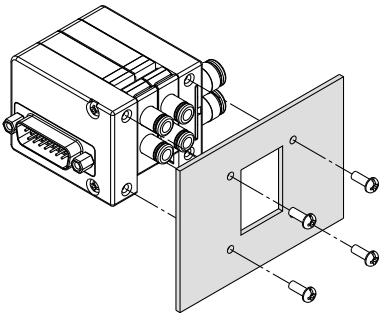

Panel fitting dimensions/Mounting hole dimensions

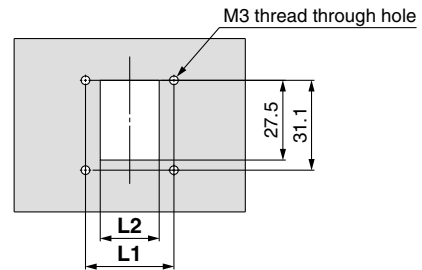

Station n	1	2	3	4	5	6	7	8	9	10	11	12
L1	20.4	30.6	40.8	51	61.2	71.4	81.6	91.8	102	112.2	122.4	132.6
L2	10.2	20.4	30.6	40.8	51	61.2	71.4	81.6	91.8	102.0	112.2	122.4

Bracket mounting (For bottom ported)

Upward connector

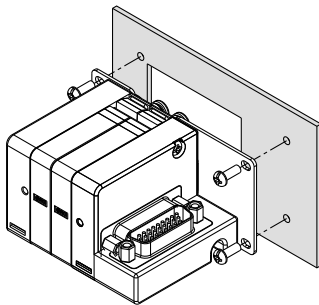

Panel fitting dimensions/Mounting hole dimensions

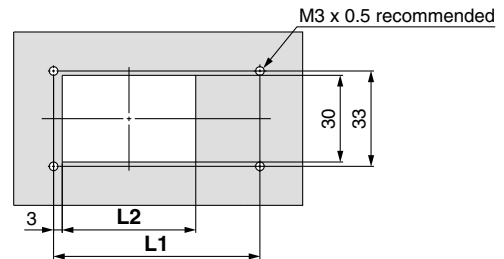

Station n	1	2	3	4	5	6	7	8	9	10	11	12
L1	61.2	71.4	81.6	91.8	102	112.2	122.4	132.6	142.8	153	163.2	173.4
L2	36	46.2	56.4	66.6	76.8	87	97.2	107.4	117.6	127.8	138	148.2

Lateral connector

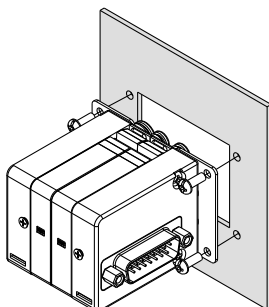

Panel fitting dimensions/Mounting hole dimensions

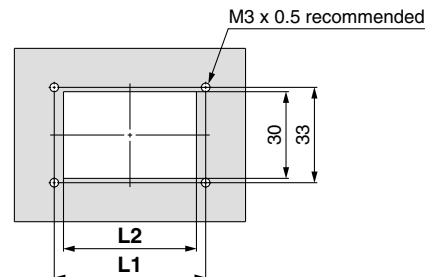

Station n	1	2	3	4	5	6	7	8	9	10	11	12
L1	52.4	62.6	72.8	83	93.2	103.4	113.6	123.8	134	144.2	154.4	164.6
L2	36	46.2	56.4	66.6	76.8	87	97.2	107.4	117.6	127.8	138	148.2

Manifold Options

D-sub connector cable assembly

For 15 pins V100-DS15-□□□ (N)

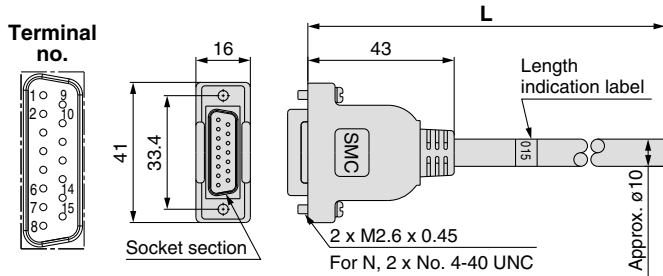

For 26 pins V100-DS26-□□□ (N)

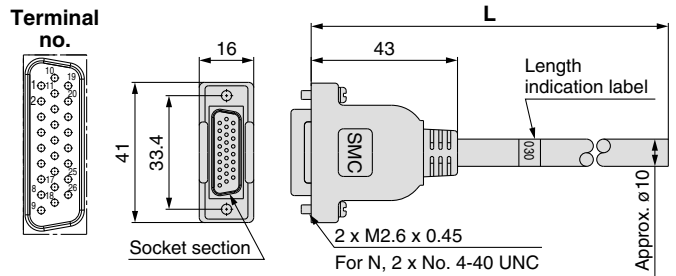

D-sub Connector Cable Assembly

Cable length L	Assembly part no.	Note
1.5 m	V100-DS15-015(N)	Cable 15 cores X23AWG
3 m	V100-DS15-030(N)	
5 m	V100-DS15-050(N)	

Note) For N, the unified thread is used.
 For other commercial connectors, use a 15 pin type with female connector conforming to MIL-C24308.

D-sub Connector Cable Assembly

Cable length L	Assembly part no.	Note
1.5 m	V100-DS26-015(N)	Cable 26 cores X23AWG
3 m	V100-DS26-030(N)	
5 m	V100-DS26-050(N)	

Note) For N, the unified thread is used.

D-sub Connector Cable Assembly Cable Color List of Each Terminal No.

Terminal no.	Lead wire color	Dot marking
1	Black	None
2	Brown	None
3	Red	None
4	Orange	None
5	Yellow	None
6	Pink	None
7	Blue	None
8	Purple	White
9	Gray	Black
10	White	Black
11	White	Red
12	Yellow	Red
13	Orange	Red
14	Yellow	Black
15	Pink	Black

D-sub Connector Cable Assembly Cable Color List of Each Terminal No.

Terminal no.	Lead wire color	Dot marking
1	Black	None
2	Brown	None
3	Red	None
4	Orange	None
5	Yellow	None
6	Pink	None
7	Blue	None
8	Purple	White
9	Gray	Black
10	White	Black
11	White	Red
12	Yellow	Red
13	Orange	Red
14	Yellow	Black
15	Pink	Black
16	Blue	White
17	Purple	None
18	Gray	None
19	Orange	Black
20	Red	White
21	Brown	White
22	Pink	Red
23	Gray	Red
24	Black	White
25	White	None
26	Light blue	None

Electric Characteristics

Item	Characteristics
Conductor resistance Ω/km, 20°C	65 or less
Withstand pressure V, 1 min, AC	1000
Insulation resistance MΩkm, 20°C	5 or more

* The minimum bending radius for D-sub connector cables is 20 mm.





Safety Instructions

These safety instructions are intended to prevent hazardous situations and/or equipment damage. These instructions indicate the level of potential hazard with the labels of “**Caution**,” “**Warning**” or “**Danger**.” They are all important notes for safety and must be followed in addition to International Standards (ISO/IEC), Japan Industrial Standards (JIS)*1) and other safety regulations*2).

- * 1) ISO 4414: Pneumatic fluid power – General rules relating to systems.
ISO 4413: Hydraulic fluid power – General rules relating to systems.
IEC 60204-1: Safety of machinery – Electrical equipment of machines. (Part 1: General requirements)
ISO 10218-1992: Manipulating industrial robots -Safety.
JIS B 8370: General rules for pneumatic equipment.
JIS B 8361: General rules for hydraulic equipment.
JIS B 9960-1: Safety of machinery – Electrical equipment of machines. (Part 1: General requirements)
JIS B 8433-1993: Manipulating industrial robots - Safety.
etc.
- * 2) Labor Safety and Sanitation Law, etc.

 **Caution:** Operator error could result in injury or equipment damage.

 **Warning:** Operator error could result in serious injury or loss of life.

 **Danger :** In extreme conditions, there is a possibility of serious injury or loss of life.

Warning

1. The compatibility of the product is the responsibility of the person who designs the equipment or decides its specifications.

Since the product specified here is used under various operating conditions, its compatibility with specific equipment must be decided by the person who designs the equipment or decides its specifications based on necessary analysis and test results. The expected performance and safety assurance of the equipment will be the responsibility of the person who has determined its compatibility with the product. This person should also continuously review all specifications of the product referring to its latest catalog information, with a view to giving due consideration to any possibility of equipment failure when configuring the equipment.

2. Only personnel with appropriate training should operate machinery and equipment.

The product specified here may become unsafe if handled incorrectly. The assembly, operation and maintenance of machines or equipment including our products must be performed by an operator who is appropriately trained and experienced.

3. Do not service or attempt to remove product and machinery/equipment until safety is confirmed.

1. The inspection and maintenance of machinery/equipment should only be performed after measures to prevent falling or runaway of the driven objects have been confirmed.

2. When the product is to be removed, confirm that the safety measures as mentioned above are implemented and the power from any appropriate source is cut, and read and understand the specific product precautions of all relevant products carefully.

3. Before machinery/equipment is restarted, take measures to prevent unexpected operation and malfunction.

4. Contact SMC beforehand and take special consideration of safety measures if the product is to be used in any of the following conditions.

1. Conditions and environments outside of the given specifications, or use outdoors or in a place exposed to direct sunlight.

2. Installation on equipment in conjunction with atomic energy, railways, air navigation, space, shipping, vehicles, military, medical treatment, combustion and recreation, or equipment in contact with food and beverages, emergency stop circuits, clutch and brake circuits in press applications, safety equipment or other applications unsuitable for the standard specifications described in the product catalog.

3. An application which could have negative effects on people, property, or animals requiring special safety analysis.

4. Use in an interlock circuit, which requires the provision of double interlock for possible failure by using a mechanical protective function, and periodical checks to confirm proper operation.



Safety Instructions

Caution

The product is provided for use in manufacturing industries.

The product herein described is basically provided for peaceful use in manufacturing industries.

If considering using the product in other industries, consult SMC beforehand and exchange specifications or a contract if necessary. If anything is unclear, contact your nearest sales branch.

Limited Warranty and Disclaimer/Compliance Requirements

The product used is subject to the following “Limited Warranty and Disclaimer” and “Compliance Requirements”. Read and accept them before using the product.

Limited Warranty and Disclaimer

1. The warranty period of the product is 1 year in service or 1.5 years after the product is delivered.*3)

Also, the product may have specified durability, running distance or replacement parts. Please consult your nearest sales branch.

2. For any failure or damage reported within the warranty period which is clearly our responsibility, a replacement product or necessary parts will be provided.

This limited warranty applies only to our product independently, and not to any other damage incurred due to the failure of the product.

3. Prior to using SMC products, please read and understand the warranty terms and disclaimers noted in the specified catalog for the particular products.

*** 3) Vacuum pads are excluded from this 1 year warranty.**

A vacuum pad is a consumable part, so it is warranted for a year after it is delivered.

Also, even within the warranty period, the wear of a product due to the use of the vacuum pad or failure due to the deterioration of rubber material are not covered by the limited warranty.

Compliance Requirements

When the product is exported, strictly follow the laws required by the Ministry of Economy, Trade and Industry (Foreign Exchange and Foreign Trade Control Law).



Series VV100

Specific Product Precautions 1

Be sure to read this before handling.

Refer to back pages 1 and 2 for Safety Instructions, "Handling Precautions for SMC Products" (M-E03-3) for 3 Port Solenoid Valve Precautions.

Valve with Switch

Warning

When turning off the valve using the switch, move it to the position where the valve is locked. If the switch is at an improper position and is energized, equipment connected to the valve could be actuated. Also, if the switch is turned OFF on the valve in the energized state, be careful because any actuators connected will actuate.

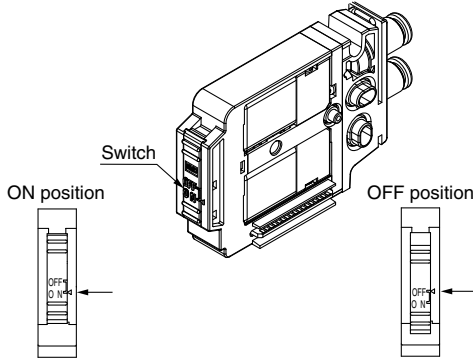

Normal operation: The valve is switched according to electric signals from the connector on the manifold side.

The valve coil is kept in a deenergized state even when there is an electric signal from the connector on the manifold side.

Electric circuit diagram (with positive common and light/surge voltage suppressor)

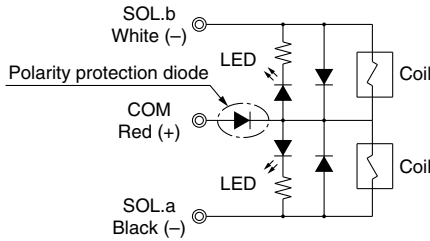

Light/Surge Voltage Suppressor

Caution

Non-Polar Type

Single solenoid

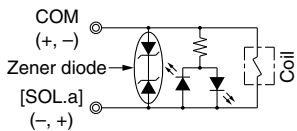

Double solenoid

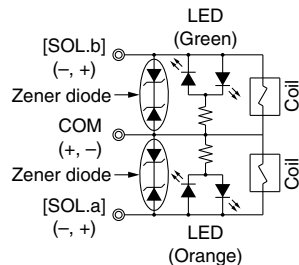

Polar Type

Single solenoid

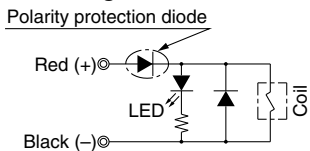

Double solenoid

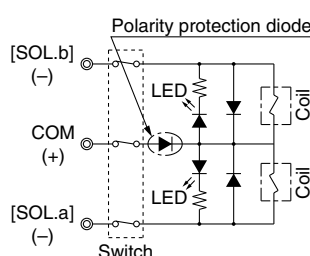

Countermeasure for Surge Voltage Intrusion

Caution

With non-polar type solenoid valves, at times of sudden interruption of the loading power supply, such as emergency shutdown, surge voltage intrusion may be generated from loading equipment with a large capacity (power consumption), and the solenoid valve in a deenergized state may switch over (see Figure 1). When installing a breaker circuit for the loading power supply, consider using a solenoid valve with polarity (with polarity protection diode), or install a surge absorption diode between the loading equipment COM line and the output equipment COM line (see Figure 2).

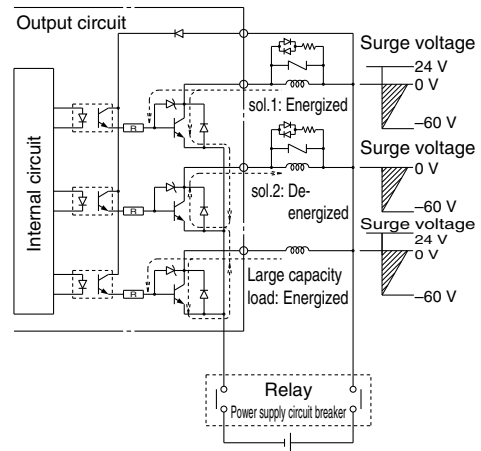

Figure 1. Surge intrusion circuit example (24 VDC)

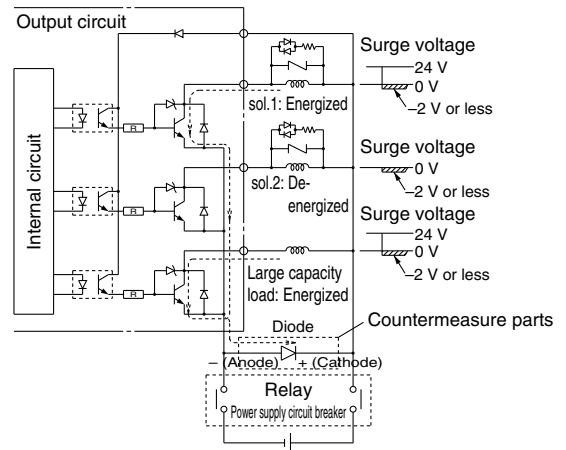

Figure 2. Surge intrusion circuit example (24 VDC)

Continuous Duty

Caution

If a valve is energized continuously for long periods of time, the rise in temperature due to heat-up of the coil may cause a decline in solenoid valve performance, reduce service life, or have adverse effects on peripheral equipment. If a valve will be energized continuously, be sure to use the "Continuous duty type" with a power saving circuit. In particular, there will be a large increase in temperature if 3 or more neighboring stations are simultaneously energized continuously for long periods of time, or if the a and b sides are simultaneously energized continuously for long periods of time. Be very careful in such cases.



Series VV100

Specific Product Precautions 2

Be sure to read this before handling.

Refer to back pages 1 and 2 for Safety Instructions, "Handling Precautions for SMC Products" (M-E03-3) for 3 Port Solenoid Valve Precautions.

Continuous Duty

Caution

With Power Saving Circuit

Compared to the standard products, power consumption is reduced down to approx. 1/3 (V1□0T) by cutting the unnecessary wattage required to hold the valve in an energized state. (Effective energizing time is over 67 ms at 24 VDC.)

Electric circuit diagram (with power saving circuit)
Single solenoid

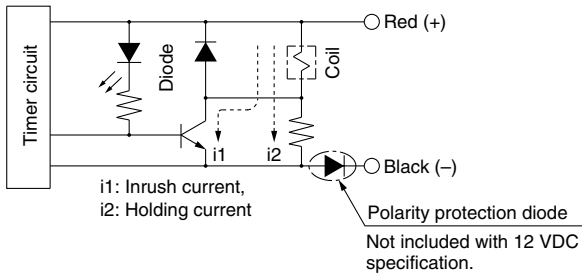

Working Principle

With the circuit above, the current consumption, when holding, is reduced to save energy. Refer to the electric wave data below.

Power waveform of power saving type (V1□0T)

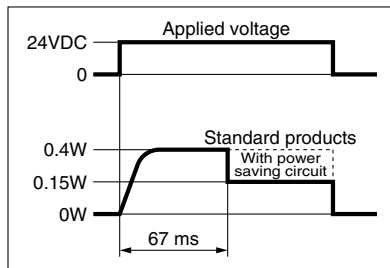

- When a power saving circuit is installed, a diode to prevent reverse current is not available for 12 V DC specification. Therefore, use caution not to connect in reverse.
- Be careful about the allowable voltage fluctuation since a voltage drop of about 0.5 V occurs due to a transistor. (Refer to the solenoid specifications of each valve for details.)

Light Indication

Caution

When equipped with light/surge voltage suppressor, the light window turns orange when solenoid a is energized, and it turns green when solenoid b is energized.

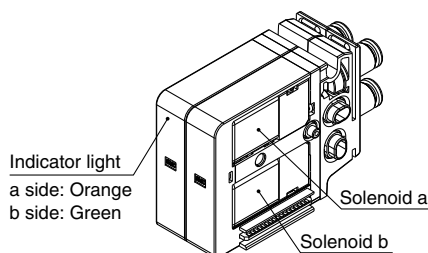

Fitting Replacement

Caution

By replacing a valve's fitting, it is possible to change the port size of the 2a, 2b, 1(P), and 3(E) ports. When replacing it, pull out the fitting after removing the clip or the plate with a flat head screwdriver, etc. To mount a new fitting, insert it into place and then fully reinsert the clip or the plate.

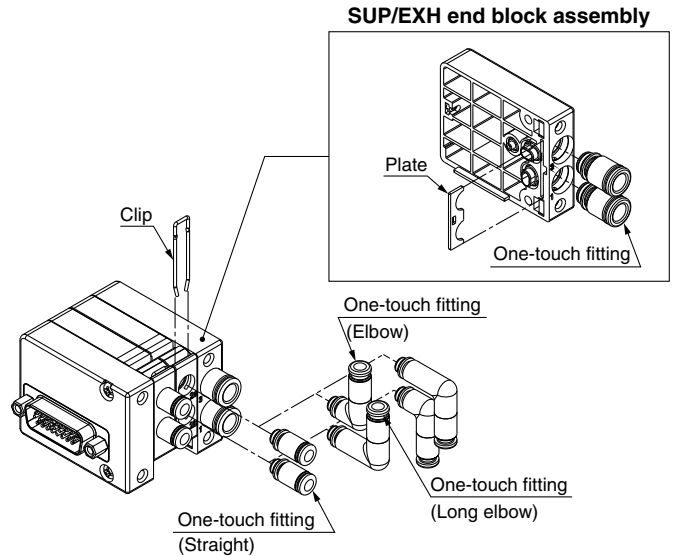

One-touch Fitting Part No.

Metric Size

Port	Port size	Part no.
2(a) 2(b)	ø2 one-touch fitting (Straight)	KJH02-C1
	ø4 one-touch fitting (Straight)	KJH04-C1
	ø2 one-touch fitting (Elbow)	KJL02-C1
	ø4 one-touch fitting (Elbow)	KJL04-C1-N
1(P) 3(E)	ø2 one-touch fitting (Long elbow)	KJW02-C1
	ø4 one-touch fitting (Long elbow)	KJW04-C1-N
	ø4 one-touch fitting (Straight)	VVQ1000-50A-C4
	ø6 one-touch fitting (Straight)	VVQ1000-50A-C6
	ø4 one-touch fitting (Elbow)	SZ3000-73-1A-L4
	ø6 one-touch fitting (Elbow)	SZ3000-73-1A-L6
1(P) 3(E)	ø4 one-touch fitting (Long elbow)	SZ3000-73-2A-L4
	ø6 one-touch fitting (Long elbow)	SZ3000-73-2A-L6

Inch Size

Port	Port size	Part no.
2(a)	ø 1/8" one-touch fitting (Straight)	KJH01-C1
2(b)	ø 5/32" one-touch fitting (Straight)	KJH03-C1
1(P)	ø 5/32" one-touch fitting (Straight)	VVQ1000-50A-N3
3(E)	ø 1/4" one-touch fitting (Straight)	VVQ1000-50A-N7

- Note 1) Be careful to avoid damage or contamination to the O-rings, as this can cause air leakage.
- Note 2) When removing a straight fitting from a valve, after removing the clip, attach tubing or a plug (KJP-02, KQ2P-□□) to the one-touch fitting, and pull it out while holding the tubing or plug. If it is pulled out while holding the release button of the fitting (resin part), the release button may be damaged.
- Note 3) Be sure to turn off the power and stop the supply of air before disassembly. Furthermore, since air may remain inside the actuator, piping and manifold, confirm that the air is completely exhausted before starting any work.
- Note 4) While inserting a tubing into an elbow fitting, hold the main body of the assembly by hand. Failure to do so will exert an undue force on the valve or the fitting, resulting in air leakage or damage.



Series VV100

Specific Product Precautions 3

Be sure to read this before handling.

Refer to back pages 1 and 2 for Safety Instructions, "Handling Precautions for SMC Products" (M-E03-3) for 3 Port Solenoid Valve Precautions.

One-touch Fittings

⚠ Caution

1. Tube attachment/detachment for one-touch fittings

1) Attaching of tubing

(1) Take a tube having no flaws on its periphery and cut it off at a right angle. When cutting the tube, use tube cutters TK-1, 2 or 3. Do not use pinchers, nippers or scissors, etc. If cutting is done with tools other than tube cutters, there is the danger that the tube may be cut diagonally or become flattened, etc., making a secure installation impossible, and causing problems such as the tube pulling out after installation or air leakage. Also allow some extra length in the tube.

(2) Grasp the tube and push it in slowly, inserting it securely all the way into the fitting.

(3) After inserting the tube, pull on it lightly to confirm that it will not come out. If it is not installed securely all the way into the fitting, this can cause problems such as air leakage or the tube pulling out.

2) Detaching of tubing

(1) The 2a and 2b ports use the KJ series, so the tube can be removed by pressing on part of the release button. However, for the 1(P) and 3(E) ports, press the release button evenly as before.

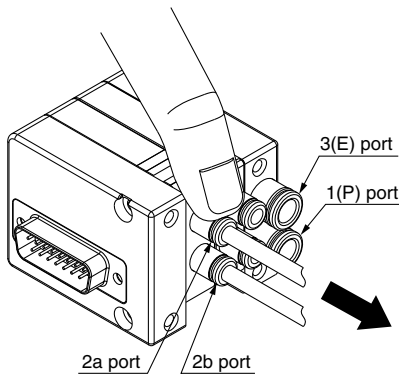

Hold down part of the release button with your finger or a similar tool, as shown in the diagram, and pull out in the direction indicated by the arrow.

(2) Pull out the tube while holding down the release button so that it does not come out. If the release button is not pressed down sufficiently, there will be increased bite on the tube and it will become more difficult to pull it out.

(3) When the removed tube is to be used again, cut off the portion which has been chewed before reusing it. If the chewed portion of the tube is used as is, this can cause trouble such as air leakage or difficulty in removing the tube.

Other Tubing Brands

⚠ Caution

1. When using tube other than SMC brand, confirm the following specifications are satisfied with respect to the outside diameter tolerance of the tube.

- | | |
|------------------------|-------------------------------------|
| 1) Nylon tubing | within ± 0.1 mm |
| 2) Soft nylon tubing | within ± 0.1 mm |
| 3) Polyurethane tubing | within $+0.15$ mm, within -0.2 mm |

Do not use tubing which does not meet these outside diameter tolerances. It may not be possible to connect them, or they may cause other troubles, such as air leakage or the tube pulling out after connection.

How to Use Plug Connector

⚠ Caution

When attaching and detaching a connector, first shut off the electric power and the air supply.

Also, crimp the lead wires and sockets securely.

1. Attaching and detaching connectors

- To attach a connector, hold the lever and connector unit between your fingers and insert straight onto the pins of the solenoid valve so that the lever's pawl is pushed into the groove and locks.
- To detach a connector, remove the pawl from the groove by pushing the lever downward with your thumb, and pull the connector straight out.

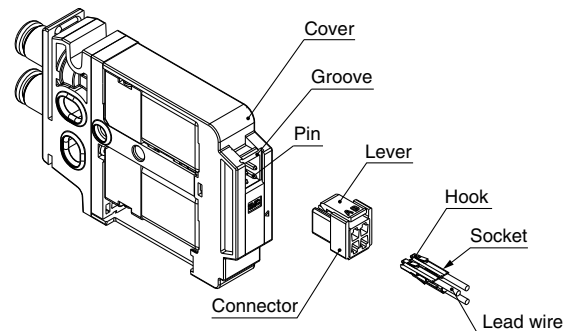

2. Crimping of lead wires and sockets

Peel 3.2 to 3.7 mm of the tip of lead wire, enter the core wires neatly into a socket and crimp it with a special crimp tool. Be careful so that the cover of lead wire does not enter into the crimping part. (Crimping tool: Model no. DXT170-75-1)

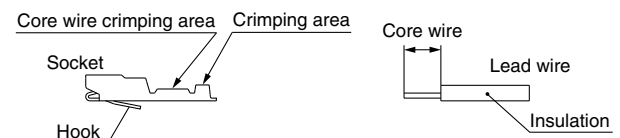

(0.2 to 0.33 mm²
Max. cover diameter: $\phi 1.7$ mm)



Series VV100

Specific Product Precautions 4

Be sure to read this before handling.

Refer to back pages 1 and 2 for Safety Instructions, "Handling Precautions for SMC Products" (M-E03-3) for 3 Port Solenoid Valve Precautions.

How to Use Plug Connector

Caution

3. Attaching and detaching lead wires with sockets

• Attaching

Insert the sockets into the square holes of the connector (with A, B, C, and N indication), and continue to push the sockets all the way in until the lock by hooking into the seats in the connector. (When they are pushed in, their hooks open and they are locked automatically.) Next, confirm that they are locked by pulling lightly on the lead wires.

• Detaching

To detach a socket from a connector, pull out the lead wire while pressing the socket's hook with a stick having a thin tip (approx. 1 mm). If the socket is used again, spread the hook outward.

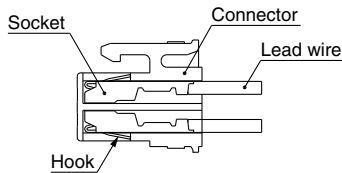

Single solenoid

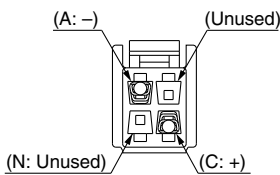

Double solenoid

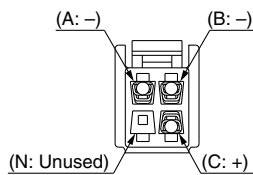

Plug Connector Lead Wire Length

Caution

Plug connector lead wires have a standard length of 300 mm, however, the following lengths are also available.

Connector Assembly Part No.

For single solenoid
SJ3000-46-S-□

For double solenoid
SJ3000-46-D-□

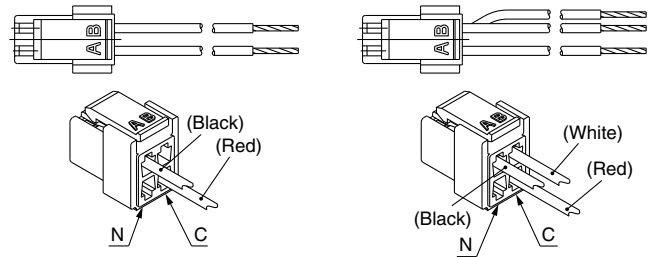

Lead wire length

For single solenoid: SJ3000-46-S-□

For double solenoid: SJ3000-46-D-□

Nil	300 mm
6	600 mm
10	1000 mm
15	1500 mm
20	2000 mm
25	2500 mm
30	3000 mm
50	5000 mm

For single solenoid

Without lead wire: SJ3000-46-S-N
(Connector, Socket x 2 pcs. only)

For double solenoid

Without lead wire: SJ3000-46-D-N
(Connector, Socket x 3 pcs. only)

How to Order

Include the connector assembly part number together with the part number for the plug connector's solenoid valve without connector.

(Example) Lead wire length 2000 mm

V110N-D5MOZ-C4

SJ3000-46-S-20



Series VV100

Specific Product Precautions 5

Be sure to read this before handling.

Refer to back pages 1 and 2 for Safety Instructions, "Handling Precautions for SMC Products" (M-E03-3) for 3 Port Solenoid Valve Precautions.

Connector Assembly for Manifolds (for Junction Common)

Caution

Using the connector assembly (for junction common) for solenoid valves installed in the manifold reduces the labor involved in wiring work because common wiring for all solenoid valves is integrated into a single wire.

Connector Assembly Part No. (for Junction Common)

For single solenoid
SJ3000-46-SC-□

For double solenoid
SJ3000-46-DC-□

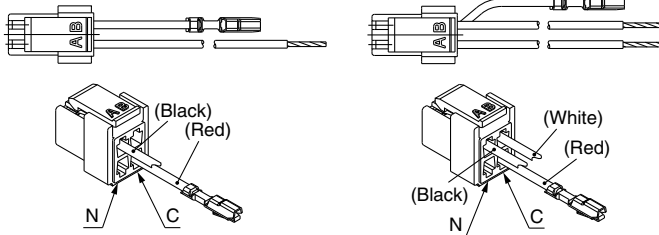

	●Lead wire length	
For single solenoid: SJ3000-46-SC-□	Nil	300 mm
	6	600 mm
	10	1000 mm
	15	1500 mm
	20	2000 mm
	25	2500 mm
	30	3000 mm
	50	5000 mm

How to Order

Indicate the part no. of the connector assembly for the manifold and solenoid valve.

If the arrangement is complicated, specify them by means of the manifold specification sheet.

Note 1) Applications like connectors not wired to a valve is not possible.

Note 2) For the solenoid valve, designate "Without connector (MOZ)" for the connector type.

Note 3) Connector assembly with lead wire for place where the signals are transmitted to the common wiring. (Only the valves of first station and/or last station of manifold are compatible to connector with lead wire for common.)

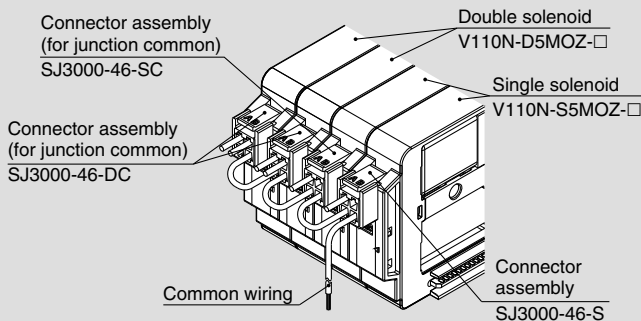

(Example)

VV100-10-04U1-C6	1 set
* V110N-S5MOZ-C4	2 sets
* V110N-D5MOZ-C4	2 sets
* SJ3000-46-S	1 set (Connector assembly for single solenoid)
* SJ3000-46-SC	1 set (Connector assembly for single solenoid (for junction common))
* SJ3000-46-DC	2 sets (Connector assembly for double solenoid (for junction common))

→ The asterisk denotes the symbol for assembly. Prefix it to the part nos. of the solenoid valve, etc.

Wiring Procedure for Connector Assembly (for Junction Common)

Caution

If only connector assembly (for junction common) is ordered, please wire according to the instructions in the diagram below. For details on socket mounting, refer to "How to Use Plug Connector" on the back page 6.

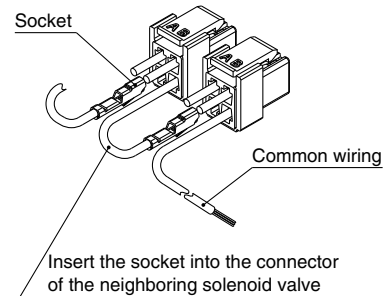

SMC'S GLOBAL MANUFACTURING, DISTRIBUTION AND SERVICE NETWORK

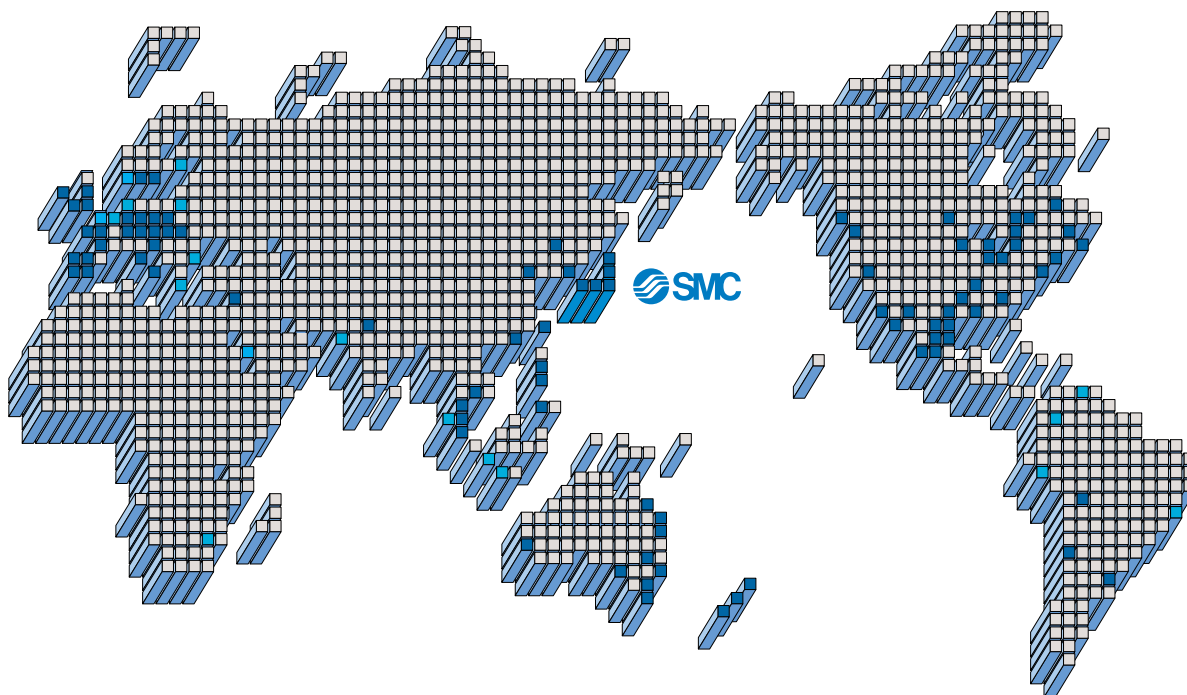

EUROPE

AUSTRIA

SMC Pneumatik GmbH (Austria)

BELGIUM

SMC Pneumatics N.V./S.A.

BULGARIA

SMC Industrial Automation Bulgaria Eood

CROATIA

SMC Industrijska Automatika d.o.o.

CZECH REPUBLIC

SMC Industrial Automation CZ s.r.o.

DENMARK

SMC Pneumatik A/S

ESTONIA

SMC Pneumatics Estonia OÜ

FINLAND

SMC Pneumatics Finland Oy

FRANCE

SMC Pneumatique SA

GERMANY

SMC Pneumatik GmbH

GREECE

SMC Hellas E.P.E.

HUNGARY

SMC Hungary Ipari Automatizálási Kft.

IRELAND

SMC Pneumatics (Ireland) Ltd.

ITALY

SMC Italia S.p.A.

LATVIA

SMC Pneumatics Latvia SIA

LITHUANIA

UAB "SMC Pneumatics"

NETHERLANDS

SMC Pneumatics B.V.

NORWAY

SMC Pneumatics Norway AS

POLAND

SMC Industrial Automation Polska Sp.z.o.o.

ROMANIA

SMC Romania S.r.l.

RUSSIA

SMC Pneumatik LLC

SLOVAKIA

SMC Priemyselna Automatizacia Spol s.r.o.

SLOVENIA

SMC Industrijska Avtomatika d.o.o.

SPAIN/PORTUGAL

SMC España S.A.

SWEDEN

SMC Pneumatics Sweden AB

SWITZERLAND

SMC Pneumatik AG

U.K.

SMC Pneumatics (U.K.) Ltd.

ASIA

CHINA

SMC (China) Co., Ltd.

HONG KONG

SMC Pneumatics (Hong Kong) Ltd.

INDIA

SMC Pneumatics (India) Pvt. Ltd.

MALAYSIA

SMC Pneumatics (S.E.A.) Sdn. Bhd.

PHILIPPINES

Shoketsu SMC Corporation

SINGAPORE

SMC Pneumatics (S.E.A.) Pte. Ltd.

SOUTH KOREA

SMC Pneumatics Korea Co., Ltd.

TAIWAN

SMC Pneumatics (Taiwan) Co., Ltd.

THAILAND

SMC (Thailand) Ltd.

NORTH AMERICA

CANADA

SMC Pneumatics (Canada) Ltd.

MEXICO

SMC Corporation (Mexico), S.A. de C.V.

U.S.A.

SMC Corporation of America

SOUTH AMERICA

ARGENTINA

SMC Argentina S.A.

BOLIVIA

SMC Pneumatics Bolivia S.r.l.

BRAZIL

SMC Pneumáticos do Brasil Ltda

CHILE

SMC Pneumatics (Chile) S.A.

VENEZUELA

SMC Neumatica Venezuela S.A.

OCEANIA

AUSTRALIA

SMC Pneumatics (Australia) Pty. Ltd.

NEW ZEALAND

SMC Pneumatics (N.Z.) Ltd.



Safety Instructions

Be sure to read "Handling Precautions for SMC Products" (M-E03-3) before using.

SMC Corporation

Akihabara UDX 15F,
4-14-1, Sotokanda, Chiyoda-ku, Tokyo 101-0021, JAPAN
Phone: 03-5207-8249 Fax: 03-5298-5362
URL <http://www.smcworld.com>
© 2008 SMC Corporation All Rights Reserved

Specifications are subject to change without prior notice
and any obligation on the part of the manufacturer.

D-DN

1st printing MV printing MV 16400DN Printed in Japan.

This catalog is printed on recycled paper with concern for the global environment.