

Series VQ1000 Base Mounted Plug-in Unit

How to Order Manifold

VV5Q 1 1-08 C6 F U1

Series
1 VQ1000

Manifold
1 Plug-in unit

Stations
01 1 station
:
:

The maximum and minimum number of stations are varied depending on kit. (Refer to the table below.)

Option

Symbol	Option
Nil	None
2	200/220 VAC models (Applicable to F and L kits)
B	With back pressure check valve ⁽²⁾
D	DIN rail mounting
G1	1 set of regulator unit ⁽³⁾
G2	2 sets of regulator unit ⁽³⁾
G3	3 sets of regulator unit ⁽³⁾
J	With vacuum ejector unit ⁽⁴⁾
K	Special wiring specifications (Not double wiring) ⁽⁵⁾
N	With name plate
R	External pilot ⁽⁶⁾
S	Built-in silencer, direct exhaust

Note 1) When two or more symbols are specified, indicate them alphabetically. Example) -BRS

Note 2) Models with a suffix "-B" have check valves for prevention of back pressure at all manifold stations. If not all stations need this check valve, specify the stations where check valves are installed by using the manifold specification sheet.

Note 3) Specify the mounting position in the manifold specification sheet.

Note 4) Refer to page 2-4-170 for the details of ejector mounted styles. A combination of "J" and "N" is unavailable.

Note 5) Specify the wiring by means of the manifold specification sheet. (Except L kit)

Note 6) Indicate "R" for the valve with external pilot.

Cylinder port

Symbol	Port size	Symbol	Port size
C3	With One-touch fitting for ø3.2	L6	W/ elbow One-touch fitting ø6 for top piping
C4	With One-touch fitting for ø4	L5	Elbow M5 thread for top piping
C6	With One-touch fitting for ø6	B3	W/ elbow One-touch fitting ø3.2 for bottom piping
M5	M5 thread	B4	W/ elbow One-touch fitting ø4 for bottom piping
CM	With mixed size/with port plug ⁽¹⁾	B6	W/ elbow One-touch fitting ø6 for bottom piping
L3	W/ elbow One-touch fitting ø3.2 for top piping	B5	Elbow M5 thread for bottom piping
L4	W/ elbow One-touch fitting ø4 for top piping	LM	Mixed size for elbow piping

Note 1) Specify "Mixed size/with port plug" in the manifold specification sheet.
Note 2) Inch-size One-touch fittings are also available. For details, refer to page 2-4-179.
Note 3) M5 fittings for M5 thread are attached without being incorporated.



Simple specials are available with SMC Simple Specials System. For details about applicable models, please contact SMC.

Kit/Electrical entry/Cable length

F kit (D-sub connector)		P kit (Flat ribbon cable connector)		J kit (Flat ribbon cable connector (20P))		G Kit (Flat ribbon cable connector with power supply terminal block)	
P. 2-4-130		P. 2-4-134		P. 2-4-138		P. 2-4-142	
Kit	U0	Kit	U0	Kit	U0	Kit	U0
	U1		U1		U1		U1
	U2		U2		U2		U2
	U3		U3		U3		U3
	S0		S0		S0		S0
	S1		S1		S1		S1
	S2		S2		S2		S2
	S3		S3		S3		S3
	Without cable		Without cable		Without cable		Without cable
	With cable (1.5 m)		With cable (1.5 m)		With cable (1.5 m)		With cable (1.5 m)
	With cable (3 m)		With cable (3 m)		With cable (3 m)		With cable (3 m)
	With cable (5 m)		With cable (5 m)		With cable (5 m)		With cable (5 m)
	2 to 24 stations		2 to 24 stations		2 to 16 stations		2 to 16 stations

Note 1) Besides the above, F and P kits with different number of pins are available. Refer to page 2-4-177 for details.
Note 2) For details, refer to page 2-4-178.

How to Order Valves

VQ 1 1 0 0 Y 5

Series
1 VQ1000

Type of actuation
1 2 position single
2 Metal 2 position double
2 Rubber 2 position double
3 3 position closed center
3 3 position exhaust center
3 3 position pressure center
4 4 position dual 3 port valve
4 4 position dual 3 port valve
4 4 position dual 3 port valve

Seal
0 Metal seal
1 Rubber seal

Manual override
Nil: Non-locking push type (Tool required)
B: Push-locking slotted type
C: Locking type (Manual)

Light/Surge voltage suppressor
Nil Yes
E (Note) None
Note) Inapplicable to the S kit.

Function

Symbol	Specifications	DC	AC
Nil	Standard type	(1.0 W)	○ (Note)
H	High pressure type	(1.5 W)	—
Y	Low wattage type	(0.5 W)	—

Note) For power consumption of AC type, refer to page 2-4-129.
Note) For external pilot and negative COM specifications, refer to "Option" on pages 2-4-178 to 2-4-179.

Note) Rubber seal type only.

Coil voltage

1	100 VAC (50/60 Hz)
2 (Note)	200 VAC (50/60 Hz)
3	110 VAC (50/60 Hz)
4 (Note)	220 VAC (50/60 Hz)
5	24 VDC
6	12 VDC

Note) 200/220 VAC models are applicable to F and L kits.

How to Order Manifold Assembly

Example

Single solenoid (24 VDC)
VQ1100-5 (4 sets)

Double solenoid (24 VDC)
VQ1200-5 (4 sets)

Blanking plate
VQ1000-10A-1 (1 set)

Manifold base (9 stations)
VV5Q11-09C6FU2

D-sub connector

F kit (D-sub connector)

Cylinder ports
C6: With One-touch fitting for ø6

Stations

D-sub connector

3m

VV5Q11-09C6FU2 1 set (F kit 9 station manifold base no.)
*VQ1100-5 4 sets (Single solenoid part no.)
*VQ1200-5 4 sets (Double solenoid part no.)
*VV1000-10A-1 1 set (Blanking plate part no.)

The asterisk denotes the symbol for assembly. Prefix it to the part nos. of the solenoid valve, etc.

Specify the part numbers for valves and options together beneath the manifold base part number. Besides, when the arrangement will be complicated, specify them by means of the manifold specification sheet.

VQC

SQ

VQ0

VQ4

VQ5

VQZ

VQD

T kit (Terminal box)

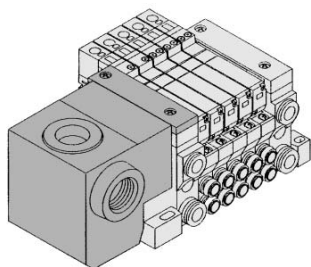

P. 2-4-146

L kit (Lead wire cable)

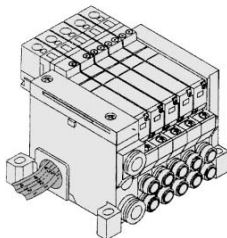

P. 2-4-150

S kit (Serial transmission unit)

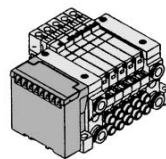

The valve is equipped with an indicator light and surge voltage suppressor, and the voltage is 24 VDC. The dust proof SI unit is also available. Refer to page 2-4-154 for details.

P. 2-4-154

Kit T O Terminal block box 2 to 24 stations (2)

Kit L 0 With cable (0.6 m) 1 to 8 stations
1 With cable (1.5 m)
2 With cable (3 m)

Kit S	Description	Max. stations
0	Without SI unit	
A	With general type SI unit (Series EX300)	
B	Mitsubishi Electric Corp.: MELSECNET/MINI-S3 Data Link System	
C	OMRON Corp.: SYSBUS Wire System	
D	SHARP Corp.: Satellite I/O Link System	
E	Matsushita Electric Works: MEWNET-F System	
F1	NKE Corp.: Uni-wire System (16 output points)	
G	Rockwell Automation: Allen Bradley Remote I/O (RIO) System	
H	NKE Corp.: Uni-wire H System	
J1	SUNX Corp.: S-LINK System (16 output points)	
J2	SUNX Corp.: S-LINK System (8 output points)	Max. 8 stations
K	Fuji Electric Co.: T-LINK Mini System	
Q	DeviceNet, CompoBus/D (OMRON Corp.)	Max. 16 stations
R1	OMRON Corp.: CompoBus/S System (16 output points)	
R2	OMRON Corp.: CompoBus/S System (8 output points)	Max. 8 stations
V	Mitsubishi Electric Corp.: CC-LINK System	Max. 16 stations

Manifold Option

Blanking plate assembly
VVQ1000-10A-1

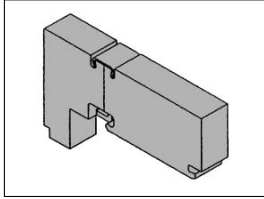

SUP block plate
VVQ1000-16A

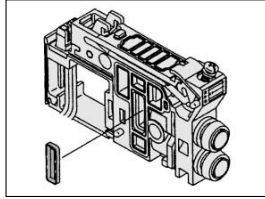

Double check block
VQ1000-FPG-□□

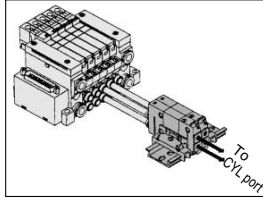

2 stations matching fitting assembly
VVQ1000-52A-C8

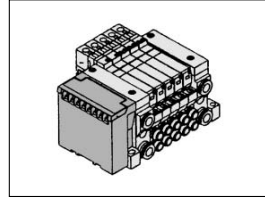

Blanking plug
KQ2P-
□□□□

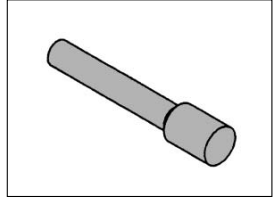

Individual SUP spacer
VVQ1000-P-1-C6

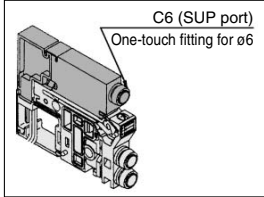

EXH block base assembly
VVQ1000-19A-
□□□□□□

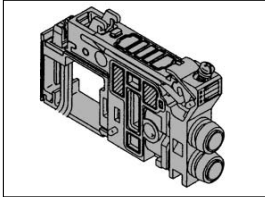

Elbow fitting assembly
VVQ1000-F-L-
□□□□□□

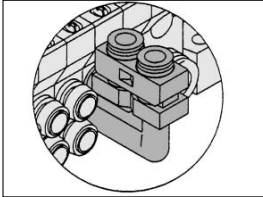

Silencer (For EXH port)
AN200-KM8/AN203-KM8

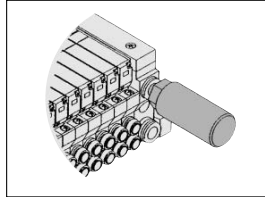

Blanking plate with connector
VVQ1000-1C□-□

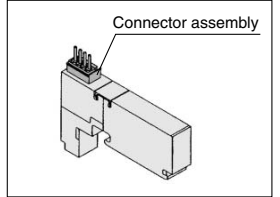

Individual EXH spacer
VVQ1000-R-1-C6

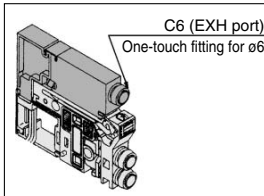

Back pressure check valve assembly [-B]
VVQ1000-18A

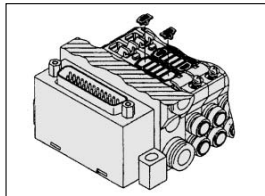

DIN rail mounting bracket [-D]
VVQ1000-57A

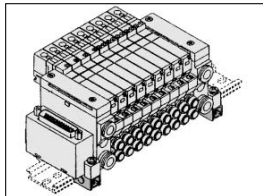

Regulator unit
VVQ1000-AR-1

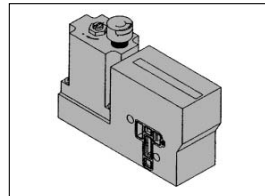

- For cylinder port fittings part no., refer to page 2-4-175.
- For replacement parts, refer to page 2-4-227.

With vacuum ejector unit
[-J□]

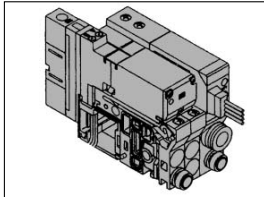

Name plate [-N]
VVQ1000-_{NC} Station (1 to Max. stations)

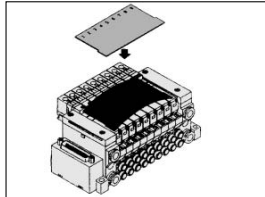

Built-in silencer,
direct exhaust [-S]

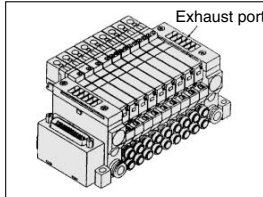

Port plug
VVQ0000-58A

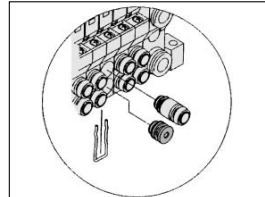

Standard Specifications

JIS Symbol

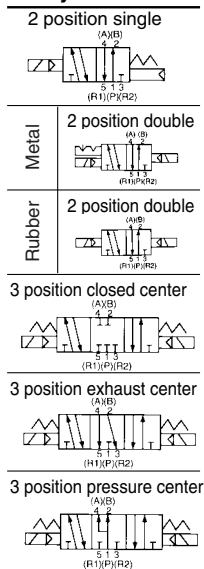

Valve specifications	Valve construction	Metal seal	Rubber seal	
	Fluid	Air/Inert gas	Air/Inert gas	
	Maximum operating pressure	0.7 MPa (High pressure type: 0.8 MPa)		
	Minimum operating pressure	Single	0.1 MPa	0.15 MPa
		Double	0.1 MPa	0.1 MPa
		3 position	0.1 MPa	0.2 MPa
	Ambient and fluid temperature	-10 to 50°C ⁽¹⁾		
	Lubrication	Not required		
	Manual override	Push type/Locking type (Tool required, Manual type) Option		
	Impact/Vibration resistance ⁽²⁾	150/30 m/s ²		
Enclosure	Dust-protected, Dust tight/Low jetproof type (IP65) ⁽⁵⁾			
Solenoid	Coil rated voltage	12, 24 VDC, 100, 110, 200, 220 VAC (50/60 Hz)		
	Allowable voltage fluctuation	±10% of rated voltage		
	Coil insulation type	Class B or equivalent		
	Power consumption (Current)	24 VDC	1 W DC (42 mA), 1.5 W DC (63 mA) ⁽³⁾ , 0.5 W DC (21 mA) ⁽⁴⁾	
		12 VDC	1 W DC (83 mA), 1.5 W DC (125 mA) ⁽³⁾ , 0.5 W DC (42 mA) ⁽⁴⁾	
		100 VAC	Inrush 1.2 VA (12 mA), Holding 1.2 VA (12 mA)	
		110 VAC	Inrush 1.3 VA (12 mA), Holding 1.3 VA (12 mA)	
200 VAC		Inrush 2.4 VA (12 mA), Holding 2.4 VA (12 mA)		
220 VAC	Inrush 2.6 VA (12 mA), Holding 2.6 VA (12 mA)			

VQC

SQ

VQ0

VQ4

VQ5

VQZ

VQD



Note 1) Use dry air to prevent condensation when operating at low temperatures.
 Note 2) Impact resistance ... No malfunction occurred when it is tested with a drop tester in the axial direction and at the right angles to the main valve and armature in both energized and de-energized states every once for each condition. (Values at the initial period)
 Vibration resistance ... No malfunction occurred in a one-sweep test between 45 and 2000 Hz. Test was performed at both energized and de-energized states in the axial direction and at the right angles to the main valve and armature. (Values at the initial period)
 Note 3) Value for high voltage type (1.5 W)
 Note 4) Value for low voltage type (0.5 W)
 Note 5) Dusttight/Low jetproof type (IP65) is available on T, L, S and M kits of VQ2000.

Manifold Specifications

Series	Base model	Type of connection	Porting specifications		Applicable stations ⁽²⁾	Applicable solenoid valve	5 station weight (g)	
			Port location	Port size ⁽¹⁾				
VQ1000	VV5Q11-□□□	<ul style="list-style-type: none"> F kit—D-sub connector P kit—Flat ribbon cable connector J kit—Flat ribbon cable connector (20P) G kit—Flat ribbon cable connector with terminal block T kit—Terminal box L kit—Lead wire cable S kit—Serial transmission unit 	Side	1(P), 3(R)	4(A), 2(B)	F, P, T kits 2 to 24 stations (J, G, S kit) 2 to 16 stations (L kit) 1 to 8 stations	VQ1□00 VQ1□01	628 (Single) 759 (Double, 3 position)
				C8 (ø8) Option Built-in silencer, direct exhaust	C3 (ø3.2) C4 (ø4) C6 (ø6) M5 (M5 thread)			
VQ2000	VV5Q21-□□□	<ul style="list-style-type: none"> F kit—D-sub connector P kit—Flat ribbon cable connector J kit—Flat ribbon cable connector (20P) G kit—Flat ribbon cable connector with terminal block T kit—Terminal box L kit—Lead wire cable S kit—Serial transmission unit M kit—Multi-connector 	Side	C10 (ø10) Option Built-in silencer, direct exhaust	C4 (ø4) C6 (ø6) C8 (ø8)	(F, P kits) 2 to 24 stations (J, G, S kit) 2 to 16 stations (L kit) 1 to 8 stations (T kit) 2 to 20 stations	VQ2□00 VQ2□01	1051 (Single) 1144 (Double, 3 position)

Note 1) Inch-size One-touch fittings are also available. For details, refer to page 2-4-179.
 Note 2) For details, refer to page 2-4-178.

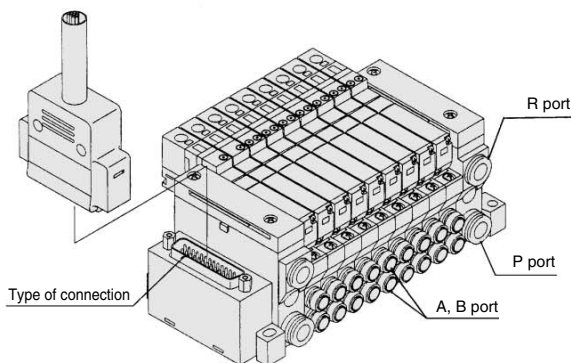

VV5Q11

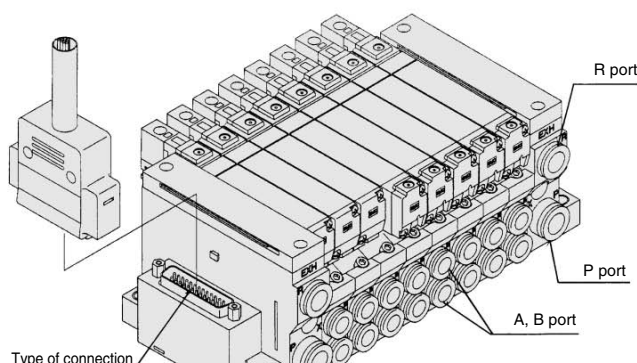

VV5Q21

VQ1000/2000 Kit (Lead wire cable)

IP65 compliant

- Direct electrical entry. Models with one or more stations are available.
- (SUP) and R (EXH) ports are provided on one side for further space savings.
- Maximum stations are 8.
- Enclosure: Dusttight/Low jetproof type (IP65) compliant (Series VQ2000)

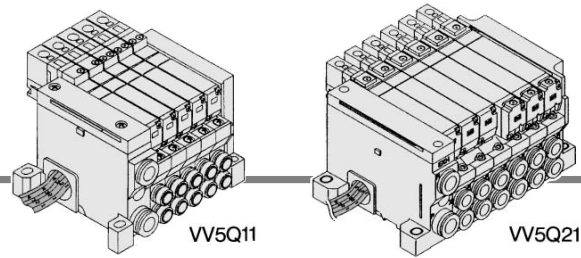

Manifold Specifications

Series	Porting specifications		Applicable stations
	Port location	Port size	
VQ1000	Side	1(P), 3(R) 4(A), 2(B)	Max. 8 stations
VQ2000	Side	C8 C6, C8	Max. 8 stations

Wiring specifications: Positive COM ●

Three lead wires are attached to each station regardless of the type of valve which is mounted. The red wire is for COM connection.

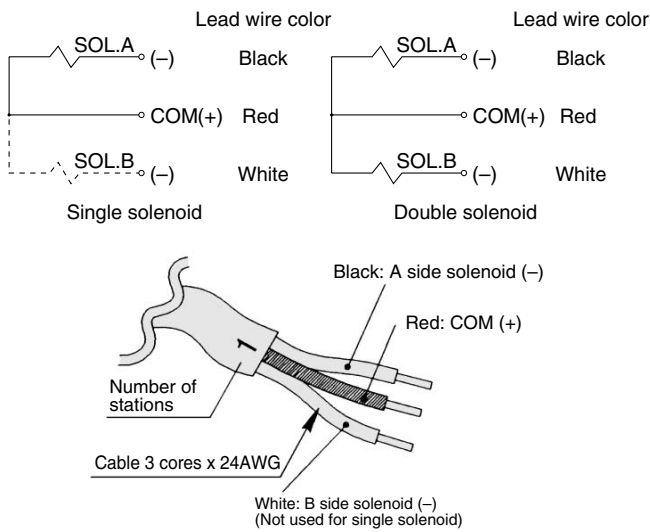

Use any of the following cable lead wire assembly to change the lead wire length:

Lead Wire Assembly with Connector

Lead wire length	Part no.
0.6 m	VVQ1000-84A-6-*
1.5 m	VVQ1000-84A-15-*
3 m	VVQ1000-84A-30-*

* No. of stations 1 to 8

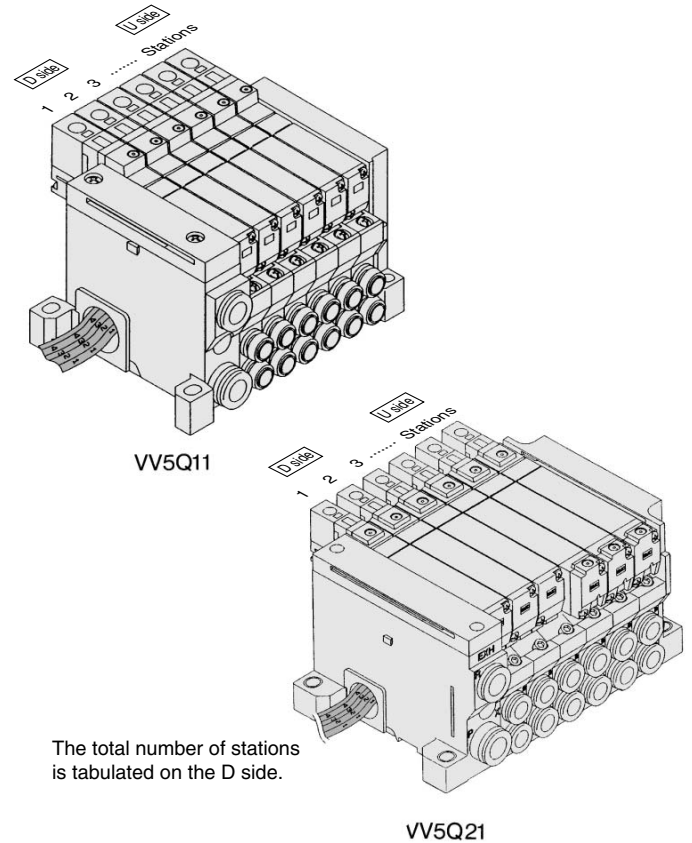

The total number of stations is tabulated on the D side.

How to Order Manifold

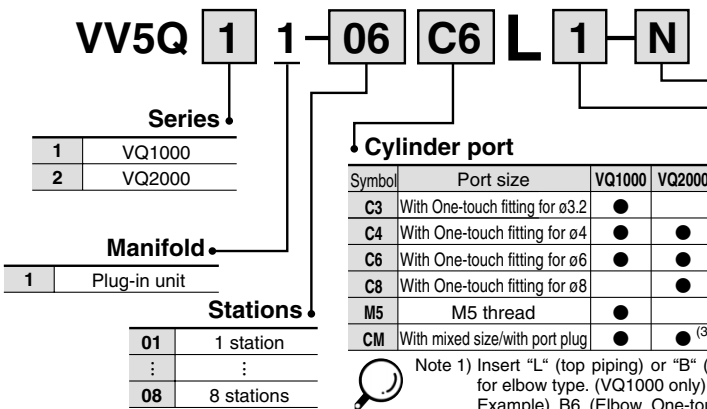

Note) For negative common specifications, refer to "Option" on page 2-4-178.

Cylinder port

Symbol	Port size	VQ1000	VQ2000
C3	With One-touch fitting for ø3.2	●	
C4	With One-touch fitting for ø4	●	●
C6	With One-touch fitting for ø6	●	●
C8	With One-touch fitting for ø8		●
M5	M5 thread	●	
CM	With mixed size/with port plug	●	● ⁽³⁾

Note 1) Insert "L" (top piping) or "B" (bottom piping) for elbow type. (VQ1000 only)
Example) B6 (Elbow One-touch fittings for ø6, bottom piping.)

Note 2) Indicate "LM" for models with elbow fittings and mixed cylinder port sizes.

Note 3) Specify "Mixed size/with port plug" in the manifold specification sheet.

Note 4) Inch-size One-touch fittings are available. For details, refer to page 2-4-179.

Option

Symbol	Option	VQ1000	VQ2000	Note
Nil	None	●	●	
B	With back pressure check valve	●	●	(2)
D	DIN rail mounting style	●	●	
G1	1 set of regulator unit	●		(3)
G2	2 sets of regulator units	●		(3)
G3	3 sets of regulator units	●		(3)
J□	With vacuum ejector unit	●		(4)
N	With name plate	●	●	
R	External pilot	●	●	(5)
S	Built-in silencer, direct exhaust	●	●	
W	Enclosure: Dusttight/Low jetproof type (IP65)		●	

Note 1) When two or more symbols are specified, indicate them alphabetically. Example) -BRS

Note 2) Models with a suffix "-B" have check valves for prevention of back pressure at all manifold stations. If not all stations need this check valve, specify the stations where check valves are installed by the manifold specification sheet.

Note 3) Specify the mounting position in the manifold specification sheet.

Note 4) Refer to page 2-4-170 for the details of ejector mounted styles. A combination of "J" and "N" is unavailable.

Note 5) Indicate "R" for the valve with external pilot.

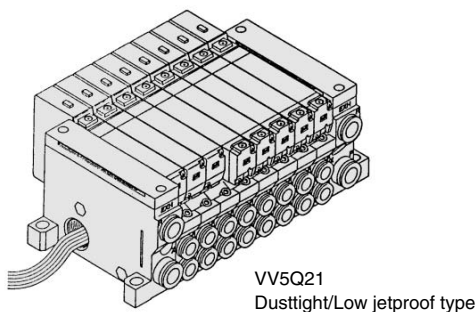

● Wiring specifications: Negative COM (Option)

Three lead wires are attached to each station regardless of the type of valve which is mounted. The black wire is for COM connection.

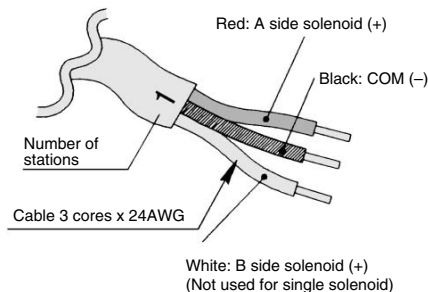
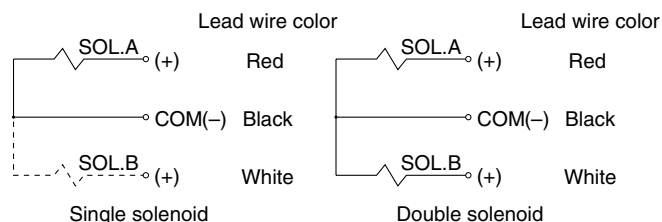

Lead Wire Assembly with Connector

Lead wire length	Part no.
0.6 m	VVQ1000-84AN-6-*
1.5 m	VVQ1000-84AN-15-*
3 m	VVQ1000-84AN-30-*

* No. of stations 1 to 8



Note) When using the negative common specifications, use valves for negative common. For negative common specifications, refer to "Option" on page 2-4-178.

VQC

SQ

VQ0

VQ4

VQ5

VQZ

VQD

How to Order Valves

VQ 1 1 0 0 Y 5

Series

1	VQ1000
2	VQ2000

Type of actuation

1	2 position single
2	2 position double
3	3 position closed center
4	3 position exhaust center
5	3 position pressure center

Seal

0	Metal seal
1	Rubber seal

Function

Symbol	Specifications	DC	AC
Nil	Standard type	(1.0 W) ○	○ ^{Note)}
H	High pressure type	(1.5 W) ○	—
Y	Low wattage type	(0.5 W) ○	—

Enclosure

Nil	Dusttight
W	Dusttight/Low jetproof ^{Note)} type (IP65)

Note) VQ2000 only.

Manual override

Nil	Non-locking push type (Tool required)
B	Locking type (Tool required)
C	Locking type (Manual)

Light/Surge voltage suppressor

Nil	Yes
E	None

Coil voltage

1	100 VAC (50/60 Hz)
2	200 VAC (50/60 Hz)
3	110 VAC (50/60 Hz)
4	220 VAC (50/60 Hz)
5	24 VDC
6	12 VDC

Note) For external pilot and negative COM specifications, refer to "Option" on 2-4-178 to 2-4-179.

Note) For power consumption of AC type, refer to page 2-4-129.

How to Order Manifold Assembly

Specify the part numbers for valves and options together beneath the manifold base part number.

<Example>

Lead wire kit with cable (3 m)

- VV5Q11-06C6L2 1 set—Manifold base no.
- *VQ1100-5 2 sets—Valve part no. (Stations 1 to 2)
- *VQ1200-5 2 sets—Valve part no. (Stations 3 to 4)
- *VQ1300-5 1 set—Valve part no. (Station 5)
- *VVQ1000-10A-1 ... 1 set—Blanking plate part no. (Station 6)

Prefix the asterisk to the part nos. of the solenoid valve, etc.

Write sequentially from the 1st station on the D side. When part nos. written collectively are complicated, specify by using the manifold specification sheet.

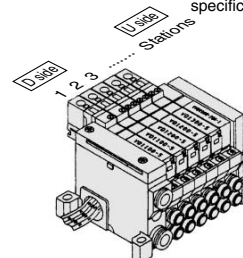

The broken lines indicate DIN rail mounting style [-D].

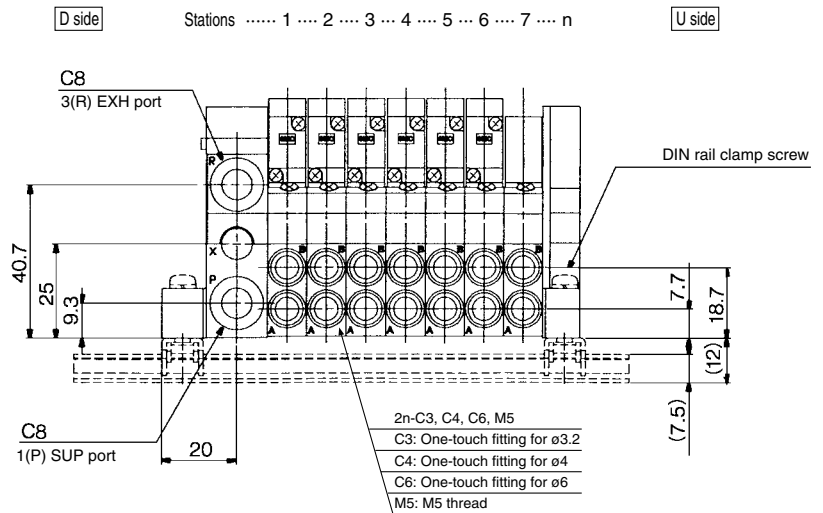
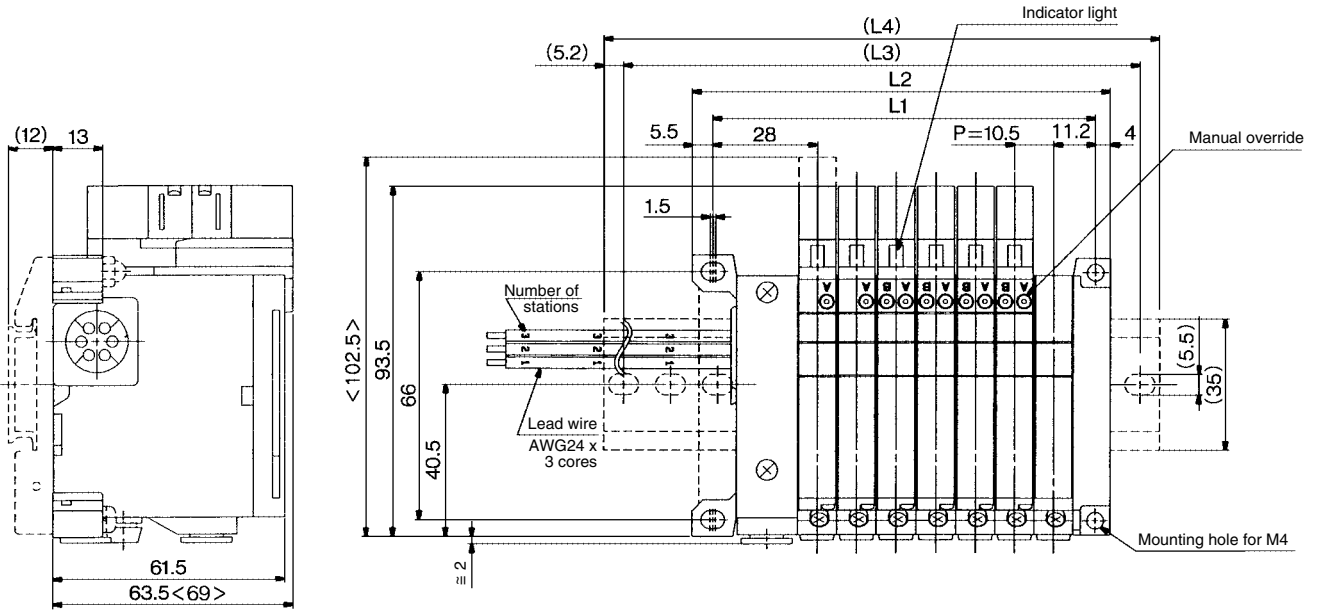

< >: AC

Dimensions

Formula L1 = 16n + 35, L2 = 16n + 47 n: Station (Maximum 8 stations)

L	n	1	2	3	4	5	6	7	8
L1		39	49.5	60	70.5	81	91.5	102	112.5
L2		48.5	59	69.5	80	90.5	101	111.5	122
(L3)		75	87.5	87.5	100	112.5	125	137.5	150
(L4)		85.5	98	98	110.5	123	135.5	148	160.5

Vacuum ejector unit style: Formula L1 = 10.5n + 28.5 + (Number of ejector units x 26.7)

L2 = 10.5n + 38 + (Number of ejector units x 26.7)

L4 is L2 plus about 30.

Series VQ1000

Manifold Option Parts for VQ1000

Blanking plate assembly VVQ1000-10A-1

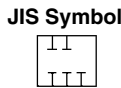

It is used by attaching on the manifold block for being prepared for removing a valve for maintenance reasons or planning to mount a spare valve, etc.

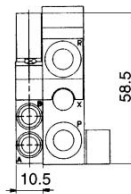
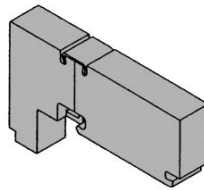

Individual SUP spacer VVQ1000-P-1-C6

When the same manifold is to be used for different pressures, individual SUP spacers are used as SUP ports for different pressures. (One station space is occupied.)

Block both sides of the station, for which the supply pressure from the individual SUP spacer is used, with SUP block plates. (Refer to the application ex.)

* Specify the spacer mounting position and SUP block plate position on the manifold specification sheet.

The block plate are used in two places for one set. (Two SUP block plates for blocking SUP station are attached to the individual SUP spacer.)

* Electric wiring is connected to the position of the manifold station where the individual SUP spacer is mounted.

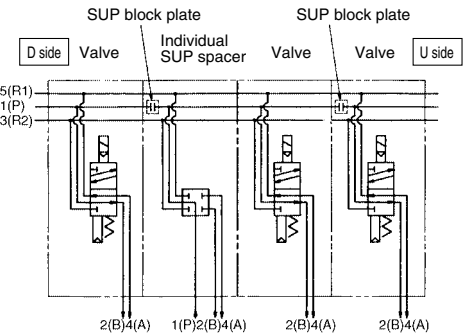
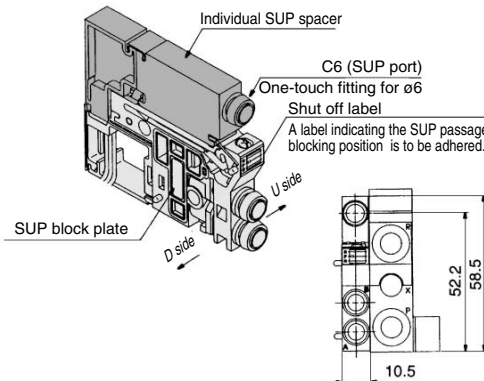

Individual EXH spacer VVQ1000-R-1-C6

When valve exhaust affects other stations due to the circuit configuration, this spacer is used for individual valve exhaust. (One station space is occupied.)

Block both sides of the individual valve EXH station. (See example)

* Specify the mounting position, as well as the EXH block base or EXH block plate position on the manifold specification sheet. The block plate are used in two places for one set. (Two EXH block plates for blocking EXH station are attached to the individual EXH spacer.)

* An EXH block base assembly is used in the blocking position when ordering an EXH spacer incorporated with a manifold no. However, do not order an EXH block base assembly because it is attached to the spacer.

When separately ordering an individual EXH spacer, separately order an EXH block base assembly because it is not attached to the spacer.

* Electric wiring is connected to the position of the manifold station where the individual EXH spacer is mounted.

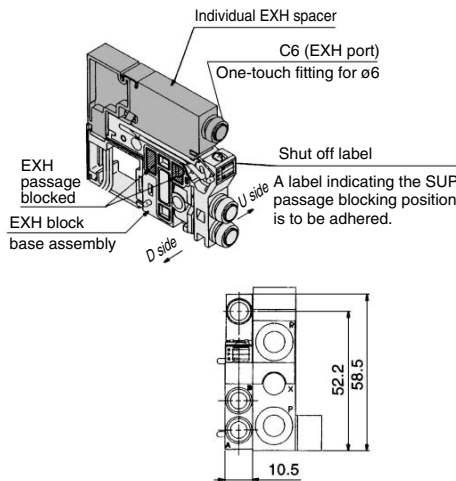

Description/Model		Stations						
		1	2	3	4	5	6	7
Valve	Single	●	●	●				
Option	Individual EXH spacer VVQ1000-R-1-C6		●					
	EXH shut off position: Specify 2 places.	●		●				

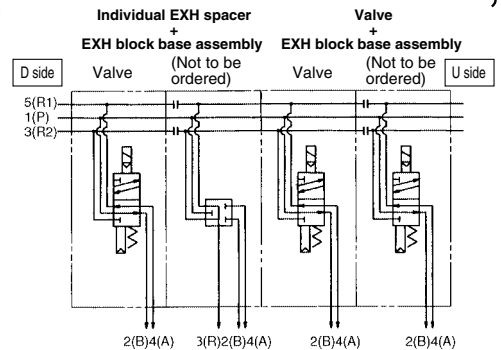

SUP block plate VVQ1000-16A

When different pressures, high and low, are supplied to one manifold, a SUP block plate is inserted between the stations under different pressures.

* Specify the number of stations on the manifold specification sheet.

<Shut off label>

When using block plates for SUP passage, indication label for confirmation of the blocking position from outside is attached. (One label of each)

* When ordering a block plate incorporated with the manifold no., a block indication label is attached to the manifold.

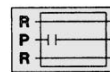
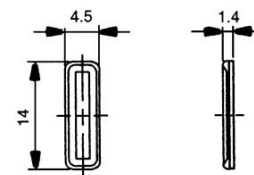
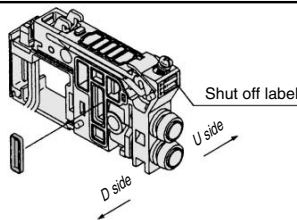

SUP passage block

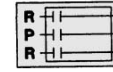

SUP/EXH passage blocked

Blanking plate with connector VVQ1000-1C-

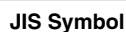

Style of manifold	Connector	Lead wire length (mm)			
		Nil	300	20	2000
1	VV5Q11	6	600	25	2500
		10	1000	30	3000
		15	1500		

Blanking plate with a connector for individually outputting electricity to drive a single valve or equipment that are not on the manifold base.

* When "N" is suffixed to the nameplate, the plate will be different from a standard shape.

Note) Electric current should be 1A or less. (Including the mounted valves.)

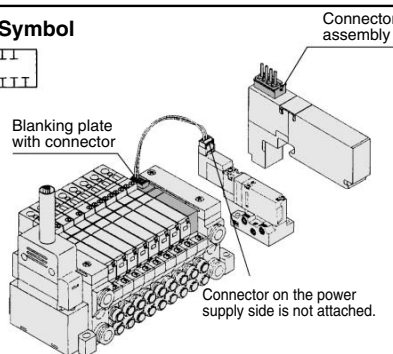

Connector assembly part no. AXT661-43 A-6

Lead wire length: L	Lead wire length: L	
	Nil	300 mm
43	6	600 mm
44	10	1000 mm
	20	2000 mm
	30	3000 mm

Lead wire color: Black
Lead wire color: Red
Lead wire color: White

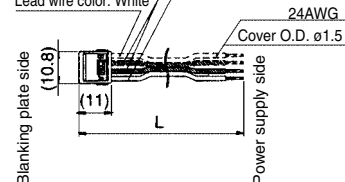

EXH block base assembly
VVQ1000-19A-□ (C3, C4, C6, M5)

Manifold block assembly
Electrical entry

F1	For F kit (2 to 12 stations)/Double wiring
F2	For F kit (13 to 24 stations)/Double wiring
F3	For F kit (2 to 24 stations)/Single wiring
P1	For P, G, T, S kit (2 to 12 stations)/Double wiring
P2	For P, G, T, S kit (13 to 24 stations)/Double wiring
P3	For P, G, T, S kit (2 to 24 stations)/Single wiring
L0*	L0 kit
L1*	L1 kit
L2*	L2 kit

* 1 to 8 stations

The manifold block assembly is used between stations for which exhaust is desired to be divided when valve exhaust affects other stations due to the circuit configuration. The EXH passage on the D-side is blocked in the EXH block base assembly. It is also used in combination with an individual EXH spacer for individual exhaust.

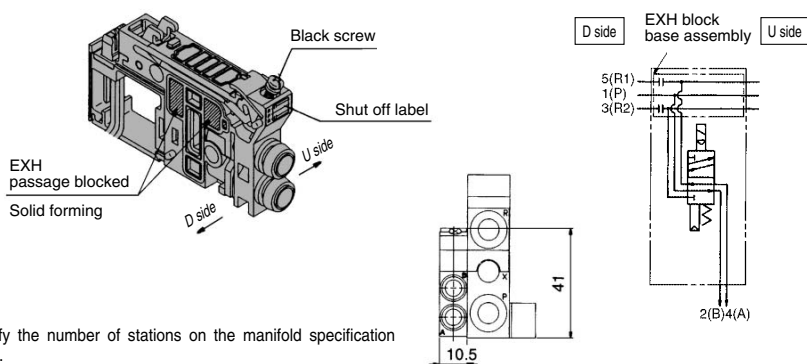

- * Specify the number of stations on the manifold specification sheet.
- * When ordering by using the manifold specification form, specify the EXH block base assembly no. by adding suffix "*" below the manifold no.

<Blocking indication label>

When blocking the EXH passage with an EXH block base assembly, indication label for confirmation of the blocking position from outside is attached. (One label for each)

- * When ordering a EXH block base incorporated with the manifold no., a block indication label is attached to the manifold.

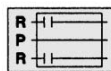

EXH passage blocked

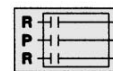

SUP/EXH passage blocked

Back pressure check valve assembly [-B]
VVQ1000-18A

It prevents cylinder malfunction caused by other valve exhaust. Insert it into R (EXH) port on the manifold side of a valve which is affected. It is effective when a single action cylinder is used or an exhaust center type solenoid valve is used.

- Note) When a check valve for back pressure prevention is desired, and is to be installed only in certain manifold stations, write clearly the part no. and specify the number of stations by using the manifold specification sheet.

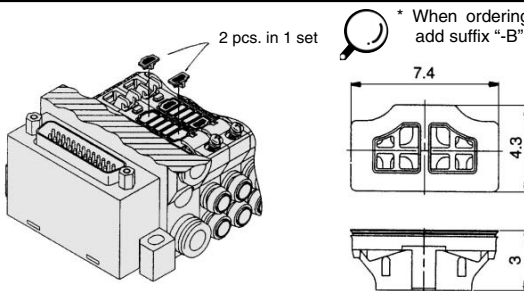

- * When ordering assemblies incorporated with a manifold, add suffix "-B" to the manifold no.

- (Precautions)
1. The back pressure check valve assembly parts with a check valve structure. However, as slight air leakage is allowed for the back pressure, take care the exhaust air will not be throttled at the exhaust port.
 2. When a back pressure check valve is mounted, the effective area of the valve will decrease, by about 20%.

Name plate [-N]
VVQ1000-NC N-Station (1 to Max. stations)

It is a transparent resin plate for placing a label that indicates solenoid valve function, etc. Insert it into the groove on the side of the end plate and bend it as shown in the figure.

- * When the blanking plate with connector is mounted, it automatically will be "VVQ1000-NC-n" with an option symbol [-N]

N: Standard
 NC: For mounting blanking plate with connector

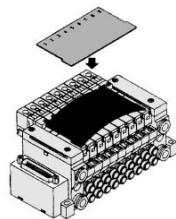

- * When ordering assemblies incorporated with a manifold, add suffix "-N" to the manifold no.

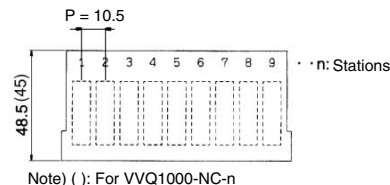

Blanking plug (For One-touch fittings)

KQ2P-²³/₀₄/₀₆/₀₈

It is inserted into an unused cylinder port and SUP/EXH ports. Purchasing order is available in units of 10 pieces.

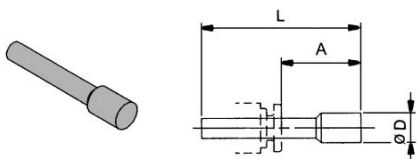

Dimensions

Applicable fittings size od	Model	A	L	D
3.2	KQ2P-23	16	31.5	3.2
4	KQ2P-04	16	32	6
6	KQ2P-06	18	35	8
8	KQ2P-08	20.5	39	10

Port plug
VVQ000-58A

The plug is used to block the cylinder port when using a 4 port valve as a 3 port valve.

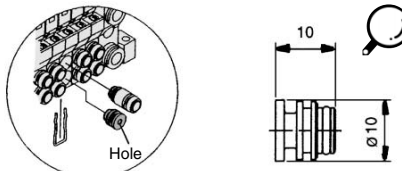

- * When ordering a plug incorporated with a manifold, indicate "CM" for the port size in the manifold no., as well as, the mounting position and number of stations and cylinder port mounting positions, A and B, on the manifold specification sheet.

- * Lightly screw an M3 screw in the port plug hole and pull it for removal.

Elbow fitting assembly
VVQ1000-F-L (C3, C4, C6, M5)

It is used for piping that extends upward or downward from the manifold.

When installing it in part of the manifold stations, specify the assembly no. and the mounting position and number of stations by means of the manifold specification sheet.

- * When mounting elbow fittings assembly on the edge of manifold station and a silencer on EXH port, select a silencer, AN203-KM8. Silencer (AN200-KB8) is interfered with fittings.

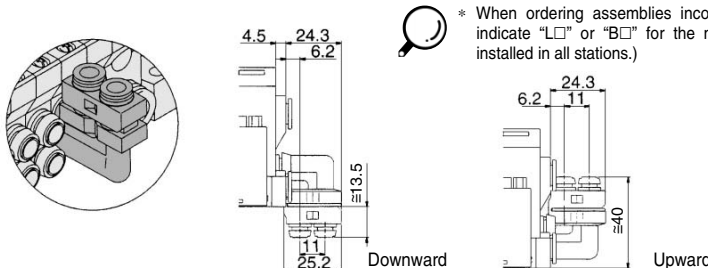

- * When ordering assemblies incorporated with a manifold, indicate "L□" or "B□" for the manifold port size. (When installed in all stations.)

Series VQ1000

Manifold Option Parts for VQ1000

DIN rail mounting bracket

VVQ1000-57A

It is used for mounting a manifold on a DIN rail. The DIN rail mounted bracket is fixed to the manifold end plate. (The specification is the same as that for the option "-D".)

1 set of DIN rail mounting bracket is used for 1 manifold (2 DIN rail mounting brackets).

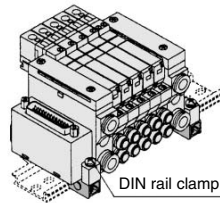

* When ordering assemblies incorporated with a manifold, add suffix "D" to the manifold no.

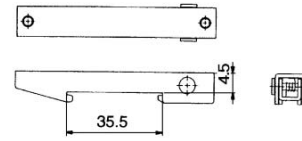

Mounting screws are attached

Built-in silencer, Direct exhaust [-S]

This is a type with an exhaust port a top the manifold end plate. The built-in silencer exhibits an excellent noise suppression effect. (Silencing effect: 30 dB)



Note) A large quantity of drainage generated in the air source results in exhaust of air together with drainage. For maintenance, refer to page 2-4-176.

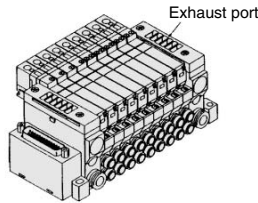

* When ordering assemblies incorporated with a manifold, add suffix "S" to the manifold no.

2 stations matching fitting assembly

VVQ1000-52A-C8

For driving a cylinder with a large bore, valves for two stations are operated to double the flow rate. This assembly for the cylinder port is used in that case. The assembly is equipped with One-touch fittings for a ø8 bore.

* The bore for the manifold no. is "CM".

Clearly indicate the 2 station matching fitting assembly no., and specify the number of stations and positions by means of the manifold specifications.

* In 2 station matching fitting assembly, a special clip which is combined in one-piece of 2 stations is attached as a holding clip.

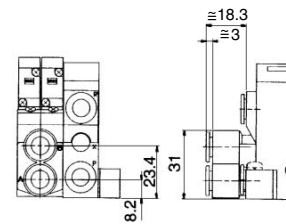
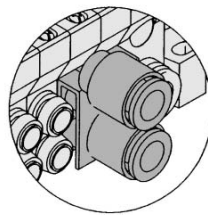

Silencer (For EXH port)

This silencer is to be inserted into the EXH port (One-touch fittings) of the common exhaust type

* When mounting elbow fittings assembly (VVQ1000-F-L□) on the edge of manifold station, select a silencer, AN203-KM8.

Silencer (AN200-KM8) is interfered with fittings.

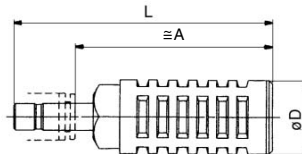

Dimensions

Series	Applicable fittings size ød	Model	A	L	D	Effective area (mm ²)	Noise reduction (dB)
VQ1000	8	AN200-KM8	59	78	22	20	30
		AN203-KM8	32	51	16	14	25*

Regulator unit

VVQ1000-AR-1

The regulator controls the SUP air pressure in a manifold. Supply air from D side SUP port is regulated. SUP port on U side is plugged.

Specifications

Maximum operating pressure	0.8 MPa
Set pressure range	0.05 to 0.7 MPa
Ambient and fluid temp.	5 to 50°C
Fluid	Air
Cracking pressure	0.02 MPa
Structure	Relieving type

Pressure gauge G27-10-01

Pressure control screw

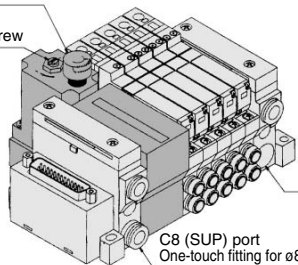

• How to Order

Indicate an option symbol "-G*" for the manifold no. and be sure to specify the mounting position and number of stations by means of the manifold specification form. One unit is counted as one station and occupies a space for three stations, therefore, pay attention to the manifold size.

The regulator valve unit, to which no wire is connected, valves can be mounted up to the standard max. number of stations of each kit.

How to order manifold

VV5Q11-14C6FUO-DG2

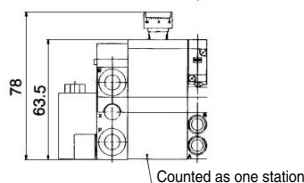
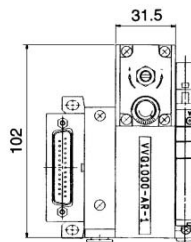
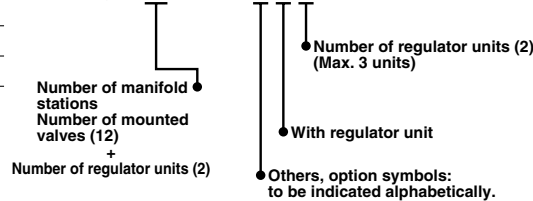

Flow Characteristics

Conditions: Inlet pressure 0.7 MPa

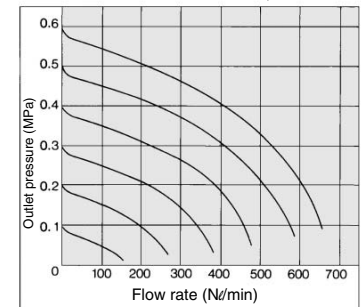

Pressure characteristics

Conditions (Initial setting) Inlet pressure 0.7 MPa
Outlet pressure 0.2 MPa

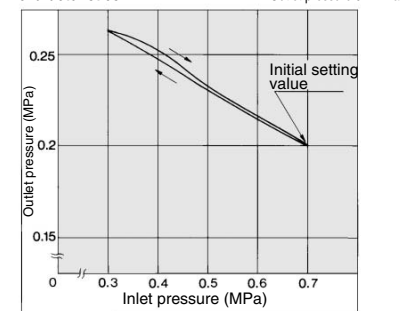

⚠ Caution

• Pressure setting

Check the supply pressure and then turn the pressure control screw to set the secondary pressure. Turning the screw clockwise will increase the secondary pressure while turning it counterclockwise decrease the pressure. (Set the pressure by turning the screw in the increase direction.)

• Installation

Since some level of the actuator's operational frequency may lead to a sharp pressure change, pay attention to the pressure gauge durability.

Double check block (Separated type): For VQ1000 VQ1000-FPG-□□

It is used on the outlet side piping to keep the cylinder in the intermediate position for a long time. Combining the double check block with a built-in pilot type double check valve and a 3 position exhaust center solenoid valve will enable the cylinder to stop in the middle or maintain its position for a long time.

The combination with a 2 position single/double solenoid valve will permit this block to be used for preventing the dropping at the cylinder stroke end when the SUP residual pressure is released.

Specifications

Max. operating pressure	0.8 MPa
Min. operating pressure	0.15 MPa
Ambient and fluid temp.	-5 to 50°C
Flow characteristics: C	0.60 dm ³ /(s·bar)
Max. operating frequency	180 CPM

Note) Based on JIS B 8375-1981 (Supply pressure: 0.5 MPa)

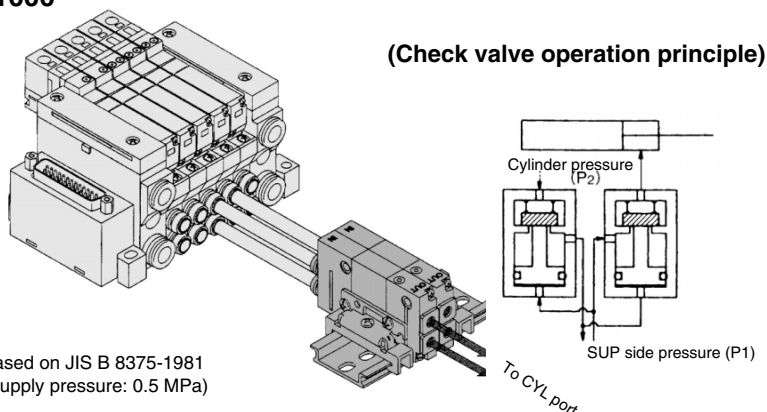

VVQ1000-FPG-02 1 set
* VQ1000-FPG-C6M5-D 2 pcs.

- VQC
- SQ
- VQ0
- VQ4
- VQ5
- QZ
- QD

Dimensions

Single unit

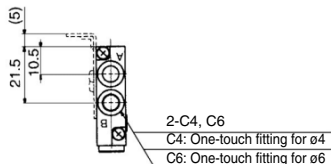

Manifold

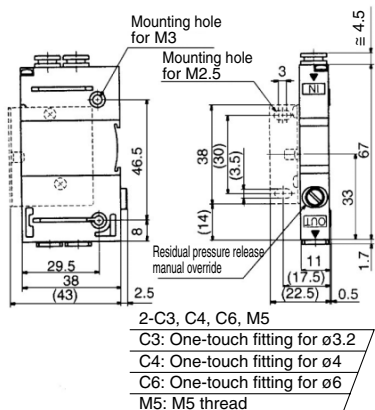
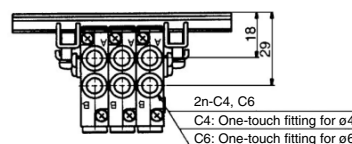

Dimensions Formula L1 = 11n + 20 n: Station (Maximum 24)

L _n	1	2	3	4	5	6	7	8	9	10	11	12
L1	31	42	53	64	75	86	97	108	119	130	141	152
L2	50	62.5	75	87.5	100	112.5	125	137.5	150	162.5	175	
L3	60.5	73	85.5	98	110.5	123	135.5	148	160.5	173	185.5	

L _n	13	14	15	16	17	18	19	20	21	22	23	24
L1	163	174	185	196	207	218	229	240	251	262	273	284
L2	187.5	187.5	200	212.5	225	237.5	250	250	262.5	275	287.5	300
L3	198	198	210.5	223	235.5	248	260.5	260.5	273	285.5	298	310.5

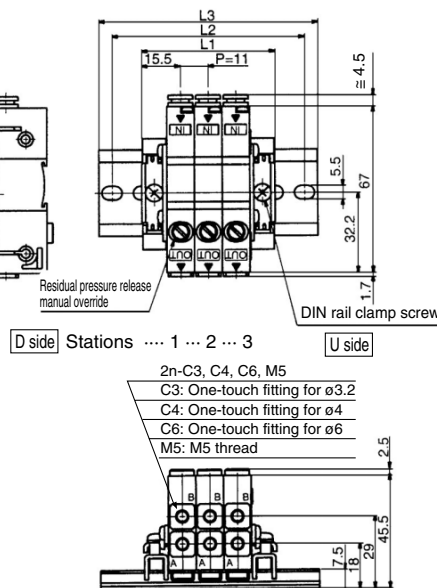

How to Order

Double check block

VQ1000-FPG-**C4** **M5** **F**

IN side port size

C4	With One-touch fitting for ø4
C6	With One-touch fitting for ø6

OUT side port size

M5	M5 thread
C3	One-touch fitting for ø3.2
C4	One-touch fitting for ø4
C6	One-touch fitting for ø6

Option

Nil	None
F	With bracket
D	DIN rail mounting style (For manifold)
N	Name plate

Note) When two or more symbols are specified, indicate them alphabetically. Example) -DN

Manifold

VVQ1000-FPG-**06**

Stations

01	1 station
⋮	⋮
16	16 stations

<Example>

VVQ1000-FPG-06-6 types of manifold
*VQ1000-FPG-C4M5-D, 3 sets } Double Check block
*VQ1000-FPG-C6M5-D, 3 sets }

Bracket Assembly

Part no.	Tightening torque
VQ1000-FPG-FB	0.22 to 0.25 N·m

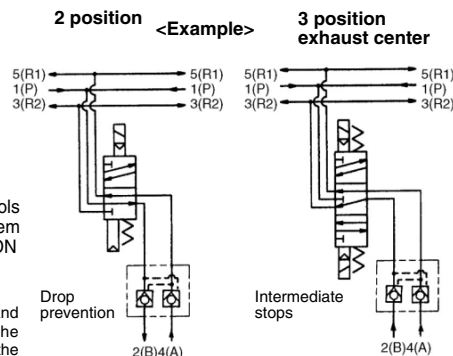

Caution

- Air leakage from the pipe between the valve and cylinder or from the fittings will prevent the cylinder from stopping for a long time. Check the leakage using neutral household detergent, such as dish washing soap. Also check the cylinder's tube gasket, piston packing and rod packing for air leakage.
- Since One-touch fittings allow slight air leakage, screw piping (with M5 thread) is recommended when stopping the cylinder in the middle for a long time.
- Combining double check block with 3 position closed center or pressure center solenoid valve will not work.
- M5 fitting assembly is attached, not incorporated into the double check block. After screwing in the M5 fittings, mount the assembly on the double check block. (Tightening torque: 0.8 to 1.2 N·m)
- If the exhaust of the double check block is throttled too much, the cylinder may not operate properly and may not stop intermediately.
- Set the cylinder load so that the cylinder pressure will be within two times that of the supply pressure.

Manifold Option/Vacuum Ejector Unit: VQ1000

A vacuum ejector unit can be mounted on the manifold base for a solenoid valve. Instead of mounting the valve and vacuum ejector unit separately, this option reduces piping, wiring and creates additional space savings.

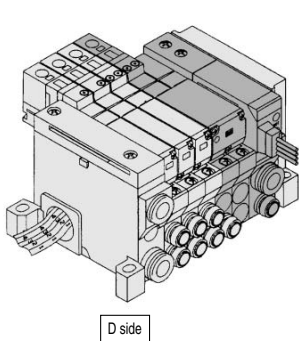

- Note 1) SUP and EXH ports on the vacuum ejector unit manifold base are arranged on D side alone. The end plate on the U side is the same as that used in the L kit.
- Note 2) Individual piping is provided for the supply and exhaust ports of the vacuum ejector unit.
- Note 3) The manifold with an vacuum ejector unit type is mounted from the U side.
- Note 4) One vacuum ejector unit corresponds to one station.
* Specify the position of stations on the manifold specification sheet.

Specifications

Unit no.	VVQ1000-J□-□□□-A	VVQ1000-J□-□□□-B
Nozzle diameter (mm)	0.7	1.0
Max. suction flow rate N (ℓ/min)	11	20
Max. vacuum pressure	-630 mmHg	
Max. operating pressure	0.8 MPa	
Standard supply pressure	0.5 MPa	
Operating temperature	5 to 50°C	

Maximum Number of Ejector Units

(Max. number of ejector units is subject to the number of valve stations.)

Max. number of ejector units	Max. number of mounted valves		
	F, P, T kit	S, G, J kit	L kit
1	11(20)	7(14)	7
2	10(16)	6(12)	6
3	9(12)	5(10)	5
4	8(8)	4(8)	—
5	4(4)	3(4)	—

Note) The max. number of mounted valves applies to double wiring. Parenthesized numbers apply to single wiring. Please contact SMC for conditions other than the above or mixed wiring.

Dimensions

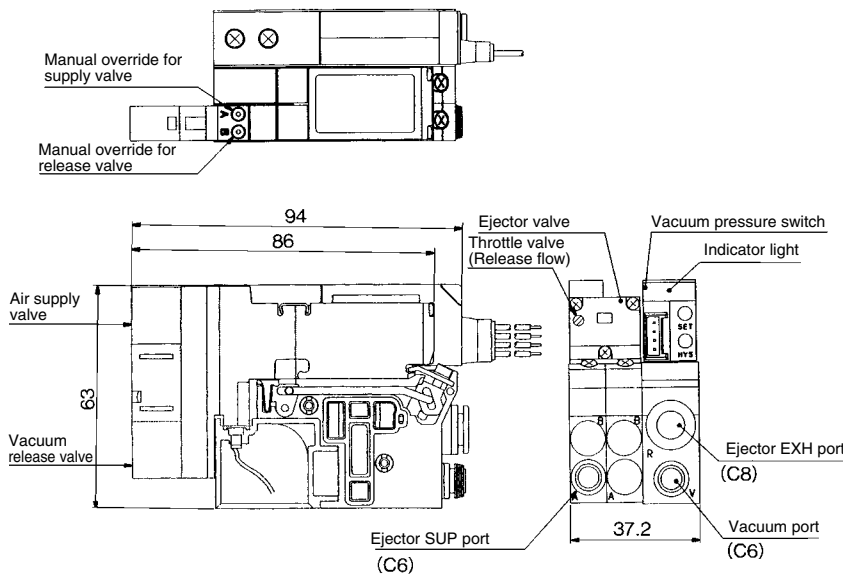

How to Order

VV5Q11-05C6FUO-J **P** **1** **S**

Vacuum switch

Nil	None
P	With

Others, option symbols: to be indicated alphabetically.

Ejection unit
1 to 5

Example) VV5Q11-05C6FUO-JP1...1 set—Manifold part no.

- *VQ1100-5 2 sets—Valve part no. (Stations 1 to 2)
- *VQ1200-5 2 sets—Valve part no. (Stations 3 to 4)
- *VVQ1000-J1-5-A ... 1 set—Ejector valve part no.
- *ZSE1-00-15-CL 1 set—Vacuum switch part no.

- Note 1) Count one ejector unit as one manifold station.
- Note 2) The ejector unit is mounted next to the U-side end plate.
- Note 3) The U-side end plate is used exclusively for ejector units. (Without P and R port)
- Note 4) The dimension of manifold with an ejector unit is different from the standard dimension. See the formula for calculating the dimensions for each kit.

How to Order Vacuum Ejector Valves

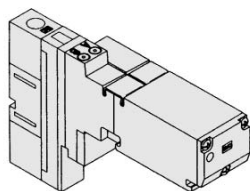

VVQ1000 – J 1 – 5 H C – A

Manifold
1 Plug-in unit

Coil voltage

1	100 VAC (50/60 Hz)	5	24 VDC
2	200 VAC (50/60 Hz)	6	12 VDC
3	110 VAC (50/60 Hz)	9	Others
4	220 VAC (50/60 Hz)		

Function

Symbol	Specifications	DC	AC
Nil	Standard type	(1.0W) ○	○ ⁽¹⁾
H	High pressure type	(1.5 W) ○	—
Y	Low wattage type	(0.5W) ○	—
N	Negative COM	○	—

Specifications

Symbol	Nozzle diameter	Vacuum release valve
A	ø0.7	With
B	ø1.0	

Manual override

Symbol	Specifications
Nil	Non-locking push type
B	Locking type (Tool required)
C	Locking type (Manual)

Note 1) For power consumption of AC type, refer to page 2-4-129.
Note 2) When two or more symbols are specified, indicate them alphabetically.

How to Order Vacuum Pressure Switches

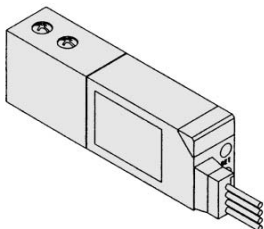

ZSE1 – 00 – 15 – CL

Switch/Voltage (Solid state: 12 to 24 VDC)

14	NPN/1 setting, 3 revolution adjustment
15	NPN/1 setting, 200° adjustment
16	NPN/2 setting, 3 revolution adjustment
17	NPN/2 setting, 200° adjustment
18	NPN/1 setting, 3 revolution adjustment, analog
19	NPN/1 setting, 200° adjustment, analog

Wiring specifications

Nil	Grommet type, Lead wire length 0.6 m
L	Grommet type, Lead wire length 3 m
C	Connector type, Lead wire length 0.6 m
CL	Connector type, Lead wire length 3 m
CN	Without connector ^{Note)}

Note) When ordering the switch with 5 m lead wire length, order separately the switch without connector and the connector. (Refer to below.) Besides, as for details, refer to the Vacuum Equipment catalog.

How to order connectors

- Without lead wire (Connector 1 pc., Socket 4 pcs.) ZS-20-A
- With lead wire ZS-20-5A-50

Lead wire length

Nil	0.6 m
30	3 m
50	5 m

(The flow characteristics are for the supply pressure of 0.5 MPa.)

Flow/Exhaust Characteristics of Ejector Unit

Nozzle Diameter ø0.7
Exhaust Characteristics

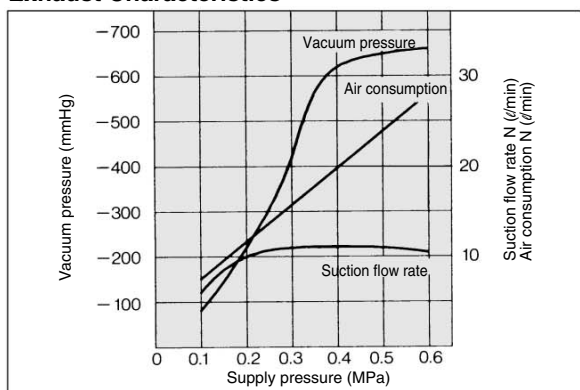

Flow Characteristics

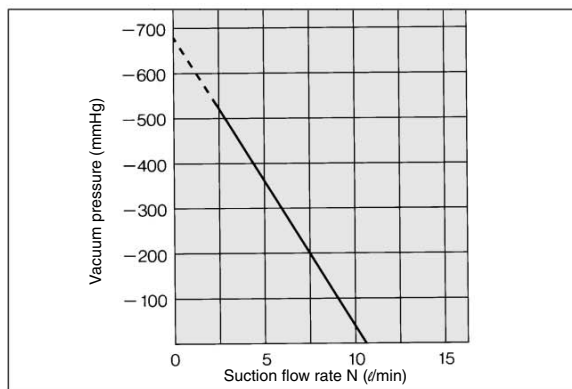

Nozzle Diameter ø1.0

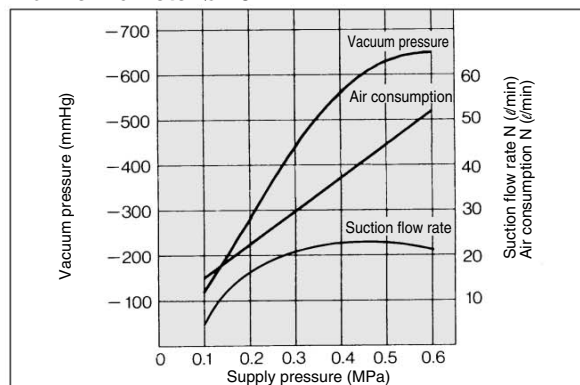

Flow Characteristics

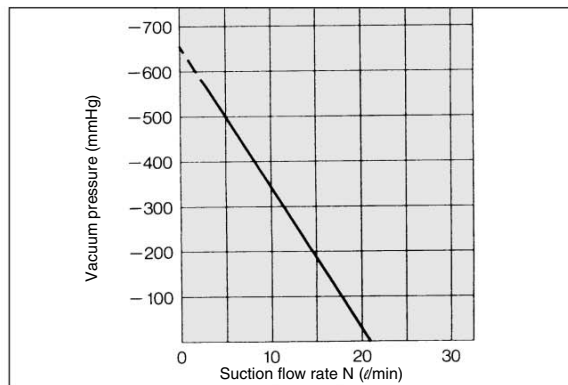

⚠ Precautions 1

Be sure to read before handling. For Safety Instructions and Solenoid Valve Precautions, refer to page 2-9-2.

Light/Surge Voltage Suppressor

⚠ Caution

The lighting positions are concentrated on one side for both single solenoid type and double solenoid type. In the double solenoid type, A side and B side energization are indicated by two colors which match the colors of the manual overrides.

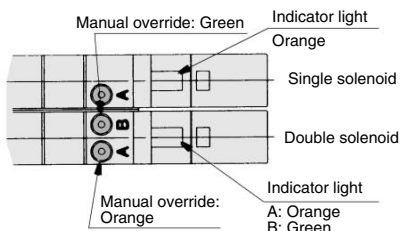

(DWG shows a VQ1000 case.)

DC circuit diagram Single solenoid

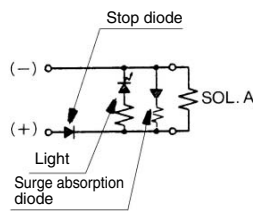

Note)
A side energization: A light (orange) illuminates.
B side energization: B light (green) illuminates.

Double solenoid

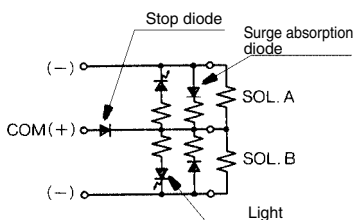

With wrong wiring preventing ability (stop diode).
Equipped with a surge absorption (surge absorption diode) mechanism.

Manual Override

⚠ Warning

Without an electric signal for the solenoid valve the manual override is used for switching the main valve.

Push type is standard. (Tool required)

Option: Locking type (Tool required/Manual)

■ Push type (Tool required)

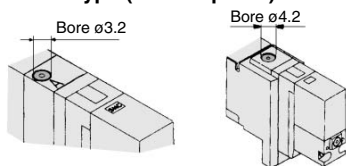

Push down on the manual override button with a small screwdriver until it stops. Release the screwdriver and the manual override will return.

VQ1000

VQ2000

■ Locking type (Tool required) <Option>

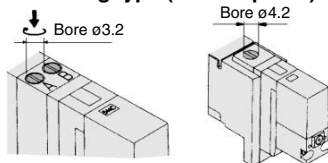

Push down on the manual override button with a small screwdriver or with your fingers until it stops. Turn clockwise by 90° to lock it. Turn it counterclockwise to release it.

VQ1000

VQ2000

■ Locking type (Manual) <Option>

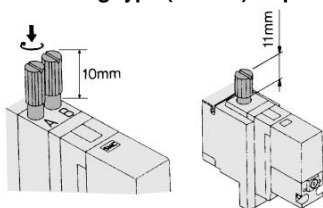

Push down on the manual override button with a small screwdriver or with your fingers until it stops. Turn clockwise by 90° to lock it. Turn it counterclockwise to release it.

VQ1000

VQ2000

⚠ Caution

Do not apply excessive torque when turning the locking type manual override. (0.1 N·m or less)

How to Mount/Remove Solenoid Valve

⚠ Caution

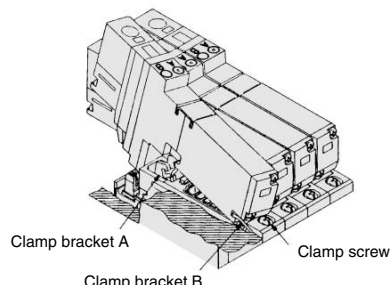

Removing

1. Loosen the clamp screw until it turns freely. (The screw is captive.)
2. Lift the coil side of the valve body while pressing down slightly on the screw head and remove it from the clamp bracket B. When the screw head cannot be pressed easily, gently press the area near the manual override of the valve.

Mounting

1. Press down on the clamp screw. → Clamp bracket A opens. Diagonally insert the hook on the valve end plate side into clamp B.
2. Press the valve body downward. (When the screw is released, it will be locked by clamp bracket A.)
3. Tighten the clamp screw. (Proper tightening torque: VQ1000, 0.25 to 0.35 N·m; VQ2000, 0.5 to 0.7 N·m.)

⚠ Caution

Dust on the sealing surface of the gasket or solenoid valve can cause air leakage.

Replacement of Cylinder Port Fittings

⚠ Caution

The cylinder port fittings are a cassette for easy replacement. The fittings are blocked by a clip inserted from the top of manifold. Remove the clip with a screwdriver to remove fittings.

For replacement, insert the fitting assembly until it strikes against the inside wall and then reinsert the clip to the specified position.

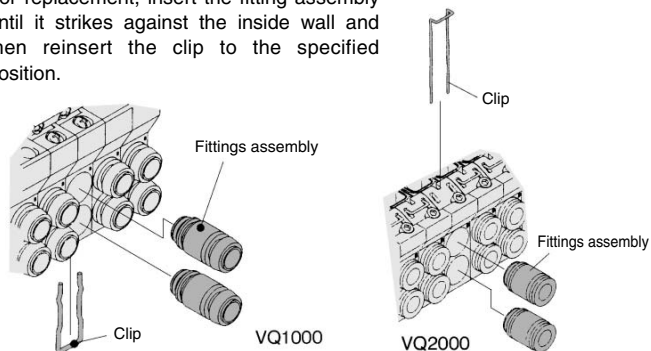

Applicable tubing O.D.	Fitting assembly part no.	
	VQ1000	VQ2000
Applicable tubing ø3.2	VVQ1000-50A-C3	—
Applicable tubing ø4	VVQ1000-50A-C4	VVQ1000-51A-C4
Applicable tubing ø6	VVQ1000-50A-C6	VVQ1000-51A-C6
Applicable tubing ø8	—	VVQ1000-51A-C8
M5	VVQ1000-50A-M5	—

* Refer to "Option" on pages 2-4-172 to 2-4-173 for other types of fittings.

⚠ Caution

1. Use caution that O-rings must be free from scratches and dust. Otherwise, air leakage may result.
2. After screwing in the fittings, mount the M5 fitting assembly on the manifold base. (Tightening torque: 0.8 to 1.2 N·m)
3. Purchasing order is available in units of 10 pieces.

⚠ Precautions 2

Be sure to read before handling. For Safety Instructions and Solenoid Valve Precautions, refer to page 2-9-2.

Mounting/Removing from the DIN Rail

⚠ Caution

Removing

1. Loosen the clamp screw on side (a) of the end plate on both sides.
2. Lift side (a) of the manifold base and slide the end plate in the direction of (2) shown in the figure to remove.

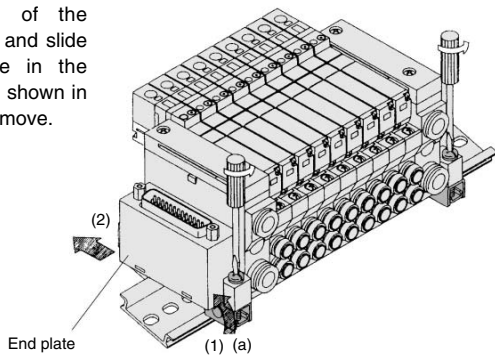

Mounting

1. Hook side (b) of the manifold base on the DIN rail.
2. Press down side (a) and mount the end plate on the DIN rail.
Tighten the clamp screw on side (a) of the end plate.
The proper tightening torque for screws is 0.4 to 0.6 N·m.

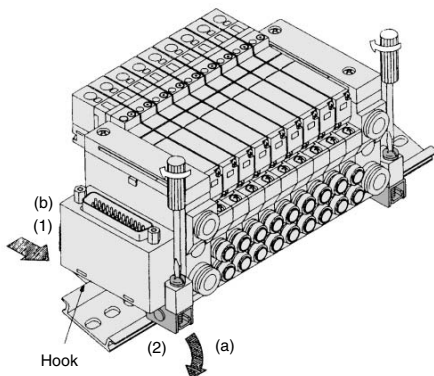

Enclosure IP65

⚠ Caution

Wires, cables, connectors, etc. used for models conforming to IP65 should also have enclosures equivalent to or of stricter than IP65.

Built-in Silencer Replacement Element

⚠ Caution

A silencer element is incorporated in the end plate on both sides of the A dirty and choked element may reduce cylinder speed or cause malfunction. Clean or replace the dirty element.

Element Part No.

Type	Element part no.	
	VQ1000	VQ2000
Built-in silencer, direct exhaust	VVQ1000-82A-1	VVQ2000-82A-1

* The minimum order quantity is 10 pcs.

Remove the cover from the top of the end plate and remove the old element with a screwdriver, etc.

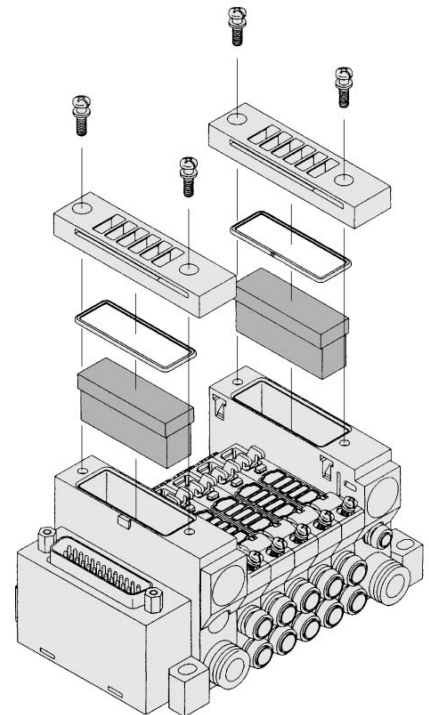

How to Calculate the Flow Rate

For obtaining the flow rate, refer to pages 2-1-8 to 2-1-11.

External Pilot Specifications

When the supply air pressure is lower than the required minimum operating pressure (0.1 to 0.2 MPa) for the solenoid valve (or when the valve is used for vacuum), specify an external pilot model. Order a manifold or valve by suffixing the external pilot specification, "R".

The X-port of the manifold base is equipped with One-touch fittings for external pilot.

VQ1000: C4 (One-touch fitting for ø4)

VQ2000: C6 (One-touch fitting for ø6)

How to order manifold

VV5Q11-08C6FU1-R S

Others, option symbols:
to be indicated alphabetically.

How to order valves

VQ1100 R - 5

External pilot specifications

Note 1) When low wattage type is also desired, specify as "RY".

Note 2) In this valve pilot exhaust is connected to the EA passage of the manifold. Therefore, it is not possible to supply air from EXH port, nor vacuum from ports other than SUP port.

Inch-size One-touch Fittings

The valve with inch-size One-touch fittings is shown below.

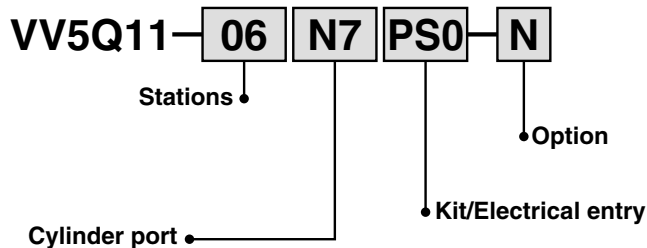

Symbol	N1	N3	N7	N9	M5T	NM
Applicable tubing O.D. (Inch)	ø 1/8"	ø 5/32"	ø 1/4"	ø 5/16"	10-32UNF (M5 thread)	Mixed
4(A), 2(B) port	VQ1000	●	●	—	●	●
	VQ2000	—	●	●	—	●

Note) When inch-size fittings are selected for the cylinder port, use inch size fittings for both P and R port.

1(P), 3(R) port size
 VQ1000 ø5/16" (N9)
 VQ2000 ø3/8" (N11)

VQC

SQ

VQ0

VQ4

VQ5

VQZ

VQD

Series VQ1000/2000

Option

DIN Rail Mounting

Each manifold can be mounted on a DIN rail. Order it by indicating a DIN rail mounting option symbol, "-D". In this case, a DIN rail which is approx. 30 mm longer than the manifold with the specified number of stations is attached.

- **When DIN rail is unnecessary**
(DIN rail mounting brackets only are attached.)
Indicate the option symbol, "-DO", for the manifold no.

Example)

VV5Q11-08C6FU1-D0S

Others, option symbols:
to be indicated alphabetically.

- **When using DIN rail longer than the manifold with specified number of stations**
Clearly indicate the necessary number of stations next to the option symbol "-D" for the manifold no.

Example)

VV5Q11-08C6FU1-D09S

DIN rail for 9 stations

Others, option symbols:
to be indicated alphabetically.

- **When changing the manifold style into a DIN rail mounting style.**
Order brackets for mounting a DIN rail. (Refer to "Option" on pages 2-4-168 and 2-4-173.)

No. VVQ1000-57A (For VQ1000)
VVQ2000-57A (For VQ2000)
2 pcs. per one set.

- **When ordering DIN rail only**
DIN rail no.: AXT100-DR-□

As for □, specify the number from the DIN rail table.
For L dimension, refer to the dimensions of each kit.

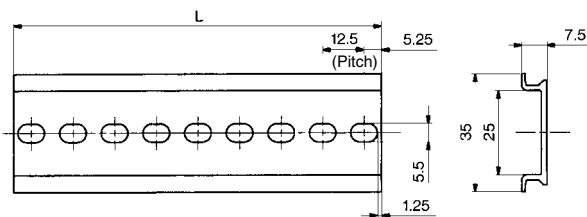

L Dimension

$$L = 12.5 \times n + 10.5$$

No.	1	2	3	4	5	6	7	8	9	10
L dimension	23	35.5	48	60.5	73	85.5	98	110.5	123	135.5
No.	11	12	13	14	15	16	17	18	19	20
L dimension	148	160.5	173	185.5	198	210.5	223	235.5	248	260.5
No.	21	22	23	24	25	26	27	28	29	30
L dimension	273	285.5	298	310.5	323	335.5	348	360.5	373	385.5
No.	31	32	33	34	35	36	37	38	39	40
L dimension	398	410.5	423	435.5	448	460.5	473	485.5	498	510.5

Exploded View of Manifold

Exploded view: VQ1000/Plug-in Unit

(F, P, J, L, Skit)

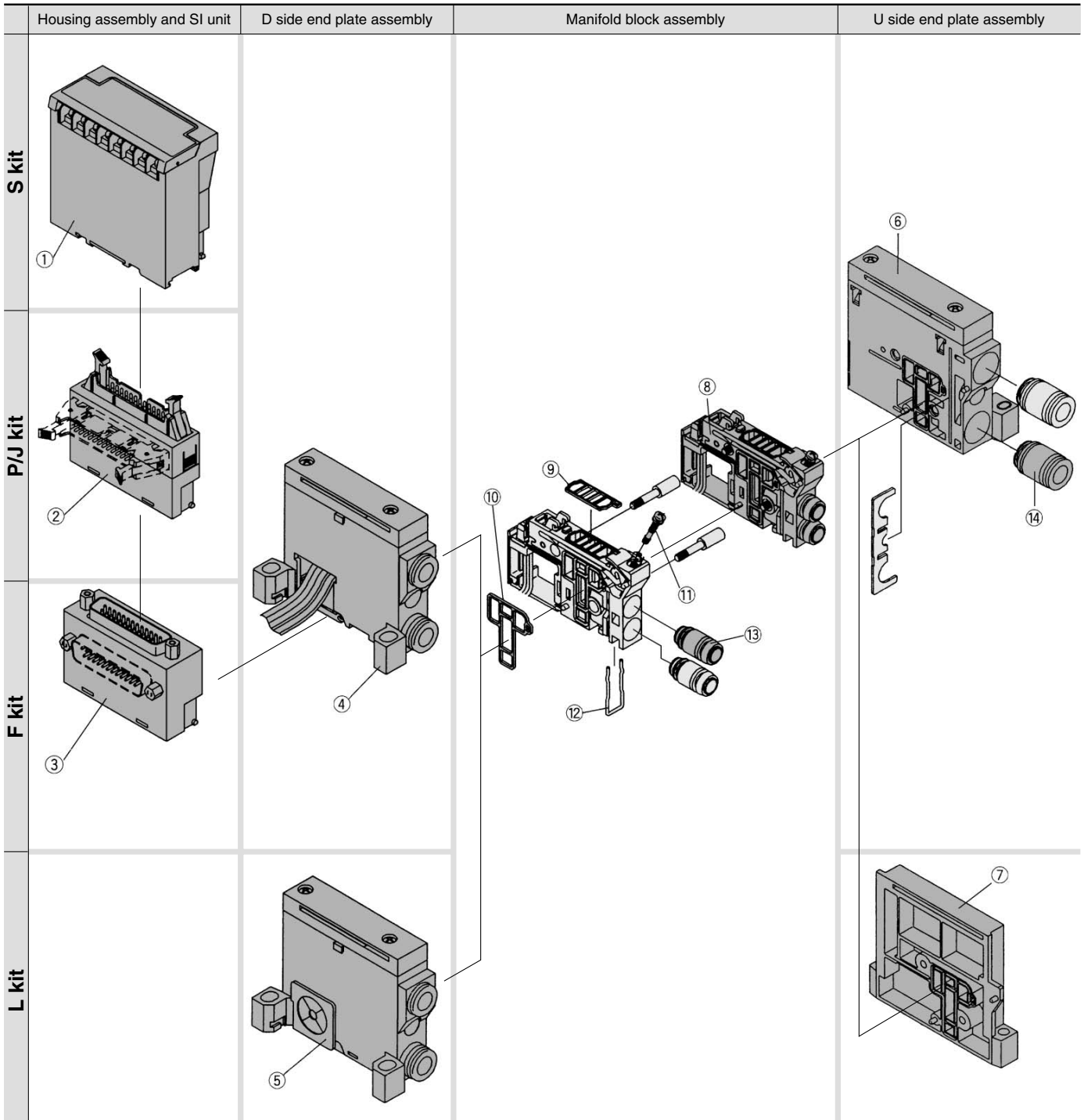

<Housing Assembly and SI Unit>

Housing assembly and SI unit no.

No.	Manifold	Part no.	Description
①	(SA kit)	EX320-S001(-XP) ⁽²⁾	General type SI unit (Series EX300)
	(SB kit)	EX120-SMB1(-XP) ⁽²⁾	SI unit for MELSECNET/MINI-S3 Data Link System (Mitsubishi Electric Corporation)
	(SC kit)	EX120-STA1(-XP) ⁽²⁾	SI unit for SYSBUS Wire System (OMRON Corporation)
	(SD kit)	EX120-SSH1(-XP) ⁽²⁾	SI unit for Satellite I/O Link System (SHARP Corporation)
	(SE kit)	EX120-SPA1	SI unit for MEWNET-F System (Matsushita Electric Works, Ltd.)
	(SF1kit)	EX120-SUW1(-XP) ⁽²⁾	SI unit for 16 point Uni-wire System (NKE Corporation)
	(SG kit)	EX120-SAB1(-XP) ⁽²⁾	SI unit for Allen Bradley Remote I/O (RIO) System (Rockwell Automation, Inc.)
	(SH kit)	EX120-SUH1(-XP) ⁽²⁾	SI unit for 16 point Uni-wire H System (NKE Corporation)
	(SJ1 kit)	EX120-SSL1(-XP) ⁽²⁾	16 point S-LINK System (SUNX Corporation)
	(SJ2 kit)	EX120-SSL2(-XP) ⁽²⁾	8 point S-LINK System (SUNX Corporation)
	(SK kit)	EX120-SFU1(-XP) ⁽²⁾	T-LINK Mini System (Fuji Electric Co.,Ltd.)
	(SQ kit)	EX120-SDN1	DeviceNet, CompoBus/D (OMRON Corporation)
	(SR1 kit)	EX120-SCS1(-XP) ⁽²⁾	OMRON Corporation: CompoBus/S (16 output points)
	(SR2 kit)	EX120-SCS2(-XP) ⁽²⁾	OMRON Corporation: CompoBus/S (8 output points)
	(SV kit)	EX120-SMJ1(-XP) ⁽²⁾	Mitsubishi Electric Corporation: CC-LINK System
②	P $\frac{1}{2}$ kit	AXT100-1-P $\frac{1}{2}$ □ ⁽¹⁾	Flat cable housing assembly □ = Number of pins: 26, 20, 16, 10
	J $\frac{1}{2}$ kit	AXT100-1-J $\frac{1}{2}$ □ ⁽¹⁾	Flat cable housing assembly
③	F $\frac{1}{2}$ kit	AXT100-1-F $\frac{1}{2}$ □ ⁽¹⁾	D-sub connector housing assembly □ = Number of pins: 25, 15

Note 1) Top (vertical) entry connector for FU, PU and JU while side (horizontal) entry connector for FS, JS and PS.

Note 2) Enter suffix "-XP" at the end of the part number for dust proof type SI unit.

VQC

SQ

VQ0

VQ4

VQ5

VQZ

VQD

<D Side End Plate Assembly>

④⑤ D side end plate assembly no.

VVQ1000-3A-1-□-□

Electrical entry Option

F	For F kit	Nil	Common exhaust type
P	For P kit	R ⁽¹⁾	External pilot
J	For J kit	S ⁽¹⁾	Built-in silencer, direct exhaust
L	For L kit		
S	For S kit		

Note 1) When both options are specified, indicate as RS.
 Note 2) The housing assembly and SI unit of F/P/S kit are not included.
 Separately place an order for ①, ②, and ③.

<U Side End Plate Assembly>

⑥ U side end plate assembly no. (For F, P, J, S kit)

VVQ1000-2A-1-□

Option

Nil	Common exhaust type
R	External pilot
S	Built-in silencer, direct exhaust



Note) The ⑭' s fitting assembly is included.

<Manifold Block Assembly>

⑧ Manifold block assembly no. Tie-rod (2 pcs.) and lead wire assembly for extensions are attached

VVQ1000-1A-□

Electrical entry Port size

F1	F kit for 2 to 12 stations/Double wiring	C3	With One-touch fitting for ø3.2
F2	F kit for 13 to 24 stations/Double wiring	C4	With One-touch fitting for ø4
F3	F kit for 2 to 24 stations/Single wiring	C6	With One-touch fitting for ø6
P1	P, J, S kit for 2 to 12 stations/Double wiring	M5	M5 thread
P2	P, J, S kit for 13 to 24 stations/Double wiring		
P3	P, J, S kit for 2 to 24 stations/Single wiring		
L0 □	L0 kit □Stations (1 to 8)		
L1 □	L1 kit □Stations (1 to 8)		
L2 □	L2 kit □Stations (1 to 8)		

⑦ U side end plate assembly no. (For L kit)

VVQ1000-2A-1-L

<Replacement Parts for Manifold Block>

Replacement Parts

No.	Part no.	Description	Material	Number
⑨	VVQ1000-80A-1	Gasket	NBR	12
⑩	VVQ1000-80A-2	Packing	NBR	12
⑪	VVQ1000-80A-3	Clamp screw	Carbon steel	12
⑫	VVQ1000-80A-4	Clip	Stainless steel	12

Note) A set of parts containing 12 pcs. each is enclosed.

<Fitting Assembly>

⑬ Fitting assembly part no. (For cylinder port)

VVQ1000-50A-□

Port size



Note) Purchasing order is available in units of 10 pieces.

C3	Applicable tubing ø3.2
C4	Applicable tubing ø4
C6	Applicable tubing ø6
M5	M5 thread

⑭ Fitting assembly part no. (For P, R port)

VVQ1000-51A-C8

Applicable tubing ø8



Note) Purchasing order is available in units of 10 pieces.