

# Series VQ1000 Base Mounted Plug-in Unit

## How to Order Manifold

VV5Q 1 1-08 C6 F U1

Series  
1 VQ1000

Manifold  
1 Plug-in unit

Stations  
01 1 station  
:  
:

The maximum and minimum number of stations are varied depending on kit. (Refer to the table below.)

### Option

Symbol	Option
Nil	None
2	200/220 VAC models (Applicable to F and L kits)
B	With back pressure check valve <sup>(2)</sup>
D	DIN rail mounting
G1	1 set of regulator unit <sup>(3)</sup>
G2	2 sets of regulator unit <sup>(3)</sup>
G3	3 sets of regulator unit <sup>(3)</sup>
J	With vacuum ejector unit <sup>(4)</sup>
K	Special wiring specifications (Not double wiring) <sup>(5)</sup>
N	With name plate
R	External pilot <sup>(6)</sup>
S	Built-in silencer, direct exhaust

Note 1) When two or more symbols are specified, indicate them alphabetically. Example) -BRS

Note 2) Models with a suffix "-B" have check valves for prevention of back pressure at all manifold stations. If not all stations need this check valve, specify the stations where check valves are installed by using the manifold specification sheet.

Note 3) Specify the mounting position in the manifold specification sheet.

Note 4) Refer to page 2-4-170 for the details of ejector mounted styles. A combination of "J" and "N" is unavailable.

Note 5) Specify the wiring by means of the manifold specification sheet. (Except L kit)

Note 6) Indicate "R" for the valve with external pilot.

### Cylinder port

Symbol	Port size	Symbol	Port size
C3	With One-touch fitting for ø3.2	L6	W/ elbow One-touch fitting ø6 for top piping
C4	With One-touch fitting for ø4	L5	Elbow M5 thread for top piping
C6	With One-touch fitting for ø6	B3	W/ elbow One-touch fitting ø3.2 for bottom piping
M5	M5 thread	B4	W/ elbow One-touch fitting ø4 for bottom piping
CM	With mixed size/with port plug <sup>(1)</sup>	B6	W/ elbow One-touch fitting ø6 for bottom piping
L3	W/ elbow One-touch fitting ø3.2 for top piping	B5	Elbow M5 thread for bottom piping
L4	W/ elbow One-touch fitting ø4 for top piping	LM	Mixed size for elbow piping

Note 1) Specify "Mixed size/with port plug" in the manifold specification sheet.  
Note 2) Inch-size One-touch fittings are also available. For details, refer to page 2-4-179.  
Note 3) M5 fittings for M5 thread are attached without being incorporated.



Simple specials are available with SMC Simple Specials System. For details about applicable models, please contact SMC.

### Kit/Electrical entry/Cable length

F kit (D-sub connector)		P kit (Flat ribbon cable connector)		J kit (Flat ribbon cable connector (20P))		G Kit (Flat ribbon cable connector with power supply terminal block)																																																													
<p>Note 1) 25P</p>		<p>Note 1) 26P</p>		<p>Note 1) 26P</p>		<p>The valve is equipped with Compatible only with 24 VDC valves. Order separately SI unit made by OMRON Corp.</p>																																																													
<p>Connector entry direction</p> <table border="1"> <tr> <th>Top entry</th> <th>Side entry</th> </tr> <tr> <td>U0</td> <td>S0</td> </tr> <tr> <td>U1</td> <td>S1</td> </tr> <tr> <td>U2</td> <td>S2</td> </tr> <tr> <td>U3</td> <td>S3</td> </tr> </table>		Top entry	Side entry	U0	S0	U1	S1	U2	S2	U3	S3	<p>Connector entry direction</p> <table border="1"> <tr> <th>Top entry</th> <th>Side entry</th> </tr> <tr> <td>U0</td> <td>S0</td> </tr> <tr> <td>U1</td> <td>S1</td> </tr> <tr> <td>U2</td> <td>S2</td> </tr> <tr> <td>U3</td> <td>S3</td> </tr> </table>		Top entry	Side entry	U0	S0	U1	S1	U2	S2	U3	S3	<p>Connector entry direction</p> <table border="1"> <tr> <th>Top entry</th> <th>Side entry</th> </tr> <tr> <td>U0</td> <td>S0</td> </tr> <tr> <td>U1</td> <td>S1</td> </tr> <tr> <td>U2</td> <td>S2</td> </tr> <tr> <td>U3</td> <td>S3</td> </tr> </table>		Top entry	Side entry	U0	S0	U1	S1	U2	S2	U3	S3	<p>Connector entry direction</p> <table border="1"> <tr> <th>Top entry</th> <th>Side entry</th> </tr> <tr> <td>U0</td> <td>S0</td> </tr> <tr> <td>U1</td> <td>S1</td> </tr> <tr> <td>U2</td> <td>S2</td> </tr> <tr> <td>U3</td> <td>S3</td> </tr> </table>		Top entry	Side entry	U0	S0	U1	S1	U2	S2	U3	S3																				
Top entry	Side entry																																																																		
U0	S0																																																																		
U1	S1																																																																		
U2	S2																																																																		
U3	S3																																																																		
Top entry	Side entry																																																																		
U0	S0																																																																		
U1	S1																																																																		
U2	S2																																																																		
U3	S3																																																																		
Top entry	Side entry																																																																		
U0	S0																																																																		
U1	S1																																																																		
U2	S2																																																																		
U3	S3																																																																		
Top entry	Side entry																																																																		
U0	S0																																																																		
U1	S1																																																																		
U2	S2																																																																		
U3	S3																																																																		
<p>P. 2-4-130</p>		<p>P. 2-4-134</p>		<p>P. 2-4-138</p>		<p>P. 2-4-142</p>																																																													
<table border="1"> <tr> <th>Kit</th> <th>Without cable</th> <th>(2)</th> </tr> <tr> <td>U0</td> <td>Without cable</td> <td>2 to 24 stations</td> </tr> <tr> <td>U1</td> <td>With cable (1.5 m)</td> <td></td> </tr> <tr> <td>U2</td> <td>With cable (3 m)</td> <td></td> </tr> <tr> <td>U3</td> <td>With cable (5 m)</td> <td></td> </tr> </table>		Kit	Without cable	(2)	U0	Without cable	2 to 24 stations	U1	With cable (1.5 m)		U2	With cable (3 m)		U3	With cable (5 m)		<table border="1"> <tr> <th>Kit</th> <th>Without cable</th> <th>(2)</th> </tr> <tr> <td>U0</td> <td>Without cable</td> <td>2 to 24 stations</td> </tr> <tr> <td>U1</td> <td>With cable (1.5 m)</td> <td></td> </tr> <tr> <td>U2</td> <td>With cable (3 m)</td> <td></td> </tr> <tr> <td>U3</td> <td>With cable (5 m)</td> <td></td> </tr> </table>		Kit	Without cable	(2)	U0	Without cable	2 to 24 stations	U1	With cable (1.5 m)		U2	With cable (3 m)		U3	With cable (5 m)		<table border="1"> <tr> <th>Kit</th> <th>Without cable</th> <th>(2)</th> </tr> <tr> <td>U0</td> <td>Without cable</td> <td>2 to 16 stations</td> </tr> <tr> <td>U1</td> <td>With cable (1.5 m)</td> <td></td> </tr> <tr> <td>U2</td> <td>With cable (3 m)</td> <td></td> </tr> <tr> <td>U3</td> <td>With cable (5 m)</td> <td></td> </tr> </table>		Kit	Without cable	(2)	U0	Without cable	2 to 16 stations	U1	With cable (1.5 m)		U2	With cable (3 m)		U3	With cable (5 m)		<table border="1"> <tr> <th>Kit</th> <th>Without cable</th> <th>(2)</th> </tr> <tr> <td>U0</td> <td>Without cable</td> <td>2 to 16 stations</td> </tr> <tr> <td>U1</td> <td>With cable (1.5 m)</td> <td></td> </tr> <tr> <td>U2</td> <td>With cable (3 m)</td> <td></td> </tr> <tr> <td>U3</td> <td>With cable (5 m)</td> <td></td> </tr> </table>		Kit	Without cable	(2)	U0	Without cable	2 to 16 stations	U1	With cable (1.5 m)		U2	With cable (3 m)		U3	With cable (5 m)	
Kit	Without cable	(2)																																																																	
U0	Without cable	2 to 24 stations																																																																	
U1	With cable (1.5 m)																																																																		
U2	With cable (3 m)																																																																		
U3	With cable (5 m)																																																																		
Kit	Without cable	(2)																																																																	
U0	Without cable	2 to 24 stations																																																																	
U1	With cable (1.5 m)																																																																		
U2	With cable (3 m)																																																																		
U3	With cable (5 m)																																																																		
Kit	Without cable	(2)																																																																	
U0	Without cable	2 to 16 stations																																																																	
U1	With cable (1.5 m)																																																																		
U2	With cable (3 m)																																																																		
U3	With cable (5 m)																																																																		
Kit	Without cable	(2)																																																																	
U0	Without cable	2 to 16 stations																																																																	
U1	With cable (1.5 m)																																																																		
U2	With cable (3 m)																																																																		
U3	With cable (5 m)																																																																		

Note 1) Besides the above, F and P kits with different number of pins are available. Refer to page 2-4-177 for details.  
Note 2) For details, refer to page 2-4-178.

### How to Order Valves

**VQ 1 1 0 0 Y - 5**

**Series**  
1 VQ1000

**Type of actuation**  
1 2 position single  
2 Metal 2 position double  
2 Rubber 2 position double  
3 3 position closed center  
3 3 position exhaust center  
3 3 position pressure center  
4 4 position dual 3 port valve  
4 4 position dual 3 port valve  
4 4 position dual 3 port valve

**Seal**  
0 Metal seal  
1 Rubber seal

**Manual override**  
Nil: Non-locking push type (Tool required)  
B: Push-locking slotted type  
C: Locking type (Manual)

**Light/Surge voltage suppressor**  
Nil Yes  
E (Note) None  
Note) Inapplicable to the S kit.

**Function**

Symbol	Specifications	DC	AC
Nil	Standard type	(1.0 W)	(Note)
H	High pressure type	(1.5 W)	—
Y	Low wattage type	(0.5 W)	—

Note) For power consumption of AC type, refer to page 2-4-129.  
Note) For external pilot and negative COM specifications, refer to "Option" on pages 2-4-178 to 2-4-179.

Note) Rubber seal type only.

**Coil voltage**

1	100 VAC (50/60 Hz)
2 (Note)	200 VAC (50/60 Hz)
3	110 VAC (50/60 Hz)
4 (Note)	220 VAC (50/60 Hz)
5	24 VDC
6	12 VDC

Note) 200/220 VAC models are applicable to F and L kits.

### How to Order Manifold Assembly

**Example**

Single solenoid (24 VDC) VQ1100-5 (4 sets)  
Double solenoid (24 VDC) VQ1200-5 (4 sets)  
Blanking plate VQ1000-10A-1 (1 set)  
D-sub connector  
Cylinder ports C6: With One-touch fitting for ø6  
Manifold base (9 stations) VV5Q11-09C6FU2

F kit (D-sub connector)

VV5Q11-09C6FU2 ..... 1 set (F kit 9 station manifold base no.)  
\*VQ1100-5 ..... 4 sets (Single solenoid part no.)  
\*VQ1200-5 ..... 4 sets (Double solenoid part no.)  
\*VV1000-10A-1 ..... 1 set (Blanking plate part no.)

The asterisk denotes the symbol for assembly. Prefix it to the part nos. of the solenoid valve, etc.

Specify the part numbers for valves and options together beneath the manifold base part number. Besides, when the arrangement will be complicated, specify them by means of the manifold specification sheet.

- VQC
- SQ
- VQ0
- VQ4
- VQ5
- VQZ
- VQD

### T kit (Terminal box)

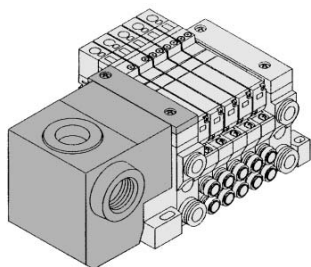

P. 2-4-146

### L kit (Lead wire cable)

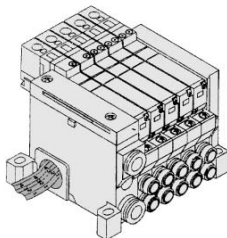

P. 2-4-150

### S kit (Serial transmission unit)

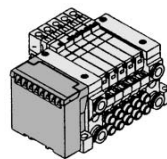

The valve is equipped with an indicator light and surge voltage suppressor, and the voltage is 24 VDC. The dust proof SI unit is also available. Refer to page 2-4-154 for details.

P. 2-4-154

Kit T O Terminal block box 2 to 24 stations (2)

Kit L 0 With cable (0.6 m)  
1 With cable (1.5 m)  
2 With cable (3 m) 1 to 8 stations

Kit S	Specification	Max. stations	
0	Without SI unit		
A	With general type SI unit (Series EX300)		
B	Mitsubishi Electric Corp.: MELSECNET/MINI-S3 Data Link System	Max. 16 stations	
C	OMRON Corp.: SYSBUS Wire System		
D	SHARP Corp.: Satellite I/O Link System		
E	Matsushita Electric Works: MEWNET-F System		
F1	NKE Corp.: Uni-wire System (16 output points)		
G	Rockwell Automation: Allen Bradley Remote I/O (RIO) System		
H	NKE Corp.: Uni-wire H System		
J1	SUNX Corp.: S-LINK System (16 output points)		
J2	SUNX Corp.: S-LINK System (8 output points)		Max. 8 stations
K	Fuji Electric Co.: T-LINK Mini System		Max. 16 stations
Q	DeviceNet, CompoBus/D (OMRON Corp.)		
R1	OMRON Corp.: CompoBus/S System (16 output points)		
R2	OMRON Corp.: CompoBus/S System (8 output points)	Max. 8 stations	
V	Mitsubishi Electric Corp.: CC-LINK System	Max. 16 stations	

Manifold Option

Blanking plate assembly  
VVQ1000-10A-1

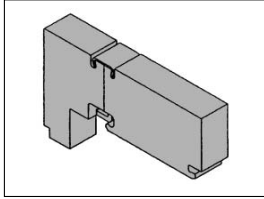

SUP block plate  
VVQ1000-16A

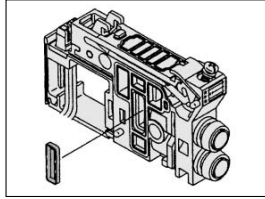

Double check block  
VQ1000-FPG-□□

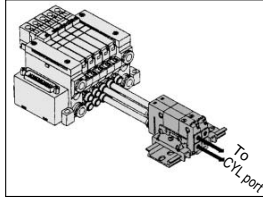

2 stations matching fitting assembly  
VVQ1000-52A-C8

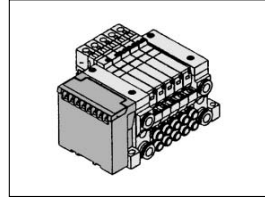

Blanking plug  
KQ2P-  
□□□□□□□□

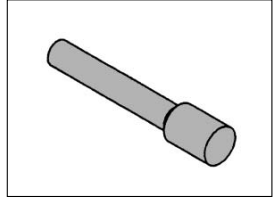

Individual SUP spacer  
VVQ1000-P-1-C6

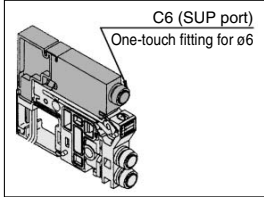

EXH block base assembly  
VVQ1000-19A-  
□□□□□□□□

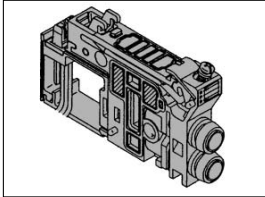

Elbow fitting assembly  
VVQ1000-F-L-  
□□□□□□□□

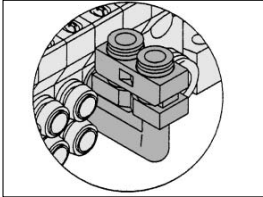

Silencer (For EXH port)  
AN200-KM8/AN203-KM8

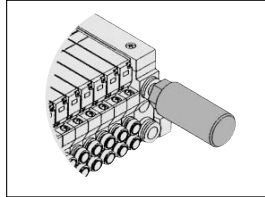

Blanking plate with connector  
VVQ1000-1C□-□

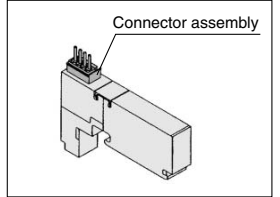

Individual EXH spacer  
VVQ1000-R-1-C6

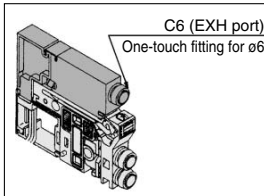

Back pressure check valve assembly [-B]  
VVQ1000-18A

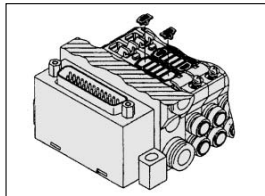

DIN rail mounting bracket [-D]  
VVQ1000-57A

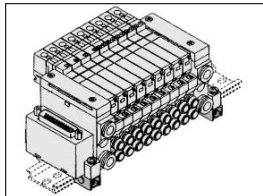

Regulator unit  
VVQ1000-AR-1

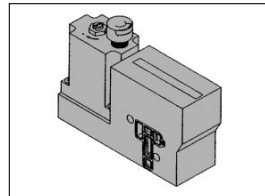

- For cylinder port fittings part no., refer to page 2-4-175.
- For replacement parts, refer to page 2-4-227.

With vacuum ejector unit  
[-J□]

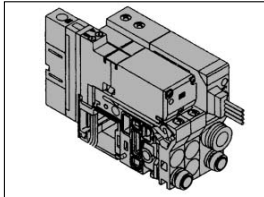

Name plate [-N]  
VVQ1000-<sub>NC</sub> Station (1 to Max. stations)

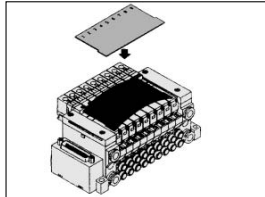

Built-in silencer,  
direct exhaust [-S]

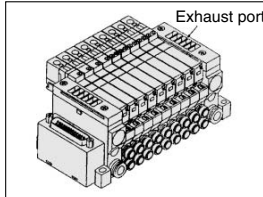

Port plug  
VVQ0000-58A

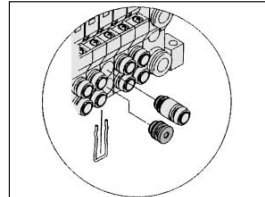

Standard Specifications

JIS Symbol

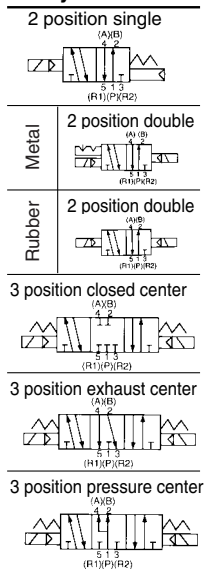

Valve specifications	Valve construction	Metal seal	Rubber seal	
	Fluid	Air/Inert gas	Air/Inert gas	
	Maximum operating pressure	0.7 MPa (High pressure type: 0.8 MPa)		
	Minimum operating pressure	Single	0.1 MPa	0.15 MPa
		Double	0.1 MPa	0.1 MPa
		3 position	0.1 MPa	0.2 MPa
	Ambient and fluid temperature	-10 to 50°C <sup>(1)</sup>		
	Lubrication	Not required		
	Manual override	Push type/Locking type (Tool required, Manual type) Option		
	Impact/Vibration resistance <sup>(2)</sup>	150/30 m/s <sup>2</sup>		
Enclosure	Dust-protected, Dust tight/Low jetproof type (IP65) <sup>(5)</sup>			
Solenoid	Coil rated voltage	12, 24 VDC, 100, 110, 200, 220 VAC (50/60 Hz)		
	Allowable voltage fluctuation	±10% of rated voltage		
	Coil insulation type	Class B or equivalent		
	Power consumption (Current)	24 VDC	1 W DC (42 mA), 1.5 W DC (63 mA) <sup>(3)</sup> , 0.5 W DC (21 mA) <sup>(4)</sup>	
		12 VDC	1 W DC (83 mA), 1.5 W DC (125 mA) <sup>(3)</sup> , 0.5 W DC (42 mA) <sup>(4)</sup>	
		100 VAC	Inrush 1.2 VA (12 mA), Holding 1.2 VA (12 mA)	
		110 VAC	Inrush 1.3 VA (12 mA), Holding 1.3 VA (12 mA)	
200 VAC		Inrush 2.4 VA (12 mA), Holding 2.4 VA (12 mA)		
220 VAC	Inrush 2.6 VA (12 mA), Holding 2.6 VA (12 mA)			

VQC

SQ

VQ0

VQ4

VQ5

VQZ

VQD



Note 1) Use dry air to prevent condensation when operating at low temperatures.  
 Note 2) Impact resistance ... No malfunction occurred when it is tested with a drop tester in the axial direction and at the right angles to the main valve and armature in both energized and de-energized states every once for each condition. (Values at the initial period)  
 Vibration resistance ... No malfunction occurred in a one-sweep test between 45 and 2000 Hz. Test was performed at both energized and de-energized states in the axial direction and at the right angles to the main valve and armature. (Values at the initial period)  
 Note 3) Value for high voltage type (1.5 W)  
 Note 4) Value for low voltage type (0.5 W)  
 Note 5) Dusttight/Low jetproof type (IP65) is available on T, L, S and M kits of VQ2000.

Manifold Specifications

Series	Base model	Type of connection	Porting specifications		Applicable stations <sup>(2)</sup>	Applicable solenoid valve	5 station weight (g)	
			Port location	Port size <sup>(1)</sup>				
VQ1000	VV5Q11-□□□	<ul style="list-style-type: none"> <li>■ F kit—D-sub connector</li> <li>■ P kit—Flat ribbon cable connector</li> <li>■ J kit—Flat ribbon cable connector (20P)</li> <li>■ G kit—Flat ribbon cable connector with terminal block</li> <li>■ T kit—Terminal box</li> <li>■ L kit—Lead wire cable</li> <li>■ S kit—Serial transmission unit</li> </ul>	Side	1(P), 3(R)	4(A), 2(B)	F, P, T kits 2 to 24 stations (J, G, S kit) 2 to 16 stations (L kit) 1 to 8 stations	VQ1□00 VQ1□01	628 (Single) 759 (Double, 3 position)
				C8 (ø8) C3 (ø3.2) C4(ø4) C6 (ø6) M5 (M5 thread)	Option Built-in silencer, direct exhaust			
VQ2000	VV5Q21-□□□	<ul style="list-style-type: none"> <li>■ F kit—D-sub connector</li> <li>■ P kit—Flat ribbon cable connector</li> <li>■ J kit—Flat ribbon cable connector (20P)</li> <li>■ G kit—Flat ribbon cable connector with terminal block</li> <li>■ T kit—Terminal box</li> <li>■ L kit—Lead wire cable</li> <li>■ S kit—Serial transmission unit</li> <li>■ M kit—Multi-connector</li> </ul>	Side	1(P), 3(R)	4(A), 2(B)	F, P kits 2 to 24 stations (J, G, S kit) 2 to 16 stations (L kit) 1 to 8 stations T kit 2 to 20 stations	VQ2□00 VQ2□01	1051 (Single) 1144 (Double, 3 position)
				C10 (ø10) C4 (ø4) C6 (ø6) C8 (ø8)	Option Built-in silencer, direct exhaust			

Note 1) Inch-size One-touch fittings are also available. For details, refer to page 2-4-179.  
 Note 2) For details, refer to page 2-4-178.

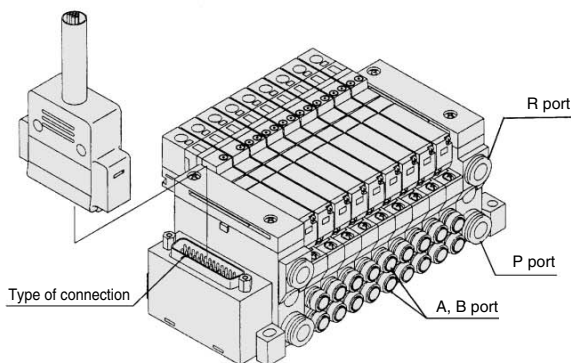

VV5Q11

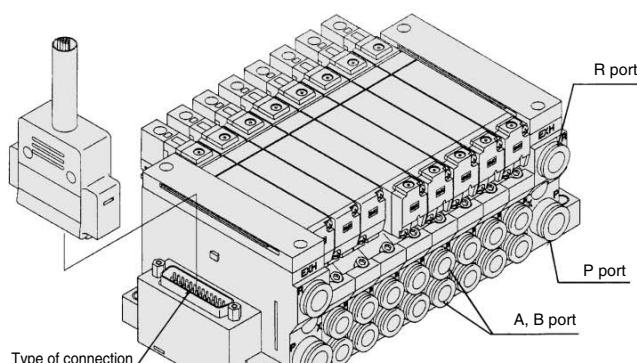

VV5Q21

# S VQ1000/2000 Kit (Serial transmission unit)

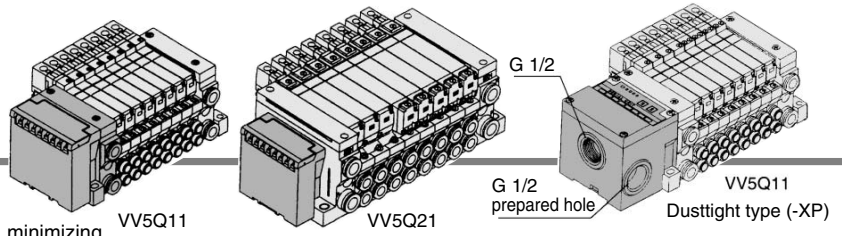

## IP65 compliant

- The serial transmission system reduces wiring work, while minimizing wiring and saving space.
- The system comes in type SA (generic for small scale systems) for equipment with a small number of I/O points, or 32 points max., type SB (applicable to Mitsubishi Electric models) for controlling 512 I/O points max., type SC (applicable to OMRON models), type SD (applicable to SHARP models: 504 points max.), type SF (applicable to NKE models: 128 points max.), type SJ (applicable to SUNX models), type SK (applicable to Fuji Electric models), type SQ (applicable to OMRON's Compo Bus/D), and type SR (applicable to OMRON's Compo Bus/S).
- Max. 16 stations. (Specify a model with 9 to 16 stations by using the manifold specification sheet.)
- Enclosure: Dusttight, Low jetproof type (IP65) compliant (Series VQ2000)

## Manifold Specifications

Series	Porting specifications			Applicable stations
	Port location	Port size		
VQ1000	Side	1(P), 3(R)	4(A), 2(B)	Max. 16 stations
VQ2000	Side	C10	C4, C6, C8	Max. 16 stations

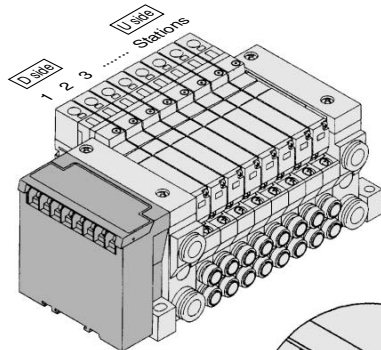

- Stations are counted from station 1 on the D side.
- Double wiring (connected to SOL. A and SOL. B) is adopted for the internal wiring of each station, regardless of valve and option types. The optional specification permits the mixture of single and double wiring. For details, refer to page 2-4-178.

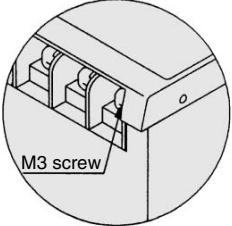

Name of terminal block (LED)	Type SA With general type SI unit (Series EX300)	Type SB Mitsubishi Electric Corporation MELSECNET/mini-S3 Data Link System																	
	<table border="1"> <thead> <tr> <th>LED</th> <th>Description</th> </tr> </thead> <tbody> <tr> <td>TRD</td> <td>Lighting during data reception</td> </tr> <tr> <td>RUN/ERR</td> <td>Blinking when received data is normal; Lighting when data reception</td> </tr> </tbody> </table>	LED	Description	TRD	Lighting during data reception	RUN/ERR	Blinking when received data is normal; Lighting when data reception	<table border="1"> <thead> <tr> <th>LED</th> <th>Description</th> </tr> </thead> <tbody> <tr> <td>POWER</td> <td>Lighting when power is turned ON</td> </tr> <tr> <td>RUN</td> <td>Lighting when data transmission with the master station is normal</td> </tr> <tr> <td>RD</td> <td>Lighting during data reception</td> </tr> <tr> <td>SD</td> <td>Lighting during data transmission</td> </tr> <tr> <td>ERR.</td> <td>Lighting when reception data error occurs. Light turns off when the error is corrected.</td> </tr> </tbody> </table>	LED	Description	POWER	Lighting when power is turned ON	RUN	Lighting when data transmission with the master station is normal	RD	Lighting during data reception	SD	Lighting during data transmission	ERR.
LED	Description																		
TRD	Lighting during data reception																		
RUN/ERR	Blinking when received data is normal; Lighting when data reception																		
LED	Description																		
POWER	Lighting when power is turned ON																		
RUN	Lighting when data transmission with the master station is normal																		
RD	Lighting during data reception																		
SD	Lighting during data transmission																		
ERR.	Lighting when reception data error occurs. Light turns off when the error is corrected.																		
Note	<ul style="list-style-type: none"> <li>● T unit Can be connected with PLC I/O card for serial transmission. EX300-TMB1...For models of Mitsubishi Electric Corporation EX300-TTA1...For models of OMRON Corporation EX300-TFU1...For models of Fuji Electric Co., Ltd. EX300-TOO1... For general models * Up to 32 points per unit.</li> <li>● No. of output points, 16 points</li> </ul>	<ul style="list-style-type: none"> <li>● Master station: PLC made by Mitsubishi Electric Corporation Series MELSEC-A AJ71PT32-S3, AJ71T32-S3 A1SJ71PT32-S3 * Max. 64 stations, connected to remote I/O stations (Max. 512 points).</li> <li>● No. of output points, 16 points. No. of sta. occupied, 2 stations</li> </ul>																	

\* For details on specifications and handling, refer to the separate technical instruction manual.

Item	Specifications
External power supply	24 VDC +10%, -5%
Current consumption (Internal unit)	SA, SB, SBB, SD, SE, SF1, SH, SG, SJ, SK, SQ, SR, SU, SV: 0.1A SC: 0.3A

## How to Order Manifold

**Series** VV5Q 1 1-08 C6 S A N-XP

**Manifold**  
1 VQ1000  
2 VQ2000

**Stations**  
02 2 stations  
16 16 stations

**Cylinder port**

Symbol	Port size	VQ1000	VQ2000
C3	With One-touch fitting for ø3.2	●	
C4	With One-touch fitting for ø4	●	●
C6	With One-touch fitting for ø6	●	●
C8	With One-touch fitting for ø8		●
M5	M5 thread	●	
CM	With mixed size/with port plug	●	● <sup>(3)</sup>

**Model**

Model	Max. stations
O Without SI unit	
A With general type SI unit (Series EX300)	
B Mitsubishi Electric Corp.: MELSECNET/mini-S3 Data Link System	
BB MELSECNET/mini-S3 Data Link System (2 power supply lines)	
C OMRON Corp.: SYSBUS Wire System	
D SHARP Corp.: Satellite I/O Link System	
E Matsushita Electric Works: MEWNET-F System	
F NKE Corp.: Uni-wire System (16 output points)	
G Rockwell Automation: Allen Bradley Remote I/O (RIO) System	
H NKE Corp.: Uni-wire H System	
J1 SUNX Corp.: S-LINK System (16 output points)	Max. 8 stations
J2 SUNX Corp.: S-LINK System (8 output points)	Max. 8 stations
K Fuji Electric Co.: T-LINK Mini System	Max. 16 stations
Q DeviceNet, CompoBus/D (OMRON Corp.)	Max. 16 stations
R1 OMRON Corp.: CompoBus/S System (16 output points)	Max. 8 stations
R2 OMRON Corp.: CompoBus/S System (8 output points)	Max. 16 stations
U JEMANET (JPCN-1)	Max. 16 stations
V Mitsubishi Electric Corp.: CC-LINK System	Max. 16 stations

**Option**

Symbol	Option	VQ1000	VQ2000	Note
Nil	None	●	●	
B	With back pressure check valve	●	●	(2)
D	DIN rail mounting style	●	●	
G1	1 set of regulator unit			(3)
G2	2 sets of regulator unit	●		
G3	3 sets of regulator unit			
J	With vacuum ejector unit	●		(4)
K	Special wiring specifications (Not double wiring)	●	●	(5)
N	With name plate	●	●	
R	with external pilot	●	●	(6)
S	Built-in silencer, direct exhaust	●	●	
W	Enclosure: Dust tight/Low jetproof type (IP65) (Except SE)		●	(8)

- Note 1) Insert "L" (top piping) or "B" (bottom piping) for elbow type. (VQ1000 only). Example B6 (Elbow One-touch fittings for ø6, bottom piping.)
- Note 2) Specify as "LM" for models with elbow fittings and mixed cylinder port sizes.
- Note 3) Specify "Mixed size/with port plug" in the manifold specification sheet.
- Note 4) For inch-size One-touch fittings, refer to "Option" on page 2-4-179.

- Note 1) The general type requires a transmission unit on CPU side.
- Note 2) SBB kit is usable only for VQ2000 dusttight/low jetproof type (IP65).

- Note 1) When two or more symbols are specified, indicate them alphabetically. Example) -BRS.
- Note 2) Models with a suffix "-B" have check valves for prevention of back pressure at all manifold stations. If not all stations need this check valve, specify the stations where check valves are installed by manifold specification sheet.
- Note 3) Specify the mounting position in the manifold specification sheet.
- Note 4) Refer to page 2-4-170 for the details of ejector mounted styles. A combination of "J" and "N" is unavailable.
- Note 5) Specify the wiring specifications in the manifold specification sheet.
- Note 6) Indicate "R" for the valve with external pilot.
- Note 7) A combination of "W" and "XP" is unavailable.
- Note 8) Refer to "Dimensions" on page 2-4-157 for SI unit and valve, in case of W (dusttight/low jetproof type).



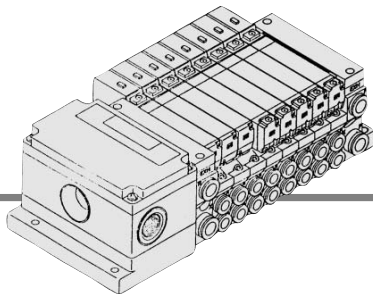

VV5Q21  
Dust tight Low jetproof type (-W)

Mixed wiring is available as an option.  
Use the manifold specification sheet to specify.

● SI unit output and coil numbering

<Wiring example 1>

SI unit	0	1	2	3	4	5	6	7	8	9
output no.										
	A B	A B	A	Un-used	A	Un-used	A B			
SI unit	Double	Double	Single		Single		Double			
Stations	1	2	3		4		5			

Double wiring (Standard)

<Wiring example 2>

SI unit	0	1	2	3	4	5	6	7
output no.								
	A B	A B	A	A	A B			
SI unit	Double	Double	Single	Single	Single			
Stations	1	2	3	4	5			

Single/Double mixed wiring (Option)

VQC

SQ

VQ0

VQ4

VQ5

VQZ

VQD

	Type SC OMRON Corporation SYSBUS Wire System	Type SD SHARP Corporation Satellite I/O Link System															
Name of terminal block (LED)																	
	<table border="1"> <thead> <tr> <th>LED</th> <th>Description</th> </tr> </thead> <tbody> <tr> <td>RUN</td> <td>Lights when transmission is normal and PLC is in operation mode</td> </tr> <tr> <td>T/R ERR</td> <td>Blinks during data transmission/reception ON when transmission is abnormal.</td> </tr> </tbody> </table>	LED	Description	RUN	Lights when transmission is normal and PLC is in operation mode	T/R ERR	Blinks during data transmission/reception ON when transmission is abnormal.	<table border="1"> <thead> <tr> <th>LED</th> <th>Description</th> </tr> </thead> <tbody> <tr> <td>POWER</td> <td>ON when power supply is ON</td> </tr> <tr> <td>RUN</td> <td>Lights when power is ON and slave stations are operating normally</td> </tr> <tr> <td>ERROR</td> <td>Lights when slave station switch setting is abnormal, communication is abnormal, PLC stopped and defective slave unit</td> </tr> <tr> <td>R.SET HOLD</td> <td>ON for master unit control input</td> </tr> </tbody> </table>	LED	Description	POWER	ON when power supply is ON	RUN	Lights when power is ON and slave stations are operating normally	ERROR	Lights when slave station switch setting is abnormal, communication is abnormal, PLC stopped and defective slave unit	R.SET HOLD
LED	Description																
RUN	Lights when transmission is normal and PLC is in operation mode																
T/R ERR	Blinks during data transmission/reception ON when transmission is abnormal.																
LED	Description																
POWER	ON when power supply is ON																
RUN	Lights when power is ON and slave stations are operating normally																
ERROR	Lights when slave station switch setting is abnormal, communication is abnormal, PLC stopped and defective slave unit																
R.SET HOLD	ON for master unit control input																
Note	<ul style="list-style-type: none"> <li>Master station unit: OMRON PLC SYSMAC C (CV) series Types C500-RM201 and C200H-RM201</li> <li>* 32 units max., transmission terminal connection (512 points max.)</li> <li>No. of output points, 16 points</li> </ul>	<ul style="list-style-type: none"> <li>Master station unit: SHARP's PLC New Satellite Series W ZW-31LM New Satellite Series JW JW-23LM, JW 31LM</li> <li>* Max. 31 units, I/O slave stations connected (504 points max.)</li> <li>No. of output points, 16 points</li> </ul>															

How to Order Valves

VQ 1 1 0 0 Y - 5

**Series**

1	VQ1000
2	VQ2000

**Type of actuation**

1	2 position single
2	2 position double
3	3 position closed center
4	3 position exhaust center
5	3 position pressure center

**Seal**

0	Metal seal
1	Rubber seal

**Enclosure**

Nil	Dust-protected
W	Dust tight/Low jetproof (Note) type (IP65)

Note) VQ2000 only.

**Manual override**

Nil	Non-locking push type (Tool required)
B	Locking type (Tool required)
C	Locking type (Manual)

**Coil voltage**

5	24 VDC; With indicator light/surge voltage suppressor
---	---

**Function**

Symbol	Specifications	DC
Nil	Standard type	(1.0 W) ○
H	High pressure type	(1.5 W) ○
Y	Low wattage type	(0.5 W) ○

Note) For external pilot and negative COM specifications, refer to "Option" on pages 2-4-178 to 2-4-179.

How to Order Manifold Assembly

Specify the part numbers for valves and options together beneath the manifold base part number.

<Example>

Serial transmission kit  
VV5Q11-08C6SA ... 1 set—Manifold base no.  
\*VQ1100-5 ..... 2 sets—Valve part no. (Stations 1 to 2)  
\*VQ1200-5 ..... 4 sets—Valve part no. (Stations 3 to 6)  
\*VQ1300-5 ..... 1 set—Valve part no. (Station 7)  
\*VVQ1000-10A-1 ... 1 set—Blanking plate part no. (Station 8)

Prefix the asterisk to the part nos. of the solenoid valve, etc.  
Write sequentially from the 1st station on the D side. When part nos. written collectively are complicated, specify by using the manifold specification sheet.

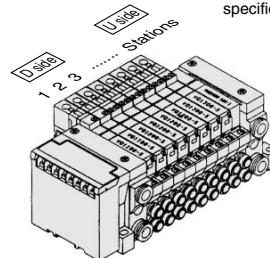

# S VQ1000/2000 Kit (Serial transmission unit)

VQ1000

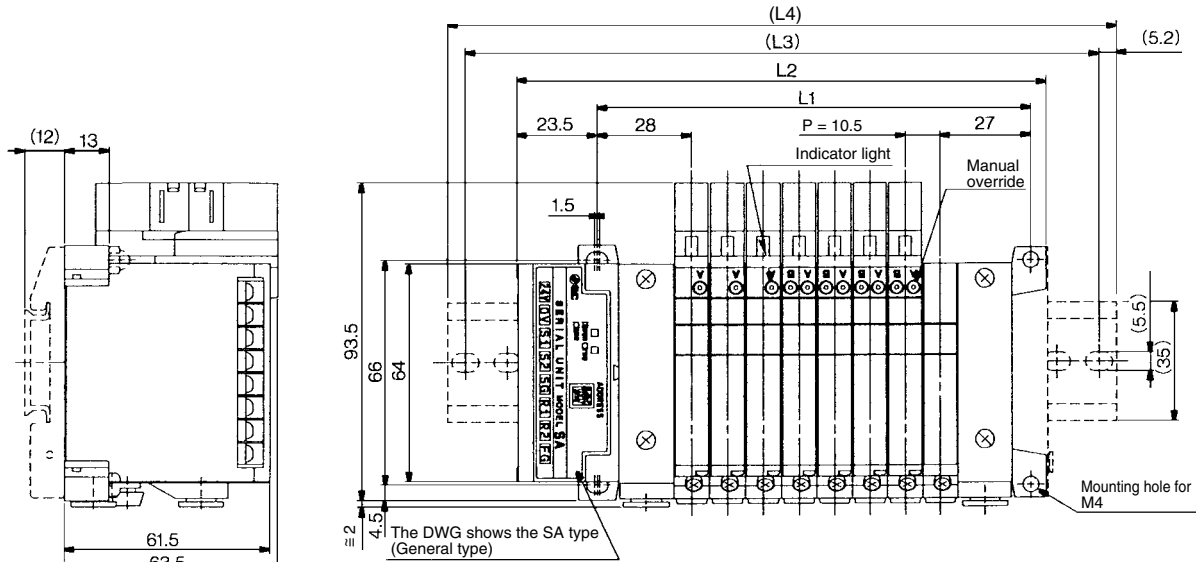
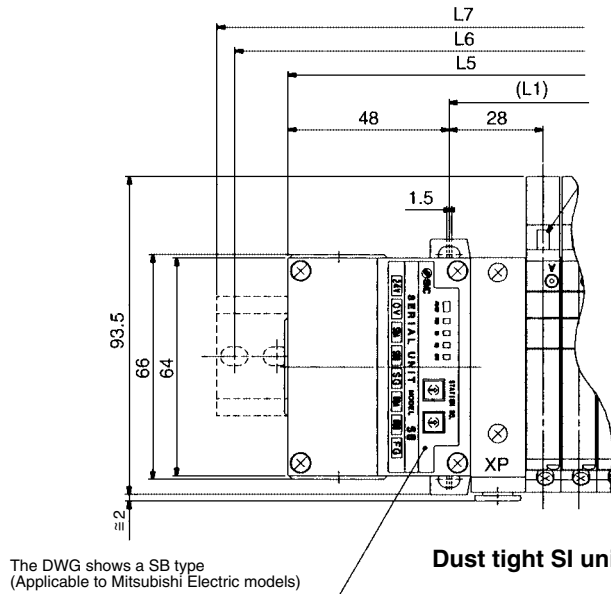

[D side] Stations 1... 2... 3... 4... 5... 6... 7... 8... n [U side]

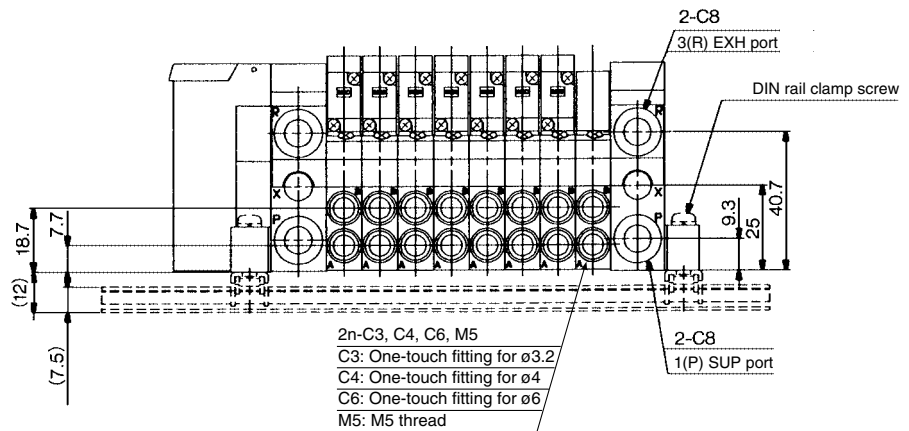

Vacuum ejector unit style: Formula  
 $L1 = 10.5n + 28.7 + (\text{Number of ejector units} \times 26.7)$   
 $L2 = 10.5n + 56.3 + (\text{Number of ejector units} \times 26.7)$   
 $L4$  is  $L2$  plus about 30.

Note) Manifolds with SI unit for Matsushita Electric Works' MEWNET FP and Rockwell Automation's model are the same with  $L5$ ,  $L6$  and  $L7$  dimensions of dustproof SI unit.

## Dimensions

Dust-protected type SI unit:  $L5 = 10.5n + 97$ ,  $L6 = L3 + 25$ ,  $L7 = L4 + 25$   
 Formula  $L1 = 10.5n + 44.5$ ,  $L2 = 10.5n + 72.5$  n: Station (Maximum 16 stations)

L	n	2	3	4	5	6	7	8	9	10	11	12	13	14	15	16
L1		65.5	76	86.5	97	107.5	118	128.5	139	149.5	160	170.5	181	191.5	202	212.5
L2		93.5	104	114.5	125	135.5	146	156.5	167	177.5	188	198.5	209	219.5	230	240.5
(L3)		125	125	137.5	150	162.5	175	187.5	187.5	200	212.5	225	237.5	250	250	262.5
(L4)		135.5	135.5	148	160.5	173	185.5	198	198	210.5	223	235.5	248	260.5	260.5	273

# Series VQ1000

## Manifold Option Parts for VQ1000

### Blanking plate assembly VVQ1000-10A-1

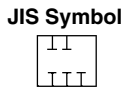

It is used by attaching on the manifold block for being prepared for removing a valve for maintenance reasons or planning to mount a spare valve, etc.

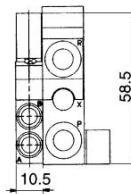
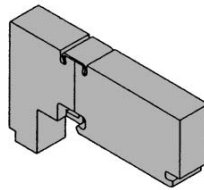

### Individual SUP spacer VVQ1000-P-1-C6

When the same manifold is to be used for different pressures, individual SUP spacers are used as SUP ports for different pressures. (One station space is occupied.)

Block both sides of the station, for which the supply pressure from the individual SUP spacer is used, with SUP block plates. (Refer to the application ex.)

\* Specify the spacer mounting position and SUP block plate position on the manifold specification sheet.

The block plate are used in two places for one set. (Two SUP block plates for blocking SUP station are attached to the individual SUP spacer.)

\* Electric wiring is connected to the position of the manifold station where the individual SUP spacer is mounted.

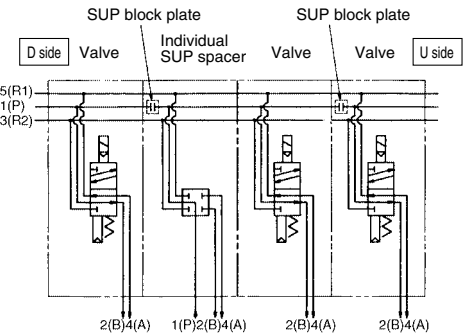
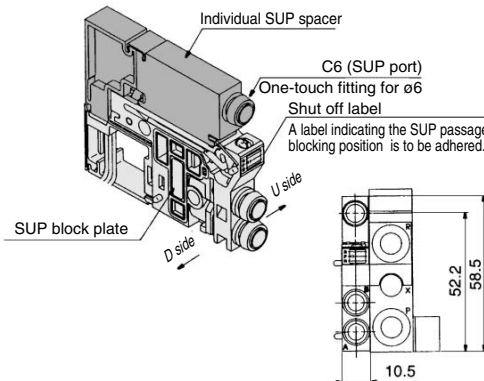

### Individual EXH spacer VVQ1000-R-1-C6

When valve exhaust affects other stations due to the circuit configuration, this spacer is used for individual valve exhaust. (One station space is occupied.)

Block both sides of the individual valve EXH station. (See example)

\* Specify the mounting position, as well as the EXH block base or EXH block plate position on the manifold specification sheet. The block plate are used in two places for one set. (Two EXH block plates for blocking EXH station are attached to the individual EXH spacer.)

\* An EXH block base assembly is used in the blocking position when ordering an EXH spacer incorporated with a manifold no. However, do not order an EXH block base assembly because it is attached to the spacer.

When separately ordering an individual EXH spacer, separately order an EXH block base assembly because it is not attached to the spacer.

\* Electric wiring is connected to the position of the manifold station where the individual EXH spacer is mounted.

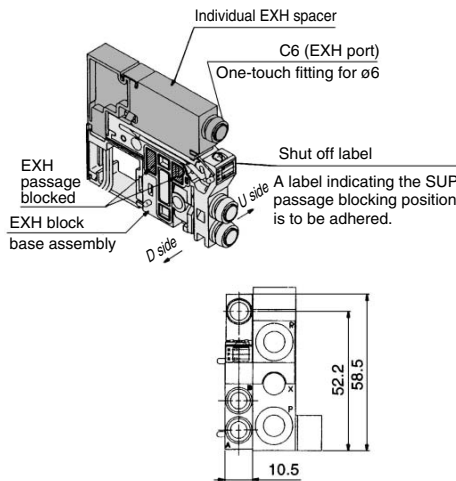

Description/Model		Stations						
		1	2	3	4	5	6	7
Valve	Single	●	●	●				
Option	Individual EXH spacer VVQ1000-R-1-C6		●					
	EXH shut off position: Specify 2 places.	●		●				

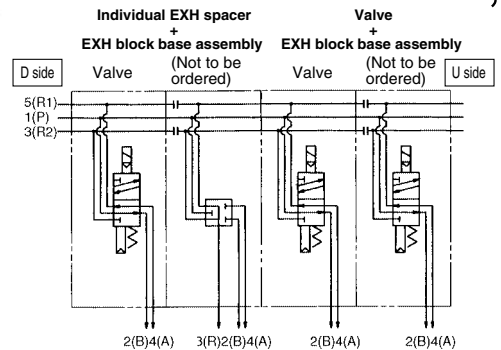

### SUP block plate VVQ1000-16A

When different pressures, high and low, are supplied to one manifold, a SUP block plate is inserted between the stations under different pressures.

\* Specify the number of stations on the manifold specification sheet.

#### <Shut off label>

When using block plates for SUP passage, indication label for confirmation of the blocking position from outside is attached. (One label of each)

\* When ordering a block plate incorporated with the manifold no., a block indication label is attached to the manifold.

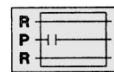
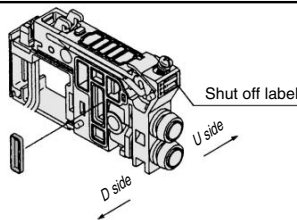

SUP passage block

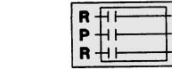
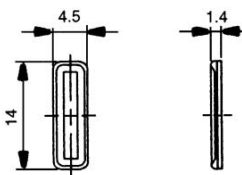

SUP/EXH passage blocked

### Blanking plate with connector VVQ1000-1C-

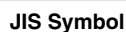

Style of manifold	Connector	Lead wire length (mm)			
		Nil	300	20	2000
1	VV5Q11	6	600	25	2500
		10	1000	30	3000
		15	1500		

Blanking plate with a connector for individually outputting electricity to drive a single valve or equipment that are not on the manifold base.

\* When "N" is suffixed to the nameplate, the plate will be different from a standard shape.

Note) Electric current should be 1A or less. (Including the mounted valves.)

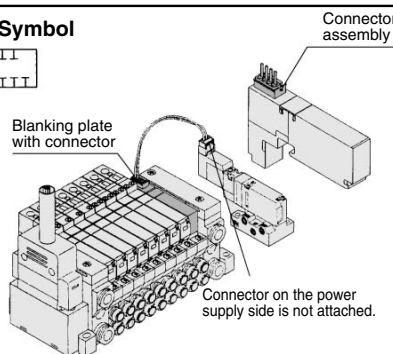

### Connector assembly part no. AXT661-43A-6

Lead wire length: L	Lead wire length: L			
	Nil	300 mm	6	600 mm
	6	600 mm	10	1000 mm
	20	2000 mm	30	3000 mm

Lead wire color: Black  
Lead wire color: Red  
Lead wire color: White

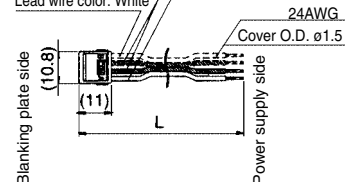



**EXH block base assembly**  
**VVQ1000-19A-□ (C3, C4, C6, M5)**

**Manifold block assembly**  
**Electrical entry**

F1	For F kit (2 to 12 stations)/Double wiring
F2	For F kit (13 to 24 stations)/Double wiring
F3	For F kit (2 to 24 stations)/Single wiring
P1	For P, G, T, S kit (2 to 12 stations)/Double wiring
P2	For P, G, T, S kit (13 to 24 stations)/Double wiring
P3	For P, G, T, S kit (2 to 24 stations)/Single wiring
L0*	L0 kit
L1*	L1 kit
L2*	L2 kit

\* 1 to 8 stations

The manifold block assembly is used between stations for which exhaust is desired to be divided when valve exhaust affects other stations due to the circuit configuration. The EXH passage on the D-side is blocked in the EXH block base assembly. It is also used in combination with an individual EXH spacer for individual exhaust.

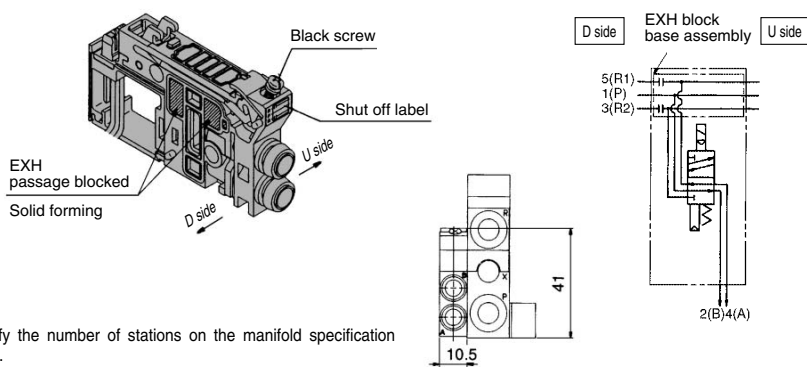

- \* Specify the number of stations on the manifold specification sheet.
- \* When ordering by using the manifold specification form, specify the EXH block base assembly no. by adding suffix "\*" below the manifold no.

**<Blocking indication label>**

When blocking the EXH passage with an EXH block base assembly, indication label for confirmation of the blocking position from outside is attached. (One label for each)

- \* When ordering a EXH block base incorporated with the manifold no., a block indication label is attached to the manifold.

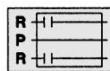

EXH passage blocked

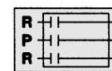

SUP/EXH passage blocked

**Back pressure check valve assembly [-B]**  
**VVQ1000-18A**

It prevents cylinder malfunction caused by other valve exhaust. Insert it into R (EXH) port on the manifold side of a valve which is affected. It is effective when a single action cylinder is used or an exhaust center type solenoid valve is used.

Note) When a check valve for back pressure prevention is desired, and is to be installed only in certain manifold stations, write clearly the part no. and specify the number of stations by using the manifold specification sheet.

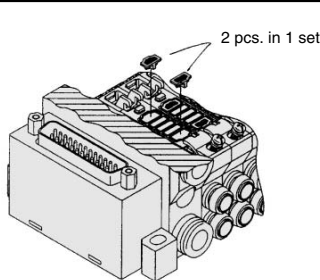

- \* When ordering assemblies incorporated with a manifold, add suffix "-B" to the manifold no.

(Precautions)

1. The back pressure check valve assembly parts with a check valve structure. However, as slight air leakage is allowed for the back pressure, take care the exhaust air will not be throttled at the exhaust port.
2. When a back pressure check valve is mounted, the effective area of the valve will decrease, by about 20%.

**Name plate [-N]**  
**VVQ1000-<sup>N</sup>NC N-Station (1 to Max. stations)**

It is a transparent resin plate for placing a label that indicates solenoid valve function, etc. Insert it into the groove on the side of the end plate and bend it as shown in the figure.

- \* When the blanking plate with connector is mounted, it automatically will be "VVQ1000-NC-n" with an option symbol [-N]

N: Standard  
 NC: For mounting blanking plate with connector

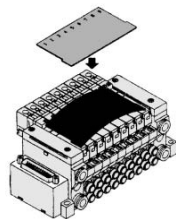

- \* When ordering assemblies incorporated with a manifold, add suffix "-N" to the manifold no.

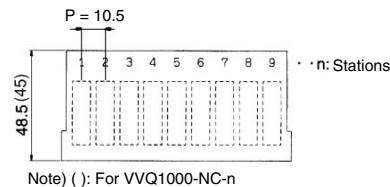

**Blanking plug (For One-touch fittings)**

**KQ2P-<sup>23</sup><sub>04</sub><sub>06</sub><sub>08</sub>**

It is inserted into an unused cylinder port and SUP/EXH ports. Purchasing order is available in units of 10 pieces.

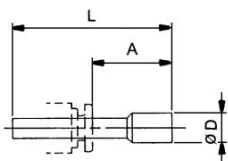
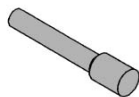

**Dimensions**

Applicable fittings size od	Model	A	L	D
3.2	KQ2P-23	16	31.5	3.2
4	KQ2P-04	16	32	6
6	KQ2P-06	18	35	8
8	KQ2P-08	20.5	39	10

**Port plug**  
**VVQ000-58A**

The plug is used to block the cylinder port when using a 4 port valve as a 3 port valve.

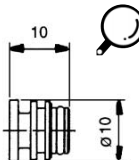
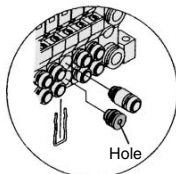

- \* When ordering a plug incorporated with a manifold, indicate "CM" for the port size in the manifold no., as well as, the mounting position and number of stations and cylinder port mounting positions, A and B, on the manifold specification sheet.
- \* Lightly screw an M3 screw in the port plug hole and pull it for removal.

**Elbow fitting assembly**  
**VVQ1000-F-L (C3, C4, C6, M5)**

It is used for piping that extends upward or downward from the manifold.

When installing it in part of the manifold stations, specify the assembly no. and the mounting position and number of stations by means of the manifold specification sheet.

- \* When mounting elbow fittings assembly on the edge of manifold station and a silencer on EXH port, select a silencer, AN203-KM8. Silencer (AN200-KB8) is interfered with fittings.

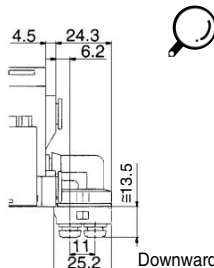
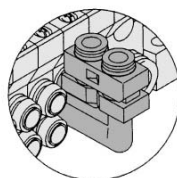

- \* When ordering assemblies incorporated with a manifold, indicate "L□" or "B□" for the manifold port size. (When installed in all stations.)

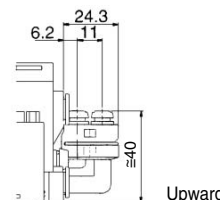

# Series VQ1000

## Manifold Option Parts for VQ1000

### DIN rail mounting bracket

#### VVQ1000-57A

It is used for mounting a manifold on a DIN rail. The DIN rail mounted bracket is fixed to the manifold end plate. (The specification is the same as that for the option "-D".)

1 set of DIN rail mounting bracket is used for 1 manifold (2 DIN rail mounting brackets).

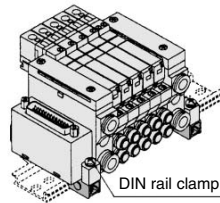

\* When ordering assemblies incorporated with a manifold, add suffix "D" to the manifold no.

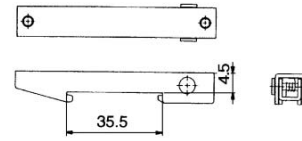

Mounting screws are attached

### Built-in silencer, Direct exhaust [-S]

This is a type with an exhaust port a top the manifold end plate. The built-in silencer exhibits an excellent noise suppression effect. (Silencing effect: 30 dB)



Note) A large quantity of drainage generated in the air source results in exhaust of air together with drainage. For maintenance, refer to page 2-4-176.

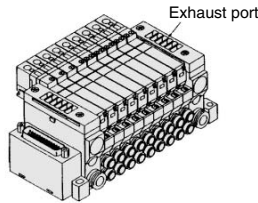

\* When ordering assemblies incorporated with a manifold, add suffix "S" to the manifold no.

### 2 stations matching fitting assembly

#### VVQ1000-52A-C8

For driving a cylinder with a large bore, valves for two stations are operated to double the flow rate. This assembly for the cylinder port is used in that case. The assembly is equipped with One-touch fittings for a ø8 bore.

\* The bore for the manifold no. is "CM".

Clearly indicate the 2 station matching fitting assembly no., and specify the number of stations and positions by means of the manifold specifications.

\* In 2 station matching fitting assembly, a special clip which is combined in one-piece of 2 stations is attached as a holding clip.

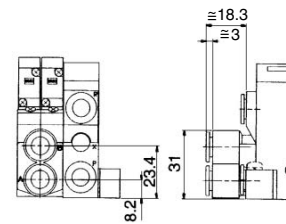
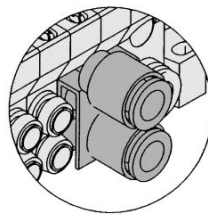

### Silencer (For EXH port)

This silencer is to be inserted into the EXH port (One-touch fittings) of the common exhaust type

\* When mounting elbow fittings assembly (VVQ1000-F-L□) on the edge of manifold station, select a silencer, AN203-KM8.

Silencer (AN200-KM8) is interfered with fittings.

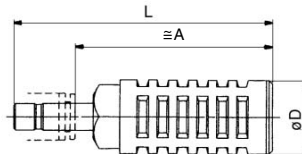

### Dimensions

Series	Applicable fittings size ød	Model	A	L	D	Effective area (mm <sup>2</sup> )	Noise reduction (dB)
VQ1000	8	AN200-KM8	59	78	22	20	30
		AN203-KM8	32	51	16	14	25*

### Regulator unit

#### VVQ1000-AR-1

The regulator controls the SUP air pressure in a manifold. Supply air from D side SUP port is regulated. SUP port on U side is plugged.

### Specifications

Maximum operating pressure	0.8 MPa
Set pressure range	0.05 to 0.7 MPa
Ambient and fluid temp.	5 to 50°C
Fluid	Air
Cracking pressure	0.02 MPa
Structure	Relieving type

Pressure gauge G27-10-01

Pressure control screw

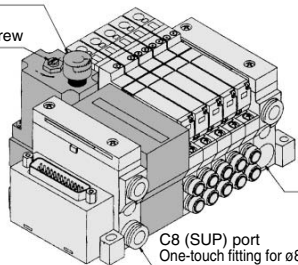

### • How to Order

Indicate an option symbol "-G\*" for the manifold no. and be sure to specify the mounting position and number of stations by means of the manifold specification form. One unit is counted as one station and occupies a space for three stations, therefore, pay attention to the manifold size.

The regulator valve unit, to which no wire is connected, valves can be mounted up to the standard max. number of stations of each kit.

### How to order manifold

#### VV5Q11-14C6FUO-DG2

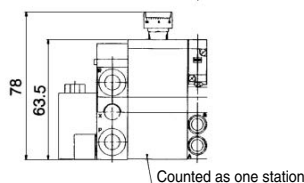
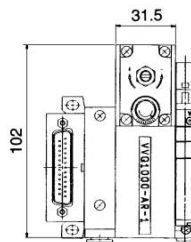
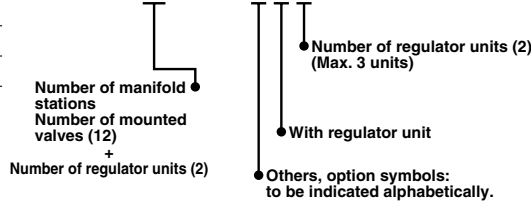

### Flow Characteristics

Conditions: Inlet pressure 0.7 MPa

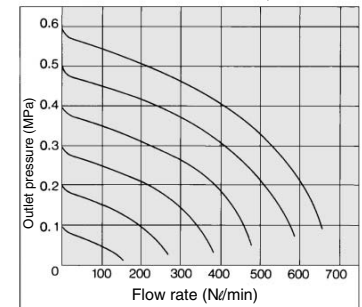

### Pressure characteristics

Conditions (Initial setting) Inlet pressure 0.7 MPa, Outlet pressure 0.2 MPa

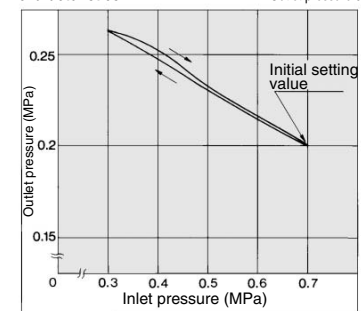

### ⚠ Caution

#### • Pressure setting

Check the supply pressure and then turn the pressure control screw to set the secondary pressure. Turning the screw clockwise will increase the secondary pressure while turning it counterclockwise decrease the pressure. (Set the pressure by turning the screw in the increase direction.)

#### • Installation

Since some level of the actuator's operational frequency may lead to a sharp pressure change, pay attention to the pressure gauge durability.

**Double check block (Separated type): For VQ1000**  
**VQ1000-FPG-□□**

It is used on the outlet side piping to keep the cylinder in the intermediate position for a long time. Combining the double check block with a built-in pilot type double check valve and a 3 position exhaust center solenoid valve will enable the cylinder to stop in the middle or maintain its position for a long time.

The combination with a 2 position single/double solenoid valve will permit this block to be used for preventing the dropping at the cylinder stroke end when the SUP residual pressure is released.

**Specifications**

Max. operating pressure	0.8 MPa
Min. operating pressure	0.15 MPa
Ambient and fluid temp.	-5 to 50°C
Flow characteristics: C	0.60 dm <sup>3</sup> /(s·bar)
Max. operating frequency	180 CPM

Note) Based on JIS B 8375-1981  
 (Supply pressure: 0.5 MPa)

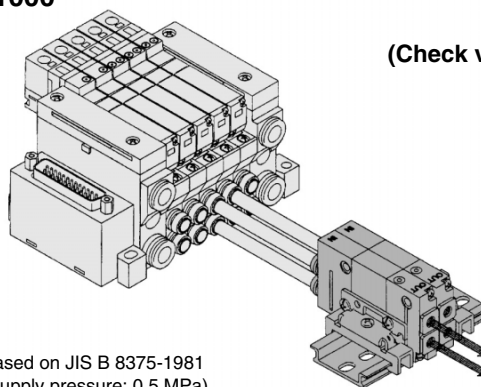

(Check valve operation principle)

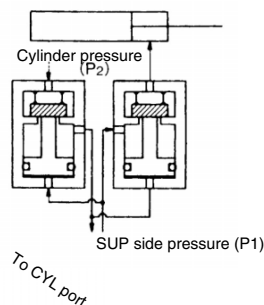

VVQ1000-FPG-02 1 set  
 \* VQ1000-FPG-C6M5-D 2 pcs.

VQC

SQ

VQ0

VQ4

VQ5

QZ

QD

**Dimensions**

**Single unit**

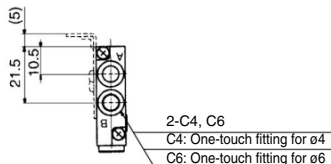

**Manifold**

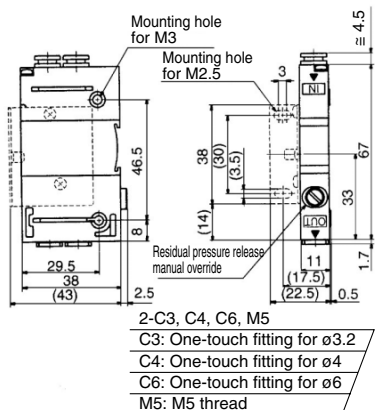
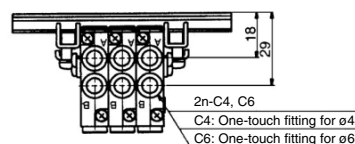

**Dimensions** Formula L1 = 11n + 20 n: Station (Maximum 24)

L <sub>n</sub>	1	2	3	4	5	6	7	8	9	10	11	12
L1	31	42	53	64	75	86	97	108	119	130	141	152
L2	50	62.5	75	87.5	100	112.5	125	137.5	150	162.5	175	
L3	60.5	73	85.5	98	110.5	123	135.5	148	160.5	173	185.5	

L <sub>n</sub>	13	14	15	16	17	18	19	20	21	22	23	24
L1	163	174	185	196	207	218	229	240	251	262	273	284
L2	187.5	187.5	200	212.5	225	237.5	250	250	262.5	275	287.5	300
L3	198	198	210.5	223	235.5	248	260.5	260.5	273	285.5	298	310.5

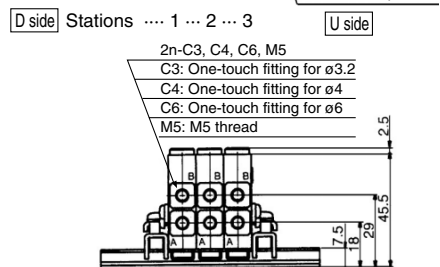

**How to Order**

**Double check block**

VQ1000-FPG-**C4** **M5** **F**

**IN side port size**

C4	With One-touch fitting for ø4
C6	With One-touch fitting for ø6

**OUT side port size**

M5	M5 thread
C3	One-touch fitting for ø3.2
C4	One-touch fitting for ø4
C6	One-touch fitting for ø6

**Option**

Nil	None
F	With bracket
D	DIN rail mounting style (For manifold)
N	Name plate

Note) When two or more symbols are specified, indicate them alphabetically. Example) -DN

**Manifold**

VVQ1000-FPG-**06**

**Stations**

01	1 station
⋮	⋮
16	16 stations

**<Example>**

VVQ1000-FPG-06-6 types of manifold  
 \*VQ1000-FPG-C4M5-D, 3 sets } Double Check block  
 \*VQ1000-FPG-C6M5-D, 3 sets }

**Bracket Assembly**

Part no.	Tightening torque
VQ1000-FPG-FB	0.22 to 0.25 N·m

**Caution**

- Air leakage from the pipe between the valve and cylinder or from the fittings will prevent the cylinder from stopping for a long time. Check the leakage using neutral household detergent, such as dish washing soap. Also check the cylinder's tube gasket, piston packing and rod packing for air leakage.
- Since One-touch fittings allow slight air leakage, screw piping (with M5 thread) is recommended when stopping the cylinder in the middle for a long time.
- Combining double check block with 3 position closed center or pressure center solenoid valve will not work.
- M5 fitting assembly is attached, not incorporated into the double check block. After screwing in the M5 fittings, mount the assembly on the double check block. {Tightening torque: 0.8 to 1.2 N·m}
- If the exhaust of the double check block is throttled too much, the cylinder may not operate properly and may not stop intermediately.
- Set the cylinder load so that the cylinder pressure will be within two times that of the supply pressure.

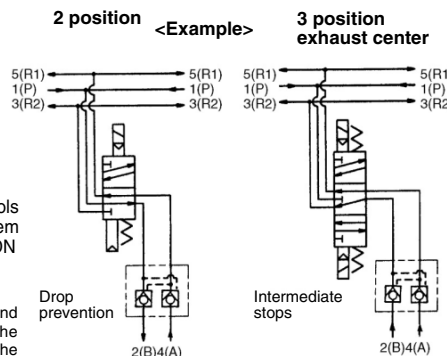

Manifold Option/Vacuum Ejector Unit: VQ1000

A vacuum ejector unit can be mounted on the manifold base for a solenoid valve. Instead of mounting the valve and vacuum ejector unit separately, this option reduces piping, wiring and creates additional space savings.

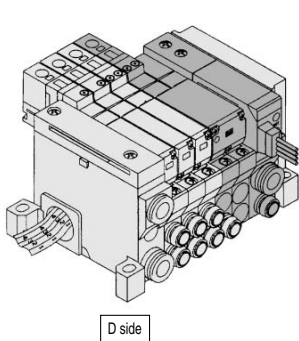

- Note 1) SUP and EXH ports on the vacuum ejector unit manifold base are arranged on D side alone. The end plate on the U side is the same as that used in the L kit.
- Note 2) Individual piping is provided for the supply and exhaust ports of the vacuum ejector unit.
- Note 3) The manifold with an vacuum ejector unit type is mounted from the U side.
- Note 4) One vacuum ejector unit corresponds to one station.  
\* Specify the position of stations on the manifold specification sheet.

Specifications

Unit no.	VVQ1000-J□-□□□-A	VVQ1000-J□-□□□-B
Nozzle diameter (mm)	0.7	1.0
Max. suction flow rate N (ℓ/min)	11	20
Max. vacuum pressure	-630 mmHg	
Max. operating pressure	0.8 MPa	
Standard supply pressure	0.5 MPa	
Operating temperature	5 to 50°C	

Maximum Number of Ejector Units

(Max. number of ejector units is subject to the number of valve stations.)

Max. number of ejector units	Max. number of mounted valves		
	F, P, T kit	S, G, J kit	L kit
1	11(20)	7(14)	7
2	10(16)	6(12)	6
3	9(12)	5(10)	5
4	8(8)	4(8)	—
5	4(4)	3(4)	—

Note) The max. number of mounted valves applies to double wiring. Parenthesized numbers apply to single wiring. Please contact SMC for conditions other than the above or mixed wiring.

Dimensions

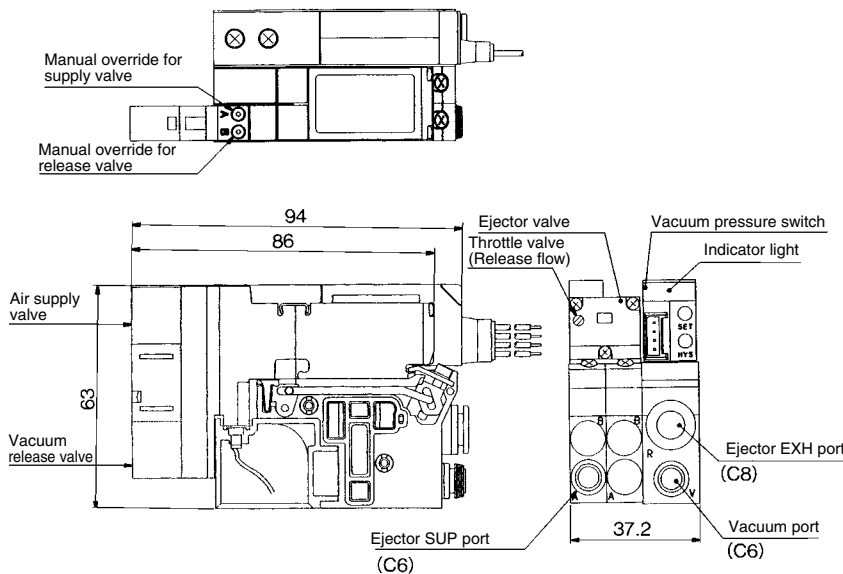

How to Order

VV5Q11-05C6FUO-J **P** **1** **S**

Vacuum switch

Nil	None
P	With

Others, option symbols: to be indicated alphabetically.

Ejection unit  
1 to 5

Example) VV5Q11-05C6FUO-JP1...1 set—Manifold part no.

- \*VQ1100-5 ..... 2 sets—Valve part no. (Stations 1 to 2)
- \*VQ1200-5 ..... 2 sets—Valve part no. (Stations 3 to 4)
- \*VVQ1000-J1-5-A ... 1 set—Ejector valve part no.
- \*ZSE1-00-15-CL ..... 1 set—Vacuum switch part no.

- Note 1) Count one ejector unit as one manifold station.
- Note 2) The ejector unit is mounted next to the U-side end plate.
- Note 3) The U-side end plate is used exclusively for ejector units. (Without P and R port)
- Note 4) The dimension of manifold with an ejector unit is different from the standard dimension. See the formula for calculating the dimensions for each kit.

How to Order Vacuum Ejector Valves

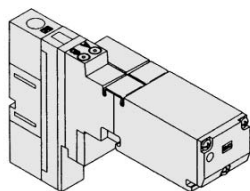

VVQ1000 – J 1 – 5 H C – A

Manifold  
1 Plug-in unit

Coil voltage

1	100 VAC (50/60 Hz)	5	24 VDC
2	200 VAC (50/60 Hz)	6	12 VDC
3	110 VAC (50/60 Hz)	9	Others
4	220 VAC (50/60 Hz)		

Specifications

Symbol	Nozzle diameter	Vacuum release valve
A	ø0.7	With
B	ø1.0	

Manual override

Nil	Non-locking push type
B	Locking type (Tool required)
C	Locking type (Manual)

Function

Symbol	Specifications	DC	AC
Nil	Standard type	(1.0W) ○	○ <sup>(1)</sup>
H	High pressure type	(1.5 W) ○	—
Y	Low wattage type	(0.5W) ○	—
N	Negative COM	○	—



Note 1) For power consumption of AC type, refer to page 2-4-129.  
Note 2) When two or more symbols are specified, indicate them alphabetically.

VQC

SQ

VQ0

VQ4

VQ5

VQZ

VQD

How to Order Vacuum Pressure Switches

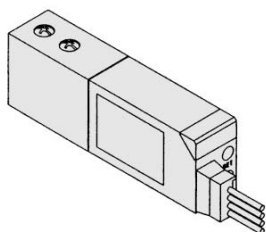

ZSE1 – 00 – 15 – CL

Switch/Voltage (Solid state: 12 to 24 VDC)

14	NPN/1 setting, 3 revolution adjustment
15	NPN/1 setting, 200° adjustment
16	NPN/2 setting, 3 revolution adjustment
17	NPN/2 setting, 200° adjustment
18	NPN/1 setting, 3 revolution adjustment, analog
19	NPN/1 setting, 200° adjustment, analog

Wiring specifications

Nil	Grommet type, Lead wire length 0.6 m
L	Grommet type, Lead wire length 3 m
C	Connector type, Lead wire length 0.6 m
CL	Connector type, Lead wire length 3 m
CN	Without connector <sup>Note)</sup>

Note) When ordering the switch with 5 m lead wire length, order separately the switch without connector and the connector. (Refer to below.) Besides, as for details, refer to the Vacuum Equipment catalog.

How to order connectors

- Without lead wire (Connector 1 pc., Socket 4 pcs.) ..... ZS-20-A
- With lead wire ..... ZS-20-5A-50

Lead wire length

Nil	0.6 m
30	3 m
50	5 m

(The flow characteristics are for the supply pressure of 0.5 MPa.)

Flow/Exhaust Characteristics of Ejector Unit

Nozzle Diameter ø0.7  
Exhaust Characteristics

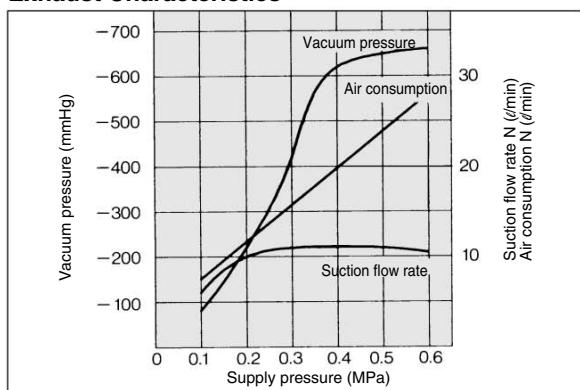

Flow Characteristics

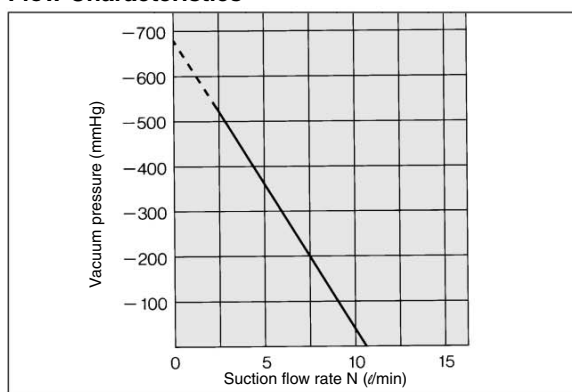

Nozzle Diameter ø1.0

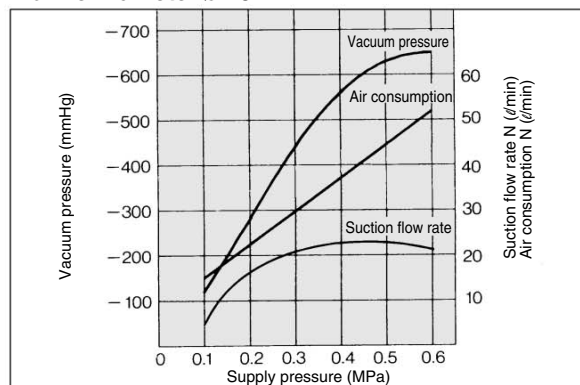

Flow Characteristics

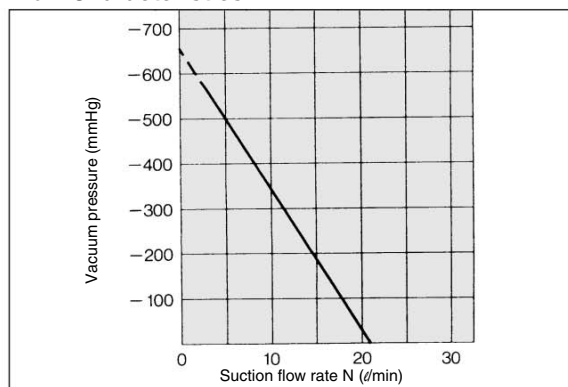

# ⚠ Precautions 1

**Be sure to read before handling. For Safety Instructions and Solenoid Valve Precautions, refer to page 2-9-2.**

## Light/Surge Voltage Suppressor

### ⚠ Caution

The lighting positions are concentrated on one side for both single solenoid type and double solenoid type. In the double solenoid type, A side and B side energization are indicated by two colors which match the colors of the manual overrides.

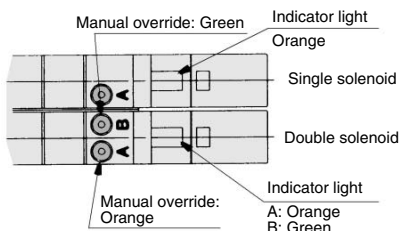

(DWG shows a VQ1000 case.)

### DC circuit diagram Single solenoid

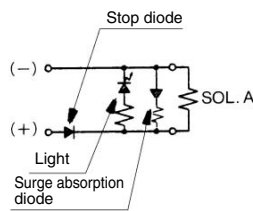

Note)  
A side energization: A light (orange) illuminates.  
B side energization: B light (green) illuminates.

### Double solenoid

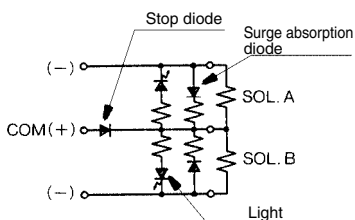

With wrong wiring preventing ability (stop diode).  
Equipped with a surge absorption (surge absorption diode) mechanism.

## Manual Override

### ⚠ Warning

Without an electric signal for the solenoid valve the manual override is used for switching the main valve.

Push type is standard. (Tool required)

Option: Locking type (Tool required/Manual)

#### ■ Push type (Tool required)

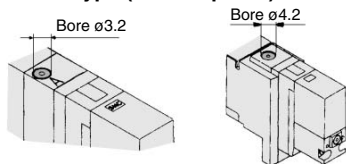

Push down on the manual override button with a small screwdriver until it stops. Release the screwdriver and the manual override will return.

#### ■ Locking type (Tool required) <Option>

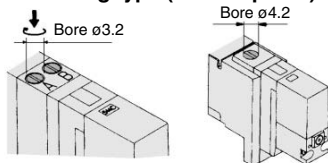

Push down on the manual override button with a small screwdriver or with your fingers until it stops. Turn clockwise by 90° to lock it. Turn it counterclockwise to release it.

#### ■ Locking type (Manual) <Option>

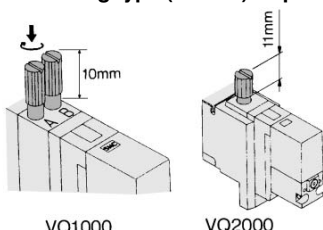

Push down on the manual override button with a small screwdriver or with your fingers until it stops. Turn clockwise by 90° to lock it. Turn it counterclockwise to release it.

### ⚠ Caution

Do not apply excessive torque when turning the locking type manual override. (0.1 N·m or less)

## How to Mount/Remove Solenoid Valve

### ⚠ Caution

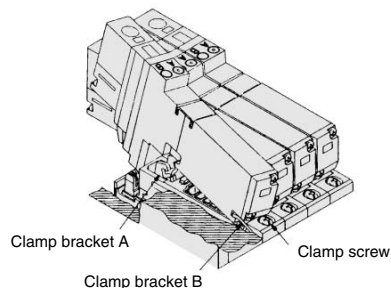

#### Removing

1. Loosen the clamp screw until it turns freely. (The screw is captive.)
2. Lift the coil side of the valve body while pressing down slightly on the screw head and remove it from the clamp bracket B. When the screw head cannot be pressed easily, gently press the area near the manual override of the valve.

#### Mounting

1. Press down on the clamp screw. → Clamp bracket A opens. Diagonally insert the hook on the valve end plate side into clamp B.
2. Press the valve body downward. (When the screw is released, it will be locked by clamp bracket A.)
3. Tighten the clamp screw. (Proper tightening torque: VQ1000, 0.25 to 0.35 N·m; VQ2000, 0.5 to 0.7 N·m.)

### ⚠ Caution

Dust on the sealing surface of the gasket or solenoid valve can cause air leakage.

## Replacement of Cylinder Port Fittings

### ⚠ Caution

The cylinder port fittings are a cassette for easy replacement. The fittings are blocked by a clip inserted from the top of manifold. Remove the clip with a screwdriver to remove fittings.

For replacement, insert the fitting assembly until it strikes against the inside wall and then reinsert the clip to the specified position.

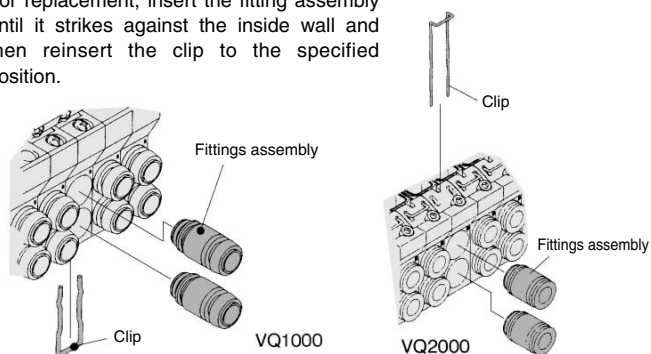

Applicable tubing O.D.	Fitting assembly part no.	
	VQ1000	VQ2000
Applicable tubing ø3.2	VVQ1000-50A-C3	—
Applicable tubing ø4	VVQ1000-50A-C4	VVQ1000-51A-C4
Applicable tubing ø6	VVQ1000-50A-C6	VVQ1000-51A-C6
Applicable tubing ø8	—	VVQ1000-51A-C8
M5	VVQ1000-50A-M5	—

\* Refer to "Option" on pages 2-4-172 to 2-4-173 for other types of fittings.

### ⚠ Caution

1. Use caution that O-rings must be free from scratches and dust. Otherwise, air leakage may result.
2. After screwing in the fittings, mount the M5 fitting assembly on the manifold base. (Tightening torque: 0.8 to 1.2 N·m)
3. Purchasing order is available in units of 10 pieces.

## ⚠ Precautions 2

Be sure to read before handling. For Safety Instructions and Solenoid Valve Precautions, refer to page 2-9-2.

### Mounting/Removing from the DIN Rail

#### ⚠ Caution

##### Removing

1. Loosen the clamp screw on side (a) of the end plate on both sides.
2. Lift side (a) of the manifold base and slide the end plate in the direction of (2) shown in the figure to remove.

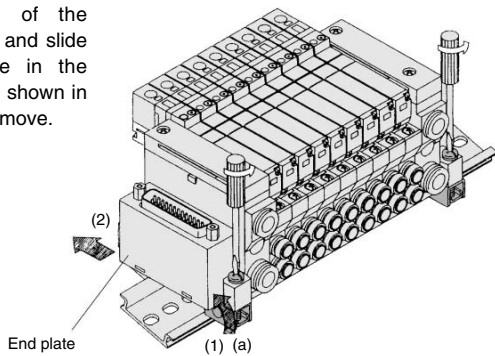

##### Mounting

1. Hook side (b) of the manifold base on the DIN rail.
  2. Press down side (a) and mount the end plate on the DIN rail.
- Tighten the clamp screw on side (a) of the end plate.
- The proper tightening torque for screws is 0.4 to 0.6 N·m.

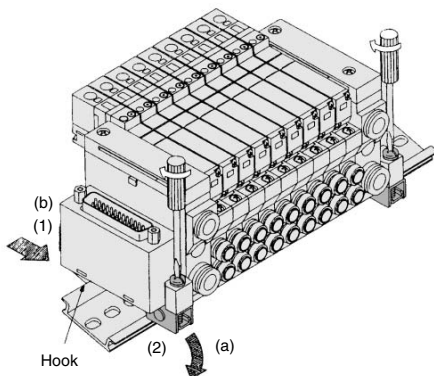

### Enclosure IP65

#### ⚠ Caution

Wires, cables, connectors, etc. used for models conforming to IP65 should also have enclosures equivalent to or of stricter than IP65.

### Built-in Silencer Replacement Element

#### ⚠ Caution

A silencer element is incorporated in the end plate on both sides of the A dirty and choked element may reduce cylinder speed or cause malfunction. Clean or replace the dirty element.

#### Element Part No.

Type	Element part no.	
	VQ1000	VQ2000
Built-in silencer, direct exhaust	VVQ1000-82A-1	VVQ2000-82A-1

\* The minimum order quantity is 10 pcs.

Remove the cover from the top of the end plate and remove the old element with a screwdriver, etc.

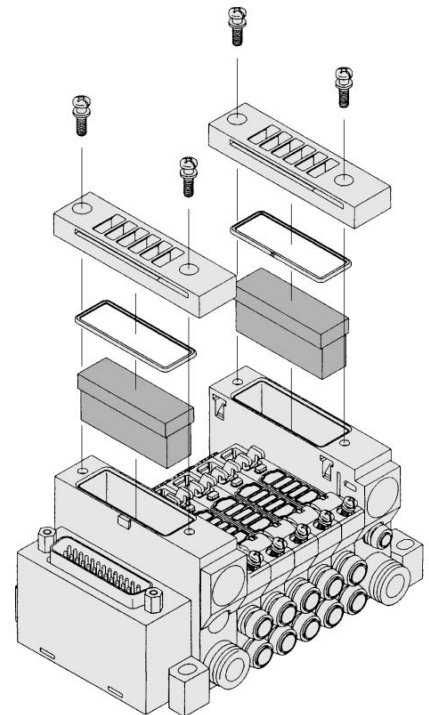

### How to Calculate the Flow Rate

For obtaining the flow rate, refer to pages 2-1-8 to 2-1-11.

Option

Special Wiring Specifications

In the internal wiring of F kit, P kit, J kit, G kit, T kit and S kit, double wiring (connected to SOL. A and SOL. B) is adopted for each station regardless of the valve and option types. Mixed single and double wiring is available as an option.

1. How to Order

Indicate an option symbol “-K”, for the manifold no. and be sure to specify the mounting position and number of stations of the single and double wiring by means of the manifold specification sheet.

Example) **VV5Q11-08C6FU1-D K S**

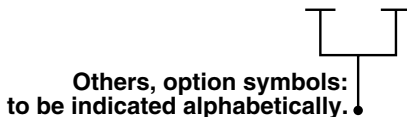

2. Wiring specifications

With the A side solenoid of the 1st station as no.1 (meaning, to be connected to no.1 terminal), without making any terminals vacant.

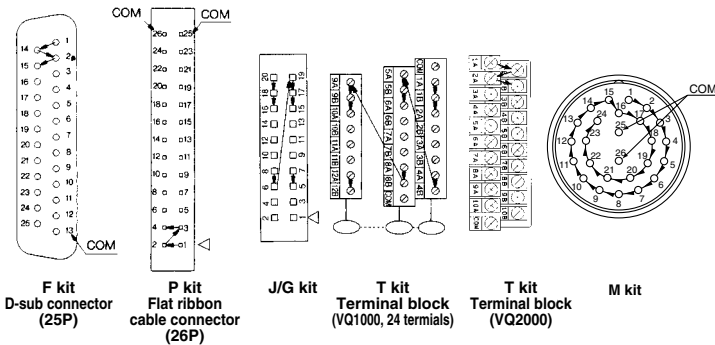

3. Max. number of stations

The maximum number of stations depends upon the number of solenoids. Assuming one for a single and two for a double, determine the number of stations so that the total number is not more than the max. number given in the following table.

Kit	F kit (D-sub connector)		P kit (Flat ribbon cable connector)				J kit (Flat ribbon cable connector)	G kit (Flat ribbon cable with terminal block)
Type	F <sub>S</sub> <sup>U</sup> □ 25P	F <sub>S</sub> <sup>U</sup> A 15P	P <sub>S</sub> <sup>U</sup> □ 26P	P <sub>S</sub> <sup>U</sup> C 20P	P <sub>S</sub> <sup>U</sup> B 16P	P <sub>S</sub> <sup>U</sup> A 10P	J <sub>S</sub> <sup>U</sup> □ 20P	G
Max. points	24	14	24	18	14	8	16	16
Kit	T kit (Terminal block)				S kit (Serial transmission)		M kit (Circular connector)	
Type	2 rows of terminal blocks		3 rows of terminal blocks		S□		M□	
VQ1000	16		24					
Max. points	20				16		24	

Negative Common Specifications

Specify the valve model no. as shown below for negative COM specification. The manifold no. shown below is for the T and L kits. For other kits the standard manifold can be used. For negative COM S or G kit, please contact SMC.

VQ1100 N - 5

• Negative common specifications

How to order negative COM manifold

T kit:

VV5Q11-06 C6 T N - N

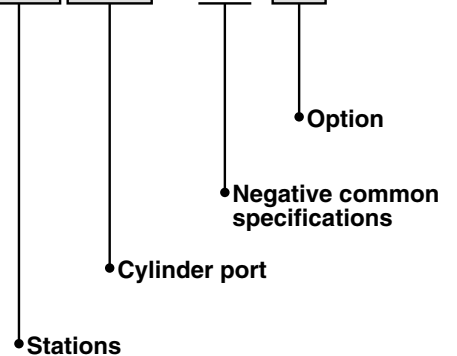

L kit:

VV5Q11-06 C6 L N 1 - N

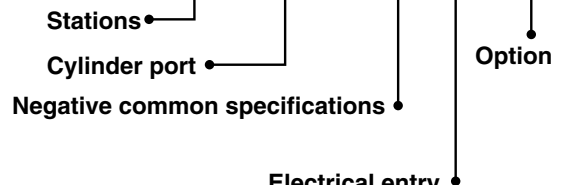

Electrical entry Cable length

0	With cable (0.6 m)
1	With cable (1.5 m)
2	With cable (3 m)



## External Pilot Specifications

When the supply air pressure is lower than the required minimum operating pressure (0.1 to 0.2 MPa) for the solenoid valve (or when the valve is used for vacuum), specify an external pilot model. Order a manifold or valve by suffixing the external pilot specification, "R".

The X-port of the manifold base is equipped with One-touch fittings for external pilot.

VQ1000: C4 (One-touch fitting for ø4)

VQ2000: C6 (One-touch fitting for ø6)

### How to order manifold

**VV5Q11-08C6FU1-R S**

Others, option symbols:  
to be indicated alphabetically.

### How to order valves

**VQ1100 R - 5**

External pilot specifications

Note 1) When low wattage type is also desired, specify as "RY".

Note 2) In this valve pilot exhaust is connected to the EA passage of the manifold. Therefore, it is not possible to supply air from EXH port, nor vacuum from ports other than SUP port.

## Inch-size One-touch Fittings

The valve with inch-size One-touch fittings is shown below.

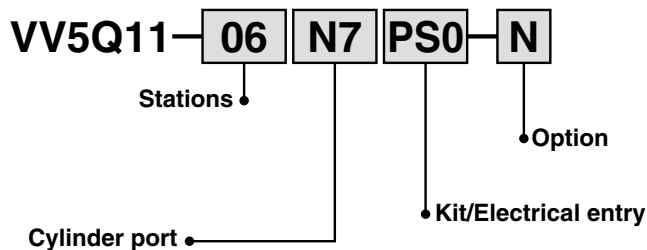

Symbol	N1	N3	N7	N9	M5T	NM
Applicable tubing O.D. (Inch)	ø 1/8"	ø 5/32"	ø 1/4"	ø 5/16"	10-32UNF (M5 thread)	Mixed
4(A), 2(B) port	<b>VQ1000</b>	●	●	—	●	●
	<b>VQ2000</b>	—	●	●	—	●

Note) When inch-size fittings are selected for the cylinder port, use inch size fittings for both P and R port.

1(P), 3(R) port size  
 VQ1000 ..... ø5/16" (N9)  
 VQ2000 ..... ø3/8" (N11)

VQC

SQ

VQ0

VQ4

VQ5

VQZ

VQD

# Series VQ1000/2000

## Option

### DIN Rail Mounting

Each manifold can be mounted on a DIN rail. Order it by indicating a DIN rail mounting option symbol, "-D". In this case, a DIN rail which is approx. 30 mm longer than the manifold with the specified number of stations is attached.

- **When DIN rail is unnecessary**  
(DIN rail mounting brackets only are attached.)  
Indicate the option symbol, "-DO", for the manifold no.

Example)

**VV5Q11-08C6FU1-D0S**

Others, option symbols:  
to be indicated alphabetically.

- **When using DIN rail longer than the manifold with specified number of stations**  
Clearly indicate the necessary number of stations next to the option symbol "-D" for the manifold no.

Example)

**VV5Q11-08C6FU1-D09S**

DIN rail for 9 stations

Others, option symbols:  
to be indicated alphabetically.

- **When changing the manifold style into a DIN rail mounting style.**  
Order brackets for mounting a DIN rail. (Refer to "Option" on pages 2-4-168 and 2-4-173.)

No. VVQ1000-57A (For VQ1000)  
VVQ2000-57A (For VQ2000)  
2 pcs. per one set.

- **When ordering DIN rail only**  
DIN rail no.: AXT100-DR-□

As for □, specify the number from the DIN rail table.  
For L dimension, refer to the dimensions of each kit.

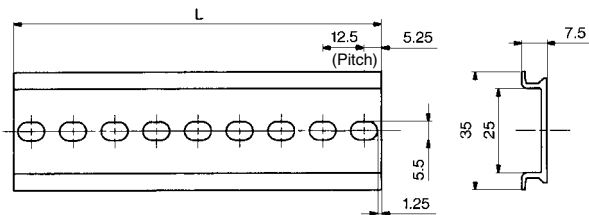

### L Dimension

$$L = 12.5 \times n + 10.5$$

No.	1	2	3	4	5	6	7	8	9	10
L dimension	23	35.5	48	60.5	73	85.5	98	110.5	123	135.5
No.	11	12	13	14	15	16	17	18	19	20
L dimension	148	160.5	173	185.5	198	210.5	223	235.5	248	260.5
No.	21	22	23	24	25	26	27	28	29	30
L dimension	273	285.5	298	310.5	323	335.5	348	360.5	373	385.5
No.	31	32	33	34	35	36	37	38	39	40
L dimension	398	410.5	423	435.5	448	460.5	473	485.5	498	510.5