

# Series VQ1000

## Body Ported

# Plug-in Unit: Flip Type

### How to Order Manifold

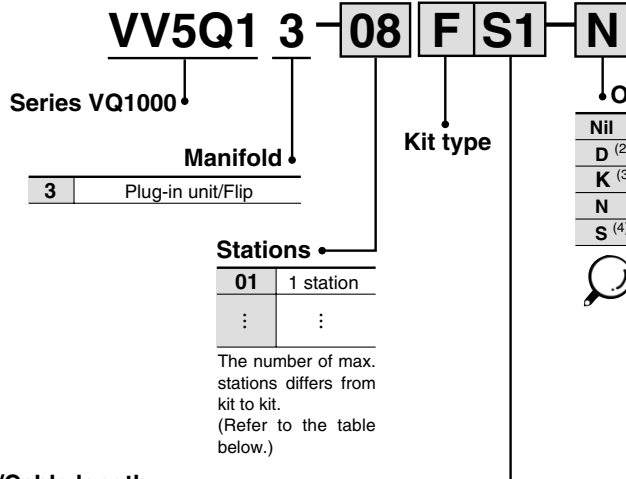

Nil	None
D <sup>(2)</sup>	DIN rail mounting style
K <sup>(3)</sup>	Special wiring specifications (Except double wiring)
N	With name plate
S <sup>(4)</sup>	Built-in silencer, direct exhaust

- Note 1) When two or more symbols are specified, indicate them alphabetically.  
Example) -DNS
- Note 2) All S kits are DIN rail mounting styles, so include suffix "D".
- Note 3) Specify the wiring specifications in the manifold specification sheet. (Except L kit)
- Note 4) F, P and S kits are provided with an exhaust on one side, while L kits are with an exhaust on both sides.

### Kit/Electrical entry/Cable length

#### F kit (D-sub connector)

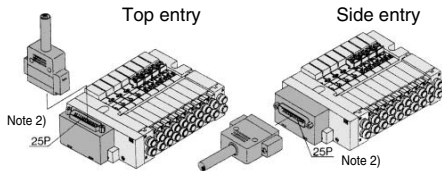

Connector entry direction		P. 2-4-12			
Top entry	Side entry	Kit F	Kit S	Without cable	Max. 16 <sup>(2)</sup> stations
U0	S0	U0	S0	Without cable	Max. 16 <sup>(2)</sup> stations
U1	S1	U1	S1	With cable (1.5 m)	
U2	S2	U2	S2	With cable (3 m)	
U3	S3	U3	S3	With cable (5 m)	

#### P kit (Flat ribbon cable connector)

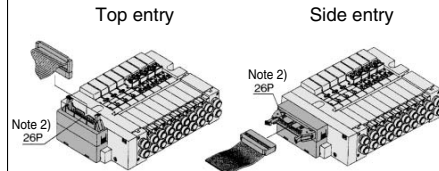

Connector entry direction		P. 2-4-14			
Top entry	Side entry	Kit P	Kit S	Without cable	Max. 16 <sup>(2)</sup> stations
U0	S0	U0	S0	Without cable	Max. 16 <sup>(2)</sup> stations
U1	S1	U1	S1	With cable (1.5 m)	
U2	S2	U2	S2	With cable (3 m)	
U3	S3	U3	S3	With cable (5 m)	

#### J kit (Flat ribbon cable connector)

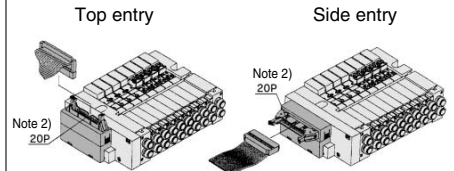

Connector entry direction		P. 2-4-16			
Top entry	Side entry	Kit J	Kit S	Without cable	Max. 16 <sup>(2)</sup> stations
U0	S0	U0	S0	Without cable	Max. 16 <sup>(2)</sup> stations
U1	S1	U1	S1	With cable (1.5 m)	
U2	S2	U2	S2	With cable (3 m)	
U3	S3	U3	S3	With cable (5 m)	

#### L kit (Lead wire cable)

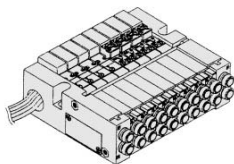

Kit L	Lead wire entry direction		Cable length		Maximum number of stations
	Symbol	Direction	Symbol	Cable length	
D	Entry on D side	0	Without cable	Max. 16 stations	
		1	With cable (0.6 m)		
U	Entry on U side	2	With cable (1.5 m)	Max. 16 stations	
		3	With cable (3.0 m)		

#### S kit (Serial transmission unit)

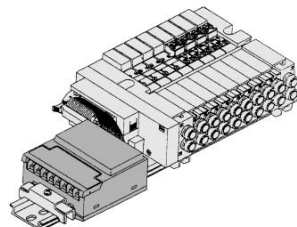

The valve is equipped with an indicator light/surge voltage suppressor, and the voltage is 24 VDC.

The dust-protected type SI unit is applicable, too. For details, please contact SMC.

P. 2-4-20			
Kit S <sup>(3)</sup>	Without SI unit	Without SI unit	Max. 16 <sup>(2)</sup> stations
0	Without SI unit	Without SI unit	Max. 16 <sup>(2)</sup> stations
A	With general type SI unit (Series EX300)	Without SI unit	
B	Mitsubishi Electric Corp.: MELSECNET/MINI-S3 Data Link System	Without SI unit	
C	OMRON Corp.: SYSBUS Wire System	Without SI unit	
D	SHARP Corp.: Satellite I/O Link System	Without SI unit	
F1	NKE Corp.: Uni-wire System (16 output points)	Without SI unit	
H	NKE Corp.: Uni-wire H System	Without SI unit	



Note 1) Besides the above, F and P kits with different number of pins are available. For details, refer to page 2-4-28.

Note 2) For details, refer to page 2-4-29.

Note 3) Please consult with SMC for the following serial transmission kits: Matsushita Electric Works, Ltd.; Rockwell Automation, Inc.; SUNX Corporation; Fuji Electric Co., Ltd.; OMRON Corporation.

### How to Order Valves

**VQ1 1 3 0 Y 5 C6**

**Series VQ1000**  
Type of actuation

1	2 position single	
2	2 position double (Latching)	 Metal seal  Rubber seal
Note) 3	3 position closed center	
Note) 4	3 position exhaust center	
Note) 5	3 position pressure center	

Note) 3 position occupies two stations.

**Seal**

0	Metal seal
1	Rubber seal

Note 1) For negative common specifications, refer to "Option" on page 2-4-29.

**Cylinder ports**

C3	With One-touch fitting for ø3.2
C4	With One-touch fitting for ø4
C6	With One-touch fitting for ø6
M5	M5 thread

Note) For inch-size One-touch fittings, refer to "Option" on page 2-4-29.

**Manual override**

Nil:	Non-locking push type (Tool required)	B: Locking type (Tool required)	C: Locking type (Manual)
------	---------------------------------------	---------------------------------	--------------------------

Manual override on body side

Manual override for pilot valve

Note) A manual override for pilot valve is provided to the standard model for double type. (Refer to page 2-4-26.)

**Light/Surge voltage suppressor**

Nil	Yes
E	None

**Function**

Symbol	Specifications	DC	AC
Nil	Standard type	(1.0 W)	○ <sup>(1)</sup>
H <sup>(2)</sup>	High pressure type	(1.5 W)	—
Y <sup>(2)</sup>	Low wattage type	(0.5 W)	—

Note 1) For power consumption of AC type, refer to page 2-4-10.

Note 2) Except double (latching).

**Coil voltage**

1	100 VAC (50/60 Hz)
2 <sup>Note)</sup>	200 VAC (50/60 Hz)
3	110 VAC (50/60 Hz)
4 <sup>Note)</sup>	220 VAC (50/60 Hz)
5	24 VDC
6	12 VDC

Note) 200/220 VAC models are applicable to the F and L kits.

### How to Order Manifold Assembly

**Example**

Single solenoid (24 VDC)  
VQ1130-5-C6 (4 sets)

Double solenoid (24 VDC)  
VQ1230-5B-C6 (4 sets)

D-sub connector cable

F kit (D-sub connector)

Manifold base (8 stations)  
VV5Q13-08FU2

Cylinder ports  
C6: With One-touch fitting for ø6

VV5Q13-08FU2 ... 1 set (F kit 8 station manifold base no.)  
\*VQ1130-5-C6 ... 4 sets (Single solenoid part no.)  
\*VQ1230-5B-C6 ... 4 sets (Double latching solenoid part no.)

The asterisk denotes the symbol for assembly. Prefix it to the part nos. of the solenoid valve, etc.

Specify the part numbers for valves and options together beneath the manifold base part number. Besides, when the arrangement will be complicated, specify them by means of the manifold specification sheet.

- VQC
- SQ
- VQ0
- VQ4
- VQ5
- VQZ
- VQD

### Manifold Option

P. 2-4-23

#### Blanking plate assembly VVQ1000-10A-3

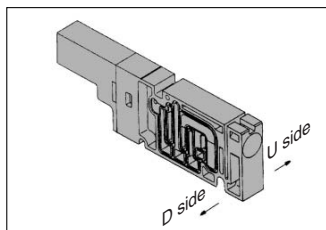

#### Individual SUP spacer VVQ1000-P-3-C6

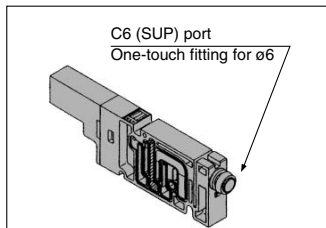

#### Individual EXH spacer VVQ1000-R-3-C6

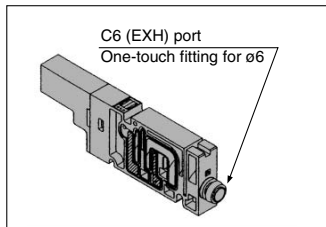

#### Name plate [-N3] VVQ1000-N3-Station (1 to Max. stations)

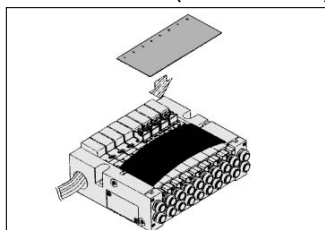

#### Double Check block VQ1000-FPG-□□

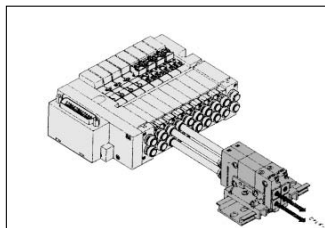

#### DIN rail mounting bracket [-D] VVQ1000-57A-3

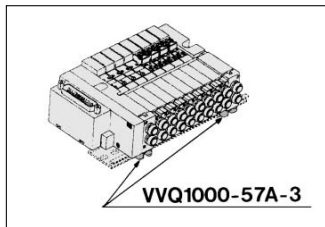

#### Built-in silencer, direct exhaust [-S]

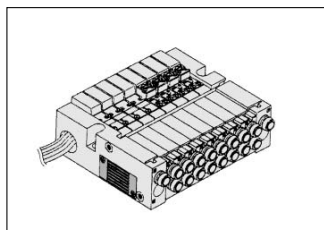

#### Silencer AN103-X233

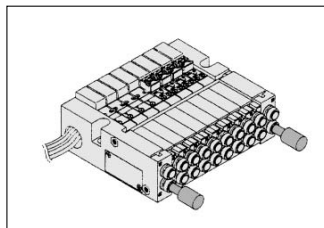

#### Block valve VQ□□□□□□□□□□□□□□□□

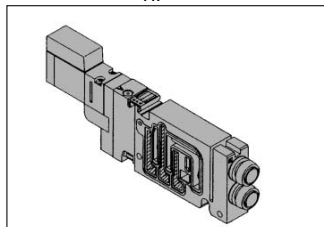

#### Port plug VVQ000-58A

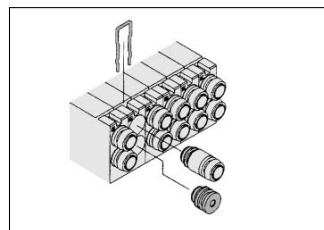

#### Blanking plug KQ2P-<sup>23</sup>/<sub>06</sub>

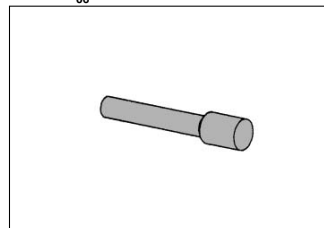

- Refer to page 2-4-27 for cylinder port fitting.
- For replacement parts, refer to page 2-4-103.

## Plug-in Unit: Flip Type Series VQ1000

### Manifold Specifications

Series	Base model	Type of connection	Porting specifications		Applicable <sup>(2)</sup> stations	Applicable solenoid valve	5 station weight (g)	
			Port location	One-touch fitting/Port size <sup>(1)</sup>				
				1 (P), 3 (R)	4 (A), 2 (B)			
VQ1000	VV5Q13-□□□	<ul style="list-style-type: none"> <li>■ F kit—D-sub connector</li> <li>■ P kit—Flat ribbon cable connector</li> <li>■ J kit—Flat ribbon cable connector (20P)</li> <li>■ L kit—Lead wire cable</li> <li>■ S kit—Serial transmission unit</li> </ul>	Side	C6 (ø6) (Option Built-in silencer, Direct exhaust)	C3 (ø3.2) C4 (ø4) C6 (ø6) M5 (M5 thread)	1 to 16 stations	VQ1□30 VQ1□31	424

Note 1) Inch-size One-touch fittings are also available. For details, refer to page 2-4-29.  
 Note 2) For details, refer to page 2-4-29.

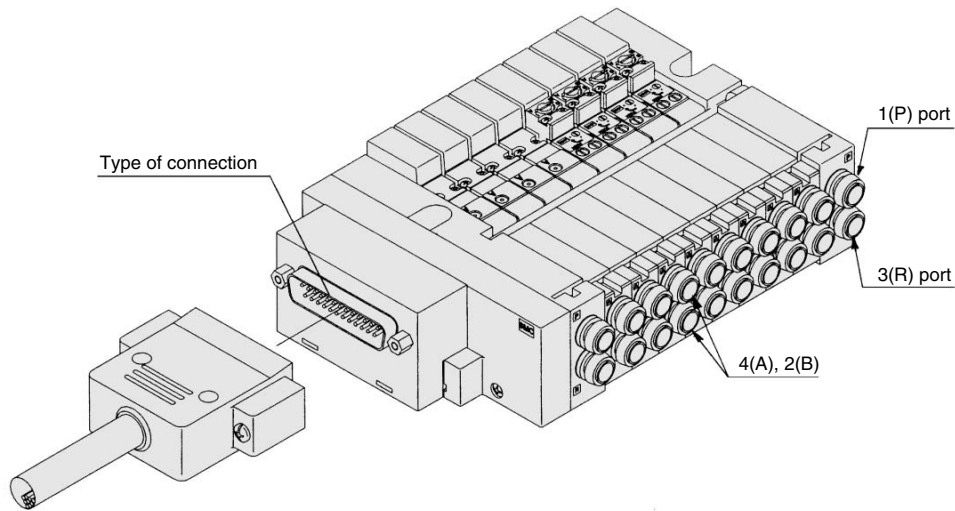

- VQC
- SQ
- VQ0
- VQ4
- VQ5
- VQZ
- VQD

# P VQ1000 Kit (Flat ribbon cable connector)

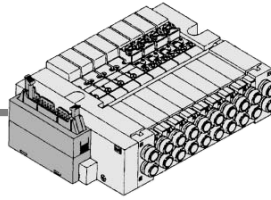

- MIL flat ribbon cable connector reduces installation labor for electrical connection.
- Using the connector for flat ribbon cable (26P), (10P, 16P, 20P as an option) conforming to MIL standard permits the use of connectors put on the market and gives a wide interchangeability.
- Top or side receptacle position can be selected in accordance with the available mounting space.
- Maximum stations are 16.

Series	Porting specifications	Porting specifications		Applicable stations
		Port location	Port size	
VQ1000	Side	C6	1(P), 3(R)	Max. 16 stations
			4(A), 2(B)	

## Flat Ribbon Cable (26 pins)

### Cable assembly

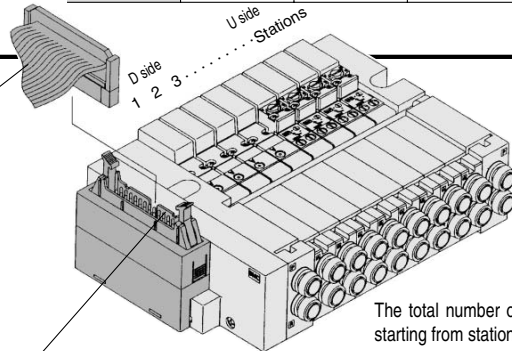

The total number of stations is tabulated starting from station one on the D side.

**AXT100-FC26-<sup>1</sup>/<sub>2</sub>/<sub>3</sub>**

( Flat ribbon cable connector assembly can be ordered individually or included in a specific manifold model no. Refer to How to Order Manifold.

**Flat Ribbon Cable Connector Assembly (Option)**

Cable length (L)	Assembly part no.	Note
1.5 m	AXT100-FC26-1	Cable 26 core x 28AWG
3 m	AXT100-FC26-2	
5 m	AXT100-FC26-3	

\* For other commercial connectors, use a 26 pins type with strain relief conforming to MIL-C-83503.

**Connector manufacturers' example**

- Sumitomo 3M Limited
- Fujitsu Limited
- Japan Aviation Electronics Industry, Ltd.
- J.S.T. Mfg. Co., Ltd.
- Oki Electric Cable Co., Ltd.

Note) Types with 10, 16, or 20 pin are also available. For details, refer to page 2-4-28.

### Electrical wiring specifications

Flat ribbon cable connector	Terminal no.	Polarity
1 station {	SOLA 1	(-)
	SOLB 2	(+)
	SOLA 3	(+)
2 stations {	SOLB 4	(+)
	SOLA 5	(+)
3 stations {	SOLB 6	(+)
	SOLA 7	(+)
4 stations {	SOLB 8	(+)
	SOLA 9	(+)
5 stations {	SOLB 10	(+)
	SOLA 11	(+)
6 stations {	SOLB 12	(+)
	SOLA 13	(+)
7 stations {	SOLB 14	(+)
	SOLA 15	(+)
8 stations {	SOLB 16	(+)
	SOLA 17	(+)
9 stations {	SOLB 18	(+)
	SOLA 19	(+)
10 stations {	SOLB 20	(+)
	SOLA 21	(+)
11 stations {	SOLB 22	(+)
	SOLA 23	(+)
12 stations {	SOLB 24	(+)
	COM. 25	(-)
	COM. 26	(+)

Triangle mark indicator position

As the standard electrical wiring specifications, double wiring (connected to SOL. A and SOL. B) is adopted for the internal wiring of each station for 12 stations or less, regardless of valve and option types. Mixed single and double wiring is available as an option.

Terminal no.	1	2	3	4	5	6	7	8	9	10
SOL	A	B	A	B	A	B	A	B	A	B
Stations	1	2	3	4	5					

The places of asterisk are not used. Double wiring (Standard)

Note) When using the negative common specifications, use valves for negative common. (Refer to page 2-4-29.)

## How to Order Manifold

**VV5Q1 3-08 P S 1-N**

**Series VQ1000**

**Manifold**

3 Plug-in unit/Flip

**Stations**

01	1 station
⋮	⋮
16	16 stations

Note) For details, refer to page 2-4-29.

**Cable (Length)**

0	Without cable
1	With cable (1.5 m)
2	With cable (3 m)
3	With cable (5 m)

**Connector entry direction**

U	Top entry
S	Side entry

**Option**

Nil	None
D	DIN rail mounting style
K <sup>(2)</sup>	Special wiring specifications (Except double wiring)
N	With name plate
S	Built-in silencer, direct exhaust (U side only)

Note 1) When two or more symbols are specified, indicate them alphabetically. Example) -DNS

Note 2) Specify the wiring specifications on the manifold specification sheet.

# Plug-in Unit: Flip Type Series VQ1000

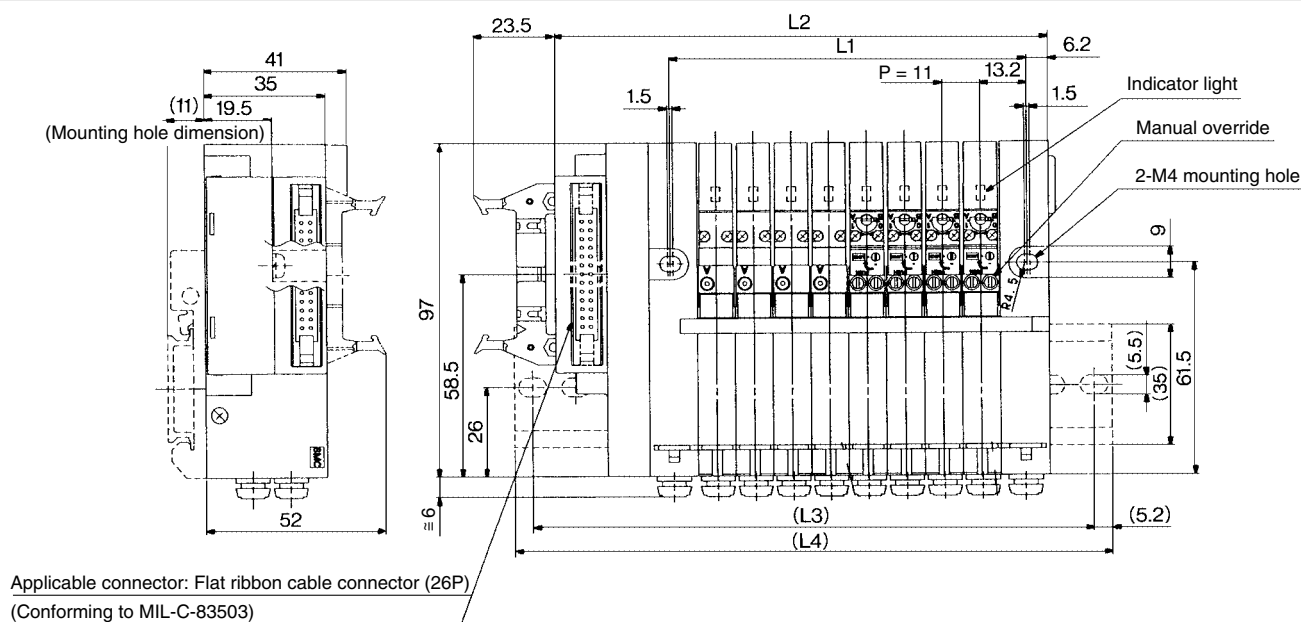

- VQC
- SQ
- VQ0
- VQ4
- VQ5
- VQZ
- VQD

The broken lines indicate the DIN rail mounting style [-D] and the top entry connection [-PU].  
**Note** 3 position types need two stations.  
 Cylinder port is located at U side of body.

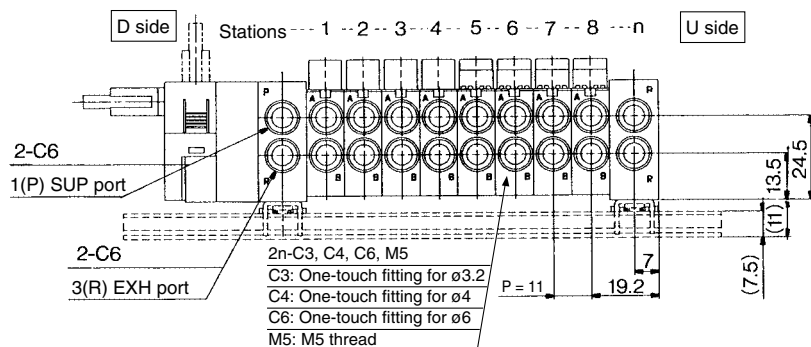

### Dimensions

Formula L1 = 11n + 15.5, L2 = 11n + 55 n: Station (Maximum 16 stations)

L \ n	1	2	3	4	5	6	7	8	9	10	11	12	13	14	15	16
L1	26.5	37.5	48.5	59.5	70.5	81.5	92.5	103.5	114.5	125.5	136.5	147.5	158.5	169.5	180.5	191.5
L2	66	77	88	99	110	121	132	143	154	165	176	187	198	209	220	231
(L3)	87.5	100	112.5	125	137.5	150	162.5	175	187.5	200	212.5	225	237.5	250	262.5	275
(L4)	98	110.5	123	135.5	148	160.5	173	173	185.5	198	210.5	223	235.5	248	260.5	273

### How to Order Valves

**VQ1 1 3 0 Y 5 C6**

#### Series VQ1000 Type of actuation

1	2 position single
2	2 position double (Latching)
3 <sup>Note</sup>	3 position closed center
4 <sup>Note</sup>	3 position exhaust center
5 <sup>Note</sup>	3 position pressure center

Note) 3 position types need two stations. **Seal**

0	Metal seal
1	Rubber seal

Note) For negative common specifications, refer to "Option" on page 2-4-29.

#### Function

Symbol	Specifications	DC	AC
Nil	Standard type	(1.0 W)	○ <sup>(1)</sup>
H <sup>(2)</sup>	High pressure type	(1.5 W)	—
Y <sup>(2)</sup>	Low wattage type	(0.5 W)	—

Note 1) For power consumption of AC type, refer to page 2-4-10.  
 Note 2) Except double (latching).

#### Cylinder port

C3	With One-touch fitting for ø3.2
C4	With One-touch fitting for ø4
C6	With One-touch fitting for ø6
M5	M5 thread

Note) For inch-size One-touch fittings, refer to "Option" on page 2-4-29.

#### Manual override

Nil	Non-locking push type (Tool required)
B	Locking type (Tool required)
C	Locking type (Manual)

Note) A manual override for pilot valve is provided to the standard model for double type.

#### Coil voltage

1	100 VAC (50/60 Hz)
3	110 VAC (50/60 Hz)
5	24 VDC
6	12 VDC

#### Light/ Surge voltage suppressor

Nil	Yes
E	None

### How to Order Manifold Assembly

Specify the part numbers for valves and options together beneath the manifold base part number.

<Example>

Flat ribbon cable kit with 3 m cable  
 VV5Q13-08PU2.... 1 set — Manifold base no.  
 \*VQ1130-5-C6.... 4 sets — Valve part no. (Stations 1 to 4)  
 \*VQ1230-5B-C6... 4 sets — Valve part no. (Stations 5 to 8)

Prefix the asterisk to the part nos. of the solenoid valve, etc. Write sequentially from the 1st station on the D side. When part nos. written collectively are complicated, specify by using the manifold specification sheet.

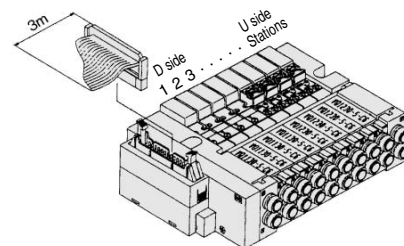

## Manifold Option Parts

### Blanking plate assembly VVQ1000-10A-3

It is used when a blanking plate is mounted to a manifold in advance for possible valve mounting, etc.

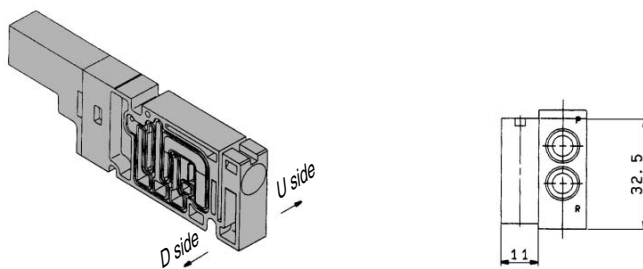

### Individual SUP spacer VVQ1000-P-3-C6

When the same manifold is to be used for different pressures, individual SUP spacers are used as SUP ports for different pressures. (One station space is occupied.)

Since the SUP passage on the spacer's D side is blocked in advance, it is mounted on the D side of the valve U side. (Refer to the application example.)

\* Specify the spacer mounting position and SUP block plate mounting position on the manifold specification sheet.

\* Electric wiring is connected to the position of the manifold station where the individual SUP spacer is mounted.

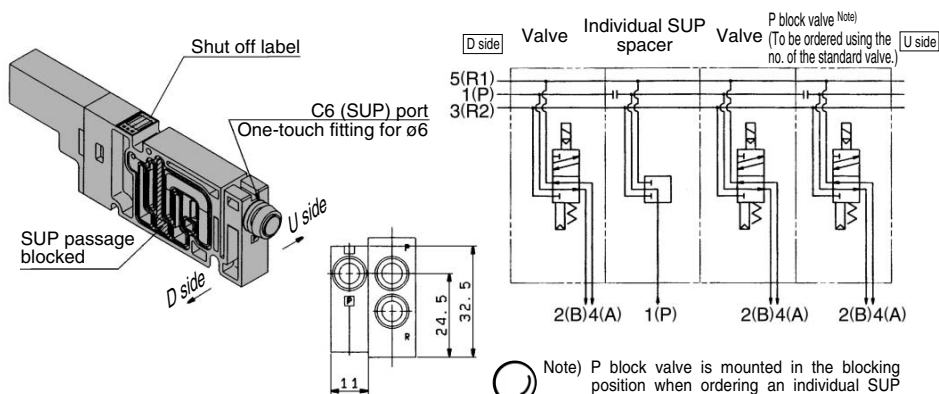

Note) P block valve is mounted in the blocking position when ordering an individual SUP spacer incorporated with a manifold. When separately ordering an individual SUP spacer, separately order a R block valve.

### Individual EXH spacer VVQ1000-R-3-C6

When valve exhaust affects other stations due to the circuit configuration, this spacer is used for individual valve exhaust. (1 station space is occupied.)

Since the EXH passage on the spacer's D side is blocked in advance, it is mounted on the D side of the valve for individual supply while blocking the valves U side. (Refer to the application example.)

\* Specify the spacer mounting position and EXH block plate mounting position on the manifold specification sheet.

\* Electric wiring is connected to the position of the manifold station where the individual EXH spacer is mounted.

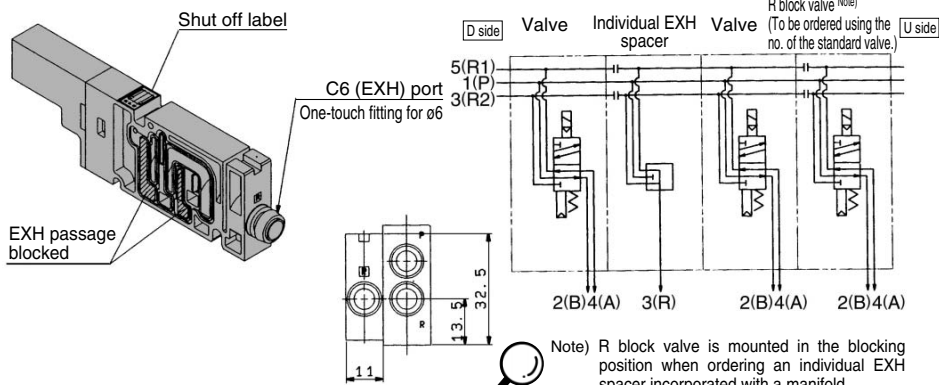

Note) R block valve is mounted in the blocking position when ordering an individual EXH spacer incorporated with a manifold. When separately ordering an individual EXH spacer, separately order a R block valve.

### P R Block valve VQ1<sub>2</sub>3<sub>1</sub><sup>0</sup>-□-□-□-□-<sub>PR</sub>

For a flip plug-in unit, block plate is built in the valve for blocking SUP and EXH passages. Since the no. is classified by the passage to be blocked, specify it by attaching the option no. to the valve no. The block valve is constructed so that D sides of SUP and EXH passages are blocked.

\* Specify the number of stations on the manifold specification sheet.

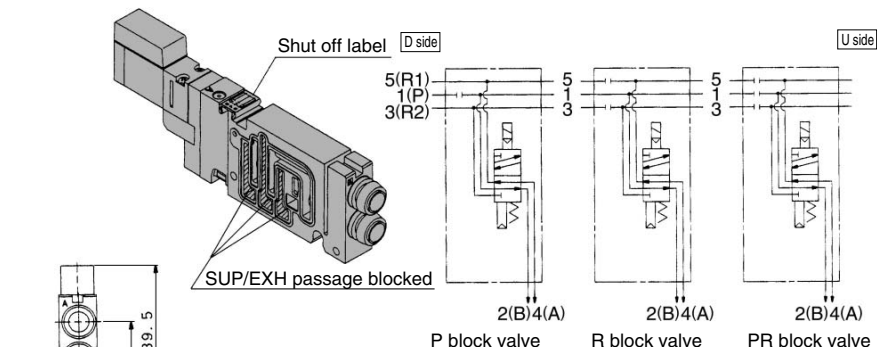

#### <Shut off label>

When using block plates for SUP, EXH passage, indication label for confirmation of the blocking position from outside is attached. (One label for each)

\* When ordering a block plate incorporated with the manifold no., a block indication label is attached to the manifold.

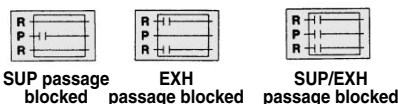

For SUP passage block	VQ1 <sub>2</sub> 3 <sub>1</sub> <sup>0</sup> -□-□-□-□- <sub>P</sub>
For EXH passage block	VQ1 <sub>2</sub> 3 <sub>1</sub> <sup>0</sup> -□-□-□-□- <sub>R</sub>
For SUP/EXH passage block	VQ1 <sub>2</sub> 3 <sub>1</sub> <sup>0</sup> -□-□-□-□- <sub>PR</sub>

VQC

SQ

VQ0

VQ4

VQ5

VQZ

VQD

# Series VQ1000

## Manifold Option Parts

### Name plate [-N3]

#### VVQ1000-N3-Station (1 to Max. stations)

It is a transparent resin plate for placing a label that indicates solenoid valve function, etc. Insert it into the groove on the side of the end plate and bend it as shown in the figure.

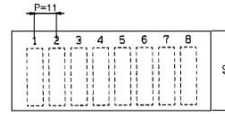
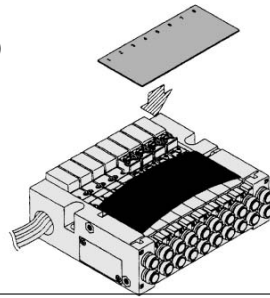

\* When ordering assemblies incorporated with a manifold, add suffix N to the manifold no.

### Blanking plug

#### KQ2P-<sup>23</sup>/<sub>04</sub>/<sub>06</sub>

It is inserted into an unused cylinder port and SUP/EXH ports. Purchasing order is available in units of 10 pieces.

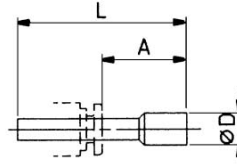
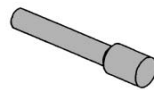

### Dimensions

Applicable fittings size ød	Model	A	L	D
3.2	KQ2P-23	16	31.5	5
4	KQ2P-04	16	32	6
6	KQ2P-06	18	35	8

### DIN rail mounting bracket VVQ1000-57A-3

It is used for mounting a manifold on a DIN rail. The DIN rail mounted bracket is fixed to the manifold end. (The specification is the same as that for the option "-D".)  
1 set of DIN rail mounting bracket is used for 1 manifold (2 DIN rail mounting brackets).

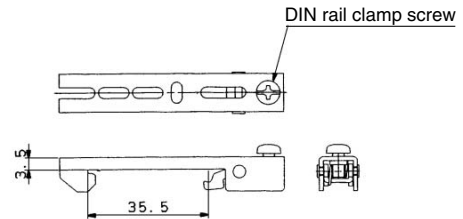
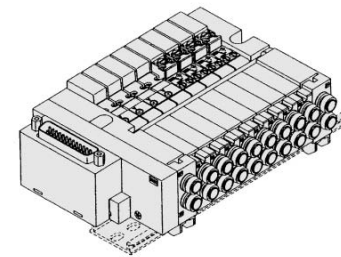

\* When ordering assemblies incorporated with a manifold, add suffix -D to the manifold no.

### Built-in silencer, Direct exhaust [-S]

This is an exhaust port on top of the manifold end plate. The built-in silencer exhibits an excellent noise suppression effect. F, P and S kits are provided with single exhaust on U side.

Note) A large quantity of drainage generated in the air.

• For maintenance, refer to page 2-4-27.

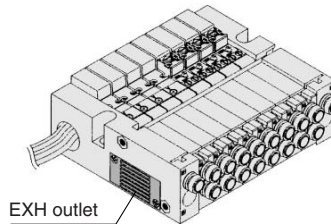

\* When ordering assemblies incorporated with a manifold, add suffix -S to the manifold no.

### Silencer AN103-X233

This is inserted into the centralized type EXH port (One-touch fitting).

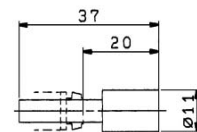
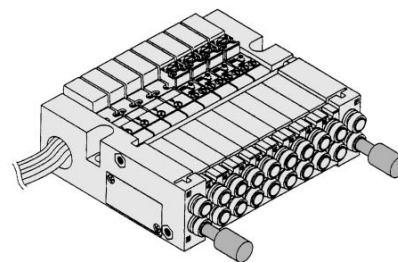

### Dimensions

Series	Applicable fittings size ød	Model	A	L	D	Effective area (mm <sup>2</sup> )	Noise reduction (dB)
VQ1000	6	AN103-X233	20	37	11	7	25

### Port plug VVQ0000-58A

The plug is used to block the cylinder port when using a 4 port valve as a 3 port valve. When ordering it incorporated with a manifold, suffix A or B, the symbol of the plug port, to the valve no.

Example) VQ1130-5L-C6-A  
A port, Plug

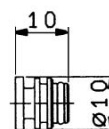
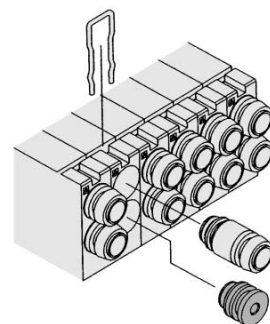





## ⚠ Precautions

**Be sure to read before handling. For Safety Instructions and Solenoid Valve Precautions, refer to page 2-9-2.**

### Light/Surge Voltage Suppressor

#### ⚠ Caution

The lighting positions are concentrated on one side for both single solenoid and double (latching) type. In the double (latching) type, A side and B side energization are indicated by two colors which match the colors of the manual overrides.

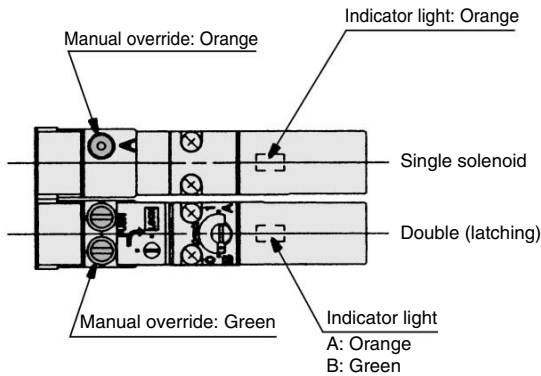

#### DC type circuit diagram

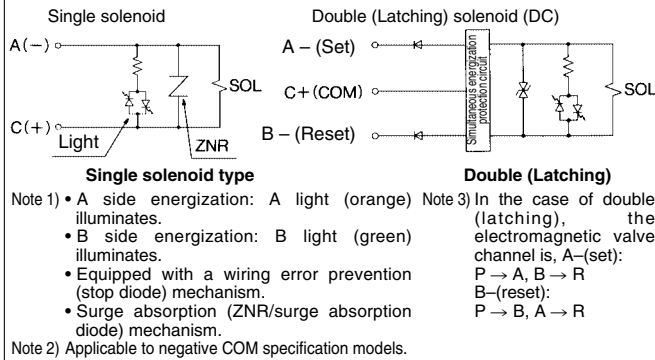

### Double (Latching solenoid) Type

#### ⚠ Caution

Different from the conventional double solenoid, the double uses a latching (self-holding system) solenoid. Although the appearance is the same as the single solenoid, it is constructed so that the movable iron core in the solenoid is held in the ON position on A and B sides by instantaneous energization (20 ms or more). The usage and function is the same as the double solenoid.

#### <Special Cautions for Latching Solenoid>

1. Select the circuit in which ON and OFF signals are not energized simultaneously.
2. 20 ms energization time is necessary for self-holding.
3. Avoid using the latching solenoid valves in environments where impact or collisions with the valve might occur. Also, do not use in places where strong magnetic fields are present.
4. Even though the armature in the solenoid of this valve is held on to B side, ON position (Reset), verify either A side, ON position or B side, ON position by energizing prior to use. After manual operation, the main valve will return to its original position.
5. Manual override on the pilot valve side can retain its switching position after manipulation.
6. Please contact SMC for long-term energization applications.
7. If the metal seal type goes down below the minimum operating pressure of supply air (0.1 MPa or less), the main valve will get back the home position (B side ON position). Therefore, in the event of shutting the supply air or applying the air with being A side ON position remained, cylinder may be pulsated. In the event of manipulating the supply air, the valve's switching position has to be set in the home position side (B side ON position side).

### How to Mount/Remove Solenoid Valve

#### ⚠ Caution

#### <Procedure>

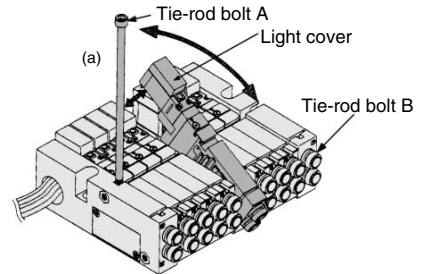

#### How to remove

1. Loosen tie-rod bolt B. (Two to four turns)
2. After fully loosening the tie-rod bolt, take off bolt A upward as shown above.
3. Slide the valves aside to make a 1 mm clearance between the valve to be taken off and the others. As shown above, remove the whole valve while holding up the (a) side.

#### Mounting

Reverse the sequence of steps above to remount. Torque applied to tie-rod bolt should be 1.0 to 1.4 N·m. Tighten evenly.

Note) Be careful not to push on the light cover while mounting/removing the valve.

### Manual Override

#### ⚠ Warning

Without an electric signal for the solenoid valve the manual override is used for switching the main valve.

#### ■ Push type (Tool required)

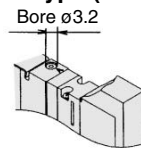

Push down on the manual override button with a small screwdriver until it stops. Release the screwdriver and the manual override will return.

#### ■ Locking slotted type

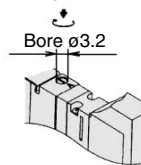

Push down completely on the manual override button with a small screwdriver. While down, turn clockwise 90° to lock it.

#### ■ Locking lever type (Option)

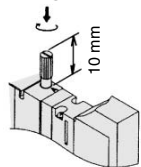

Push down completely on the manual override button with a small screwdriver. While down, turn clockwise 90° to lock it. Turn it counterclockwise to release it.

#### ■ Manual override for double (latching) type

In the case of a double (latching) type, a manual override is provided not only on the body side but to the pilot as a standard. After manual operation, the main valve of the manual on the body side returns to the position before the manual operation, however, the pilot valve manual override maintains the change-over position.

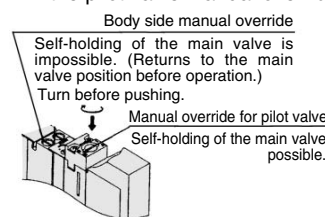

- If the manual override is turned by 180° clockwise and the ► mark is adjusted to A, then pushed in the direction of an arrow (➡), it will be back to the reset condition. (passage P → A)
- If the manual override is turned by 180° counterclockwise and the ► mark is adjusted to B, then pushed in the direction of an arrow (➡), it will be back to the reset condition. (passage P → B) (It is in the reset state at the time of shipment.)

#### ⚠ Caution

Do not apply excessive torque when turning the locking type manual override. (0.1 N·m or less)

## Plug-in Unit: Flip Type Series VQ1000

### Replacement of Cylinder Port Fittings

#### ⚠ Caution

The cylinder port fittings are a cassette for easy replacement. The fittings are blocked by a clip inserted from the top of the valve.

Remove the clip with a screwdriver to remove fittings. For replacement, insert the fitting assembly until it strikes against the inside wall and then re-insert the clip to the specified position.

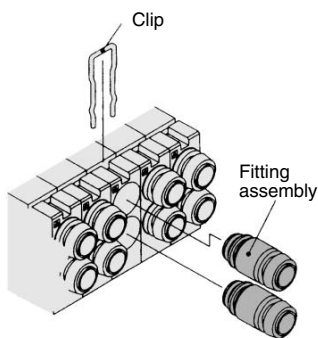

Applicable tubing O.D.	Fitting assembly part no.
	<b>VQ1000</b>
Applicable tubing $\phi 3.2$	VVQ1000-50A-C3
Applicable tubing $\phi 4$	VVQ1000-50A-C4
Applicable tubing $\phi 6$	VVQ1000-50A-C6

Purchasing order is available in units of 10 pieces.

#### Caution

1. Use caution that O-rings must be free from scratches and dust. Otherwise, air leakage may result.
2. The tightening torque for inserting fittings to the M5 thread assembly should be 0.8 to 1.4 N·m.

### Mounting/Removing from the DIN Rail

#### ⚠ Caution

##### Removing

1. Loosen the clamp screw of the end plate on both sides.
2. Lift side (a) of the manifold base and side the end plate in the direction of (2) shown in the figure to remove.

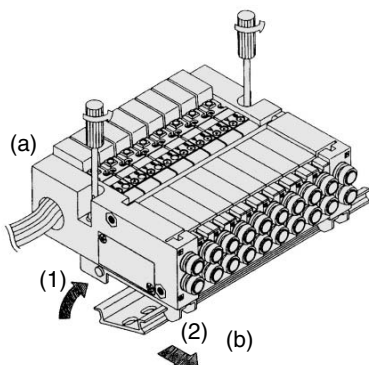

##### Mounting

1. Hook side (b) of the manifold base on the DIN rail.
2. Press down side (a) and mount the end plate on the DIN rail. Tighten the clamp screw on side (a) of the end plate. The proper tightening torque for screws is 0.4 to 0.6 N·m.

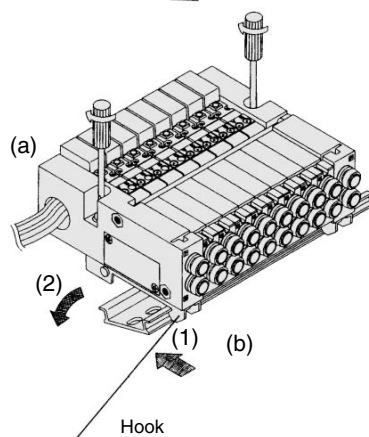

### Built-in Silencer Replacement Element

#### ⚠ Caution

A silencer element is incorporated in the end plate on both sides of the base. A dirty and choked element may reduce cylinder speed or cause malfunction. Clean or replace the dirty element.

#### Element Part No.

Type	Element part no.
	<b>VQ1000</b>
Built-in silencer, direct exhaust (-S)	VVQ1000-82A-3

\* The minimum order quantity is 10 pcs.

Remove the cover from the side of the end plate and remove the old element with a screwdriver, etc.

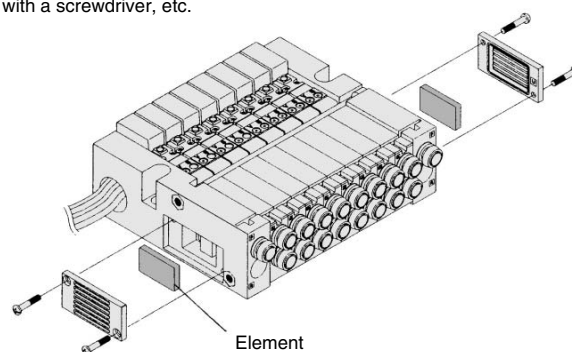

VQC

SQ

VQ0

VQ4

VQ5

VQZ

VQD

### How to Calculate the Flow Rate

For obtaining the flow rate, refer to pages 2-1-8 to 2-1-11.

Series VQ1000

Option

Different Number of Connector Pins

F and P kits with the following number of pins are available. Besides the standard number (F = 25; P = 26) select the desired number of pins and cable length from the cable assembly list. Place an order for the cable assembly separately.

**F** kit (D-sub connector) 15 pins

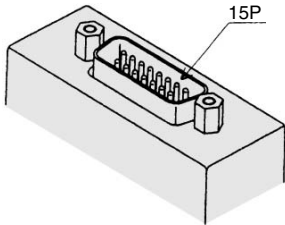

How to order manifold

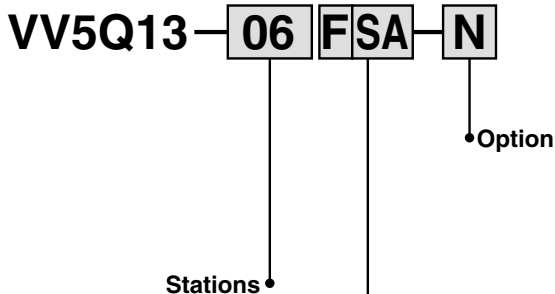

**How to Order**  
 D-sub connector, 15 pins  
 Connector location—Side (horizontal)  
 Without cable

Kit/Electrical entry

Pins	Location	Top entry		Side entry	
		Kit F	UA	Kit F	SA
15P (Max. 7 stations)					

Wiring Specifications

\* As in the case of 25-pin models (standard), terminal no. 1 is the first station SOL.A and the terminal no. 8 is COM.

Wire Color by Terminal No. of D-sub Connector Cable Assembly

Terminal no.	Lead wire color	Dot marking
1	Black	None
2	Brown	None
3	Red	None
4	Orange	None
5	Yellow	None
6	Pink	None
7	Blue	None
8	Purple	White
9	Gray	Black
10	White	Black
11	White	Red
12	Yellow	Red
13	Orange	Red
14	Yellow	Black
15	Pink	Black

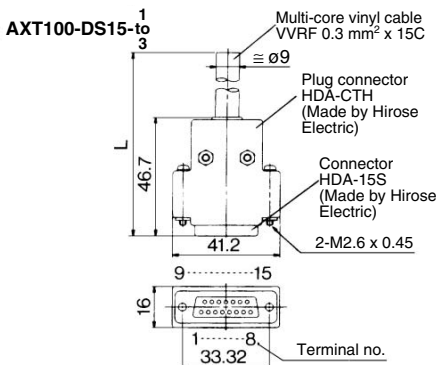

D-sub Connector Cable Assembly

Cable length (L)	Pins	15P	
		Kit F	UA
1.5 m		AXT100-DS15-1	
3 m		AXT100-DS15-2	
5 m		AXT100-DS15-3	

\* For other commercial connectors, use a type conforming to MIL-C-24308.

**P** kit (Flat ribbon cable connector) 10 pins, 16 pins, 20 pins

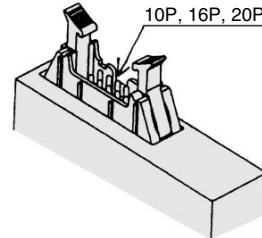

How to order manifold

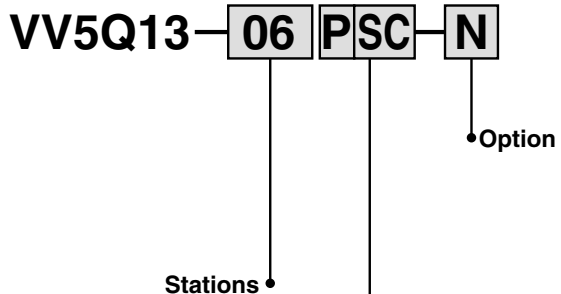

**How to Order**  
 Flat ribbon cable, 20 pins  
 Connector location—Side (horizontal)  
 Without cable

Kit/Electrical entry

Pins	Location	Top entry		Side entry	
		Kit P	UA	Kit P	SA
10P (Max. 4 stations)					
16P (Max. 7 stations)			UB		SB
20P (Max. 9 stations)			UC		SC

Wiring Specifications

\* As in the case of 26-pin models (standard), terminal no. 1 is the first station SOL.A and the last two terminal numbers are used for COM.

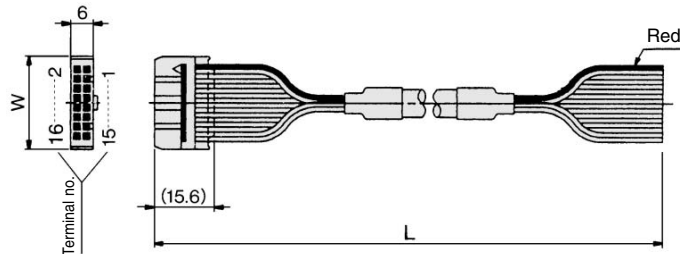

Flat Ribbon Cable Assembly

Cable length (L)	Pins	10P	16P	20P
		1.5 m	AXT100-FC10-1	AXT100-FC16-1
3 m		AXT100-FC10-2	AXT100-FC16-2	AXT100-FC20-2
5 m		AXT100-FC10-3	AXT100-FC16-3	AXT100-FC20-3
Connector width (W)		17.2	24.8	30

\* For other commercial connectors, use a type with strain relief that conform to MIL-C-83503.

Option

Special Wiring Specifications

In the internal wiring of F kit, P kit, and JS kit, double wiring (connected to SOL. A and SOL. B) is adopted for each station regardless of the valve and option types.

Mixed single and double wiring is available as an option.

1. How to order valves

Indicate an option symbol, -K, for the manifold no. and be sure to specify the mounting position and number of stations of the single and double wiring by means of the manifold specification sheet.

Example)

VV5Q13-09FS0-D K S

Others, option symbols: to be indicated alphabetically.

2. Wiring specifications

Connector terminal numbers are connected from solenoid station 1 on the A side in the order indicated by the arrows without shipping any terminal numbers.

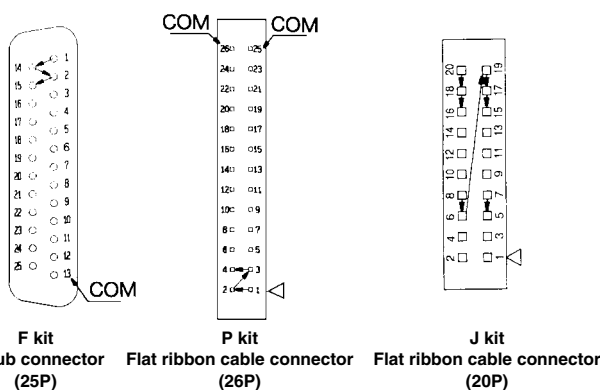

3. Max. number of stations

The maximum number of stations depends upon the number of solenoids. Assuming one for a single and two for a double, determine the number of stations so that the total number is not more than the maximum number given in the following table.

kit	F kit (D-sub connector)		P kit (Flat ribbon cable connector)				J kit (Flat ribbon cable connector)	S kit (Serial)
Type	F <sub>S</sub> □ 25P	F <sub>S</sub> A 15P	P <sub>S</sub> □ 26P	P <sub>S</sub> C 20P	P <sub>S</sub> B 16P	P <sub>S</sub> A 10P	J <sub>S</sub> □ 20P	S □
Max. points	24 16 (stations)	14	24 16 (stations)	18 16 (stations)	14	8	16	16

Negative Common Specifications

Specify the valve model no. as shown below for negative COM specification. The manifold no. shown below is for the L kits. For other kits the standard manifold can be used. Please contact for negative COM S kit.

How to order negative COM valves

VQ1130 N-5-C6

Negative common specifications

How to order negative COM manifold

L kit:

VV5Q13-08 L N D 1 N

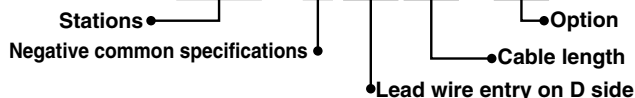

Inch-size One-touch Fittings

Refer to following model no. for inch-size One-touch fittings.

How to order manifold

VV5Q13-08FSO-DN-00T

1(P), 3(R) port size: ø1/4"

How to order valves

VQ1130-5-N7

Cylinder ports

Symbol	N1	N3	N7
Applicable tube O.D. (Inch)	ø1/8"	ø5/32"	ø1/4"

DIN Rail Mounting

Each manifold can be mounted on a DIN rail.

Order it by indicating an option symbol for DIN rail mounting style, -D. In this case, a DIN rail which is approx. 30 mm longer than the manifold with the specified number of stations is attached. Besides, it is also available in the following cases.

When DIN rail is unnecessary (Except S kit)

(DIN rail mounting brackets only are attached.)

Indicate the option symbol, -DO, for the manifold no.

Example)

VV5Q13-08LD1-DOS

Others, option symbols: to be indicated alphabetically.

When using DIN rail longer than the manifold with specified number of stations

Clearly indicate the necessary number of stations next to the option symbol, -D, for the manifold no.

Example)

VV5Q13-08FS1-D09S

DIN rail for 9 stations

Others, option symbols: to be indicated alphabetically.

When changing the manifold style into a DIN rail mount

Order brackets for mounting a DIN rail. (Refer to "Option" on page 2-4-24.)

No. VVQ1000-57A-3 2 pcs. per one

When ordering DIN rail only

DIN rail no.: AXT100-DR-n

\* Refer to the DIN rail dimension table for determining the length.

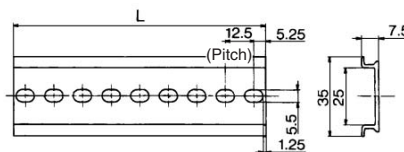

L Dimension

L = 12.5 x n + 10.5

No.	1	2	3	4	5	6	7	8	9	10
L dimension	23	35.5	48	60.5	73	85.5	98	110.5	123	135.5
No.	11	12	13	14	15	16	17	18	19	20
L dimension	148	160.5	173	185.5	198	210.5	223	235.5	248	260.5
No.	21	22	23	24	25	26	27	28	29	30
L dimension	273	285.5	298	310.5	323	335.5	348	360.5	373	385.5
No.	31	32	33	34	35	36	37	38	39	40
L dimension	398	410.5	423	435.5	448	460.5	473	485.5	498	510.5

# Exploded View of Manifold

## VQ1000 (VV5Q13)/Plug-in Unit, Flip Type

(F, P, J, L, S kit)

\* For how to increase the stations, refer to the instruction manual.

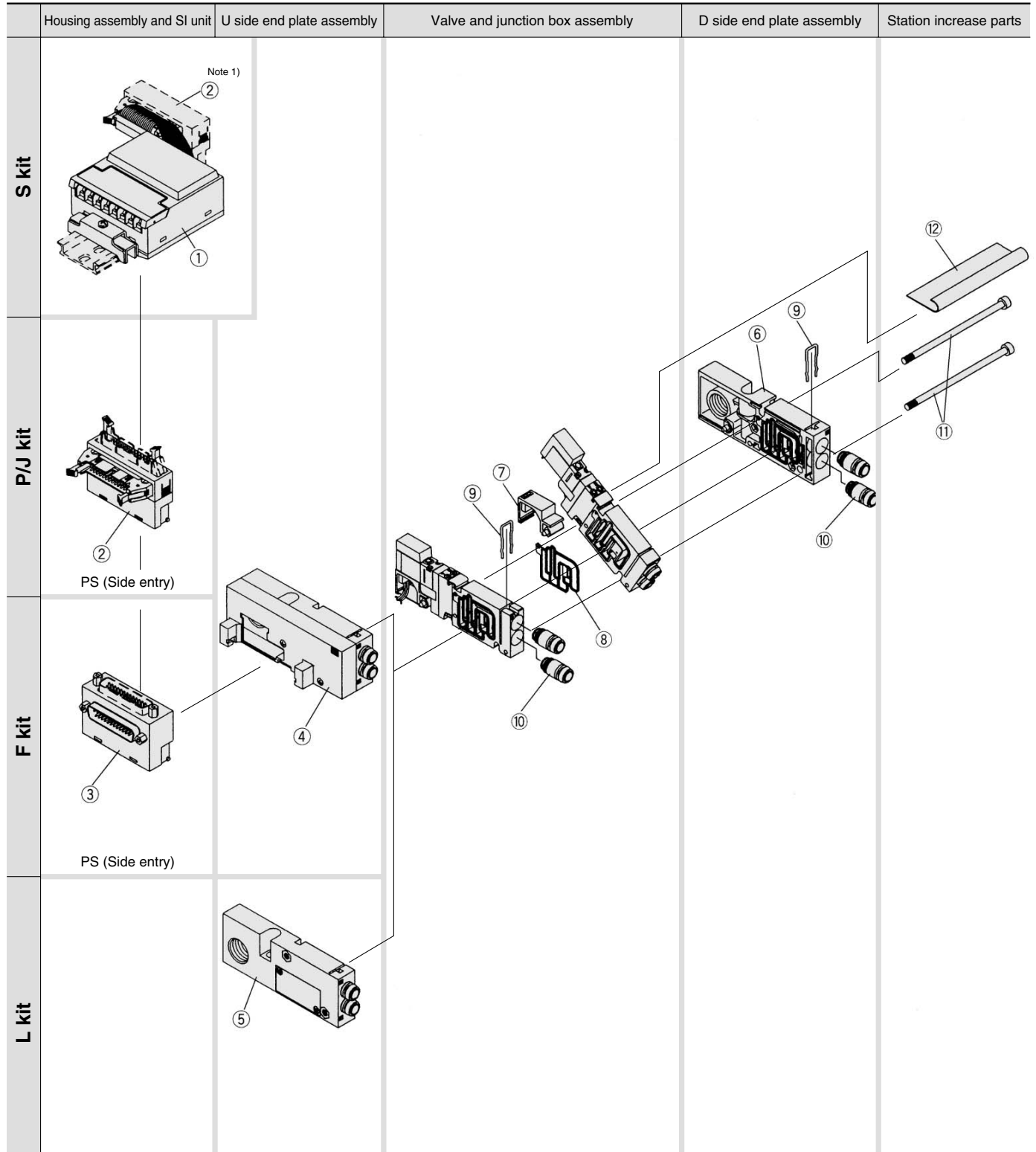

Note 1) S kit is composed of a flat ribbon cable housing assembly (AXT100-1-PU20) of ① SI unit and ② P kit (20 pins).

## <Housing Assembly and SI Unit>

Housing assembly and SI unit no.

No.	Manifold	Part no.	Description
①	(SA kit)	EX330-S001	General type SI unit (Series EX300)
	(SB kit)	EX130-SMB1	SI unit for MELSECNET/MINI-S3 Data Link System (Mitsubishi Electric Corporation)
	(SC kit)	EX130-STA1	SI unit for SYSBUS Wire System (OMRON Corporation)
	(SD kit)	EX130-SSH1	SI unit for Satellite I/O Link System (SHARP Corporation)
	(SF1 kit)	EX130-SUW1	SI unit for 16 point Uni-wire System (NKE Corporation)
	(SH kit)	EX130-SUH1	SI unit for 16 point Uni-wire H System (NKE Corporation)
②	P <sub>S</sub> <sup>U</sup> kit	AXT100-1-P <sub>S</sub> <sup>U</sup> □ <sup>(2)</sup>	Flat cable housing assembly □ = Number of pins: 26, 20, 16, 10
	J <sub>S</sub> <sup>U</sup> kit	AXT100-1-J <sub>S</sub> <sup>U</sup> 20 <sup>(2)</sup>	Flat cable housing assembly
③	F <sub>S</sub> <sup>U</sup> kit	AXT100-1-F <sub>S</sub> <sup>U</sup> □ <sup>(2)</sup>	D-sub connector housing assembly □ = Number of pins: 25, 15



Note 1) S kit is composed of a flat ribbon cable housing assembly (AXT100-1-PU20) of ① SI unit and ② P kit (20 pins).  
Place an order for AXT-100-1-PS20 separately.

Note 2) Top/vertical entry connector for FU and PU while side (horizontal) entry connector for FS and PS.

## <D Side End Plate Assembly>

④⑤ D side end plate assembly no.

VVQ1000-3A-3-□-□

### Option

Nil: Common exhaust  
S: Built-in silencer, direct exhaust<sup>(1)</sup>

### Electrical entry

F: For F kit  
P: For P kit  
J: For J kit  
L: For L kit  
S: For S kit



Note 1) Applicable for L kit only

Note 2) The housing assembly and SI unit of F/P/J/S kit are not included.  
Separately place an order for ①, ②, and ③.

Note 3) The ⑩'s fitting assembly is included.

## <U Side End Plate Assembly No.>

⑥ U side end plate assembly no.

VVQ1000-2A-3-□

### Option

Nil: Common exhaust  
S: Built-in silencer, direct exhaust



Note) The ⑩'s fitting assembly is included.

## <Junction Box Assembly>

⑦ Junction box assembly no.

VVQ1000-1A-3-□

### Electrical entry

F1: For F kit  
P1: P, G, T, S kit for 1 to 12 stations/Double wiring  
P2: G, S kit for 13 to 16 stations/Double wiring  
P3: G, S kit for 1 to 16 stations/Single wiring  
L0□: L0 kit<sup>(Note)</sup>  
L1□: L1 kit<sup>(Note)</sup>  
L2□: L2 kit<sup>(Note)</sup> } □: Stations (1 to 16)



Note) Lead wire assembly for extensions is attached.

## <Replacement Parts>

No.	Part no.	Description	Material	Number
⑧	VVQ1000-80A-3-2	Seal	HNBR	12
⑨	VVQ1000-80A-4	Clip	Stainless steel	12



Note) A set of parts containing 12 pcs. each is enclosed.

## <Fittings Assembly>

⑩ Fittings assembly part no.

VVQ1000-50A-□

### Port size

C3: Applicable tubing ø3.2  
C4: Applicable tubing ø4  
C6: Applicable tubing ø6<sup>(1)</sup>



Note 1) Standard SUP/EXH port is C6.

Note 2) Purchasing order is available in units of 10 pieces.

## <Station Increase Parts>

\* The station can be increased up to 2 stations.

No. <sup>(3)</sup>	Part no.	Description	Material	Number <sup>(1)</sup>
⑪	VVQ1000-105A-3-□ <sup>(2)</sup>	Tie-rod bolt	Carbon steel	2
⑫		Junction cover	Stainless steel	1



Note 1) Each number of replacement parts are included in one set.

Note 2) □: Number of stations (01 to 16)

Note 3) ⑪ and ⑫ are in one set.

VQC

SQ

VQ0

VQ4

VQ5

VQZ

VQD