

2 Port Solenoid Valve/Air Operated Valve For Dust Collector

CE*
* [Excluding VXFC]

RoHS

UK
CA

Applicable for
high temperature

Fluid temperature
100 °C

Large port sizes
available.

Port size
50A to 100A

Enclosure

IP65*

* Electrical entry
"Flat" type
terminal is IP40.

Faston terminal
type added

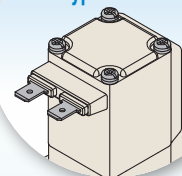

Flange type

Mounting can be changed
according to the piping
conditions!

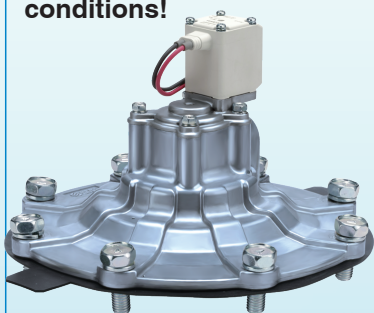

Flange body type

Orifice machining on the outlet is not required,
so piping man hour is reduced!

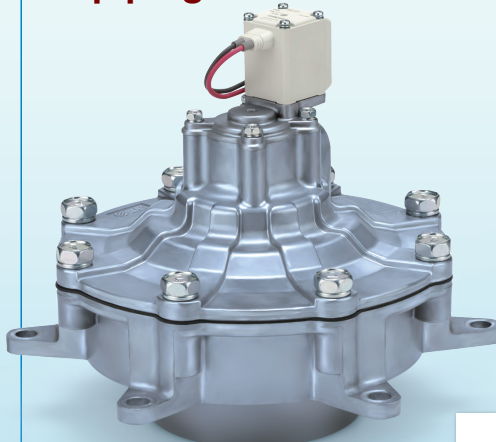

Flange body I type
(Flange mounting type)

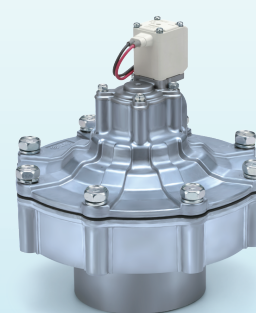

Flange body II type
(Through hole mounting type)

Installation Example

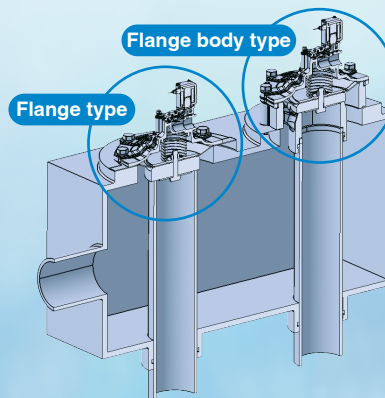

Direct piping type

Solenoid valve
type



Air operated
type

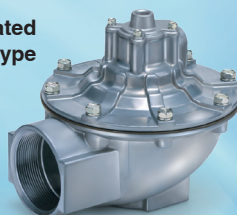

Variations

Dedicated controller for operation
VXFC Series

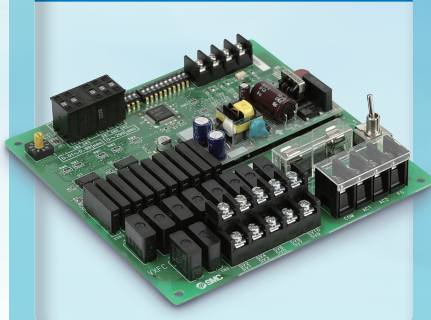

Type	Port size	Piping				Electrical entry*
		Direct piping type	Flange type	Flange body I type Flange mounting type	Flange body II type Through hole mounting type	
Solenoid valve type	20A	●				Grommet DIN terminal Conduit terminal Conduit Flat terminal
	25A	●				
	40A	●				
	50A	●				
Air operated type	65A	●	●			
	80A	●	●	●	●	
	90A		●			
	90A		●			
	100A		●			

VXF2/VXFA2 Series



CAT.EUS70-47Ba-UK

Enclosure
IP65

With/without
silencer
(Can be selected.)

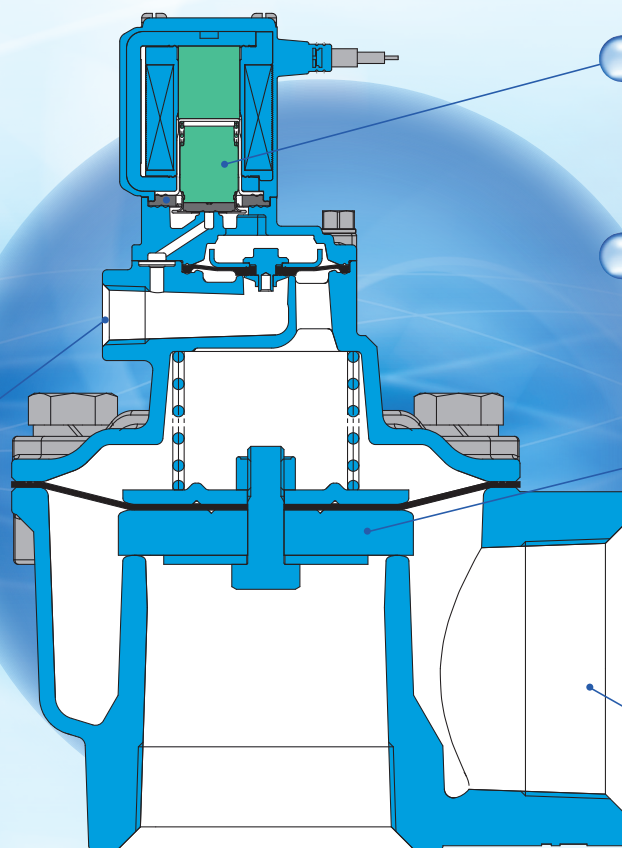
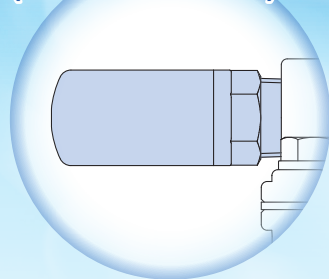

Improved armature
durability

Flame resistant
UL94V-0 conformed

Diaphragm
assembly material
(Diaphragm/Main valve)
• NBR/POM:
For normal temperature
• FKM/PTFE:
For high temperature

Piping variations
20A, 25A, 40A
50A, 65A, 80A
90A, 100A

Built-in full-wave rectifier type (AC specification)

- Improved durability
Service life is extended by the special construction. (compared with current shading coil)
- Reduced apparent power (for normal temperature)
11 VA → **7 VA** (Size 21, 22, 24, 25, 26, 27, 28)
18 VA → **10 VA** (Size 23)

- Noise reduction
Rectified to DC by a full-wave rectifier, resulting in a buzz noise reduction.

Solenoid Valve Type VXF2 Series

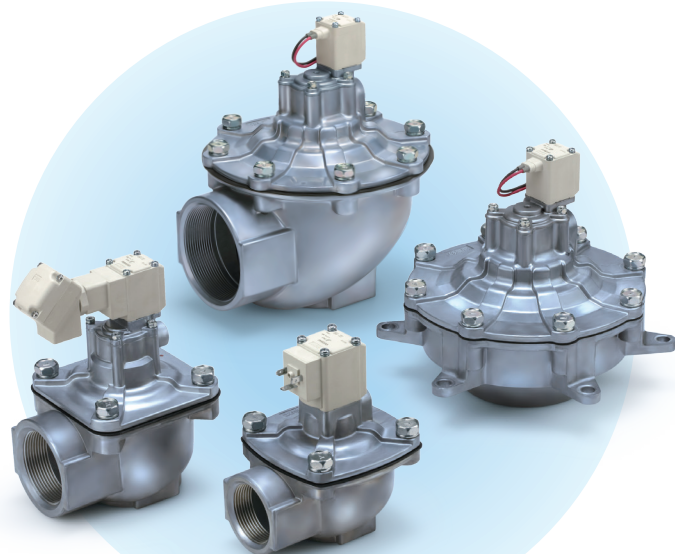

Air Operated Type VXFA2 Series

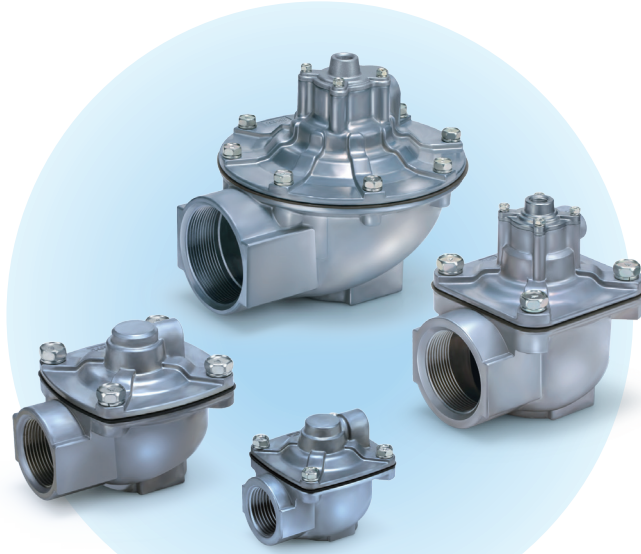

The valve controller turns ON/OFF multiple valves for the dust controller.

Power supply voltage 85 to 240 VAC
24 VDC to 48 VDC

Number of outputs 6 outputs,
10 outputs

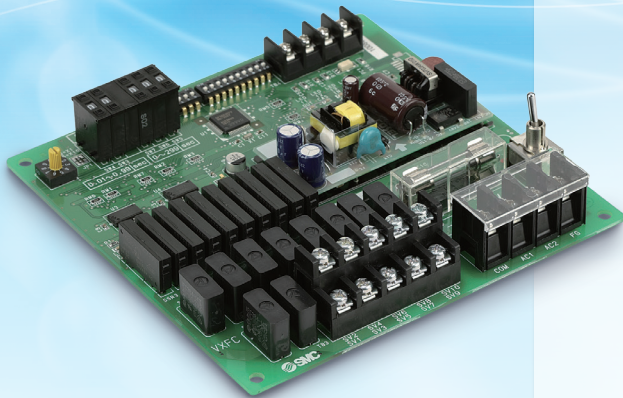

Application example

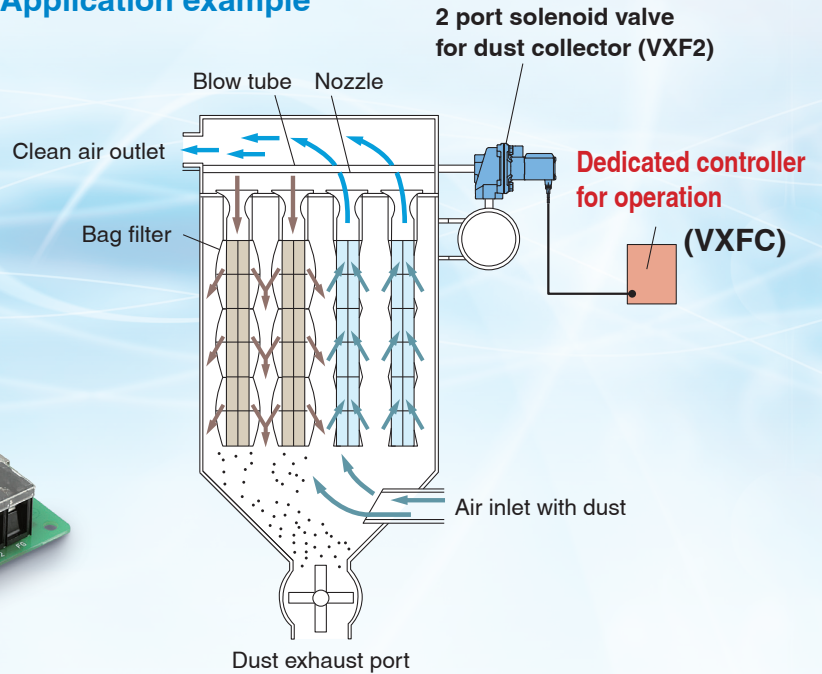

Two-time Hitting Function

A two-time hitting function is adopted to improve the bag filter dusting efficiency. Turn ON the DIP switch dual pulse (OFF for one-time hitting). (Effective up to the number of setting channels)

Operation sequence diagram

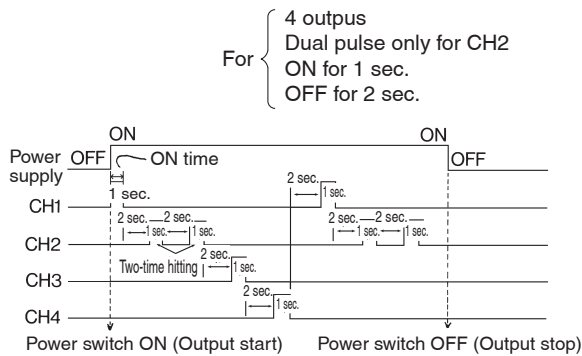

Interrupt Operation Function

Interrupting an operation from an external switch is possible using input signals.

Operation sequence diagram

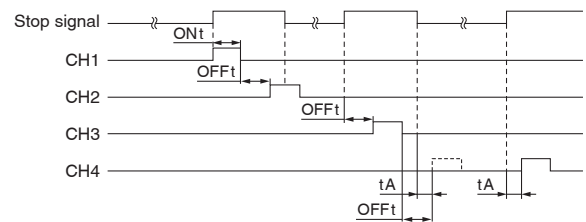

Cascade Connection (Multiple-board connection)

VXFC10: One board allows outputs at merely 10 output points max. But the points can be increased to 20 and 30 output points by connecting cascades.

Connection

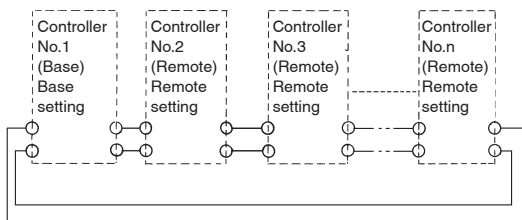

Operation sequence diagram

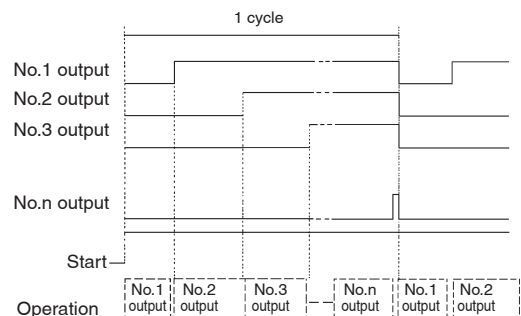

VXF2 Series Solenoid Valve Type

Common Specifications/Selection Steps

Specifications

Solenoid Valve Type

Model	VXF21A□□	VXF22A□□	VXF23A□□	VXF24A□□	VXF25A□□	VXF26 ^A _B _C _D □□	VXF27B□□	VXF28B□□
Orifice size mm ϕ	22	28	44	53	70	80	90	100
Fluid	Air							
Min. operating pressure MPa	0.03				0.1			
Max. operating pressure MPa	0.7							
Fluid temperature (for normal/high temperature) °C	-10 (No freezing) to 60/-10 (No freezing) to 100							
Ambient temperature °C	-10 to 60							
Operating environment	Indoor							
Coil insulation type (for normal/high temperature)	Class B/Class H							
Enclosure	IP65 ^{Note)}							
Allowable voltage fluctuation V	$\pm 10\%$ of rated voltage							
Apparent power (for normal/high temperature) AC (VA)	7/9		10/12		7/9			
Power consumption (for normal temperature) DC (W)	7		8		7			

Note 1) For enclosure, refer to "Glossary of Terms" on page 36.

Note 2) Be sure to read "Specific Product Precautions" and "2-Port Solenoid Valve for Fluid Control Precautions" before handling.

Solenoid Coil Specifications

Normally Closed (N.C.)

DC Specification (For normal temperature)

Size	Power consumption [W] ^{Note 1)}	Temperature rise [°C] ^{Note 2)}
Size 21, 22, 24, 25, 26, 27, 28	7	60
Size 23	8	55

Note 1) Power consumption, Apparent power: The value at ambient temperature of 20 °C and when the rated voltage is applied. (Variation: $\pm 10\%$)

Note 2) Value at ambient temperature of 20 °C and when the rated voltage is applied. The value depends on the ambient environment. This is for reference.

AC Specification (Built-in Full-wave Rectifier Type) (For normal/high temperature)

Size	Apparent power [VA] ^{Note 1) Note 2)}	Temperature rise [°C] ^{Note 3)}
Size 21, 22, 24, 25, 26, 27, 28	7/9	60/100
Size 23	10/12	70/100

Note 1) Power consumption, Apparent power: The value at ambient temperature of 20 °C and when the rated voltage is applied. (Variation: $\pm 10\%$)

Note 2) There is no difference in the frequency and the inrush and energised apparent power because a rectifying circuit is used in the AC (Built-in full-wave rectifier type).

Note 3) Value at ambient temperature of 20 °C and when the rated voltage is applied. The value depends on the ambient environment. This is for reference.

Valve Leakage Rate

	Leakage rate ^{Note)}
Internal leakage	1000 cm ³ /min or less
External leakage	100 cm ³ /min or less

Note) Leakage value at an ambient temperature of 20 °C with 0.5 MPa of pressure applied. The amount of valve leakage may be greater if operated at a pressure lower than 0.3 MPa.

Selection Steps

Step 1 Select the port size.

Item	Selection item	Symbol
Port size	20A (3/4)	1
	25A (1)	2
	40A (1 1/2)	3
	50A (2)	4
	65A (2 1/2)	5
	80A (3)	6
	90A (2 1/2)	7
	100A (4)	8



Step 2 Select the piping system.

Item	Selection item	Symbol
Piping	Direct piping type	A
	Flange type	B
	Flange body I type	C
	Flange body II type	D



Step 3 Diaphragm/Main valve material, Select whether the silencer is mounted.

Item	Selection item	Symbol
Material With/without silencer	NBR/POM Without silencer	A
	NBR/POM With silencer	B
	FKM/PTFE Without silencer	C
	FKM/PTFE With silencer	D



Step 4 Select electrical specification.

Item	Voltage/Electrical entry	Symbol
Electrical specification	Grommet 24 VDC	A



Step 5 For other special options, refer to page 7.



How to Order

Solenoid Valve Type **VXF2 1 A A A**

Port size		Piping	
Symbol	Port size	Symbol	Piping
1	20A	A	Direct piping type
2	25A		
3	40A		
4	50A		
5	65A	A	Direct piping type
		B	Flange type
6	80A	A	Direct piping type
		B	Flange type
		C	Flange body I type
		D	Flange body II type
7	90A	B	Flange type
8	100A		

Material – With/without silencer, Fluid temperature

Symbol	Diaphragm/Main valve material	With/without silencer	Fluid temperature
A	NBR/POM	Without	For normal temperature (Max. 60 °C)
B	NBR/POM	With	
C	FKM/PTFE	Without	For high temperature* (Max. 100 °C)
D	FKM/PTFE	With	

* For high temperature type, DC specification, DIN terminal and flat terminal are not available.

Voltage – Electrical entry

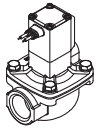
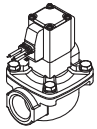
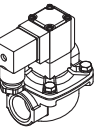
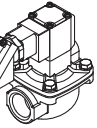
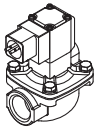
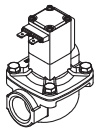
Symbol	Voltage	Electrical entry
A	24 VDC	Grommet 
B	100 VAC	Grommet ^{Note 2)} (with surge voltage suppressor) 
C	110 VAC	
D	200 VAC	
E	230 VAC	
F	24 VDC	DIN terminal (with surge voltage suppressor) 
G	24 VDC	
H	100 VAC	
J	110 VAC	
K	200 VAC	Conduit terminal (with surge voltage suppressor) 
L	230 VAC	
M	24 VDC	
N	100 VAC	
P	110 VAC	Conduit ^{Note 2)} (with surge voltage suppressor) 
Q	200 VAC	
R	230 VAC	
S	24 VDC	
T	100 VAC	Flat terminal 
U	110 VAC	
V	200 VAC	
W	230 VAC	
Y	24 VDC	
Z		Other voltages

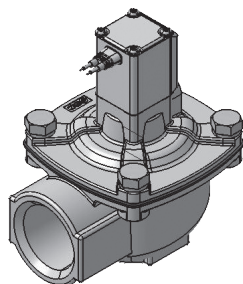

A: Direct piping type

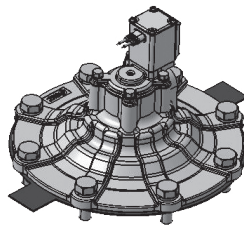

B: Flange type

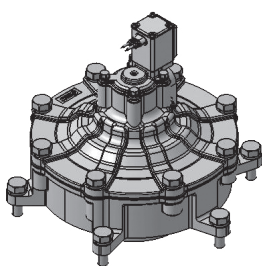

C: Flange body I type (Flange mounting type)

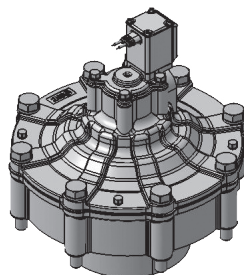

D: Flange body II type (Through hole mounting type)

Symbol

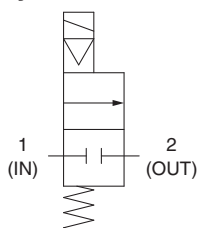

Refer to "Glossary of Terms" on page 36 for symbol.

Note 1) For high temperature type, DC specification, DIN terminal and flat terminal are not available.

Note 2) For high temperature type, the surge voltage suppressor for grommet or conduit is attached in the middle of lead wire.

For other special options, refer to page 7.

Special voltage	24 VAC
	48 VAC
	220 VAC
	240 VAC
	12 VDC
DIN terminal with light	
With conduit terminal and light	
G thread ^{Note 3)}	
NPT thread ^{Note 3)}	

Note 3) For options with silencer, the exhaust port is Rc.

Series VXFA2 Air Operated Type

Common Specifications/Selection Steps

Specifications

Air Operated Type

Model	VXFA21AA□	VXFA22AA□	VXFA23AA□	VXFA24AA ^A □	VXFA25(A,B) ^A □	VXFA26(A,B,C,D) ^A □	VXFA27B ^A □	VXFA28B ^A □
Orifice size [mmφ]	22	28	44	53	70	80	90	100
Port size	3/4	1	1 1/2	2	2 1/2	3	3 1/2	4
Fluid	Air							
Min. operating pressure [MPa]	0.03				0.1			
Max. operating pressure [MPa]	0.7							
Fluid temperature (for normal/high temperature) [°C]	-10 (No freezing) to 60/-10 (No freezing) to 100							
Ambient temperature [°C]	5 to 60							
Operating environment	Indoor/Outdoor							

Note) For outdoor use, be sure to implement sufficient measures to protect the operational pilot valve against rain water. Refer to the "2-Port Solenoid Valves for Fluid Control Precautions" for protective measures.

Valve Leakage Rate

	Leakage rate ^{Note)}
Internal leakage	1000 cm ³ /min or less
External leakage	100 cm ³ /min or less

Note) Leakage is the value at ambient temperature 20 °C.

Selection Steps

Step 1 Select the port size.

Item	Selection item	Symbol
Port size	20A(3/4)	1
	25A(1)	2
	40A(1 1/2)	3
	50A(2)	4
	65A(2 1/2)	5
	80A(3)	6
	90A(2 1/2)	7
	100A(4)	8

VXFA2 ^q 1 A A

Step 2 Select the piping system.

Item	Selection item	Symbol
Piping	Direct piping type	A
	Flange type	B
	Flange body I type	C
	Flange body II type	D

VXFA2 1 ^w A A

Step 3 Diaphragm/Main valve material, Select whether the silencer is mounted.

Item	Selection item	Symbol
Material With/without silencer	NBR/POM Without silencer	A
	NBR/POM With silencer	B
	FKM/PTFE Without silencer	C
	FKM/PTFE With silencer	D

VXFA2 1 A ^e A

Step 4 For other special options, refer to page 7.

How to Order

Air Operated Type **VXFA2 1 A A**

Port size		Piping	
Symbol	Port size	Symbol	Piping
1	20A	A	Direct piping type
2	25A		
3	40A		
4	50A		
5	65A	A	Direct piping type
		B	Flange type
6	80A	A	Direct piping type
		B	Flange type
		C	Flange body I type
		D	Flange body II type
7	90A	B	Flange type
8	100A		

Material – With/without silencer, Fluid temperature

Symbol	Diaphragm/ Main valve material	With/without silencer*	Fluid temperature
A	NBR/POM	Without	For normal temperature (Max. 60 °C)
B	NBR/POM	With	
C	FKM/PTFE	Without	For high temperature (Max. 100 °C)
D	FKM/PTFE	With	

* For 40A or less, silencer cannot be selected.

For other special options, refer to page 7.

G thread ^{Note 1)}
NPT thread ^{Note 1)}

Note 1) For options with silencer,
the exhaust port is Rc.

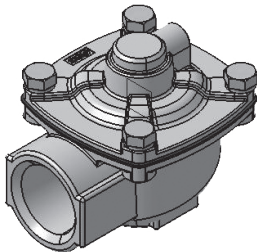

A: Direct piping type

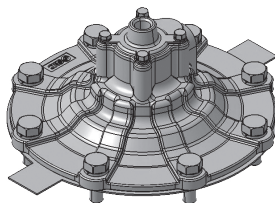

B: Flange type

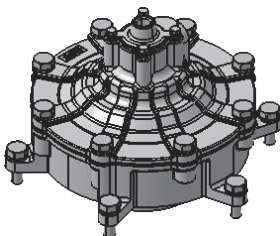

C: Flange body I type
(Flange mounting type)

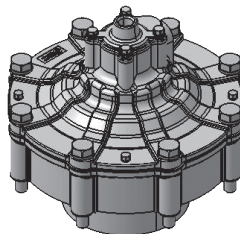

D: Flange body II type
(Through hole mounting type)

Caution
Selection of Pilot Valve

When selecting the air operated type VXFA2 series,
select the 2 port valve with the stated orifice diameter
or more.

VXFA21 to VXFA23: Ø 5 mm or more
VXFA24 to VXFA28: Ø 4 mm or more

Symbol

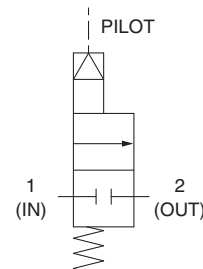

Refer to "Glossary of Terms" on
page 36 for symbol.

Series VXF2/VXFA2

Other Special Options

Electrical Option (Special voltage, with light)

VXF2 1 A A Z 1A

Enter standard product number.

Electrical option

Special voltage – Electrical entry/Electrical option

Specifications	Symbol	Voltage	Electrical entry
Special voltage	1A	48 VAC	Grommet ^{Note 2)} (with surge voltage suppressor)
	1B	220 VAC	
	1C	240 VAC	
	1U	24 VAC	
	1D	12 VDC	Grommet
	1E	12 VDC	Grommet (with surge voltage suppressor)
	1F	48 VAC	DIN terminal (with surge voltage suppressor)
	1G	220 VAC	
	1H	240 VAC	
	1V	24 VAC	
	1J	12 VDC	Conduit terminal (with surge voltage suppressor)
	1K	48 VAC	
	1L	220 VAC	
	1M	240 VAC	
	1W	24 VAC	Conduit ^{Note 2)} (with surge voltage suppressor)
	1N	12 VDC	
	1P	48 VAC	
	1Q	220 VAC	
	1R	240 VAC	Faston terminal
	1Y	24 VAC	
1S	12 VDC		
1T	12 VDC		
With light	2A	24 VDC	DIN terminal (with surge voltage suppressor)
	2B	100 VAC	
	2C	110 VAC	
	2D	200 VAC	
	2E	230 VAC	
	2F	48 VAC	
	2G	220 VAC	
	2H	240 VAC	Conduit terminal (with surge voltage suppressor)
	2V	24 VAC	
	2J	12 VDC	
	2K	24 VDC	
	2L	100 VAC	
	2M	110 VAC	
	2N	200 VAC	
2P	230 VAC	DIN terminal (with surge voltage suppressor)	
2Q	48 VAC		
2R	220 VAC		
2S	240 VAC		
2W	24 VAC		
2T	12 VDC		
2U	24 VDC		
Without DIN connector	3A	24 VDC	DIN terminal (with surge voltage suppressor)
	3B	100 VAC	
	3C	110 VAC	
	3D	200 VAC	
	3E	230 VAC	
	3F	48 VAC	
	3G	220 VAC	
3H	240 VAC		
3V	24 VAC		
3J	12 VDC		

Note 1) For high temperature type, DC specification, DIN terminal and Faston terminal are not available.

Note 2) For high temperature type, the surge voltage suppressor for grommet or conduit is attached in the middle of lead wire.

Other Option (Port thread)

VXF(A)2 1 A A A

Enter standard product number.

Piping option
Port thread

Symbol	Port thread
A	G
B	NPT

Air Operated Type

VXFA2 1 A A

Enter standard product number.

Piping option
Port thread

Symbol	Port thread
A	G ^{Note 2)}
B	NPT ^{Note 2)}

Note 2) For options with silencer, the exhaust port is Rc.

* Enter symbols in the order below when ordering an electrical option and other option.

Example) Solenoid valve type

VXF2 1 A A Z 1A A

Electrical option

Other option

VXF2/VXFA2 Series Valve Characteristics

The valve characteristics data was measured with the stated outlet piping length. The valve characteristics vary depending on the tank capacity, air supply, set pressure, outlet conditions (nozzle size, quantity, piping length), so please use these values as a guideline.

1. Response Time, Start-up Speed

VXF2 Type

Measuring conditions

Test circuit Refer to the circuit below.

Test sample···VXF21A (Port size 3/4) VXF22A (Port size 1)
VXF23A (Port size 1 1/2) VXF24A (Port size 2)
VXF25A, B (Port size 2 1/2) VXF26A, B, C, D (Port size 3)
VXF27B (Port size 3 1/2) VXF28B (Port size 4)

Air tank capacity···VXF21 to VXF22: 100 L
VXF23 to VXF24: 200 L
VXF25 to VXF28: 1000 L

Energising time·····150 msec

Rated voltage·····24 VDC

Outlet piping length·····500 mm

Thread size of outlet piping···VXF21: Rc3/8 VXF22: Rc1/2
VXF23: Rc3/4 VXF24: Rc1
VXF25: Rc1 1/2 VXF26: Rc2
VXF27: Rc2 1/2 VXF28: Rc3

How to calculate

1. Set the tank pressure to 0.5 MPa.
2. Close the stop valve on the inlet of the tank.
3. Energise the valve and read the pressure wave on the outlet.

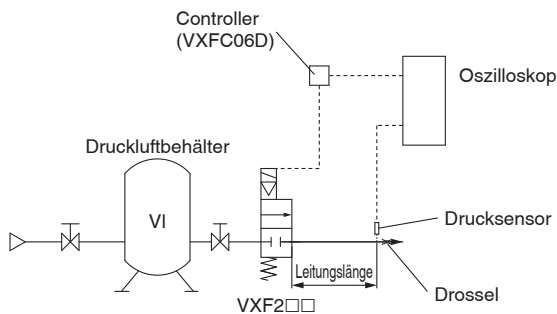

VXF2□ Test circuit

VXFA2 Type

Measuring conditions

Test circuit Refer to the circuit below.

Test sample···VXFA21A (Port size 3/4) VXFA22A (Port size 1)
VXFA23A (Port size 1 1/2) VXFA24A (Port size 2)
VXFA25A, B (Port size 2 1/2) VXFA26A, B, C, D (Port size 3)
VXFA27B (Port size 3 1/2) VXFA28B (Port size 4)

Air tank capacity···VXFA21 to VXFA22: 100 L
VXFA23 to VXFA24: 200 L
VXFA25 to VXFA28: 1000 L

Energising time·····150 msec

Pilot valve

VX232AA (Orifice, ø5, Rated voltage 24 VDC)

Piping length to the pilot valve

500 mm, 1000 mm, 1500 mm (Ø 10, t = 1.5)

Outlet piping length·····500 mm

Thread size of outlet piping···VXFA21: Rc3/8 VXFA22: Rc1/2
VXFA23: Rc3/4 VXFA24: Rc1
VXFA25: Rc1 1/2 VXFA26: Rc2
VXFA27: Rc2 1/2 VXFA28: Rc3

How to calculate

1. Set the tank pressure to 0.5 MPa.
2. Close the stop valve on the inlet of the tank.
3. Energise the pilot valve and read the pressure wave on the outlet.

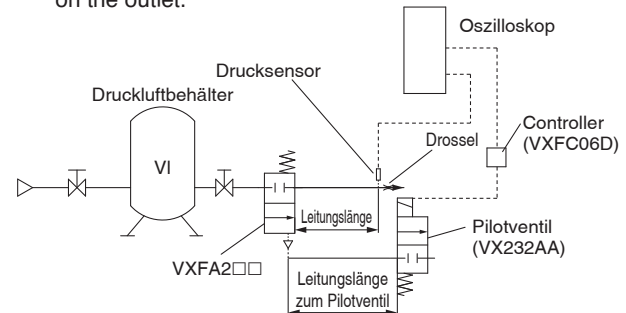

VXFA2□ Test circuit

ON response time

Time required until the valve is switched after it is energised
(Time required until pressure is released to the outlet)

Start-up speed

Speed until the valve is switched after being energised and the pressure released to the outlet reaches 90 % of the peak pressure

$$\text{Start-up speed} = (P_m \times 0.9) / \Delta t \quad [\text{MPa/msec}]$$

Note) For air operated type, the longer the piping length to the pilot valve, the longer the ON response time will be. If the piping length is increase even more, the valve may not open due to piping capacity and resistance in the piping, so keep the piping length to the pilot valve as short as possible.

How to Read the Data

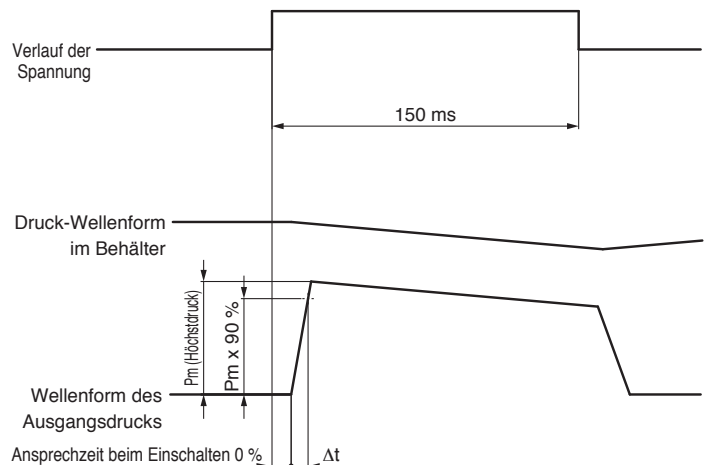

1. Response Time, Start-up Speed

For VXF2/solenoid valve type, the piping length to the pilot valve should be 0 mm.

ON Response Time

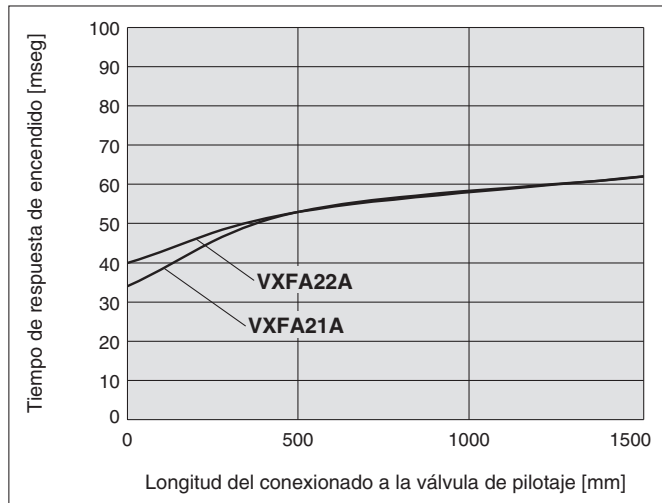

Start-up Speed

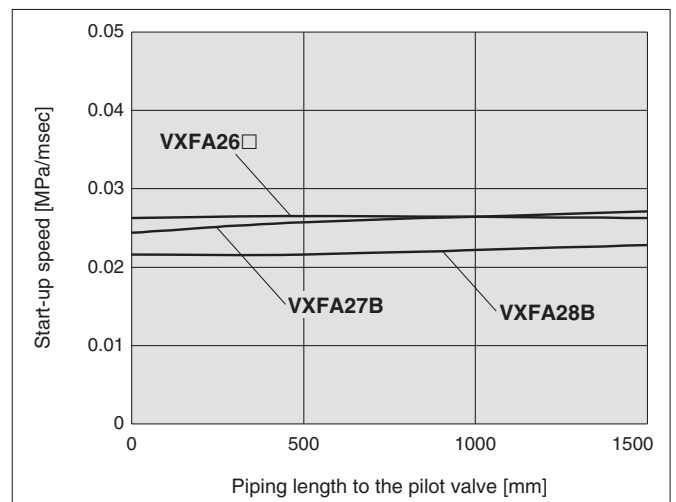
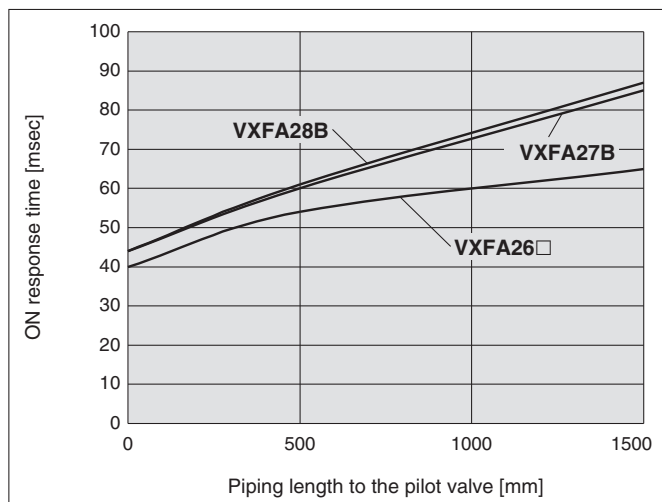
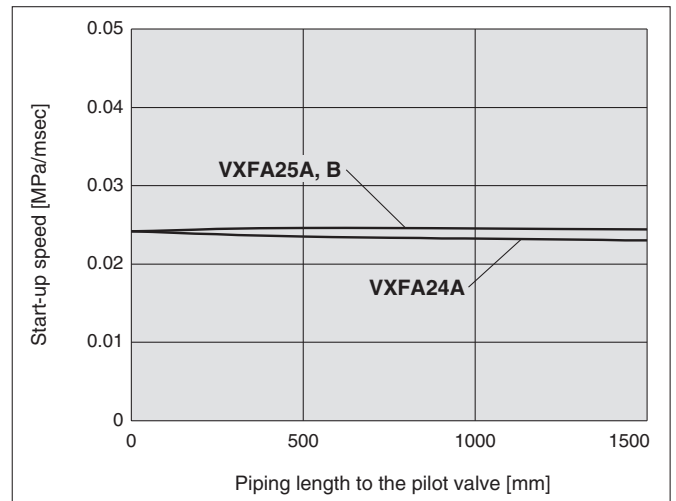
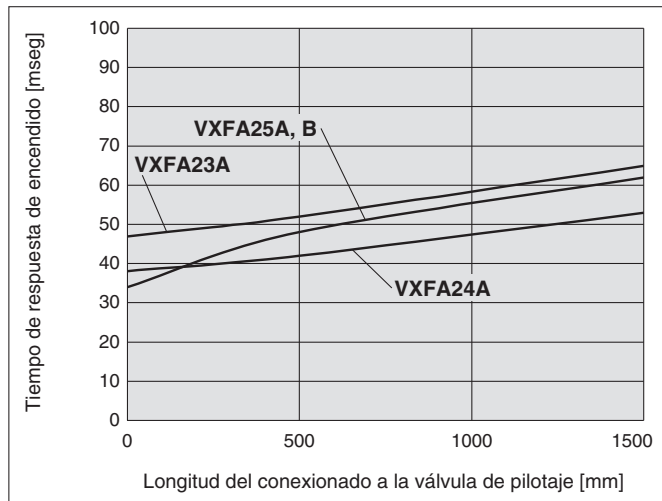
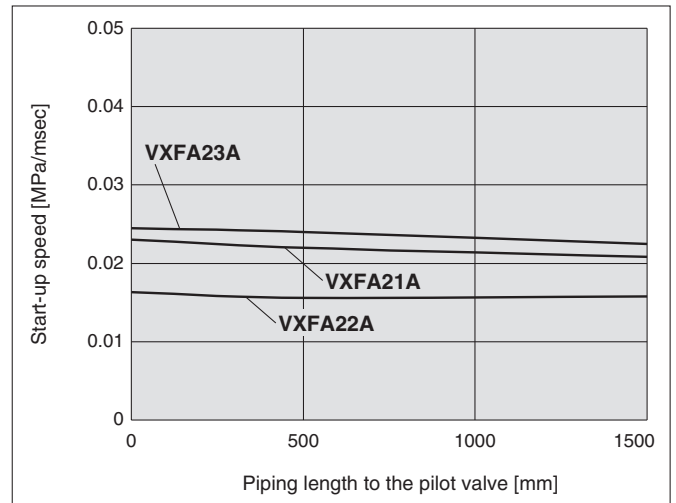

VXF2/VXFA2 Series

2. Discharge Volume

For VXF2/solenoid valve type, the piping length to the pilot valve should be 0 mm.

VXF2 Type

Measuring conditions

Test circuit Refer to the circuit below.

Test sample · VXF21A (Port size 3/4) VXF22A (Port size 1)
 VXF23A (Port size 1 1/2) VXF24A (Port size 2)
 VXF25A, B (Port size 2 1/2) VXF26A, B, C, D (Port size 3)
 VXF27B (Port size 3 1/2) VXF28B (Port size 4)

Air tank capacity · VXF21 to VXF22: 100 L
 VXF23 to VXF24: 200 L
 VXF25 to VXF28: 1000 L

Energising time 150 msec

Rated voltage 24 VDC

Outlet piping length 500 mm

Thread size of outlet piping Open

How to calculate

1. Set the tank pressure to 0.5 MPa.
2. Close the stop valve on the inlet of the tank.
3. Energise the valve and read the tank pressure after releasing the pressure.

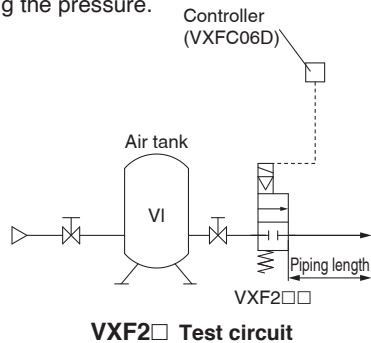

VXFA2 Type

Measuring conditions

Test circuit Refer to the circuit below.

Test sample · VXFA21A (Port size 3/4) VXFA22A (Port size 1)
 VXFA23A (Port size 1 1/2) VXFA24A (Port size 2)
 VXFA25A, B (Port size 2 1/2) VXFA26A, B, C, D (Port size 3)
 VXFA27B (Port size 3 1/2) VXFA28B (Port size 4)

Air tank capacity · VXFA21 to VXFA22: 100 L
 VXFA23 to VXFA24: 200 L
 VXFA25 to VXFA28: 1000 L

Energising time 150 msec

Pilot valve

VX232AA (Orifice, ø5, Rated voltage 24 VDC)

Piping length to the pilot valve

500 mm, 1000 mm, 1500 mm (Ø 10, t = 1.5)

Outlet piping length 500 mm

Thread size of outlet piping Open

How to calculate

1. Set the tank pressure to 0.5 MPa.
2. Close the stop valve on the inlet of the tank.
3. Energise the pilot valve and read the tank pressure after releasing the pressure.

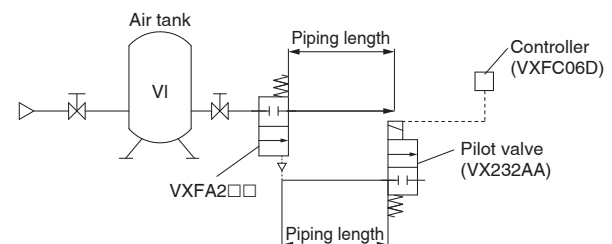

Discharge volume: Valve discharge volume per energising time

Conversion of the discharge volume

Calculate the discharge volume by reading the tank pressure after the valve starts the operation.

Conversion equation

$$V_0 = (P_1 \times V_1 - P_2 \times V_1) / P_0$$

V_0 : Discharge volume [L]

P_1 : Tank initial pressure [MPa] (Absolute pressure)

V_1 : Tank capacity [L]

P_2 : Tank pressure after release [MPa] (Absolute pressure)

P_0 : Atmospheric pressure [MPa] (Absolute pressure)

- Note 1) If the regulator or the restrictor is installed right before the IN side of the valve, the valve may oscillate when it is turned off. Keep the regulator or the restrictor away from the valve for at least 1 m or change restriction.
- Note 2) The dust collector valve is a large flow control valve in which air is discharged with high speed to clean the bag filter with impact wave. Tank capacity should be sufficient to secure impact wave and discharge flow rate. If the air tank capacity is insufficient, increased response time, malfunctions or oscillation may occur.

Discharge Volume

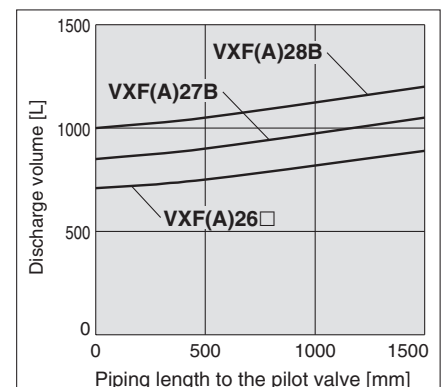
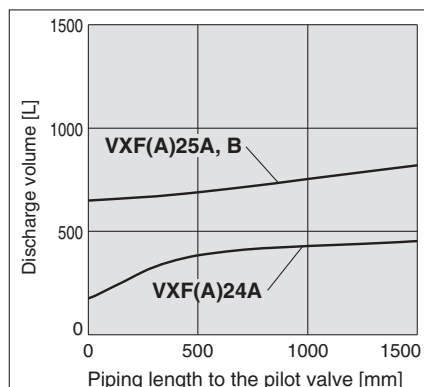
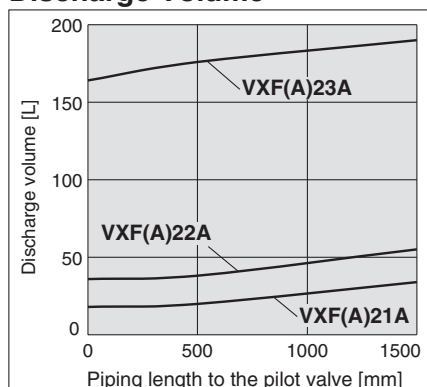

VXFA2 Series

Working Principle

VXFA21, 22, 23

De-energised

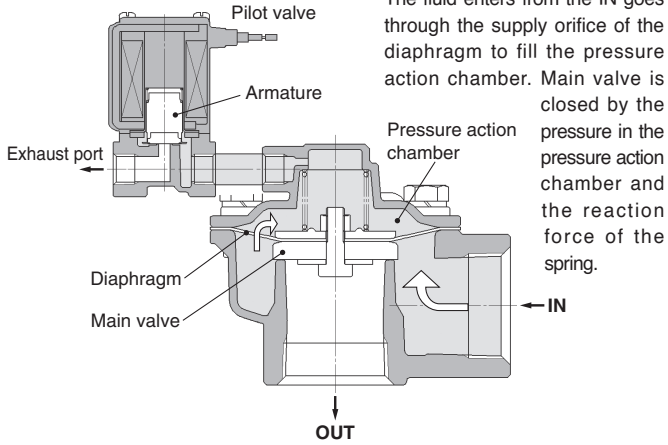

Right after energised

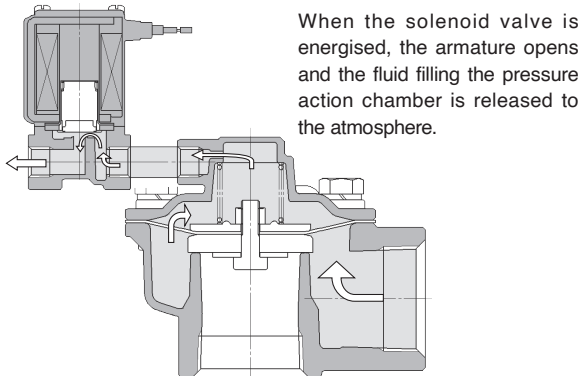

Energised (Main valve open)

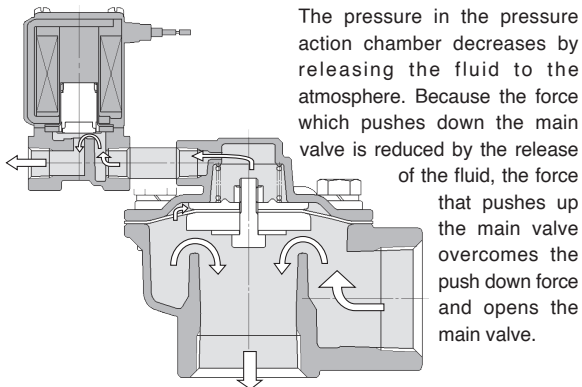

VXFA24 to 28 (Double diaphragm)

De-energised

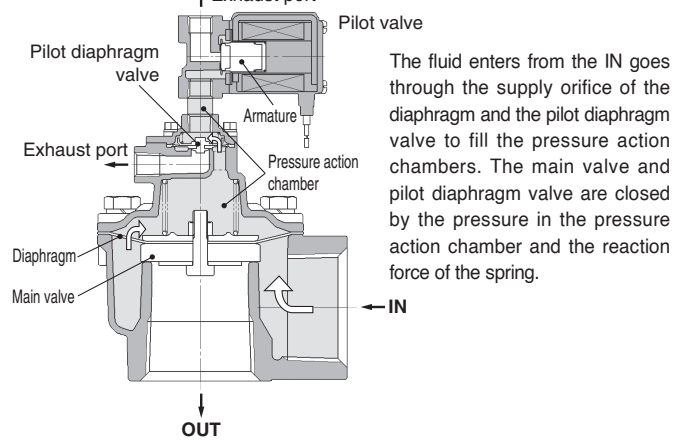

Right after energised

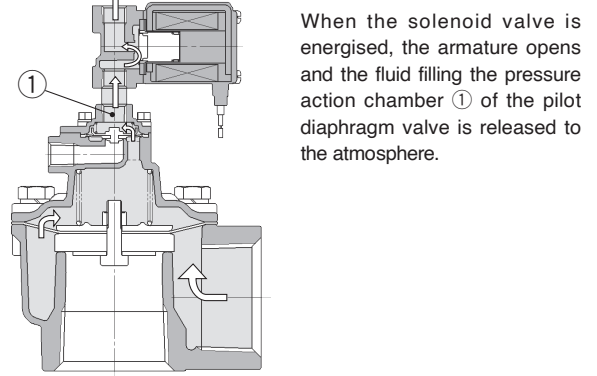

Energised (Pilot diaphragm valve open)

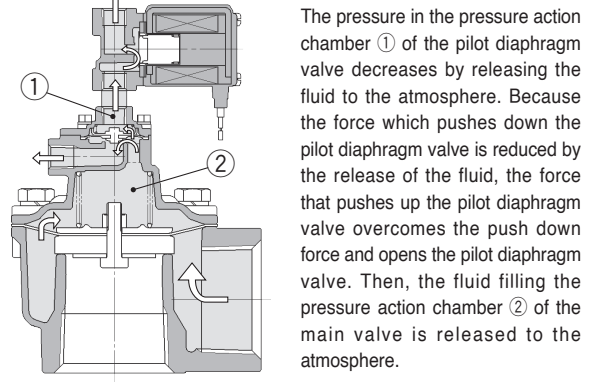

Energised (Main valve open)

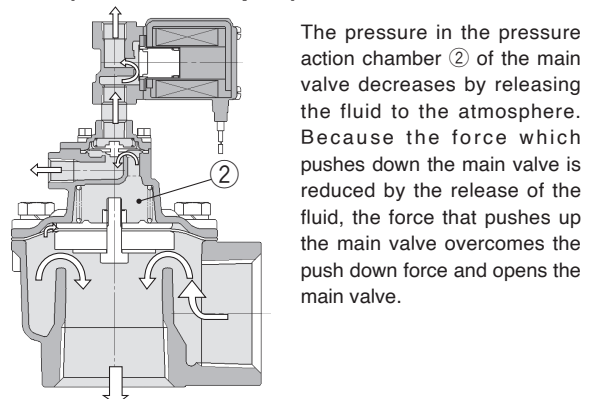

VXF2/VXFA2 Series

Construction

Solenoid Valve Type

VXF2 $\frac{1}{3}$ A□□/Direct piping type

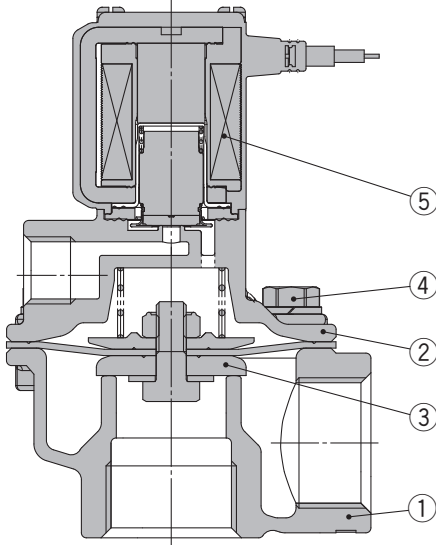

VXF2 $\frac{4}{6}$ A□□/Direct piping type

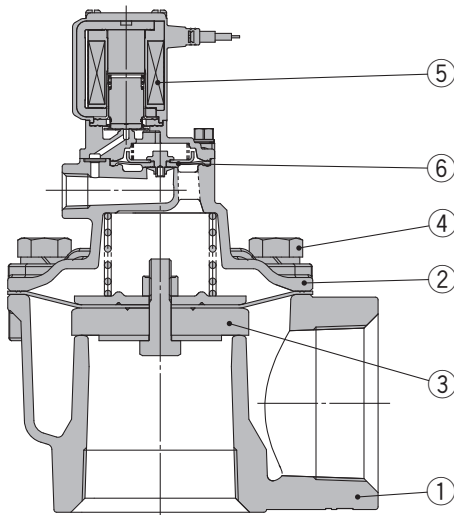

Air Operated Type

VXFA2 $\frac{1}{3}$ A□□/Direct piping type

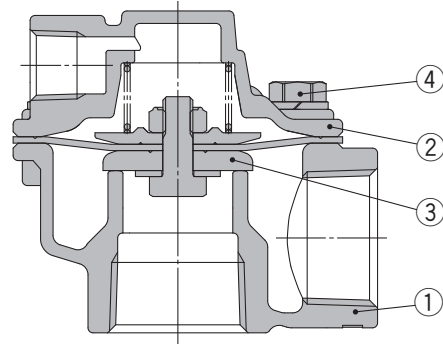

VXFA2 $\frac{4}{6}$ A□□/Direct piping type

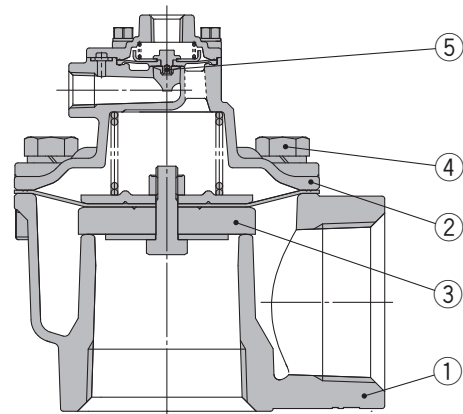

Component Parts

(): For high temperature

No.	Description	Material
1	Body	ADC
2	Bonnet	ADC
3	Diaphragm assembly	NBR (FKM), POM (PTFE), Stainless steel
4	Upset head bolt	FE
5	Pilot valve assembly	—
6	Diaphragm assembly for pilot valve	NBR (FKM), Stainless steel

Component Parts

(): For high temperature

No.	Description	Material
1	Body	ADC
2	Bonnet	ADC
3	Diaphragm assembly	NBR (FKM), POM (PTFE), Stainless steel
4	Upset head bolt	FE
5	Diaphragm assembly for pilot valve	NBR (FKM)

Replacement Parts (Direct piping type)

Model	Diaphragm assembly ^{Note 1)} (For normal temperature/high temperature)	Diaphragm assembly for pilot valve ^{Note 1)}		Silencer	
		Solenoid valve type (For normal temperature/high temperature)	Air operated type (For normal temperature/high temperature)	Solenoid valve type (For normal temperature/high temperature)	Air operated type (For normal temperature/high temperature)
VXF(A)21A(A,B,C,D)	VXF-21AA/VXF-21AC	—	—	AN20-02/EBKX-J2001-100	—
VXF(A)22A(A,B,C,D)	VXF-22AA/VXF-22AC	—	—	AN20-02/EBKX-J2001-100	—
VXF(A)23A(A,B,C,D)	VXF-23AA/VXF-23AC	—	—	AN20-02/EBKX-J2001-100	—
VXF(A)24A(A,B,C,D)	VXF-24AA/VXF-24AC	VXD30-3A-1A/VXD30-3A-F-1A	VXD30-3A-2A/VXD30-3A-F-2A	AN20-02/EBKX-J2001-100	AN20-02/EBKX-J2001-100
VXF(A)25A(A,B,C,D)	VXF-25AA/VXF-25AC	VXD40S-3A-1A/VXD40S-3A-F-1A	VXD40S-3A-2A/VXD40S-3A-F-2A	AN40-04/EBKX-J2003-120	AN40-04/EBKX-J2003-120
VXF(A)26A(A,C) ^{Note 2)}	VXF-26AA/VXF-26AC	VXD40S-3A-1A/VXD40S-3A-F-1A	VXD40S-3A-2A/VXD40S-3A-F-2A	—	—
VXF(A)26A(B,D) ^{Note 2)}	VXF-26AB/VXF-26AD	VXD40S-3A-1A/VXD40S-3A-F-1A	VXD40S-3A-2A/VXD40S-3A-F-2A	AN40-04/EBKX-J2003-120	AN40-04/EBKX-J2003-120

Note 1) Spring is shipped together with the product, but not assembled.

Note 2) When the VXF26 is ordered without a silencer, and a silencer is attached later by the user, the operation may become unstable while ON. When attaching a silencer later, be sure to replace the diaphragm assembly as well. When ordering a product with a silencer and is used without the silencer, the operation may become unstable while OFF. In this case, the diaphragm assembly should be replaced.

Construction

Solenoid Valve Type

VXF2⁵/₆⁷B□□/Flange type
8

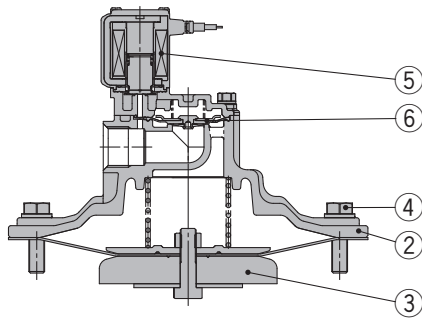

VXF26C□□/Flange body I type

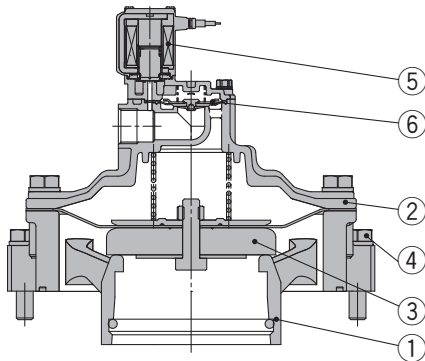

VXF26D□□/Flange body II type

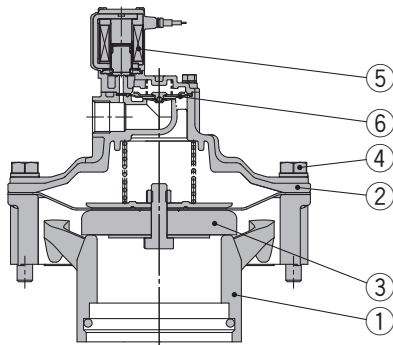

Component Parts

(): For high temperature

No.	Description	Material
1	Body	ADC
2	Bonnet	ADC
3	Diaphragm assembly	NBR (FKM), POM (PTFE), Stainless steel
4	Upset head bolt	FE
5	Pilot valve assembly	—
6	Diaphragm assembly for pilot valve	NBR (FKM), Stainless steel

Air Operated Type

VXFA2⁵/₆⁷B□□/Flange type
8

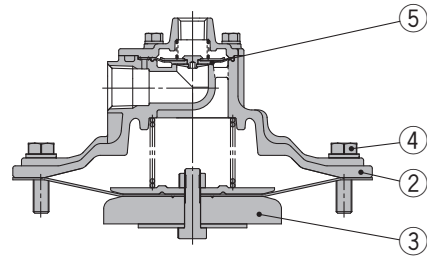

VXFA26C□□/Flange body I type

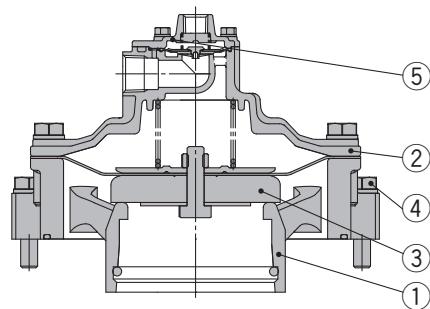

VXFA26D□□/Flange body II type

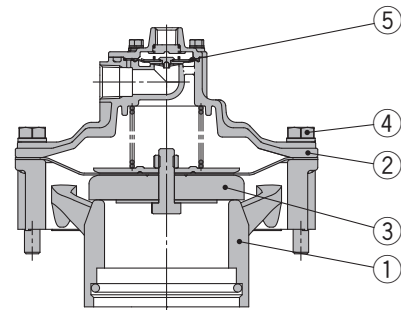

Component Parts

(): For high temperature

No.	Description	Material
1	Body	ADC
2	Bonnet	ADC
3	Diaphragm assembly	NBR (FKM), POM (PTFE), Stainless steel
4	Upset head bolt	FE
5	Diaphragm assembly for pilot valve	NBR (FKM), Stainless steel

Replacement Parts (Flange type, Flange body [I,II] type)

Model	Diaphragm assembly ^{Note 1)} (For normal temperature/high temperature)	Diaphragm assembly for pilot valve ^{Note 1)}		Silencer (For normal temperature/high temperature)
		Solenoid valve type (For normal temperature/high temperature)	Air operated type (For normal temperature/high temperature)	
VXF(A)25B(A,B,C,D)	VXF-25AA/VXF-25AC	VXD40S-3A-1A/VXD40S-3A-F-1A	VXD40S-3A-2A/VXD40S-3A-F-2A	AN40-04/EBKX-J2003-120
VXF(A)26B(A,C) ^{Note 2)}	VXF-26BA/VXF-26BC	VXD40S-3A-1A/VXD40S-3A-F-1A	VXD40S-3A-2A/VXD40S-3A-F-2A	—
VXF(A)26B(B,D) ^{Note 2)}	VXF-26BB/VXF-26BD	VXD40S-3A-1A/VXD40S-3A-F-1A	VXD40S-3A-2A/VXD40S-3A-F-2A	AN40-04/EBKX-J2003-120
VXF(A)26C(A,C) ^{Note 2)}	VXF-26CA/VXF-26CC	VXD40S-3A-1A/VXD40S-3A-F-1A	VXD40S-3A-2A/VXD40S-3A-F-2A	—
VXF(A)26C(B,D) ^{Note 2)}	VXF-26CB/VXF-26CD	VXD40S-3A-1A/VXD40S-3A-F-1A	VXD40S-3A-2A/VXD40S-3A-F-2A	AN40-04/EBKX-J2003-120
VXF(A)26D(A,C) ^{Note 2)}	VXF-26CA/VXF-26CC	VXD40S-3A-1A/VXD40S-3A-F-1A	VXD40S-3A-2A/VXD40S-3A-F-2A	—
VXF(A)26D(B,D) ^{Note 2)}	VXF-26CB/VXF-26CD	VXD40S-3A-1A/VXD40S-3A-F-1A	VXD40S-3A-2A/VXD40S-3A-F-2A	AN40-04/EBKX-J2003-120
VXF(A)27B(A,B,C,D)	VXF-27BA/VXF-27BC	VXD40S-3A-1A/VXD40S-3A-F-1A	VXD40S-3A-2A/VXD40S-3A-F-2A	AN40-04/EBKX-J2003-120
VXF(A)28B(A,B,C,D)	VXF-28BA/VXF-28BC	VXD40S-3A-1A/VXD40S-3A-F-1A	VXD40S-3A-2A/VXD40S-3A-F-2A	AN40-04/EBKX-J2003-120

Note 1) Spring is shipped together with the product, but not assembled.

Note 2) When the VXF26 is ordered without a silencer, and a silencer is attached later by the user, the operation may become unstable while ON. When attaching a silencer later, be sure to replace the diaphragm assembly as well. When ordering a product with a silencer and is used without the silencer, the operation may become unstable while OFF. In this case, the diaphragm assembly should be replaced.

VXF2 Series

Dimensions: **Direct piping type** VXF21A□□□/22A□□□/23A□□□

Grommet

Grommet (with surge voltage suppressor)

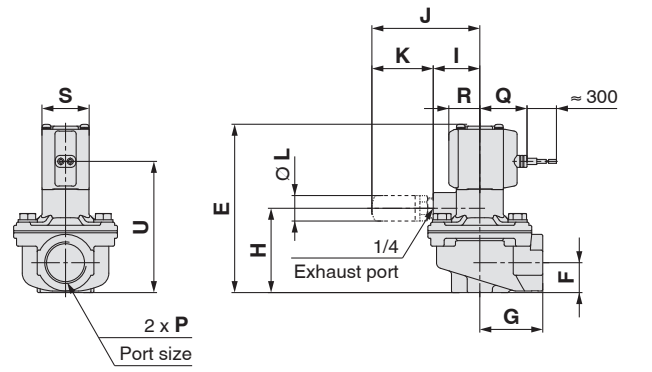
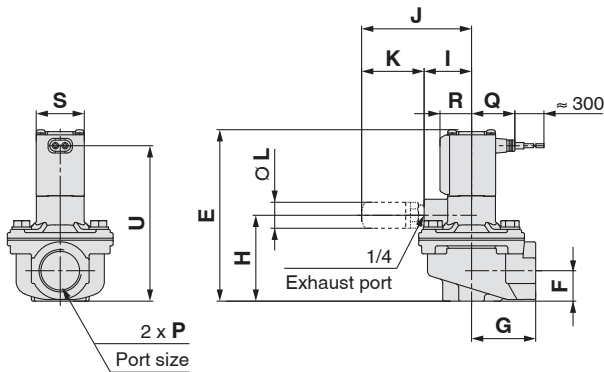

DIN terminal

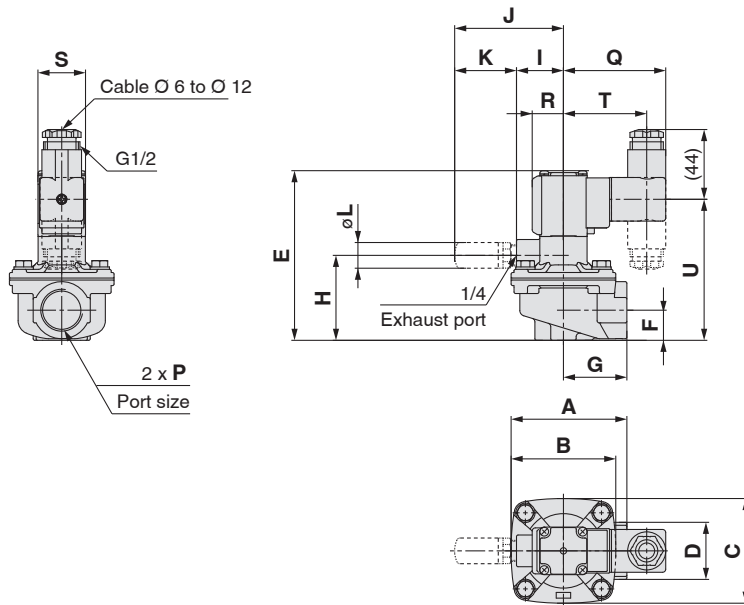

Dimensions

[mm]

Model	Port size P	A	B	C	D	E	F	G	H	I	J	K	L	S
VXF21A□	3/4	73	66	66	36	107	19	40	53.5	29.5	68.5 (70.8)	39 (41.3)	16.5 (17)	30
VXF22A□	1	84	74	74	45	118	23.5	47	64.5	29.5	68.5 (70.8)	39 (41.3)	16.5 (17)	30
VXF23A□	1 1/2	132	110	110	63	154.5	35	77	95	32	71 (73.3)	39 (41.3)	16.5 (17)	35

Model	Grommet			Grommet (with surge voltage suppressor)			DIN terminal			
	Q	R	U	Q	R	U	Q	R	U	T
VXF21A□	27	20	97	30	20	83.5	64.5	20	89	52.5
VXF22A□	27	20	108	30	20	94.5	64.5	20	100	52.5
VXF23A□	29.5	22	143.5	32.5	22	130	67	22	135.5	55

* (): When the symbol "D" for high temperature is selected.

Dimensions: **Direct piping type** VXF21A□□□/22A□□□/23A□□□

Conduit terminal

Conduit

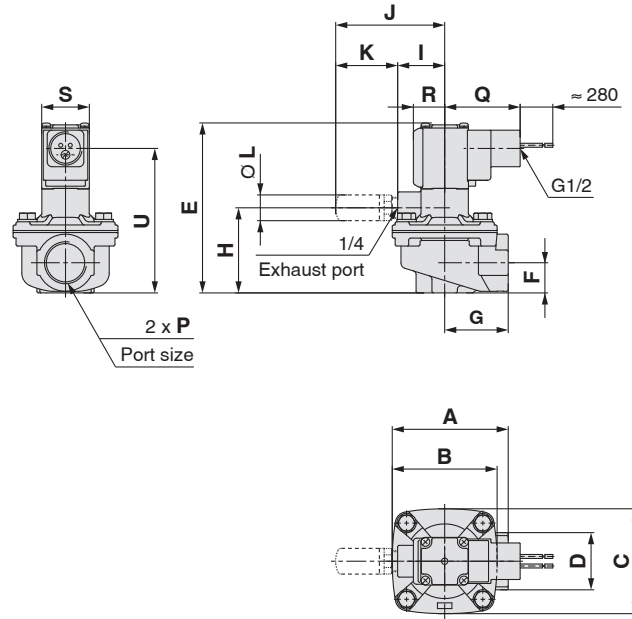
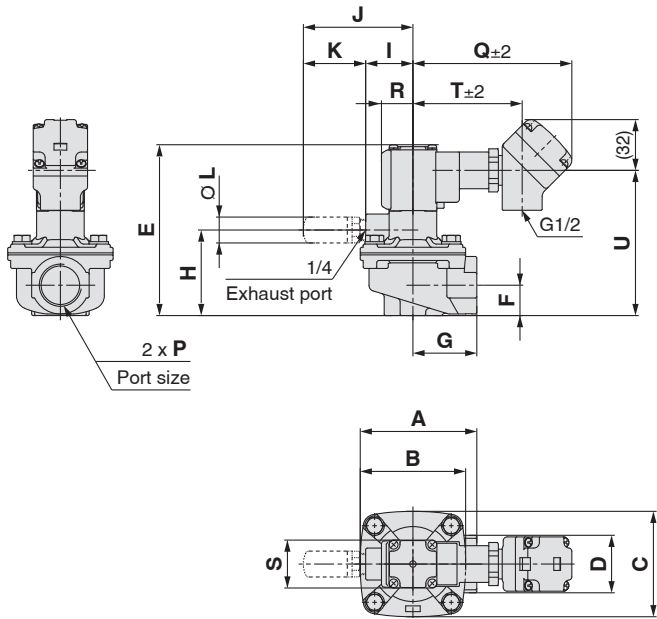

Flat terminal

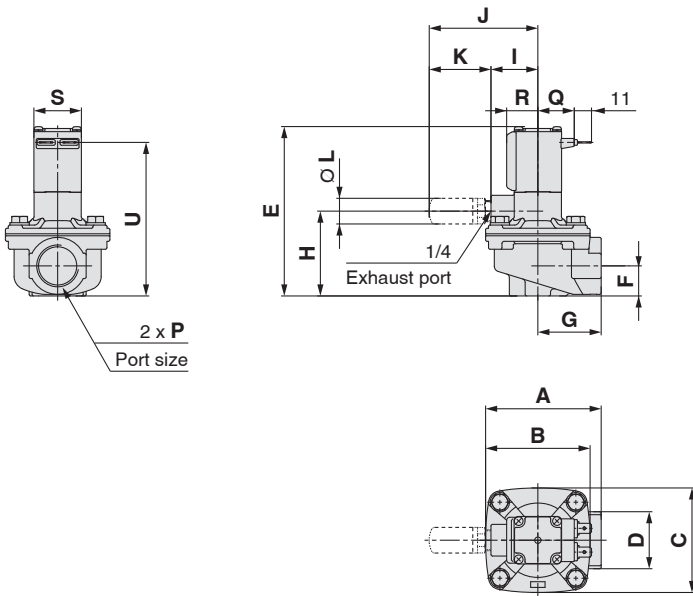

Dimensions

[mm]

Model	Port size P	A	B	C	D	E	F	G	H	I	J	K	L	S
VXF21A□	3/4	73	66	66	36	107	19	40	53.5	29.5	68.5 (70.8)	39 (41.3)	16.5 (17)	30
VXF22A□	1	84	74	74	45	118	23.5	47	64.5	29.5	68.5 (70.8)	39 (41.3)	16.5 (17)	30
VXF23A□	1 1/2	132	110	110	63	154.5	35	77	95	32	71 (73.3)	39 (41.3)	16.5 (17)	35

Model	Conduit terminal				Conduit			Flat terminal		
	Q	R	U	T	Q	R	U	Q	R	U
VXF21A□	99.5	20	91	68.5	47.5	20	91	23	20	97
VXF22A□	99.5	20	102	68.5	47.5	20	102	23	20	108
VXF23A□	102	22	137.5	71	50	22	137.5	25.5	22	143.5

* () : When the symbol "D" for high temperature is selected.

VXF2 Series

Dimensions: **Direct piping type** VXF24A□□□

Grommet

Grommet (with surge voltage suppressor)

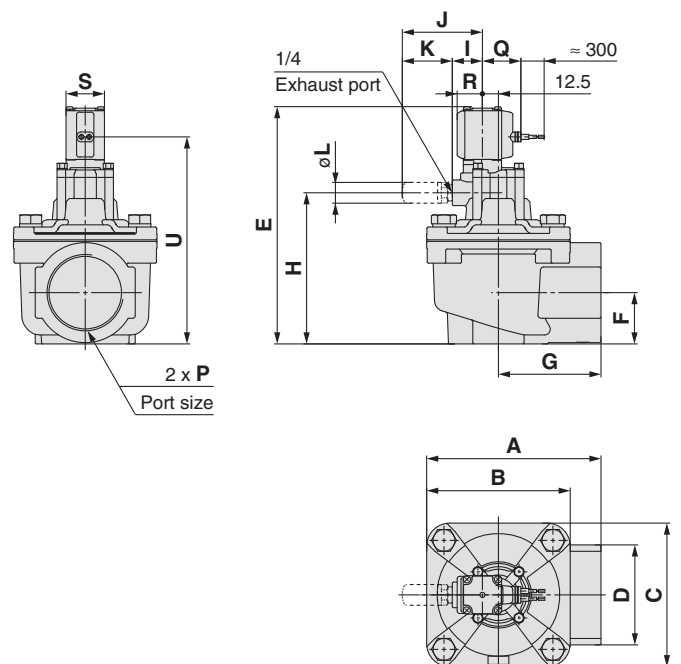
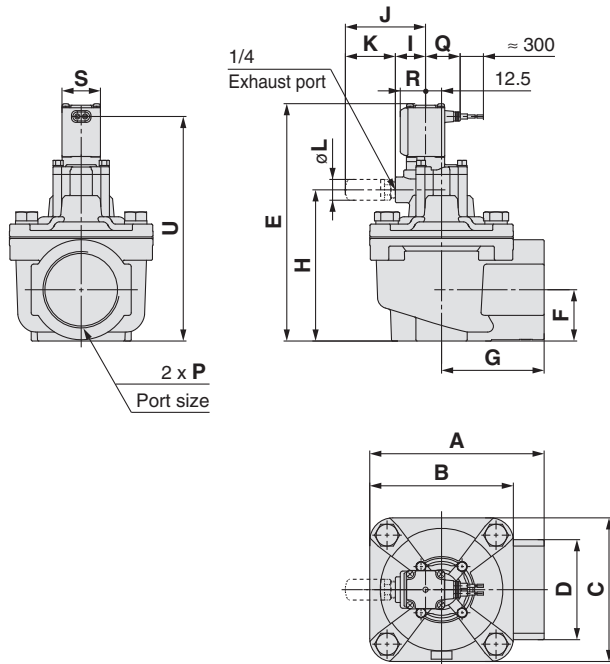

DIN terminal

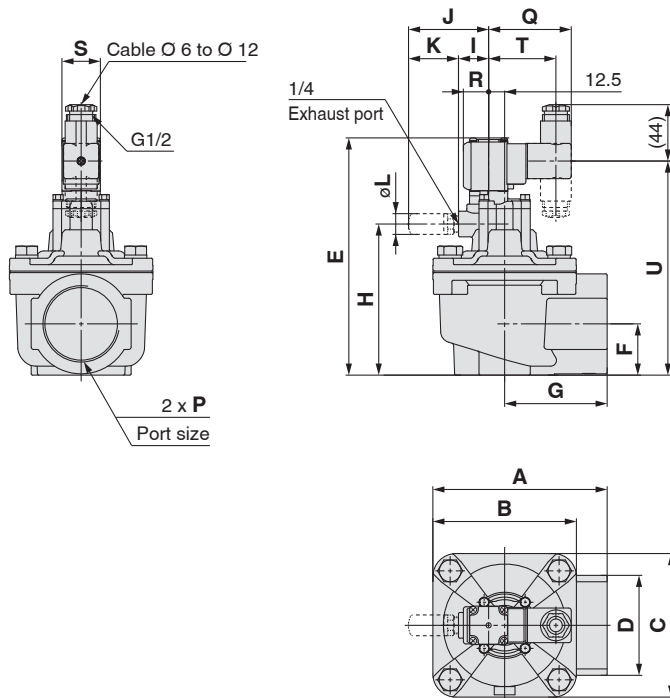

Dimensions

[mm]

Model	Port size P	A	B	C	D	E	F	G	H	I	J	K	L	S
VXF24A□	2	136	112	112	78	185	40	80	118	23.5	62.5 (64.8)	39 (41.3)	16.5 (17)	30
Model	Grommet			Grommet (with surge voltage suppressor)			DIN terminal							
	Q	R	U	Q	R	U	Q	R	U	T				
VXF24A□	27	20	175	30	20	161.5	64.5	20	167	52.5				

* () : When the symbol "D" for high temperature is selected.

Dimensions: **Direct piping type** VXF24A□□□

Conduit terminal

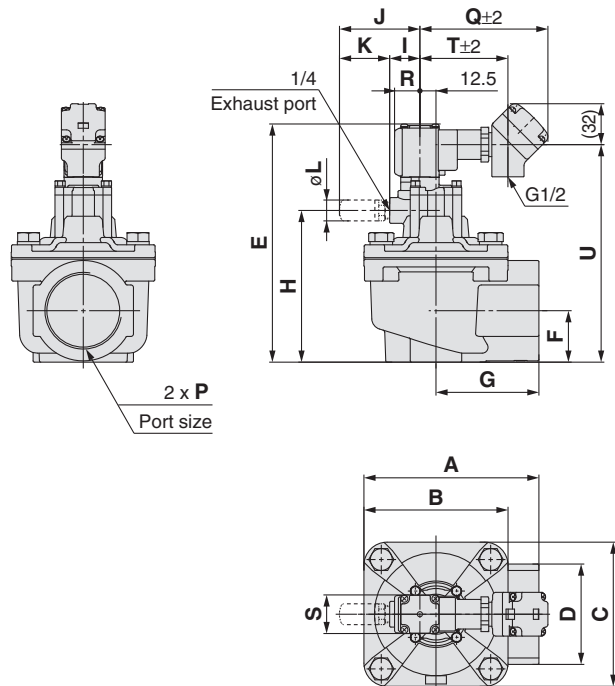

Conduit

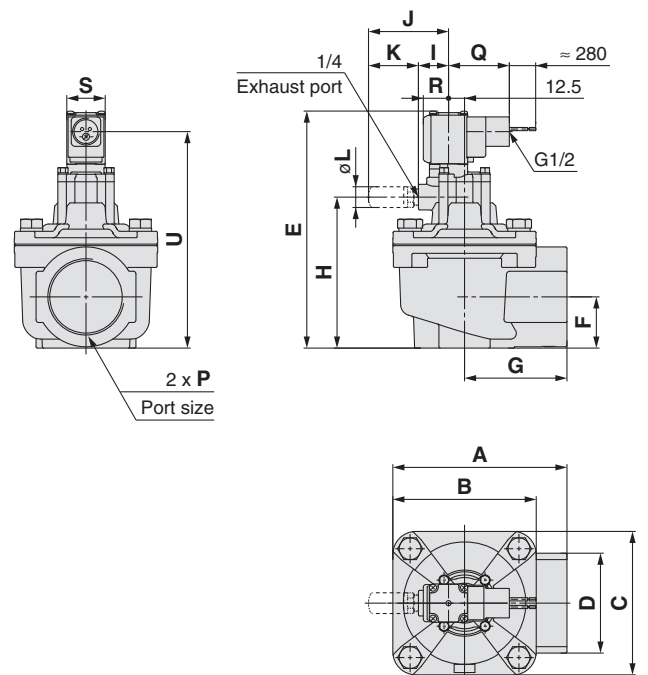

Flat terminal

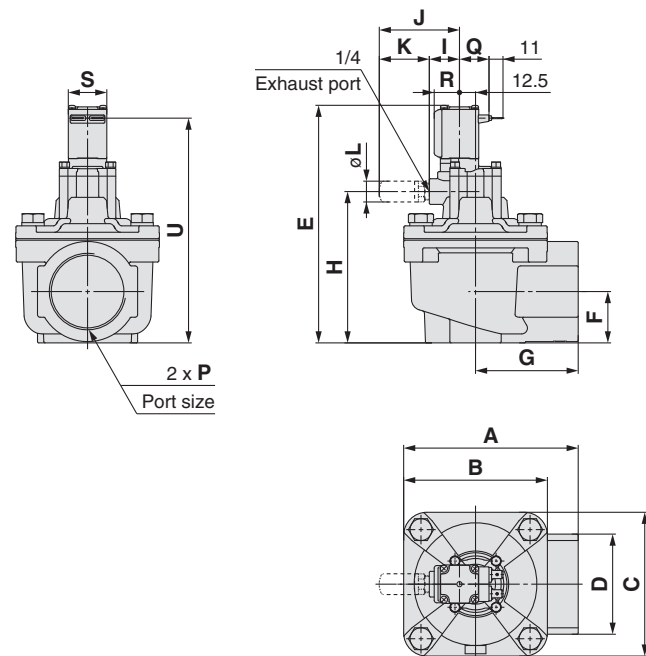

Dimensions

Model	Port size P	A	B	C	D	E	F	G	H	I	J	K	L	S
VXF24A□	2	136	112	112	78	185	40	80	118	23.5	62.5 (64.8)	39 (41.3)	16.5 (17)	30
Model	Conduit terminal				Conduit			Flat terminal						
	Q	R	U	T	Q	R	U	Q	R	U				
VXF24A□	99.5	20	169	68.5	47.5	20	169	23	20	175				

* (): When the symbol "D" for high temperature is selected.

VXF2 Series

Dimensions: **Direct piping type** VXF25A□□□/26A□□□

Grommet

Grommet (with surge voltage suppressor)

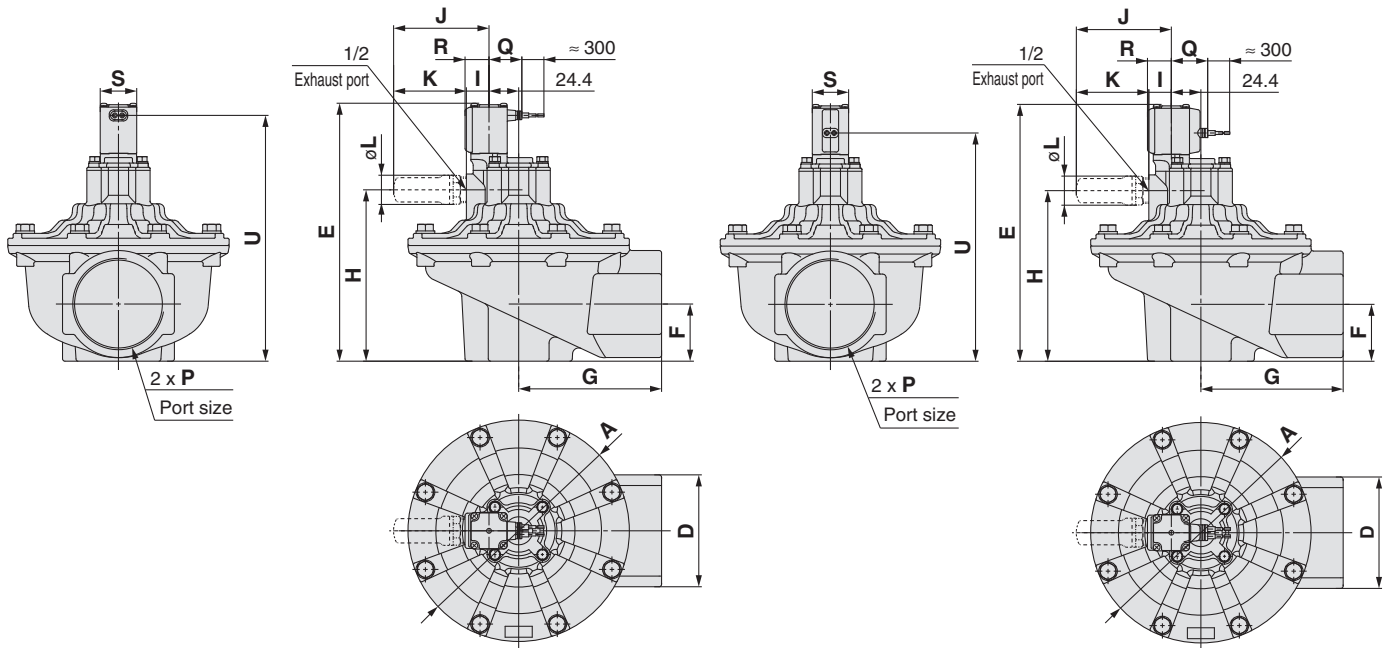

DIN terminal

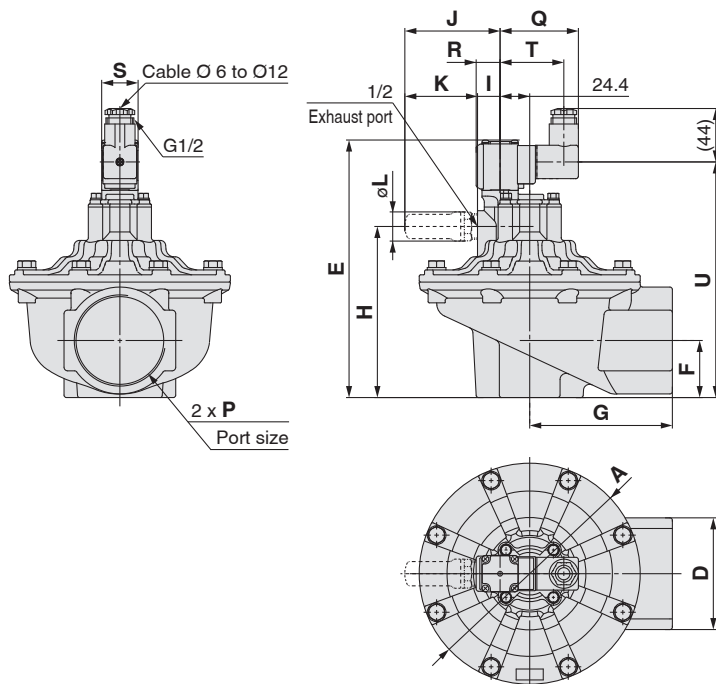

Dimensions

[mm]

Model	Port size P	A	D	E	F	G	H	I	J	K	L	S
VXF25A□	2 1/2	182	92	212	47	117.5	141	18.6	78.4 (70.2)	59.8 (43.1)	24 (17)	30
VXF26A□	3	206	102	247	63	119	176	18.6	78.4 (70.2)	59.8 (43.1)	24 (17)	30
Model	Grommet			Grommet (with surge voltage suppressor)			DIN terminal					
	Q	R	U	Q	R	U	Q	R	U	T		
VXF25A□	27	20	202	30	20	188.5	64.5	20	194	52.5		
VXF26A□	27	20	237	30	20	223.5	64.5	20	229	52.5		

* (): When the symbol "D" for high temperature is selected.

Dimensions: **Direct piping type** VXF25A□□□/26A□□□

Conduit terminal

Conduit

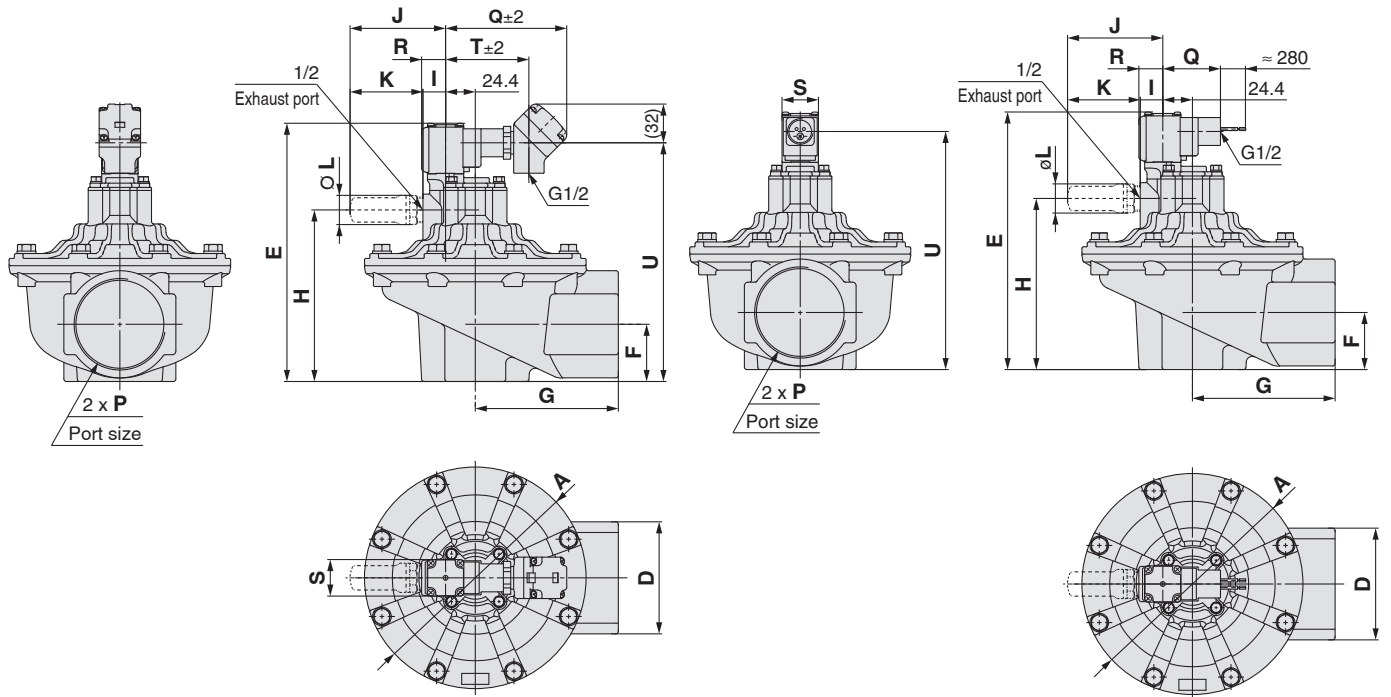

Flat terminal

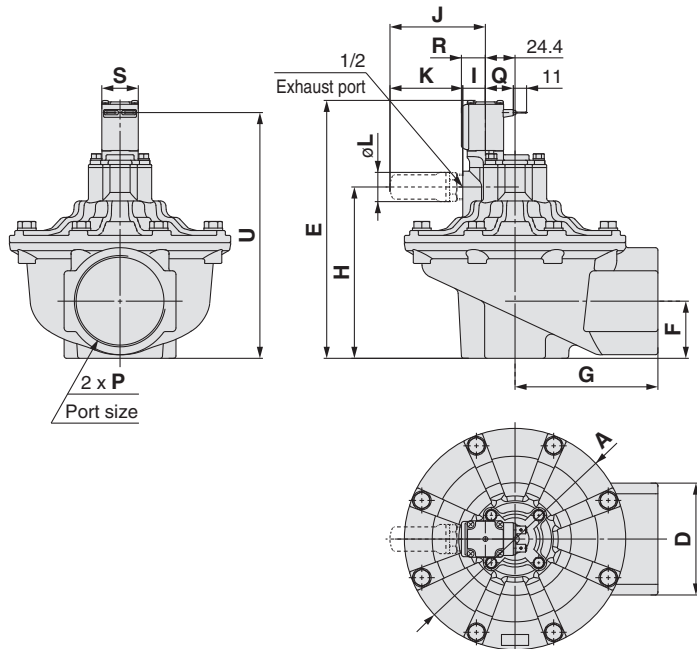

Dimensions

[mm]

Model	Port size P	A	D	E	F	G	H	I	J	K	L	S
VXF25A□	2 1/2	182	92	212	47	117.5	141	18.6	78.4 (70.2)	59.8 (43.1)	24 (17)	30
VXF26A□	3	206	102	247	63	119	176	18.6	78.4 (70.2)	59.8 (43.1)	24 (17)	30
Model	Conduit terminal				Conduit			Flat terminal				
	Q	R	U	T	Q	R	U	Q	R	U		
VXF25A□	99.5	20	196	68.5	47.5	20	196	23	20	202		
VXF26A□	99.5	20	231	68.5	47.5	20	231	23	20	237		

* (): When the symbol "D" for high temperature is selected.

VXF2 Series

Dimensions: **Flange type** VXF25B□□□/26B□□□/27B□□□/28B□□□

Grommet

Grommet (with surge voltage suppressor)

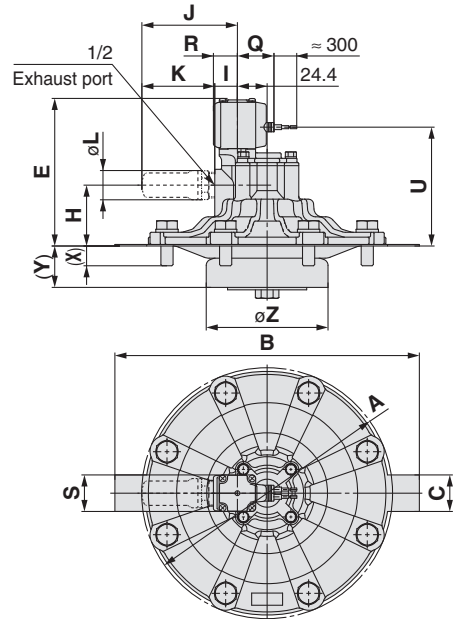
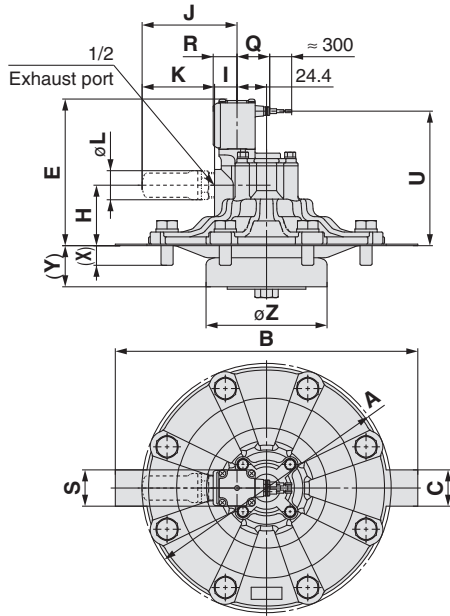

DIN terminal

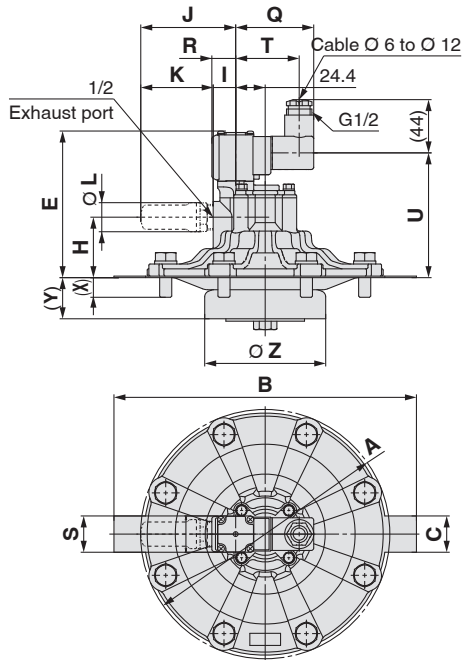

Note) Refer to page 23 for the dimensions on the mounting side.

Dimensions

[mm]

Model	A	B	C	E	H	I	X	Y	Z	J	K	L	S
VXF25B□	182	—	—	118	47	18.6	17	18.3	90	78.4 (70.2)	59.8 (43.1)	24 (17)	30
VXF26B□	206	250	30	121	50	18.6	17	34	100	78.4 (70.2)	59.8 (43.1)	24 (17)	30
VXF27B□	206	250	30	121	50	18.6	17	34	110	78.4 (70.2)	59.8 (43.1)	24 (17)	30
VXF28B□	206	250	30	121	50	18.6	17	34	120	78.4 (70.2)	59.8 (43.1)	24 (17)	30

Model	Grommet			Grommet (with surge voltage suppressor)			DIN terminal			
	Q	R	U	Q	R	U	Q	R	U	T
VXF25B□	27	20	108	30	20	94.5	64.5	20	100	52.5
VXF26B□	27	20	111	30	20	97.5	64.5	20	103	52.5
VXF27B□	27	20	111	30	20	97.5	64.5	20	103	52.5
VXF28B□	27	20	111	30	20	97.5	64.5	20	103	52.5

* (): When the symbol "D" for high temperature is selected.

Dimensions: **Flange type** VXF25B□□□/26B□□□/27B□□□/28B□□□

Conduit terminal

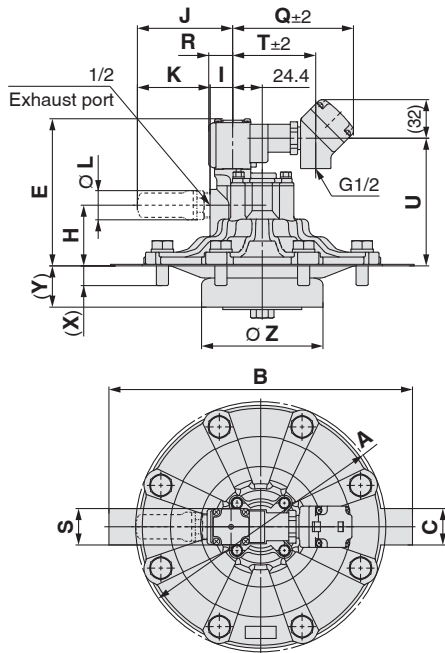

Conduit

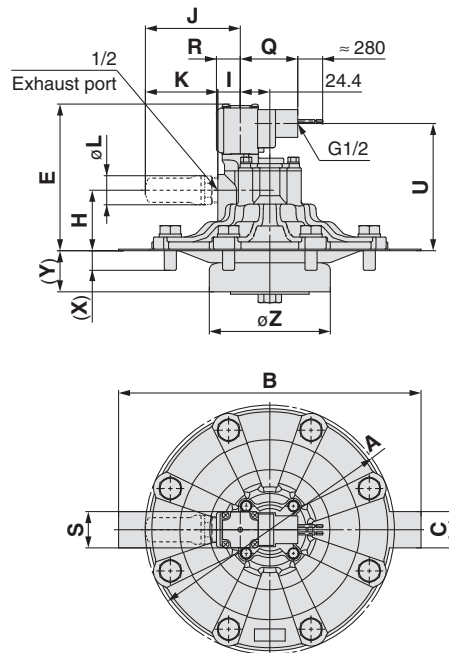

Flat terminal

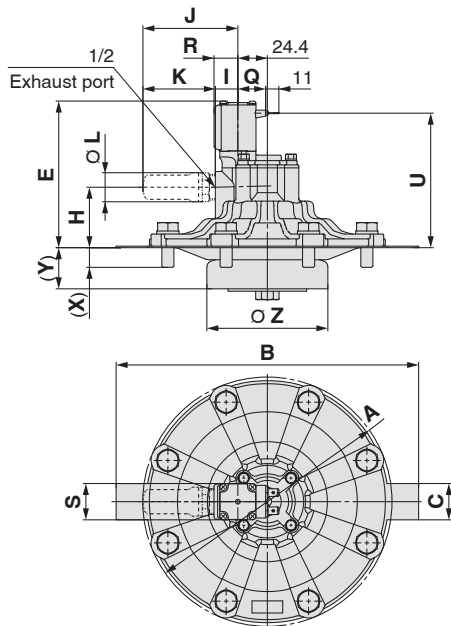

Note) Refer to page 23 for the dimensions of the mounting interface.

Dimensions

[mm]

Model	A	B	C	E	H	I	X	Y	Z	J	K	L	S
VXF25B□	182	—	—	118	47	18.6	17	18.3	90	78.4 (70.2)	59.8 (43.1)	24 (17)	30
VXF26B□	206	250	30	121	50	18.6	17	34	100	78.4 (70.2)	59.8 (43.1)	24 (17)	30
VXF27B□	206	250	30	121	50	18.6	17	34	110	78.4 (70.2)	59.8 (43.1)	24 (17)	30
VXF28B□	206	250	30	121	50	18.6	17	34	120	78.4 (70.2)	59.8 (43.1)	24 (17)	30

Model	Conduit terminal				Conduit			Flat terminal		
	Q	R	U	T	Q	R	U	Q	R	U
VXF25B□	99.5	20	102	68.5	47.5	20	102	23	20	108
VXF26B□	99.5	20	105	68.5	47.5	20	105	23	20	111
VXF27B□	99.5	20	105	68.5	47.5	20	105	23	20	111
VXF28B□	99.5	20	105	68.5	47.5	20	105	23	20	111

* (): When the symbol "D" for high temperature is selected.

VXF2 Series

Dimensions of the Mounting interface: **Flange type**

VXF25B□□□

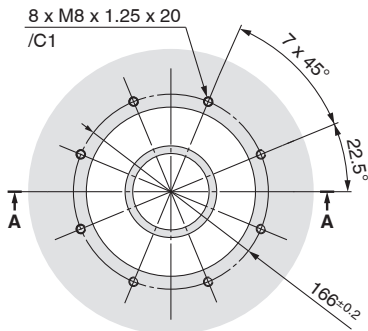

A-A

The surface roughness of the orifice should be Rz6.3 or less.

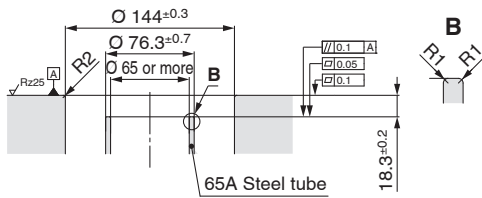

VXF26B□□□

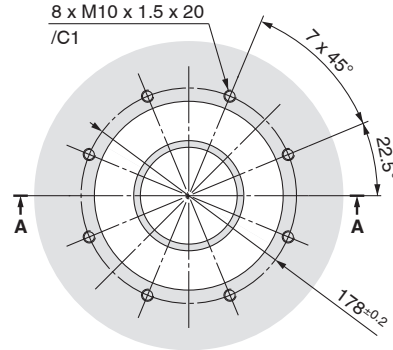

A-A

The surface roughness of the orifice should be Rz6.3 or less.

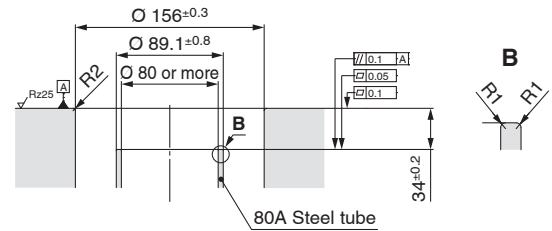

VXF27B□□□

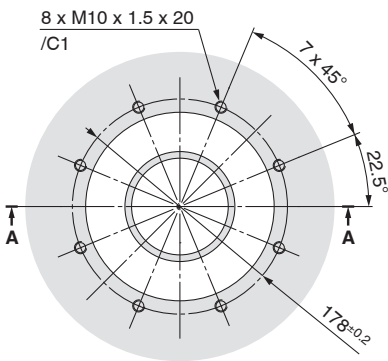

A-A

The surface roughness of the orifice should be Rz6.3 or less.

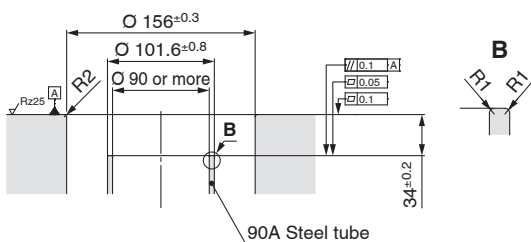

VXF28B□□□

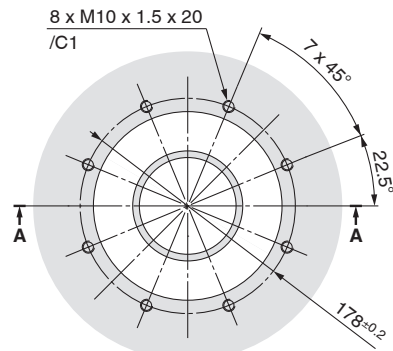

A-A

The surface roughness of the orifice should be Rz6.3 or less.

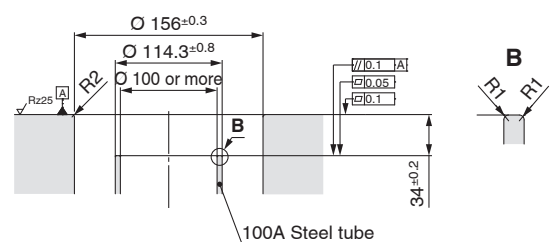

Dimensions: **Flange body I type** VXF26C□□□

Grommet

Grommet (with surge voltage suppressor)

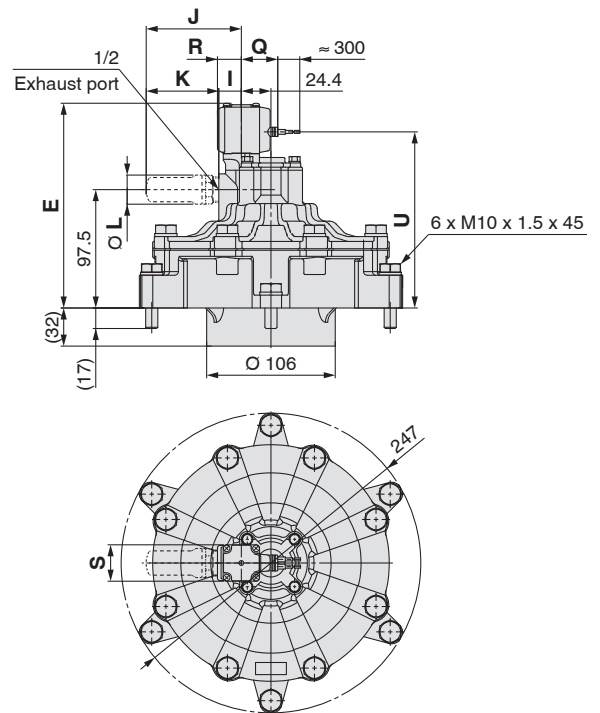
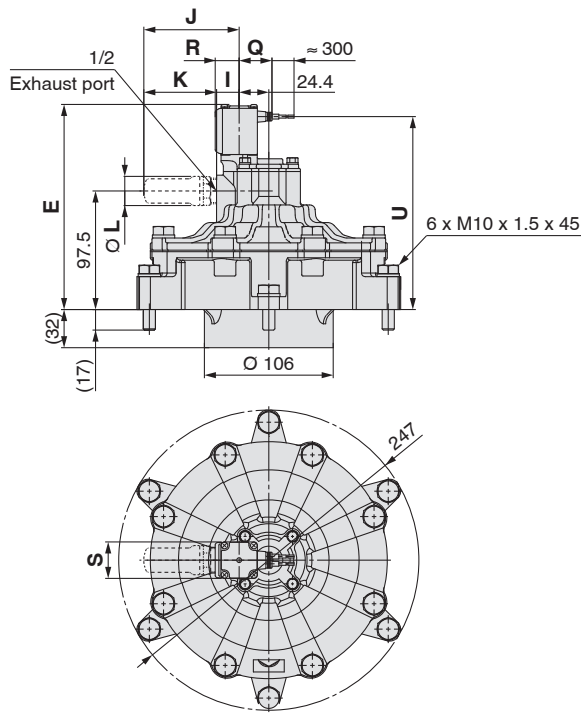

DIN terminal

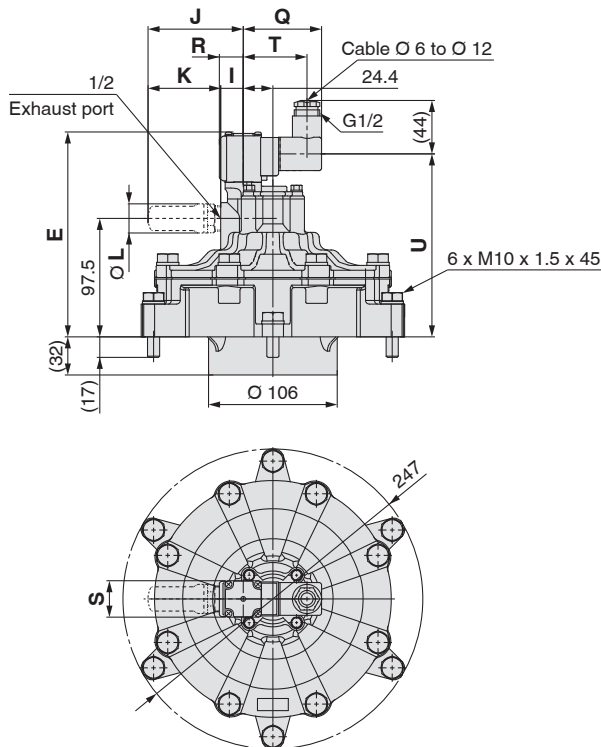

Note) Refer to page 26 for the dimensions of the mounting interface.

Dimensions

[mm]

Model	E	I	J	K	L	S	Grommet			Grommet (with surge voltage suppressor)			DIN terminal			
							Q	R	U	Q	R	U	Q	R	U	T
VXF26C□	169	18.6	78.4 (70.2)	59.8 (43.1)	24 (17)	30	27	20	159	30	20	145	64.5	20	151	52.5

* (): When the symbol "D" for high temperature is selected.

VXF2 Series

Dimensions: **Flange body I type** VXF26C□□□

Conduit terminal

Conduit

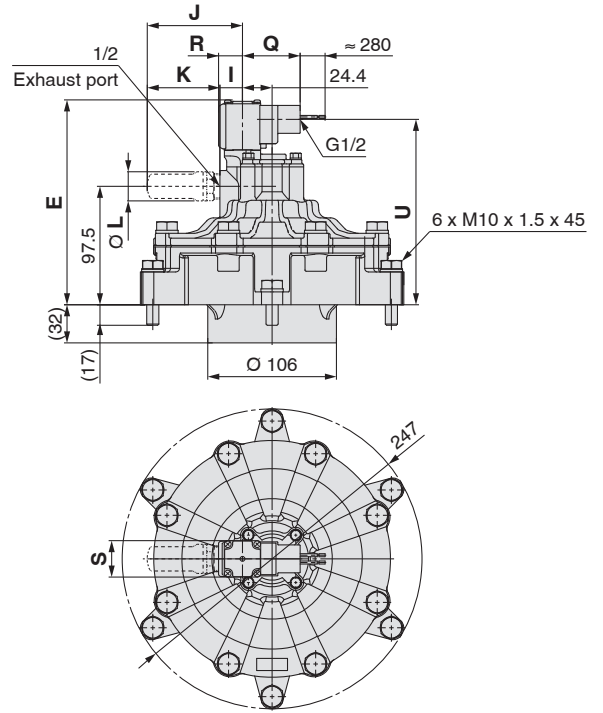
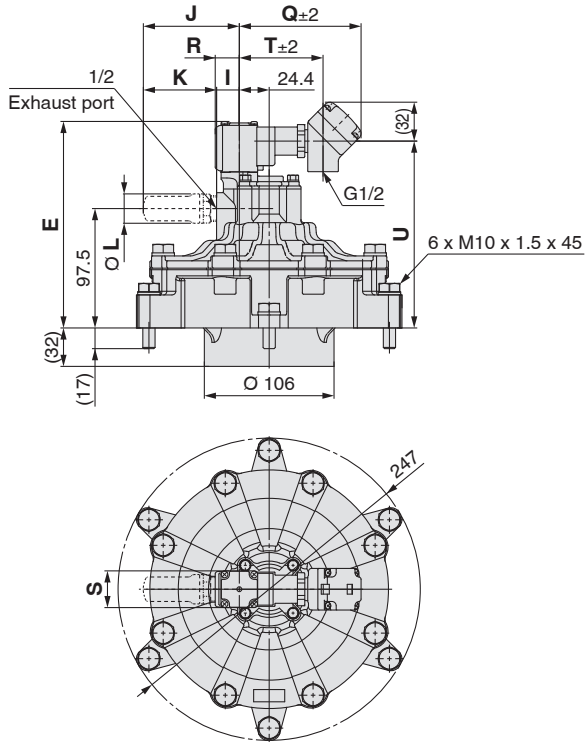

Flat terminal

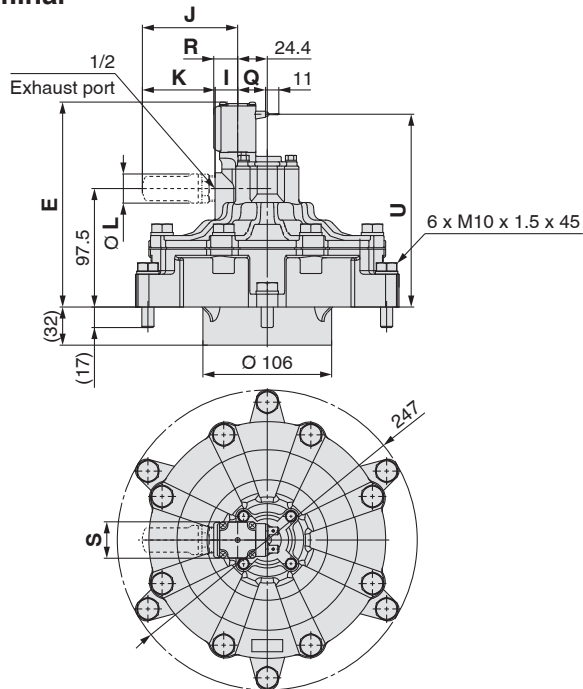

Note) Refer to page 28 for the dimensions of the mounting interface.

Dimensions

[mm]

Model	E	I	J	K	L	S	Conduit terminal				Conduit			Flat terminal		
							Q	R	U	T	Q	R	U	Q	R	U
VXF26C□	169	18.6	78.4 (70.2)	59.8 (43.1)	24 (17)	30	99.5	20	153	68.5	47.5	20	153	23	20	159

* (): When the symbol "D" for high temperature is selected.

Dimensions: **Flange body II type** VXF26D□□□

Grommet

Grommet (with surge voltage suppressor)

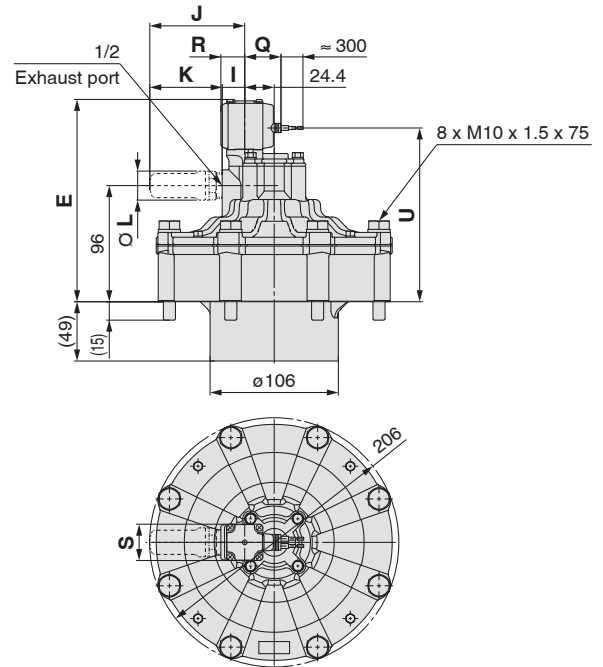
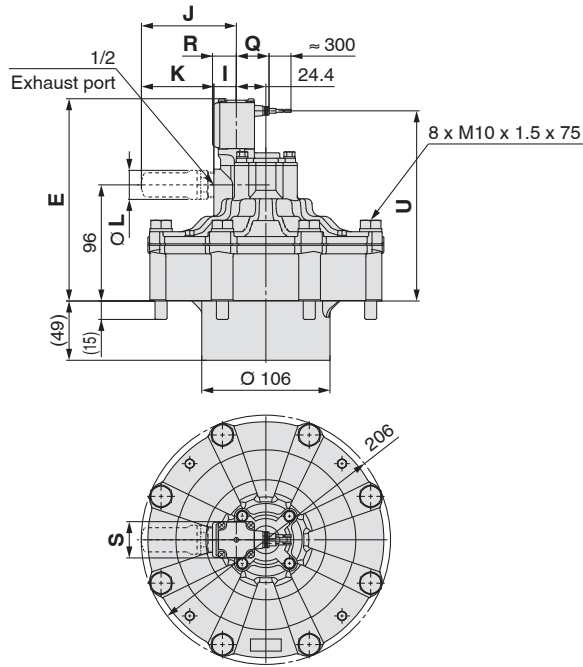

DIN terminal

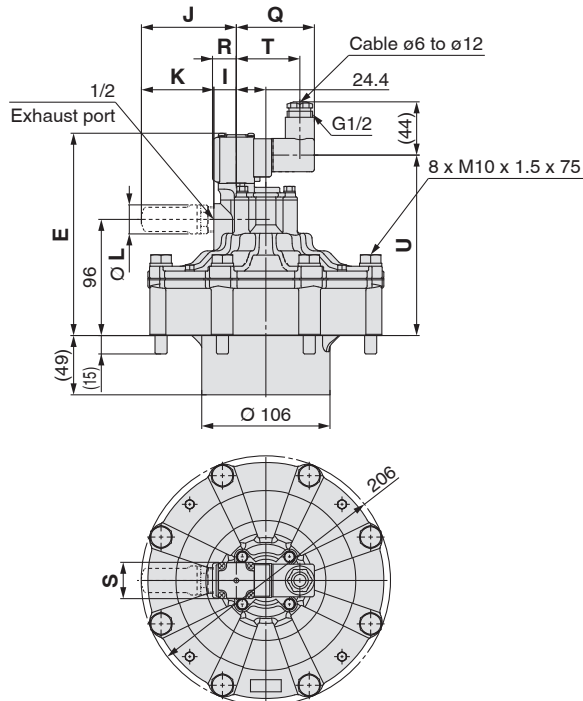

Note) Refer to page 28 for the dimensions of the mounting interface.

Dimensions

[mm]

Model	E	I	J	K	L	S	Grommet			Grommet (with surge voltage suppressor)			DIN terminal			
							Q	R	U	Q	R	U	Q	R	U	T
VXF26D□	167	18.6	78.4 (70.2)	59.8 (43.1)	24 (17)	30	27	20	157	30	20	143.5	64.5	20	149	52.5

* (): When the symbol "D" for high temperature is selected.

VXF2 Series

Dimensions: **Flange body II type** VXF26D□□□

Conduit terminal

Conduit

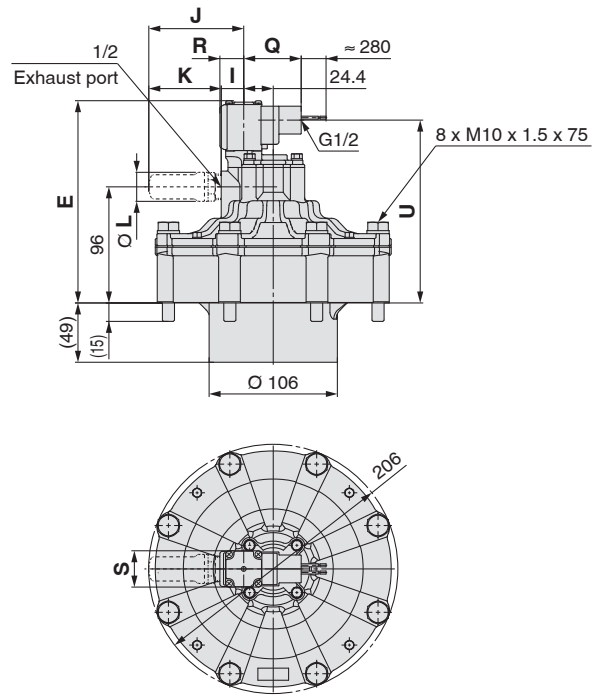
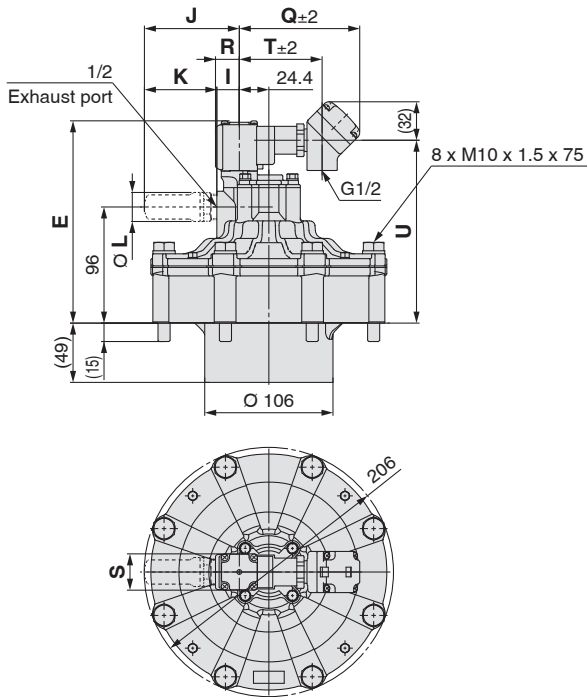

Flat terminal

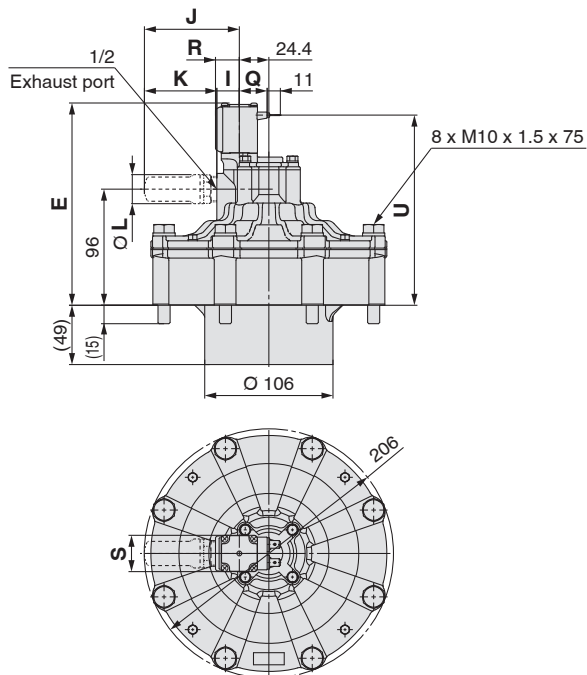

Note) Refer to page 28 for the dimensions of the mounting interface.

Dimensions

[mm]

Model	E	I	J	K	L	S	Conduit terminal				Conduit			Flat terminal		
							Q	R	U	T	Q	R	U	Q	R	U
VXF26D□	167	18.6	78.4 (70.2)	59.8 (43.1)	24 (17)	30	99.5	20	151	68.5	47.5	20	151	23	20	157

* (): When the symbol "D" for high temperature is selected.

Dimensions of the Mounting interface: Flange body I/II type

VXF26C□□□□

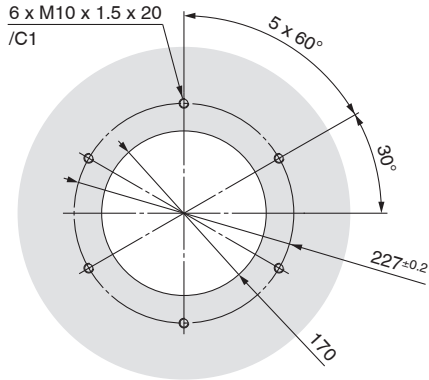

VXF26D□□□□

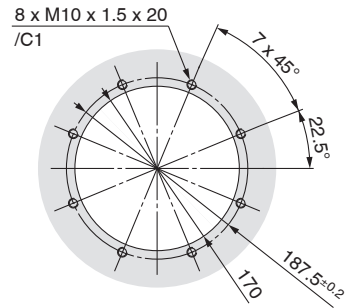

VXF26C□□□□ Piping

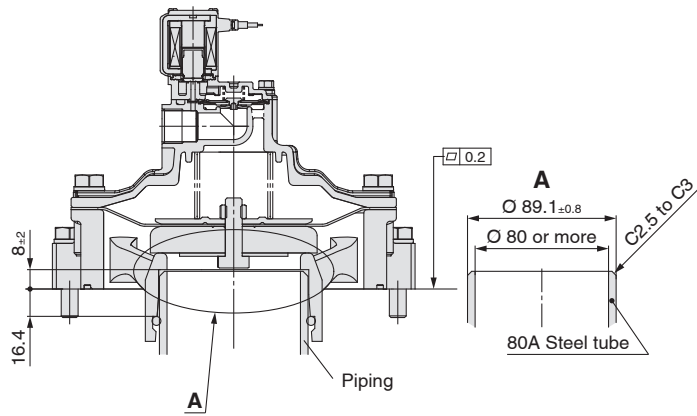

VXF26D□□□□ Piping

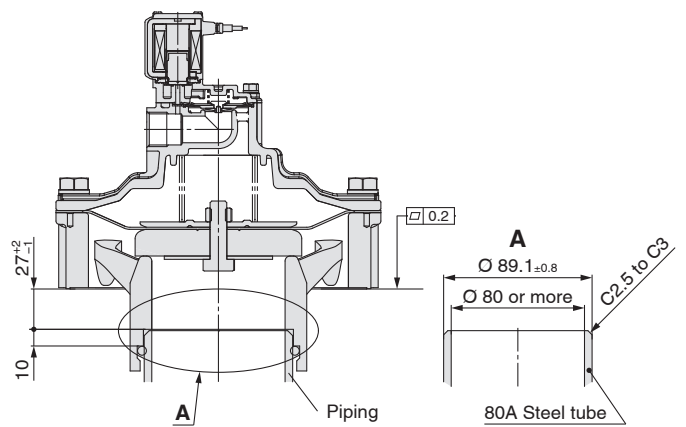

* Machine the mounting surface shape so that there are no gaps between the mounting surface and the product. Refer to page 38 for details.

VXFA2 Series

Dimensions: Direct piping type

VXFA21A□□□

VXFA22A□□□

VXFA23A□□□

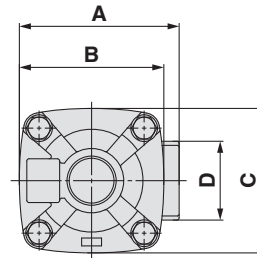
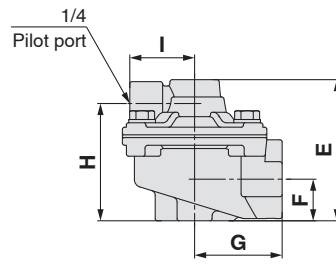
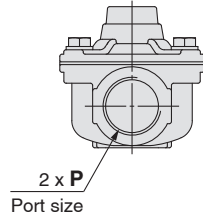

Dimensions

[mm]

Model	Port size P	A	B	C	D	E	F	G	H	I
VXFA21A□	3/4	73	66	66	36	64.5	19	40	53.5	29.5
VXFA22A□	1	84	74	74	45	74.5	23.5	47	64.5	29.5
VXFA23A□	1 1/2	132	110	110	63	106	35	77	95	32

VXFA24A□□□

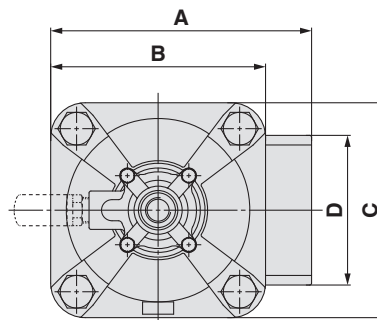
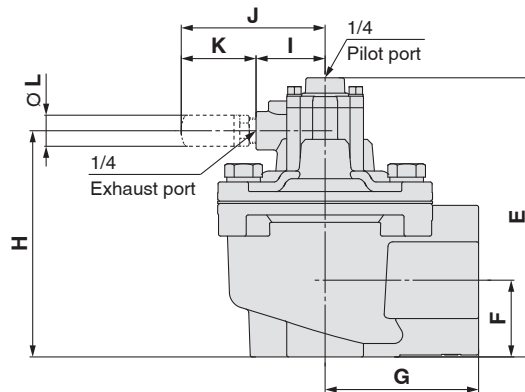
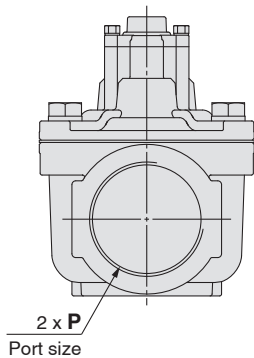

Dimensions

[mm]

Model	Port size P	A	B	C	D	E	F	G	H	I	J	K	L
VXFA24A□	2	136	112	112	78	145.5	40	80	118	36	75 (77.8)	39 (41.3)	16.5 (17)

* (): When the symbol "D" for high temperature is selected.

Dimensions: **Direct piping type**

VXFA25A□□□

VXFA26A□□□

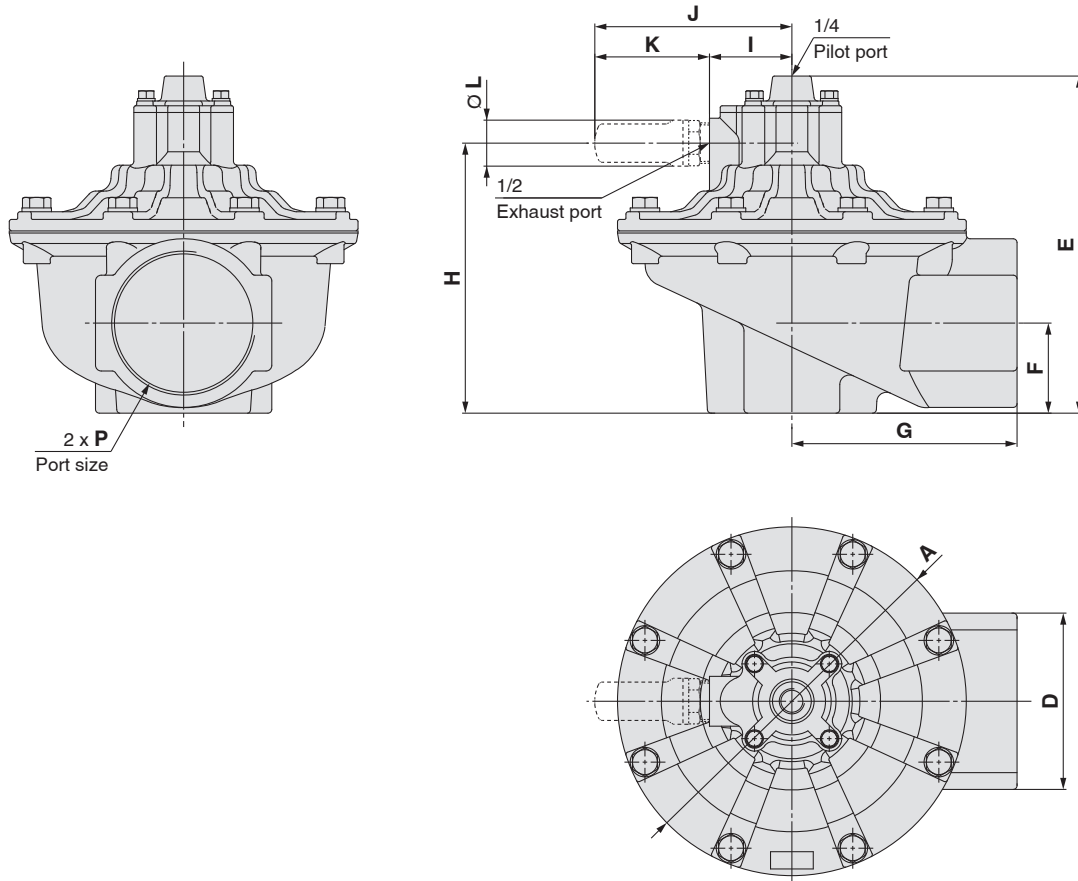

Dimensions

[mm]

Model	Port size P	A	D	E	F	G	H	I	J	K	L
VXFA25A□	2 1/2	182	92	176	47	117.5	141	43	102.8 (94.6)	59.8 (43.1)	24 (17)
VXFA26A□	3	206	102	211	63	119	176	43	102.8 (94.6)	59.8 (43.1)	24 (17)

* (): When the symbol "D" for high temperature is selected.

VXFA2 Series

Dimensions: **Flange type**

VXFA25B□□□

VXFA26B□□□

VXFA27B□□□

VXFA28B□□□

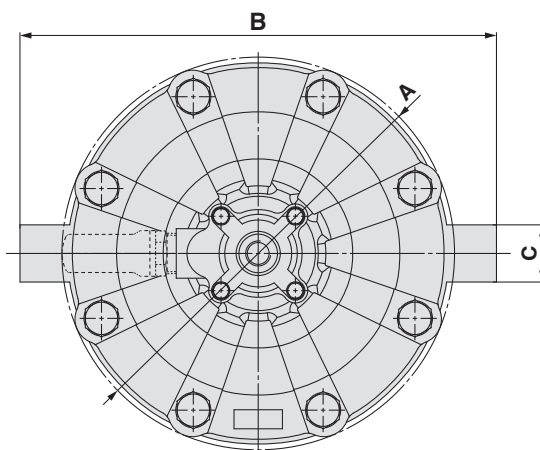
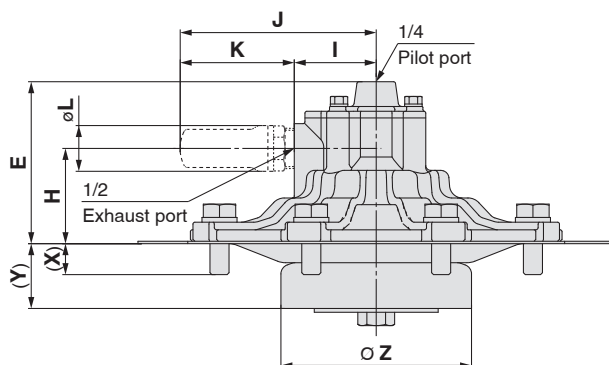

Note) Refer to page 32 for the dimensions of the mounting interface.

Dimensions

[mm]

Model	A	B	C	E	Y	X	H	I	J	K	L	Z
VXFA25B□	182	—	—	82	18.3	17	47	43	102.8 (94.6)	59.8 (43.1)	24 (17)	90
VXFA26B□	206	250	30	85	34	17	50	43	102.8 (94.6)	59.8 (43.1)	24 (17)	100
VXFA27B□	206	250	30	85	34	17	50	43	102.8 (94.6)	59.8 (43.1)	24 (17)	110
VXFA28B□	206	250	30	85	34	17	50	43	102.8 (94.6)	59.8 (43.1)	24 (17)	120

* (): When the symbol "D" for high temperature is selected.

Dimensions of the Mounting interface: Flange type

VXFA25B□□□

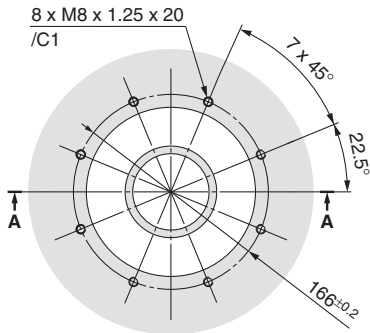

A-A

The surface roughness of the orifice should be Rz6.3 or less.

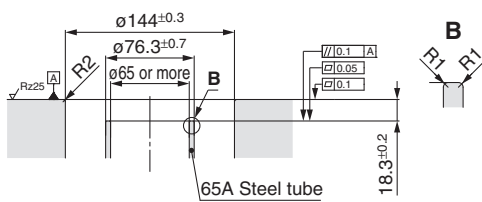

VXFA26B□□□

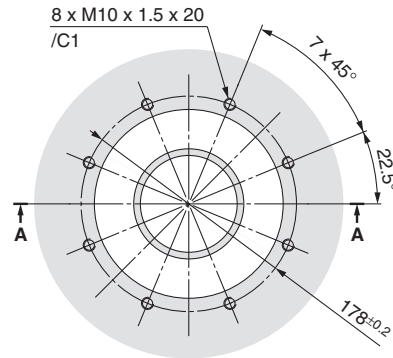

A-A

The surface roughness of the orifice should be Rz6.3 or less.

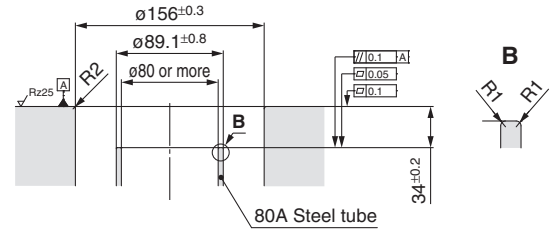

VXFA27B□□□

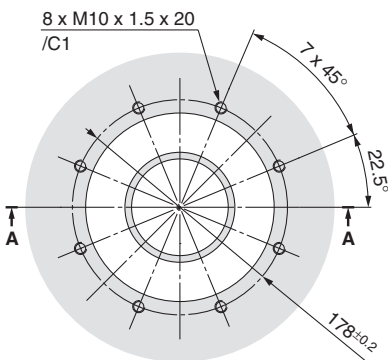

A-A

The surface roughness of the orifice should be Rz6.3 or less.

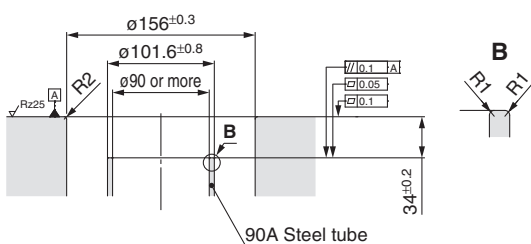

VXFA28B□□□

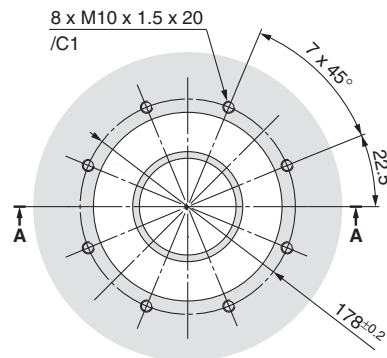

A-A

The surface roughness of the orifice should be Rz6.3 or less.

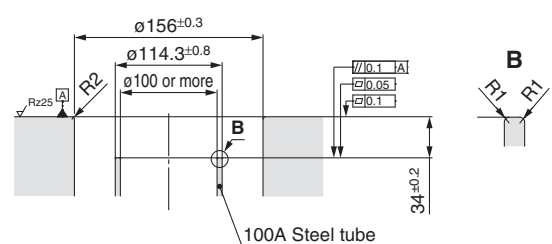

VXFA2 Series

Dimensions: **Flange body I/II type**

VXFA26C□□□□

VXFA26D□□□□

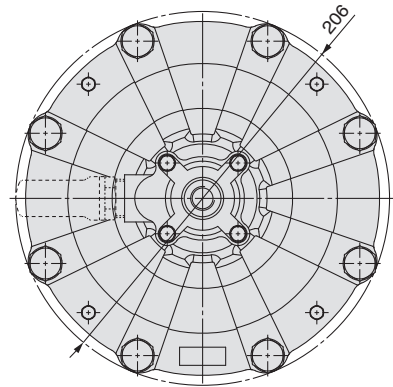
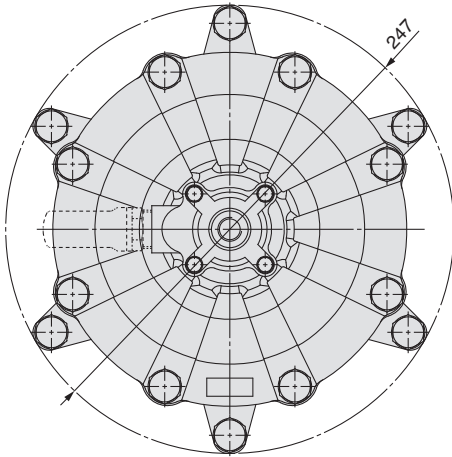
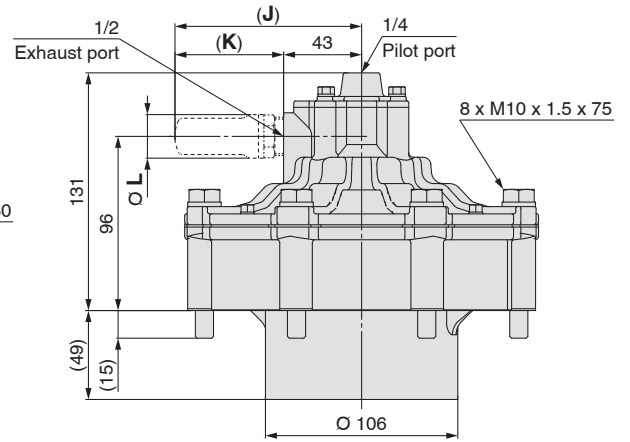
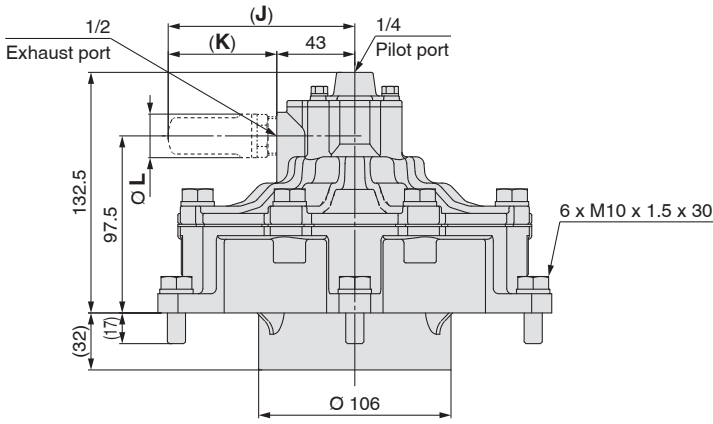

Note) Refer to page 34 for the dimensions of the mounting interface.

Dimensions of the Mounting interface: Flange body I/II type

VXFA26C□□□

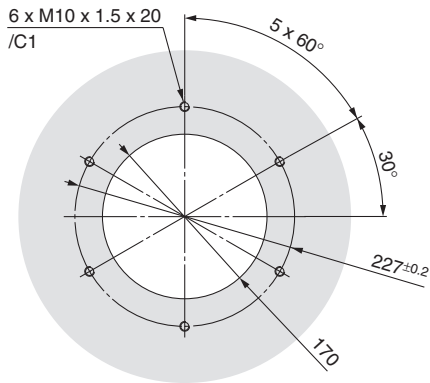

VXFA26D□□□

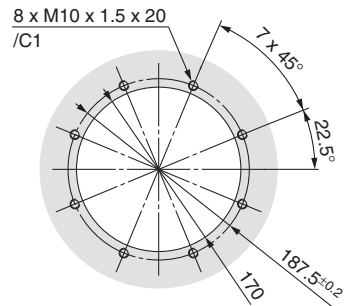

VXFA26C□□□ Piping

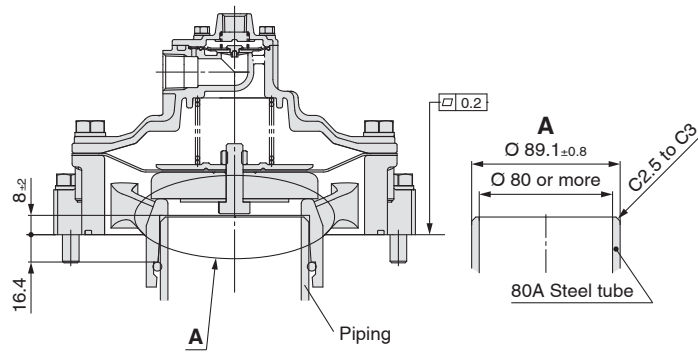

VXFA26D□□□ Piping

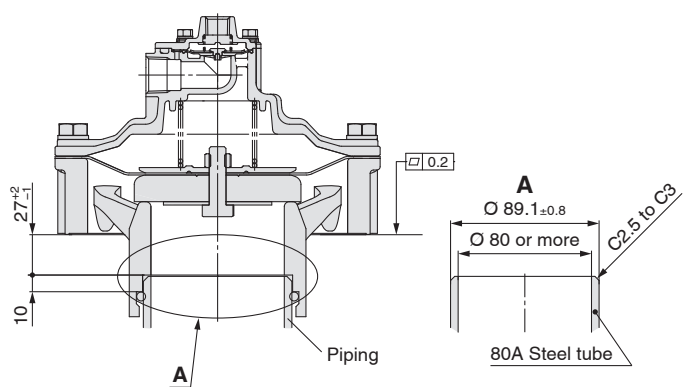

* Machine the mounting surface shape so that there are no gaps between the mounting surface and the product. Refer to page 38 for details.

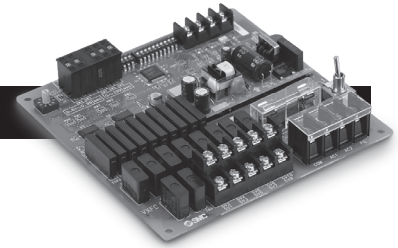

Dedicated Controller For Operation/VXFC Series

How to Order Controller

VXFC **06** **D** - **Q**

Number of outputs

06	6 outputs
10	10 outputs

Voltage

D	24 to 48 VDC
----------	--------------

Specifications

Model	VXFC ⁰⁶ ₁₀ D	
Input voltage	24 to 48 VDC	
Output voltage	Same as input voltage	
Time setting	ON	0.01 to 0.99 sec
	OFF	0 to 299 sec
	Time accuracy	±2 %
Number of outputs	6 to 10 points	
Operating ambient temperature	0 to 50 °C (No condensation allowed)	
Operating ambient humidity	45 to 80 % (No condensation allowed)	
Output current	0.3 A or less	
Power supply fuse	1 A	

[Application example]

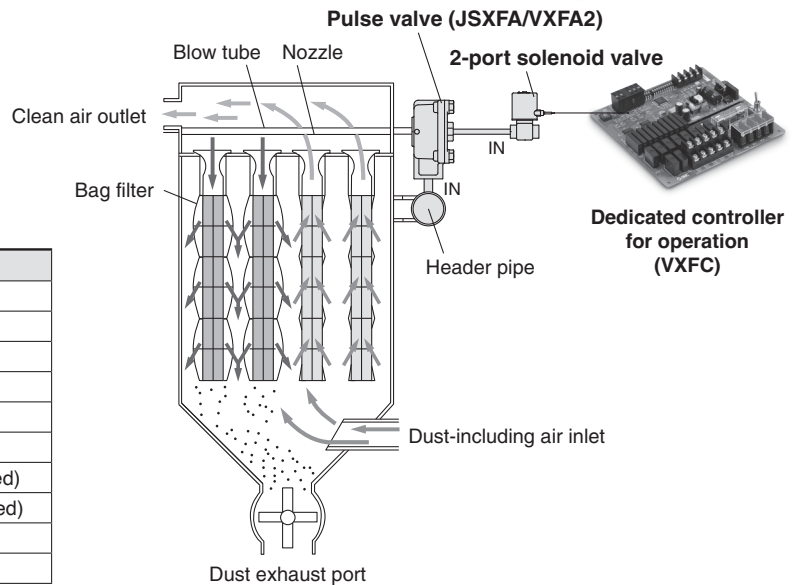

Two-time Hitting Function

A two-time hitting function has been adopted to improve the bag filter dusting efficiency. Turn ON the DIP switch for two-time hitting (OFF for one-time hitting).
(Effective for up to the number of set channels)

Operation sequence diagram

For

- 4 output points
- Two-time hitting only for CH2
- ON for 1 s
- OFF for 2 s

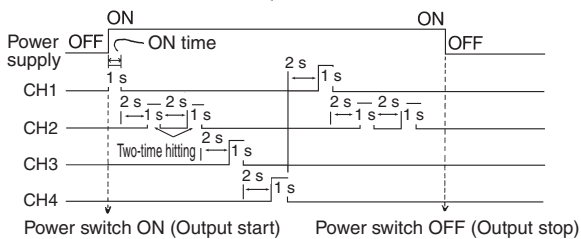

Interrupt Operation Function

Interrupting an operation via an external switch is possible using input signals.

Operation sequence diagram

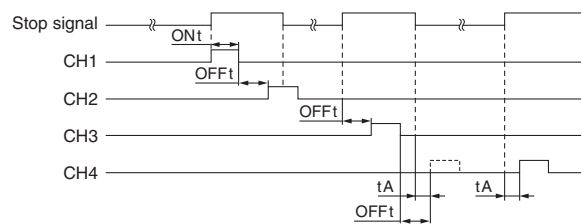

Cascade Connection (Multiple-board connection)

VXFC10: One board only allows 10 output points max., but the points can be increased to 20 or 30 output points by connecting cascades.

Connection

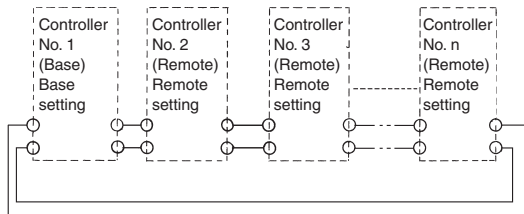

Operation sequence diagram

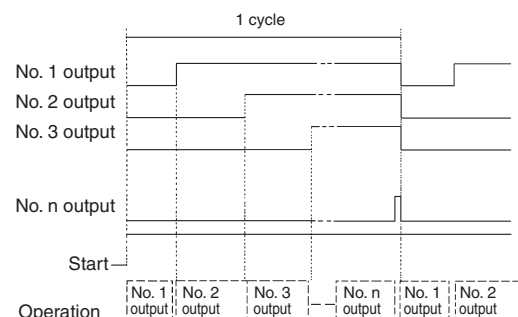

2 Port Solenoid Valve For Dust Collector *Series VXF2/VXFA2*

Dimensions

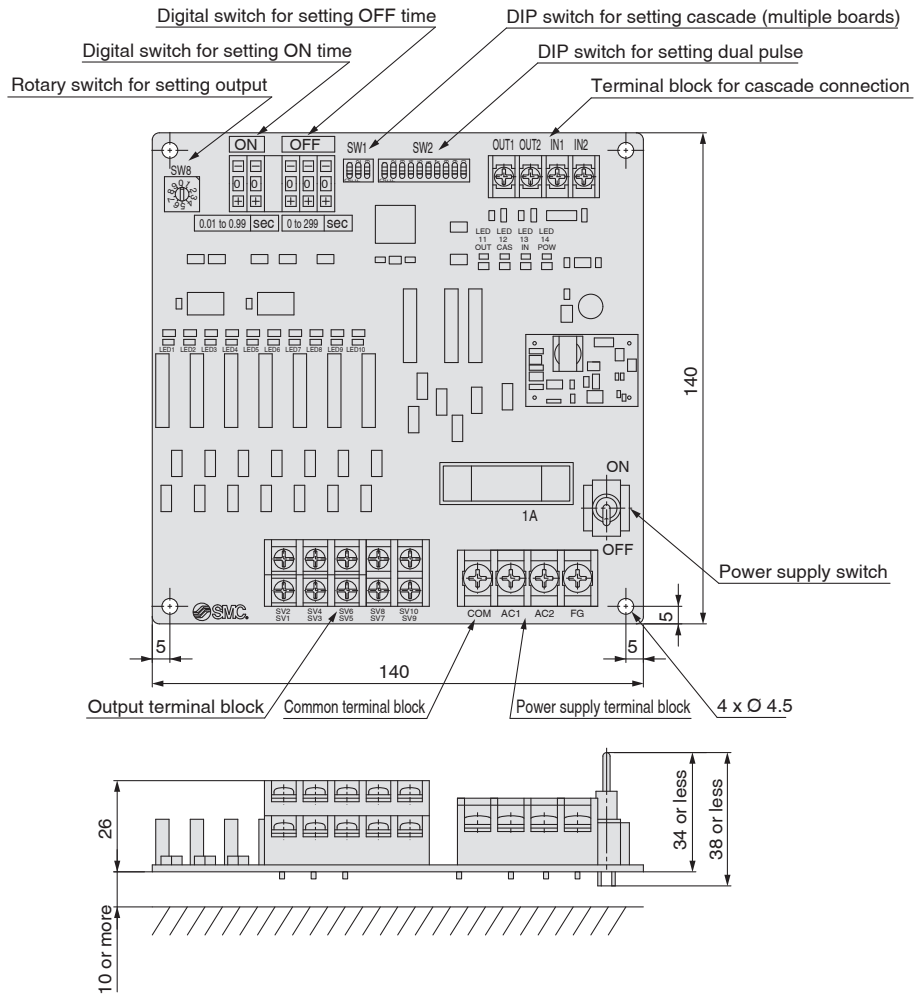

VXF(A) Series

Glossary of Terms

Pressure Terminology

1. Maximum operating pressure differential

The maximum pressure differential (the difference between the inlet and outlet pressure) which is allowed for operation. When the outlet pressure is 0 MPa, this becomes the maximum operating pressure.

2. Minimum operating pressure differential

The minimum pressure differential (the difference between the inlet pressure and outlet pressure) required to keep the main valve fully open.

3. Maximum system pressure

The maximum pressure that can be applied inside the pipelines (line pressure).

[The pressure differential of the solenoid valve portion must not exceed the maximum operating pressure differential.]

4. Withstand pressure

The pressure in which the valve must be withstood without a drop in performance after holding for one minute under prescribed pressure and returning to the operating pressure range. [value under the prescribed conditions]

Electrical Terminology

1. Apparent power (VA)

Volt-ampere is the product of voltage (V) and current (A).

Power consumption (W): For AC, $W = V \cdot A \cdot \cos \theta$.

For DC, $W = V \cdot A$.

Note) $\cos \theta$ shows power factor. $\cos \theta \approx 0.9$

2. Surge voltage

A high voltage which is momentarily generated by shutting off the power in the shut-off area.

3. Degree of protection

A degree defined in the "JIS C 0920: Waterproof test of electric machinery/appliance and the degree of protection against the intrusion of solid foreign objects."

Verify the degree of protection for each product.

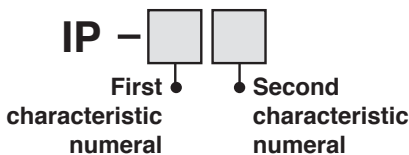

● First Characteristics:

Degrees of protection against solid foreign objects

0	Non-protected
1	Protected against solid foreign objects of 50 mm ϕ and greater
2	Protected against solid foreign objects of 12 mm ϕ and greater
3	Protected against solid foreign objects of 2.5 mm ϕ and greater
4	Protected against solid foreign objects of 1.0 mm ϕ and greater
5	Dust-protected
6	Dust-tight

Electrical Terminology

● Second Characteristics:

Degrees of protection against water

0	Non-protected	—
1	Protected against vertically falling water drops	Dripproof type 1
2	Protected against vertically falling water drops when enclosure tilted up to 15°	Dripproof type 2
3	Protected against rainfall when enclosure tilted up to 60°	Rainproof type
4	Protected against splashing water	Splashproof type
5	Protected against water jets	Water-jet-proof type
6	Protected against powerful water jets	Powerful water-jet-proof type
7	Protected against the effects of temporary immersion in water	Immersible type
8	Protected against the effects of continuous immersion in water	Submersible type

Example) IP65: Dust-tight, Water-jet-proof type

"Water-jet-proof type" means that no water intrudes inside an equipment that could hinder from operating normally by means of applying water for 3 minutes in the prescribed manner. Take appropriate protection measures, since a device is not usable in an environment where a droplet of water is splashed constantly.

Others

1. Material

NBR: Nitrile rubber

FKM: Fluoro rubber

2. Symbol

In the symbol , when the valve is closed, flow is blocked from port 1 to port 2. However, if the pressure in port 2 is higher than port 1, the valve will not be able to block the fluid and it will flow from port 2 to port 1.

Flat Terminal

1. Flat terminal/Electrical connection size of molded coil.

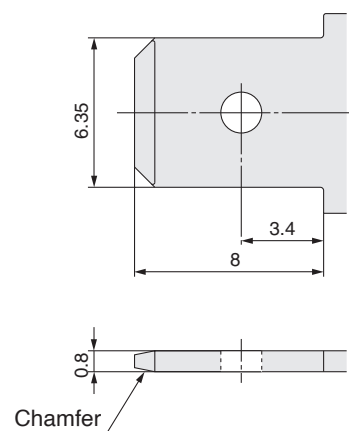



VXF2/VXFA2 Series

Specific Product Precautions 1

Be sure to read this before handling the products.
Refer to back cover for Safety Instructions.

2 Port Solenoid Valve For Dust Collector VXF2/VXFA2 Series

Design

Warning

- 1. Cannot be used as an emergency shutoff valve etc.**
The valves presented in this catalogue are not designed for safety applications such as an emergency shutoff valve. If the valves are used in this type of system, other reliable safety assurance measures should also be adopted.
- 2. Extended periods of continuous energisation**
This is a valve for pulse operation. Do not energize it continuously. Since a large amount of air is consumed, the diaphragm will oscillate (chatter) due to insufficient air supply on the inlet side, and this can lead to failure.
- 3. When the conduit type is used as equivalent to an IP65 enclosure, install a wiring conduit etc.**

Silencer

Caution

- The silencer's response properties do not change in the initial stage, but will change due to the blockage after long use. Replace it after using about 500,000 times. This number is subject to change based on fluid quality and energizing time.
- When using a silencer, make space for silencer replacement.

Selection

Warning

- 1. Air quality**
 - 1. Use clean air.**
Do not use compressed air that contains chemicals, synthetic oils including organic solvents, salt or corrosive gases, etc., as it can cause damage or malfunction.
 - 2. Install an air filter.**
Install an air filter close to the valve on the upstream side. A filtration degree of 5 μm or less should be selected.
 - 3. Install an aftercooler or air dryer, etc.**
Compressed air that contains excessive drainage may cause malfunction of valves and other pneumatic equipment. To prevent this, install an aftercooler or air dryer, etc.
 - 4. If excessive carbon powder is generated, eliminate it by installing a mist separator on the upstream side of valves.**
If excessive carbon powder is generated by the compressor, it may adhere to the inside of the valves and cause a malfunction.

Selection

Warning

- 2. Ambient environment**
Use within the allowable ambient temperature range. Check the compatibility between the product's composition materials and the ambient atmosphere. Be certain that the fluid used does not touch the external surface of the product.
- 3. Countermeasures against static electricity**
Take measures to prevent static electricity since some fluids can cause static electricity.
- 4. Low temperature operation**
 - The valve can be used in fluid temperatures down to -10 °C. However, take measures to prevent freezing or solidification of impurities, etc.
 - When using the valve in cold climates, take appropriate countermeasures to prevent freezing in tubing by draining the water etc. When warming by a heater etc., be careful not to expose the coil portion to a heater. Installation of a dryer, heat retaining of the body is recommended to prevent a freezing condition in which the dew point temperature is high and the ambient temperature is low, and the high flow runs.
- 5. Fluid properties**
Use a general compressed air with a filter of 5 μm or less mounted on the inlet of the piping. (Excluding dry air)

Caution

1. Leakage voltage

When the solenoid valve is operated using the controller, etc., the leakage voltage should be the product allowable leakage voltage or less. Particularly when using a resistor in parallel with a switching element and using a C-R element (surge voltage suppressor) to protect the switching element, take note that leakage current will flow through the resistor, C-R element, etc., creating a possible danger that the valve may not turn off.

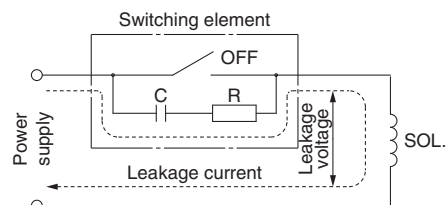

AC coil: 5 % or less of rated voltage
DC coil: 2 % or less of rated voltage

- The response performance and start-up speed of air operated type (VXFA2) is slower compared to the solenoid type (VXF2). Refer to the data for pilot piping.
- Note that for DC, idle time and return time increase if the voltage is lowered. If a surge voltage suppressor is installed, the return speed decreases.



VXF2/VXFA2 Series

Specific Product Precautions 2

Be sure to read this before handling the products.
Refer to back cover for Safety Instructions.

2 Port Solenoid Valve For Dust Collector VXF2/VXFA2 Series

Mounting

⚠ Warning

- 1. If air leakage increases or equipment does not operate properly, stop operation.**
After mounting is completed, confirm that it has been done correctly by performing a suitable function test.
- 2. Do not apply external force to the coil section.**
When tightening is performed, apply a wrench or other tool to the outside of the piping connection parts.
- 3. Mount a valve with its coil position upward, not downward.**
When mounting a valve with its coil position downward, foreign objects in the fluid will adhere to the iron core leading to a malfunction. Especially for strict leakage control, such as with vacuum applications and non-leak specifications, the coil must be positioned upward.
- 4. Do not warm the coil assembly with a heat insulator etc.**
Use tape, heaters, etc., for freeze prevention on the piping and body only. They can cause the coil to burn out.
- 5. Avoid sources of vibration, or adjust the arm from the body to the minimum length so that resonance will not occur.**
- 6. Painting and coating**
Warnings or specifications printed or labeled on the product should not be erased, removed or covered up.

⚠ Caution

- 1. Machine the mounting surface shape so that there are no gaps between the mounting surface and the product.**

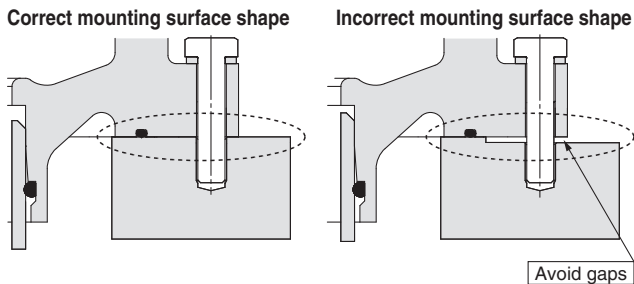

Piping

⚠ Warning

- 1. During use, deterioration of the tube or damage to the fittings could cause tubes to come loose from their fittings and thrash about.**
To prevent uncontrolled tube movement, install protective covers or fasten tubes securely in place.
- 2. For piping the tube, fix the product securely using the mounting holes so that the product is not in the air.**

Piping

⚠ Caution

- 1. Preparation before piping**
Before piping is connected, it should be thoroughly blown out with air (flushing) or washed to remove chips, cutting oil and other debris from inside the pipe.
Install piping so that it does not apply pulling, pressing, bending or other forces on the valve body.
- 2. Avoid connecting ground lines to piping, as this may cause electric corrosion of the system.**
- 3. Always tighten threads with the proper tightening torque.**
When attaching fittings to valves, tighten with the proper tightening torque shown below.

Tightening Torque for Piping

Connection thread	Proper tightening torque N·m	Connection thread	Proper tightening torque N·m
Rc1/4	12 to 14	Rc1 1/2	40 to 42
Rc3/8	22 to 24	Rc2	48 to 50
Rc1/2	28 to 30	Rc2 1/2	48 to 50
Rc3/4	28 to 30	Rc3	48 to 50
Rc1	36 to 38		

- 4. When connecting piping to a product**
Avoid mistakes regarding the supply port etc.
- 5. If a regulator, or a restrictor, is installed immediately before or after the IN port of the valve, the main valve may oscillate (chatter). Install them away from the valve or change the restriction.**
- 6. The header tank capacity should be sufficient. This is a valve for large flow rate, so if the capacity is small, the main valve may oscillate due to pressure drop or insufficient air supply.**

Wiring

⚠ Warning

- 1. The solenoid valve is an electrical product. For safety, install an appropriate fuse and circuit breaker before use.**
When using multiple solenoid valves, it is not sufficient to merely install one fuse on the inlet side. In order to ensure the safety of the devices, select and install a fuse for each circuit.

⚠ Caution

- 1. As a rule, use electrical wire with a cross sectional area of 0.5 to 1.25 mm² for wiring.**
Furthermore, do not allow excessive force to be applied to the lines.
- 2. Use electrical circuits which do not generate chattering in their contacts.**
- 3. Use voltage which is within ±10 % of the rated voltage. In cases with a DC power supply where importance is placed on responsiveness, stay within ±5 % of the rated value. The voltage drop is the value in the lead wire section connecting the coil.**
- 4. When a surge from the solenoid affects the electrical circuitry, install a surge voltage suppressor etc. in parallel with the solenoid. Or, adopt an option that comes with the surge voltage protection circuit. (However, a surge voltage occurs even if the surge voltage protection circuit is used.)**



VXF2/VXFA2 Series

Specific Product Precautions 3

Be sure to read this before handling the products.
Refer to back cover for Safety Instructions.

2 Port Solenoid Valve For Dust Collector VXF2/VXFA2 Series

Operating Environment

Warning

1. Do not use in an atmosphere having corrosive gases, chemicals, sea water, water, water vapor, or where there is direct contact with any of these.
2. Do not use in explosive atmospheres.
3. Do not use in locations subject to vibration or impact.
4. Do not use in locations where radiated heat will be received from nearby heat sources.
5. Employ suitable protective measures in locations where there is contact with water droplets, oil or welding spatter, etc.

Maintenance

Warning

1. Removing the product

The valve becomes hot depending on the fluid temperature. Confirm that the valve temperature has dropped sufficiently before performing work. If touched inadvertently, there is a danger of being burned.

1. Shut off the fluid supply and release the fluid pressure in the system.
2. Shut off the power supply.
3. Remove the product.

2. Low frequency operation

Switch valves at least once every 30 days to prevent malfunction. Also, in order to use it under the optimum state, conduct a regular inspection once a half year.

Caution

1. Filters

1. Be careful regarding clogging of filters.
2. Replace filter elements after one year of use, or earlier if the pressure drop reaches 0.1 MPa.

2. Storage

In case of long term storage after use, thoroughly remove all moisture to prevent rust and deterioration of rubber materials etc.

3. Exhaust the drainage from an air filter periodically.

Electrical Connections

Caution

Grommet

Class B coil: AWG20 Outside insulator diameter of 2.5 mm

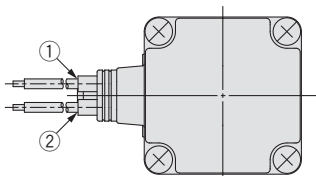

Rated voltage	Lead wire color	
	①	②
DC	Black	Red
100 VAC	Blue	Blue
200 VAC	Red	Red
Other AC	Gray	Gray

* There is no polarity.

Electrical Connections

Caution

DIN terminal

Disassembly

1. After loosening the binding head screw with flange, then if the housing is pulled in the direction of the arrow, the connector will be removed from the solenoid valve.
2. Pull out the binding head screw with flange from the housing.
3. There is a cutout on the bottom of the terminal block. Insert a small flat head screwdriver, etc. into this cutout, and remove the terminal block from the housing. (See figure below.)
4. Remove the ground nut, and pull out the washer and the rubber seal.

Wiring

1. Pass the cable through the ground nut, washer and rubber seal in this order, and insert these parts into the housing.
2. Loosen the binding head screw of the terminal block, then insert the core wire or the crimped terminal of the lead wire into the terminal, and securely fix it with the binding head screw. The binding head screw of the terminal block is M3.
Note 1) Tighten the screw to a torque of between 0.5 and 0.6 N·m.
Note 2) Cable O.D.: $\phi 6$ to $\phi 12$ mm
Note 3) For an outside cable diameter of $\phi 9$ to 12 mm, remove the internal parts of the rubber seal before using.

Assembly

1. Pass the cable through the ground nut, washer, rubber seal and the housing in this order, and connect to the terminal block. Then, set the terminal block inside the housing. (Push in the terminal block until it snaps into position.)
2. Insert the rubber seal and the washer in this order into the cable entry of the housing, and then tighten the ground nut securely.
3. Insert the gasket between the bottom part of the terminal block and the plug attached to the equipment, and then insert the binding head screw with flange from the top of the housing, and tighten it.
Note 1) Tighten the screw to a torque of between 0.5 and 0.6 N·m.
Note 2) The orientation of the connector can be changed in steps of 90° by changing the method of assembling the housing and the terminal block.

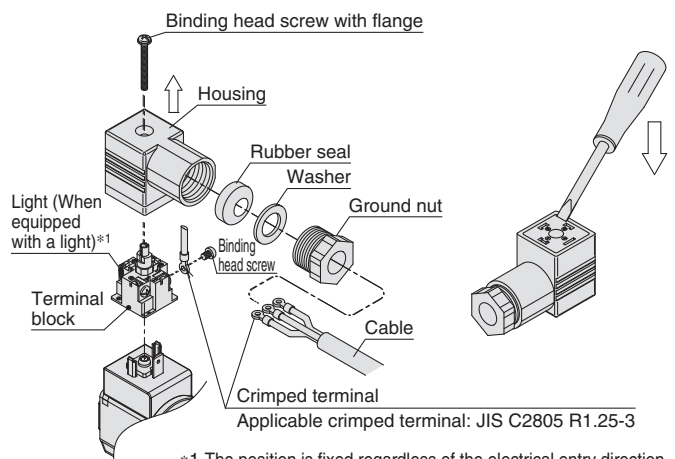

*1 The position is fixed regardless of the electrical entry direction.



VXF2/VXFA2 Series

Specific Product Precautions 4

Be sure to read this before handling the products.
Refer to back cover for Safety Instructions.

2 Port Solenoid Valve For Dust Collector VXF2/VXFA2 Series

Electrical Connections

⚠ Caution

Internal connections are as shown below. Make connections to the power supply accordingly.

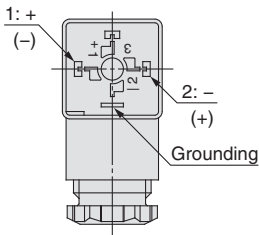

Terminal no.	1	2
DIN terminal	+ (-)	- (+)

* There is no polarity.

DIN (EN175301-803) Terminal

This DIN terminal corresponds to the Form A DIN connector with an 18 mm terminal pitch, which complies with EN175301-803B.

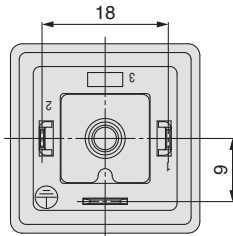

■ Conduit terminal

Disassembly

1. Loosen the mounting screw, and remove the terminal cover from the conduit terminal.

Wiring

1. Insert the cable into the conduit terminal.
2. Loosen the screw with UP terminal of the conduit terminal, then insert the core wire or the crimped terminal of the lead wire into the terminal, and securely fix it with the screw with UP terminal.
Note 1) Tighten the screw to a torque of between 0.5 and 0.6 N·m.

⚠ Caution

■ Conduit terminal

Assembly

1. Insert the gasket into the conduit terminal, and then clamp the terminal cover with the mounting screw.

Note 1) Tighten the screw to a torque of between 0.5 and 0.6 N·m.
Note 2) When changing the orientation of the conduit terminal, carry out the following procedure.

1. Apply a tool (monkey wrench, spanner, etc.) to the width across flats of the conduit terminal, and turn the terminal in the counterclockwise direction.
2. Loosen the lock nut.
3. Turn the conduit terminal in the clamping direction (clockwise direction) to about 15° ahead of the desired position.
4. Turn the lock nut by hand to the coil side until it is lightly tightened.
5. Apply a tool to the width across flats of the conduit terminal, and turn it to the desired position (through an angle of about 15°) so as to clamp the conduit terminal.

Note) When changing the orientation by applying additional tightening force to the conduit terminal from the factory-set position, turn no more than one half a turn.

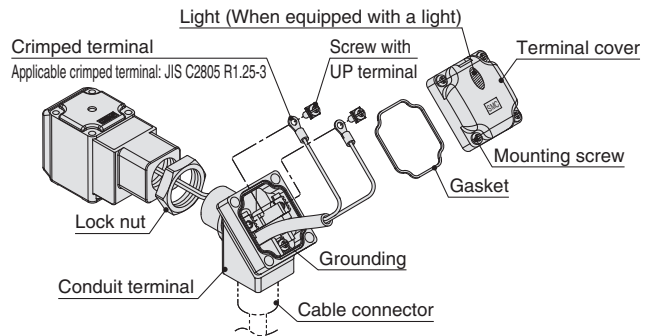

Make connections according to the marks shown below.

- Use the tightening torques below for each section.
- Properly seal the terminal connection (G1/2) with the special wiring conduit etc.

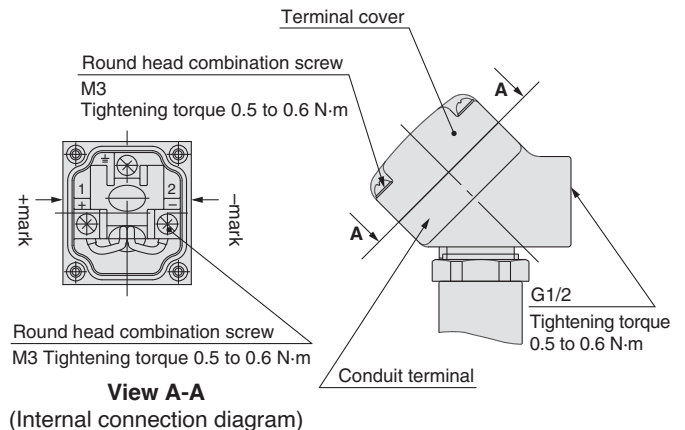



VXF2/VXFA2 Series

Specific Product Precautions 5

Be sure to read this before handling the products.
Refer to back cover for Safety Instructions.

2 Port Solenoid Valve For Dust Collector VXF2/VXFA2 Series

Electrical Connections

⚠ Caution

■ Conduit

When used as an IP65 equivalent, use seal to install the wiring conduit. Also, use the tightening torque below for the conduit.

Class B coil: AWG20 Outside insulator diameter of 2.5 mm

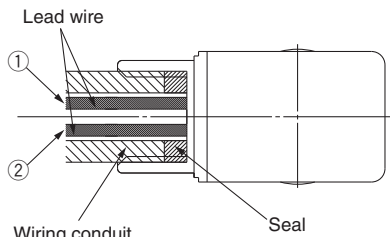

(Port size G1/2 Tightening torque 0.5 to 0.6 N·m)

Rated voltage	Lead wire color	
	①	②
DC	Black	Red
100 VAC	Blue	Blue
200 VAC	Red	Red
Other AC	Grey	Grey

* There is no polarity.

Description	Part no.
Seal	VCW20-15-6

Note) Please order separately.

Electrical Circuits

⚠ Caution

[DC circuit]

Grommet, Flat terminal

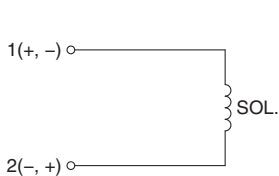

Without electrical option

Grommet, DIN terminal, Conduit terminal, Conduit

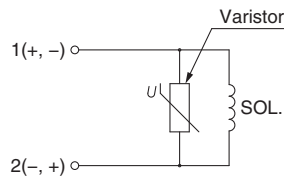

With surge voltage suppressor

DIN terminal, Conduit terminal

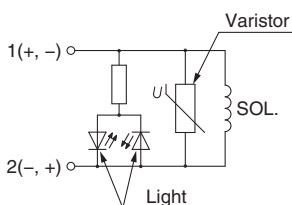

With light and surge voltage suppressor

2 Port Solenoid Valve For Dust Collector VXF2/VXFA2 Series

Electrical Circuits

⚠ Caution

[AC circuit]

Grommet, DIN terminal Conduit terminal, Conduit

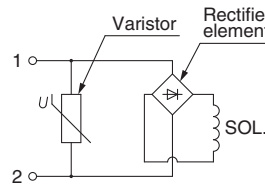

Without electrical option

DIN terminal, Conduit terminal

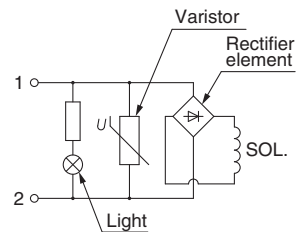

With light and surge voltage suppressor

Dedicated Controller For Operation VXFC Series

Wiring

⚠ Warning

1. The controller starts its output the moment the power switch is turned ON. Be aware that even if the power switch is turned OFF, power is connected to the terminal block.

⚠ Caution

1. Make sure that the power supply voltage to be input matches the voltage in the controller's specifications. The power supply voltage that has been input becomes the voltage that is output to the solenoid valves.
2. Connect a ground that is rated Class 3 or greater to the power supply terminal block's FG.
3. If the power source is DC, use caution to its polarity. If the polarity is incorrect, it may result in a malfunction or damage.
4. For details, refer to the separate Operation Manual.
5. The solenoid valve mounted on the controller should be equipped with a surge voltage suppressor.



Operating Environment

⚠ Warning

1. Operate under conditions that are free of vibration and impact.
2. Operate in an ambient temperature range between 0 °C and 50 °C.
3. Operate in an ambient humidity range between 45 % to 85 % (with no condensation).

Safety Instructions

These safety instructions are intended to prevent hazardous situations and/or equipment damage. These instructions indicate the level of potential hazard with the labels of “Caution,” “Warning” or “Danger.” They are all important notes for safety and must be followed in addition to International Standards (ISO/IEC)¹⁾, and other safety regulations.

 Danger:	Danger indicates a hazard with a high level of risk which, if not avoided, will result in death or serious injury.
 Warning:	Warning indicates a hazard with a medium level of risk which, if not avoided, could result in death or serious injury.
 Caution:	Caution indicates a hazard with a low level of risk which, if not avoided, could result in minor or moderate injury.

- 1) ISO 4414: Pneumatic fluid power – General rules and safety requirements for systems and their components.
ISO 4413: Hydraulic fluid power – General rules and safety requirements for systems and their components.
IEC 60204-1: Safety of machinery – Electrical equipment of machines. (Part 1: General requirements)
ISO 10218-1: Robots and robotic devices - Safety requirements for industrial robots - Part 1: Robots.
etc.

Warning

1. The compatibility of the product is the responsibility of the person who designs the equipment or decides its specifications.

Since the product specified here is used under various operating conditions, its compatibility with specific equipment must be decided by the person who designs the equipment or decides its specifications based on necessary analysis and test results. The expected performance and safety assurance of the equipment will be the responsibility of the person who has determined its compatibility with the product. This person should also continuously review all specifications of the product referring to its latest catalogue information, with a view to giving due consideration to any possibility of equipment failure when configuring the equipment.

2. Only personnel with appropriate training should operate machinery and equipment.

The product specified here may become unsafe if handled incorrectly. The assembly, operation and maintenance of machines or equipment including our products must be performed by an operator who is appropriately trained and experienced.

3. Do not service or attempt to remove product and machinery/equipment until safety is confirmed.

1. The inspection and maintenance of machinery/equipment should only be performed after measures to prevent falling or runaway of the driven objects have been confirmed.
2. When the product is to be removed, confirm that the safety measures as mentioned above are implemented and the power from any appropriate source is cut, and read and understand the specific product precautions of all relevant products carefully.
3. Before machinery/equipment is restarted, take measures to prevent unexpected operation and malfunction.

4. Our products cannot be used beyond their specifications.

Our products are not developed, designed, and manufactured to be used under the following conditions or environments.

Use under such conditions or environments is not covered.

1. Conditions and environments outside of the given specifications, or use outdoors or in a place exposed to direct sunlight.
2. Use for nuclear power, railways, aviation, space equipment, ships, vehicles, military application, equipment affecting human life, body, and property, fuel equipment, entertainment equipment, emergency shut-off circuits, press clutches, brake circuits, safety equipment, etc., and use for applications that do not conform to standard specifications such as catalogues and operation manuals.
3. Use for interlock circuits, except for use with double interlock such as installing a mechanical protection function in case of failure. Please periodically inspect the product to confirm that the product is operating properly.

Caution

We develop, design, and manufacture our products to be used for automatic control equipment, and provide them for peaceful use in manufacturing industries.

Use in non-manufacturing industries is not covered.

Products we manufacture and sell cannot be used for the purpose of transactions or certification specified in the Measurement Act.

The new Measurement Act prohibits use of any unit other than SI units in Japan.

Limited warranty and Disclaimer/Compliance Requirements

The product used is subject to the following “Limited warranty and Disclaimer” and “Compliance Requirements”. Read and accept them before using the product.

Limited warranty and Disclaimer

1. The warranty period of the product is 1 year in service or 1.5 years after the product is delivered, whichever is first.²⁾ Also, the product may have specified durability, running distance or replacement parts. Please consult your nearest sales branch.
 2. For any failure or damage reported within the warranty period which is clearly our responsibility, a replacement product or necessary parts will be provided. This limited warranty applies only to our product independently, and not to any other damage incurred due to the failure of the product.
 3. Prior to using SMC products, please read and understand the warranty terms and disclaimers noted in the specified catalogue for the particular products.
- 2) Vacuum pads are excluded from this 1 year warranty.
A vacuum pad is a consumable part, so it is warranted for a year after it is delivered. Also, even within the warranty period, the wear of a product due to the use of the vacuum pad or failure due to the deterioration of rubber material are not covered by the limited warranty.

Compliance Requirements

1. The use of SMC products with production equipment for the manufacture of weapons of mass destruction (WMD) or any other weapon is strictly prohibited.
2. The exports of SMC products or technology from one country to another are governed by the relevant security laws and regulations of the countries involved in the transaction. Prior to the shipment of a SMC product to another country, assure that all local rules governing that export are known and followed.

Safety Instructions

Be sure to read “Handling Precautions for SMC Products” (M-E03-3) before using.

SMC Corporation (Europe)

Austria	+43 (0)2262622800	www.smc.at	office.at@smc.com
Belgium	+32 (0)33551464	www.smc.be	info@smc.be
Bulgaria	+359 (0)2807670	www.smc.bg	sales.bg@smc.com
Croatia	+385 (0)13707288	www.smc.hr	sales.hr@smc.com
Czech Republic	+420 541424611	www.smc.cz	office.at@smc.com
Denmark	+45 70252900	www.smc.dk.com	smc.dk@smc.com
Estonia	+372 651 0370	www.smcee.ee	info.ee@smc.com
Finland	+358 207513513	www.smc.fi	smc.fi@smc.com
France	+33 (0)164761000	www.smc-france.fr	supportclient.fr@smc.com
Germany	+49 (0)61034020	www.smc.de	info.de@smc.com
Greece	+30 210 2717265	www.smchellas.gr	sales@smchellas.gr
Hungary	+36 23513000	www.smc.hu	office.hu@smc.com
Ireland	+353 (0)14039000	www.smcautomation.ie	technical.ie@smc.com
Italy	+39 03990691	www.smcitalia.it	mailbox.it@smc.com
Latvia	+371 67817700	www.smc.lv	info.lv@smc.com

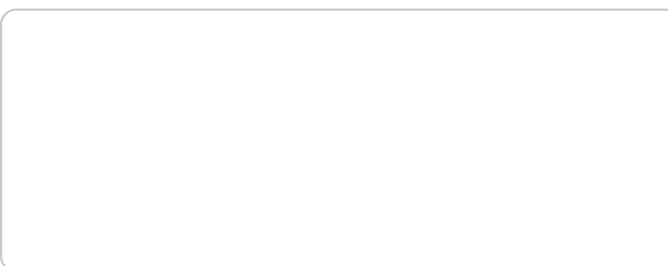

Lithuania	+370 5 2308118	www.smclt.lt	info.lt@smc.com
Netherlands	+31 (0)205318888	www.smc.nl	info@smc.nl
Norway	+47 67129020	www.smc-norge.no	post.no@smc.com
Poland	+48 22 344 40 00	www.smc.pl	office.pl@smc.com
Portugal	+351 214724500	www.smc.eu	apoiocliente.pt@smc.com
Romania	+40 213205111	www.smcromania.ro	office.ro@smc.com
Russia	+7 (812)3036600	www.smc.eu	sales@smcru.com
Slovakia	+421 (0)413213212	www.smc.sk	sales.sk@smc.com
Slovenia	+386 (0)73885412	www.smc.si	office.si@smc.com
Spain	+34 945184100	www.smc.eu	post.es@smc.com
Sweden	+46 (0)86031240	www.smc.nu	order.se@smc.com
Switzerland	+41 (0)523963131	www.smc.ch	helpcenter.ch@smc.com
Turkey	+90 212 489 0 440	www.smcturkey.com.tr	satis@smcturkey.com.tr
UK	+44 (0)845 121 5122	www.smc.uk	sales.gb@smc.com
South Africa	+27 10 900 1233	www.smcza.co.za	Sales.za@smc.com