

2/3 Port Valve for Various Fluids Control



■ 2/3 Port Solenoid/Air Operated Valve for Various Fluids Control
(For Water/Air/Oil/Gas/Vacuum/Steam)

□ 2/3 Port Solenoid Valve

- Direct operated 2 port solenoid valve: **VX21/22/23** 17-3-17
- Pilot operated 2 port solenoid valve: **VXD21/22/23** 17-3-33
- Pilot operated 2 port solenoid valve: **VXP21/22/23** 17-3-43
- Water hammer relief, pilot operated 2 port solenoid valve: **VXR21/22/23** ... 17-3-53
- Pilot operated 2 port solenoid valve
for zero pressure differential operation: **VXZ**..... 17-3-61
- Pilot operated 2 port solenoid valve for high pressure: **VXH**..... 17-3-69
- 2 port solenoid valve for dust collector: **VXF**..... 17-3-71
- Direct operated 3 port solenoid valve: **VX31/32/33** 17-3-81

□ 2/3 Port Air Operated Valve

- Direct air operated 2 port valve: **VXA21/22**..... 17-3-93
- Direct air operated 2 port valve: **VXA31/32**..... 17-3-101

The models VX21/22/23 have been revised. For details, please refer to catalog no. ES70-23A.
The models VX31/32/33 have been revised. For details, please refer to catalog no. ES70-26A.
Similar updating for other VX* series are scheduled to follow shortly.

VC□

VDW

VQ

VX2

VX□

VX3

VXA

VN□

LVC

LVA

LVH

LVD

LVQ

LQ

LVN

TI/
TIL

PA

PAX

PB

For Fluid Control

2/3 Port Valve

Solenoid Valve/Air Operated Valve

For Water, Air, Oil, Gas, Vacuum and Steam

2 Port, Direct Operated

Series VX21/22/23

N.C., N.O./ Single unit, Manifold

Refer to our catalog "ES70-23A".

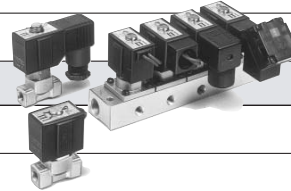

2 Port, Pilot Operated (Diaphragm type)

Series VXD21/22/23

N.C., N.O.

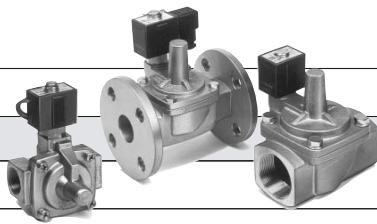
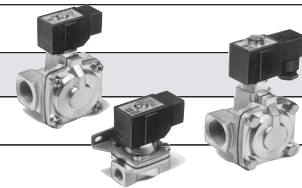

2 Port, Pilot Operated (Disk type)

Series VXP21/22/23

N.C., N.O.

2 Port, Pilot Operated

Series VXR21/22/23

< Water hammer relief > N.C., N.O.

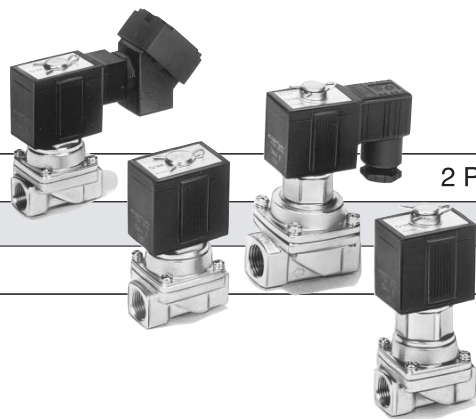
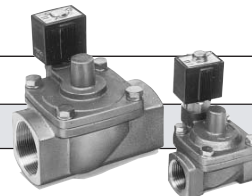

2 Port, Pilot Operated (Diaphragm type, zero pressure differential operation)

Series VXZ22/23

N.C., N.O./ Single unit

The models VX21/22/23 have been revised. For details, please refer to catalog no. ES70-23A.
 The models VX31/32/33 have been revised. For details, please refer to catalog no. ES70-26A.
 Similar updating for other VX* series are scheduled to follow shortly.

Series VX

2 Port, Pilot Operated

Series VXH22

For high pressure control N.C./Single unit

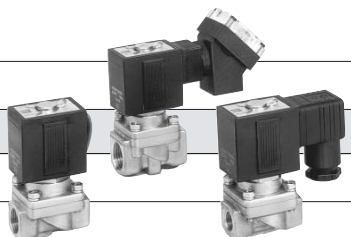

Selection Procedure for 2/3 Port Valve for Fluid Control

1. Selection of the series

Select series by referring to the number of ports, valve type (N.C., N.O., C.O.), port size and applied fluid.

2. Check by the applicable fluids check list



Use the tables on pages 17-3-6 to -14 to check the compatibility of the applicable fluid with the solenoid valve.

3. Confirmation of the working pressure differential

There are two types of pressure differentials. The high pressure differential is the highest pressure difference allowable between the inlet side and the outlet side in an open and closed state. The minimum pressure differential is the lowest pressure required to hold the main valve fully open. Refer to the following pages for each series as the pressure differential varies with the orifice size, power supply, pressure and fluid.

4. Reference to the flow characteristic table

To obtain the flow rate of fluid, refer to the flow characteristic table.

5. Choice of the power supply voltage and electrical entry

Select the AC/DC power source and choose the electrical entry.

VC

VDW

VQ

VX2

VX

VX3

VXA

VN

LVC

LVA

LVH

LVD

LVQ

LQ

LVN

TI/TIL

PA

PAX

PB

2 Port, Pilot Operated

Series VXF21/22

Quick response, Control of instantaneous large flow N.C./Single unit

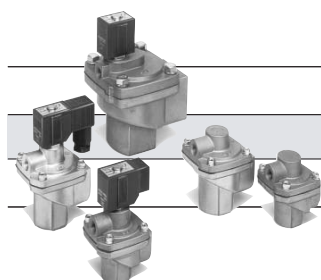

3 Port, Direct Operated

Series VX31/32/33

C.O./Single unit, Manifold

Refer to our catalog "ES70-26A".

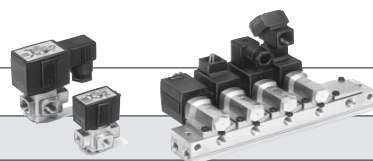

Air Operated Valve

2/3 Port, Direct Operated

Series VXA21/22

Series VXA31/32

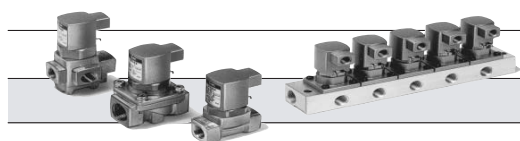

The models VX21/22/23 have been revised. For details, please refer to catalog no. ES70-23A. The models VX31/32/33 have been revised. For details, please refer to catalog no. ES70-26A. Similar updating for other VX* series are scheduled to follow shortly.

Solenoid Valves List

Number of ports		2 port									
Action	Direct operated				Pilot operated Diaphragm type		Pilot operated Disk type		Pilot operated <Water hammer relief>		
Series	VX21/22/23				VXD21/22/23		VXP21/22/23		VXR21/22/23		
Body type	Single unit		Manifold		Single unit		Single unit		Single unit		
Valve type	N.C.	N.O.	N.C.	N.O.	N.C.	N.O.	N.C.	N.O.	N.C.	N.O.	
Applicable fluids	Standard	Water	●	—	—	—	●	●	●	—	
		Air	●	●	●	●	●	●	—	—	
		Oil	●	●	●	●	●	●	●	—	
		Low vacuum (1 Torr)	●	●	—	—	—	—	—	—	
	Option	Steam	●	—	—	—	—	●	—	—	
		Medium vacuum (10 ⁻³ Torr)	●	●	—	—	—	—	—	—	
		Non-leak (10 ⁻⁵ atm cc/sec)	●	●	—	—	—	—	—	—	
	High temperature water, High temperature oil	●	—	—	—	●	●	●	●		
Port size	Rc	1/8 (6A)	●	●	—	—	—	—	—	—	
		1/4 (8A)	●	●	—	—	●	—	—	—	
		3/8 (10A)	●	●	—	—	●	—	—	—	
		1/2 (15A)	●	—	—	—	●	●	●	●	●
		3/4 (20A)	—	—	—	—	●	●	●	●	●
	Flange Rc	1 (25A)	—	—	—	—	●	●	●	●	●
		1 1/4 (32A)	—	—	—	—	●	●	●	●	●
		1 1/2 (40A)	—	—	—	—	●	●	●	●	●
		2 (50A)	—	—	—	—	●	●	●	●	●
			—	—	—	—	●	●	●	●	●

Page Catalog ES70-23A 17-3-17 17-3-27 17-3-37

Air Operated Valves List





* An option is available that sets the orifice in the vacuum side to the maximum bore for exclusive use when used in a vacuum pad application. Refer to page 17-3-86 for details.

Number of ports		2 port				3 port	
Action	Direct operated				Direct operated		
Series	VXA21/22				VXA31/32		
Body type	Single unit		Manifold		Single unit	Manifold	
Valve type	N.C.	N.O.	N.C.	N.O.	C.O.	C.O.	
Applicable fluids	Standard	Water	●	—	—	—	
		Air	●	●	●	●	
		Oil	●	●	●	●	
		Low vacuum (1 Torr)	●	●	●	●	
Option	Medium vacuum (10 ⁻³ Torr)		●		●	●	
	Non-leak (10 ⁻⁵ atm cc/sec)		●		●	●	
Port size	Rc	1/8 (6A)	●	●	—	—	
		1/4 (8A)	●	●	—	—	
		3/8 (10A)	●	●	—	—	
		1/2 (15A)	●	●	—	—	

Page 17-3-45 17-3-49 17-3-53 17-3-57

2 port				3 port			
Pilot operated <Zero pressure differential operation>		Pilot operated <High pressure control>		Pilot operated <Quick response, Instantaneous large flow>		Direct operated	
VXZ22/23		VXH22		VXF21/22		VX31/32/33	
Single unit		Single unit		Single unit		Single unit	Manifold
N.C.	N.O.	N.C.	N.C.	N.C.	N.C.	N.C./N.O./C.O.	N.C./N.O./C.O.
●	●	●	—	●	—		
●	●	●	●	●	●		
●	●	●	—	●	●		
●	—	—	—	●*	●		
—	—	—	—	●	—		
—	—	—	—	●	●		
●	—	—	—	●	—		
—	—	—	—	●	—		
●	●	●	—	●	—		
●	●	●	—	●	—		
●	●	●	—	●	—		
●	●	—	●	—	—		
●	●	—	●	—	—		
—	—	—	—	—	—		
—	—	—	—	—	—		
—	—	—	—	—	—		
—	—	—	—	● Rc	—		
—	—	—	—	—	—		
17-3-61		17-3-69		17-3-71		Catalog ES70-26A	

- VC
- VDW
- VQ
- VX2
- VX
- VX3
- VXA
- VN
- LVC
- LVA
- L VH
- LVD
- LVQ
- LQ
- LVN
- TI/
TIL
- PA
- PAX
- PB

- 
Applicable fluids check list
17-3-6
to
17-3-14
- 
Glossary
17-3-15
- 
How to order
Solenoid coil assembly
17-3-16

⚠ Caution
 Be sure to read before handling. Refer to pages 17-6-3 to 17-6-10 for Safety Instructions and Solenoid Valve Precautions.

Applicable Fluids Check List

Direct Operated 3 Port Solenoid Valve Series VX31/32/33

Normally Closed (N.C.), Normally Open (N.O.), Common (C.O.)



Refer to our catalog ES70-26A for specifications and models.

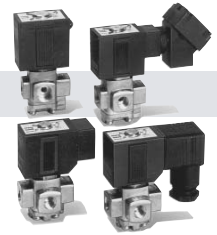

Option Symbol and Composition

Option symbol	Seal material	Coil insulation type	Body, Shading coil material	Support material (in valve assembly)
Standard ^{Note 2)}	NBR	B	Brass, Copper	Polyacetal
A	FKM			
B	EPDM			
C	PTFE			
D ^{Note 2)}	FKM	H	Stainless steel	Stainless steel
E	EPDM			
F ^{Note 1)}	FKM	B	Stainless steel, Silver	Polyacetal
G	NBR			
H	FKM			
J	EPDM			
K ^{Note 1)}	PTFE			
L ^{Note 1)}	FKM			
M ^{Note 1)} (Non-leak)	FKM			
N	FKM			
P	EPDM	H	Stainless steel	Stainless steel
Q	PTFE(FKM)			
S	PTFE(FKM)	B	Brass, Copper	Polyacetal
T ^{Note 1)}	NBR			
V ^{Note 1)} (Non-leak)	FKM			
X ^{Note 1)}	FKM			



Note 1) Non-lube type. For other options, "-X21" at the end of product number represents the non-lube option.

Note 2) Grease has been applied to the core part.

Fluid Name and Option

Fluid (Application)	Option symbol and body material	
	Brass or BC6	Stainless steel
Caustic soda (25% ≥)	—	J
Gas oil	A	H
Silicon oil	A	H
Vacuum system (for pad)	Standard	—
Vacuum (up to 1.3 x 10 ⁻¹ Pa)	V ^{Note 1)}	M ^{Note 1)}
Fuel oil (up to 60°C)	A	H
Steam system (Boiler water)	—	G, J
Steam system (Steam)	S	Q
Steam system (Condensate)	E	P
Trichloroethylene	—	K
Trichloroethane	—	K
Parachloroethylene	A	H
Brake oil	B	J
Helium	V ^{Note 1)}	M ^{Note 1)}
Non-leak (10 ⁻⁶ Pa·m ³ /s)	V ^{Note 1)}	M ^{Note 1)}
Water (High temperature)	E, X	N, P



* If using for other fluids, please contact SMC.

Note 1) The leakage amount (10⁻⁶ Pa·m³/s) is value when differential pressure is 0.1 MPa.

Manifold Series VVX31/32/33

Normally Closed (N.C.), Normally Open (N.O.), Common (C.O.)



Refer to our catalog ES70-26A for specifications and models.

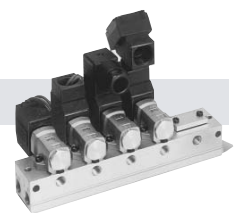

Option Symbol and Composition

Option symbol	Seal material	Coil insulation type	Body, Shading coil material	Support material (in valve assembly)
Standard ^{Note 2)}	NBR	B	Aluminum, Copper	Polyacetal
A	FKM			
B	EPDM			
D ^{Note 2)}	FKM			
E	EPDM	H	Stainless steel	Stainless steel
F ^{Note 1)}	FKM			
R ^{Note 1)} (Non-leak)	FKM	B	Brass, Silver ^{Note 3)}	Polyacetal
T ^{Note 1)}	NBR		Aluminum, Copper	
V ^{Note 1)} (Non-leak)	FKM		Brass, Copper ^{Note 3)}	
X ^{Note 1)}	FKM	H	Aluminum, Copper	Stainless steel



Note 1) Non-lube type. For other options, "-X21" at the end of product number represents the non-lube option.

Note 2) Grease has been applied to the core part.

Note 3) Manifold base material: Aluminum.

Fluid Name and Option

Fluid (Application)	Option symbol
Gas oil	A
Silicon oil	A
Fuel oil (up to 60°C)	A
Vacuum (for pad)	Standard
Vacuum (up to 1.3 x 10 ⁻¹ Pa)	V ^{Note 1)}
Parachloroethylene	A
Brake oil	B
Helium	V ^{Note 1)}
Non-leak (10 ⁻⁶ Pa·m ³ /s)	V ^{Note 1)}



* If using for other fluids, please contact SMC.

Note 1) The leakage amount (10⁻⁶ Pa·m³/s) is value when differential pressure is 0.1 MPa.

Glossary

Pressure

1. Max. operating pressure differential

This pressure difference is the highest pressure difference allowable to operate (a difference between the pressures in the inlet side and the outlet side) in an open state and the closed state of valve. A case of 0 kgf/cm² in the outlet side results in the highest operating pressure.

2. Min. operating pressure differential

This pressure difference is the lowest pressure difference (a difference between the pressures in the inlet side and the outlet side) required to hold the main valve fully open.

3. Max. system pressure

This pressure is the limit of pressure that can be applied to pipe line. (Line pressure)
[The pressure difference in a solenoid valve must be maintained less than the highest operating pressure difference.]

4. Proof pressure

This is the pressure that can be withstood without deterioration of the performance when valve returns within the range of the operating pressure. (A value under a specified condition.)

Electricity

1. Apparent power (VA)

Volt-ampere is the product of voltage (V) and current (A). Power dissipation (W): For AC, $W = V/A \cos\theta$. For DC, $W = V/A$ (Note) $\cos\theta$ shows power factor.

2. Surge voltage

The surge voltage is a high voltage generated momentarily when cutting the power supply.

3. Hum sound

The hum sound is a noise generated through repeated adsorption and releasing on an armature adsorption surface.

For an AC solenoid, no shading coil releases the spring reaction because of the existence of a 0 point (twice per frequency) of the suction force.

Others

1. Material

NBR: Nitrile rubber

FKM: Fluoro rubber—Trade names: Vitron®, Dai-el®, etc.

EPDM: Ethylene propylene rubber

PTFE: Polytetrafluoroethylene resin—Trade names: Teflon®, Polyflon®, etc.

Polyacetal (POM)—Trade names: Duracon®, Derlin®, etc.

2. Oil preserve treatment

After assembly, valve is put through a parts washer to remove any oil used during assembly.

3. Symbol

The JIS symbol is (☞☞☞☞): this designates the valve to be normally closed.

However, in situations where the secondary pressure exceeds the primary side pressure, the resulting back pressure will cause back flow through the valve.

VC□

VDW

VQ

VX2

VX□

VX3

VXA

VN□

LVC

LVA

LVH

LVD

LVQ

LQ

LVN

TI/
TIL

PA

PAX

PB

Caution

Refer to page 17-6-3 for Safety Instructions and Solenoid Valve Precautions.

Solenoid Coil Assembly

How to Order

VX021 — 001 C B — 01

VX solenoid coil assembly

Application

Size part no.	Applicable series	
001	No.1 Solenoid	Series VX□21
002	No.2 Solenoid	Series VX□22
003	No.3 Solenoid	Series VX□23

Electrical entry

G	Grommet
C	Conduit
D	DIN terminal

Electrical option

Nil	None
S	With surge voltage suppressor
L	With indicator light
Z	With light/ surge voltage suppressor

Terminal box

Nil	None
T	With terminal box

Coil insulation type

B	Class B insulation
H*	Class H insulation

* DIN terminal or DC not available.

Rated voltage ⁽¹⁾

01	100 VAC 50/60 Hz
02	200 VAC 50/60 Hz
03	110 VAC 50/60 Hz
04	220 VAC 50/60 Hz
05	24 VDC
06	12 VDC
07	240 VAC 50/60 Hz
08	48 VAC 50/60 Hz
13	24 VAC 50/60 Hz
23	440 VAC 50/60 Hz
51	6 VDC
53	48 VDC
55	100 VDC
56	110 VDC

Note 1) The voltage codes of 01 to 08 when the suffix "0" is removed, are the same as the solenoid valve model codes.

Ordering example

- Ex.) Series VX21, 100 VAC, Class B insulation, Grommet
 Part no.: "VX021-001GB-01"
 Ex.) Series VX22, 220 VAC, Class B insulation, DIN terminal with terminal box
 Part no.: "VX021-002DBT-04"
 Ex.) Series VX23, 24 VDC, Conduit terminal, with light/surge voltage suppressor
 Part no.: "VX021-003BTZ-05"

Coil Combination

("Electrical Entry"- "Coil Insulation"- "Electrical Option")

Electrical entry	Without electrical option	With electrical option		
		With surge voltage suppressor	With indicator light	With light/ surge voltage suppressor
Grommet	GB	GBS	—	—
	GH	—	—	—
Conduit	CB	—	—	—
	CH	—	—	—
	CBT	CBTS	CBTL	CBTZ
	CHT	CHTS	CHTL	CHTZ
DIN terminal	DB	—	—	—
	DBT	DBTS	DBTL	DBTZ

- * Applicable voltages with light/surge voltage suppressor are as follows;
 100 VAC, 200 VAC, 110 VAC, 220 VAC and 24 VDC.
 * Applicable voltages for "CHTL" and "CHTZ" are as follows; 100 VAC,
 200 VAC, 110 VAC, 220 VAC.

Made to Order Specifications

Splashproof Specifications (Based on JIS C 0920 Based on IEC529IP-X4)

Suffix "-X36" to the end of solenoid coil part number.

Direct Operated 3 Port Solenoid Valve/Manifold For Air, Gas, Vacuum and Oil

Series VVX31/32/33



■ **N.C./N.O. switchover is easy.**

(VX31C.O. type, VX32, VX33)

■ **A wide variety of applicable fluids.**

Combination of seal materials (NBR, FKM, or EPDM) can be selected freely, depending on the purpose.

■ **Able to replace valves with the piping remained unchanged.**

■ **Weight-saving aluminum base and body.**

(Not applicable to water or steam.)

VC□

VDW

VQ

VX2

VX□

VX3

VXA

VN□

LVC

LVA

L VH

LVD

L VQ

LQ

LVN

TI/
TIL

PA

PAX

PB

Variations

Valve ●

Normally Closed (N.C.) Normally Open (N.O.) Common (C.O.)

Port A

Port P

Port R

Normally closed (N.C.)

Normally open (N.O.)

Electrical entry

- Grommet
- Conduit
- DIN terminal
- Conduit terminal

Material

Body — Aluminum

Seal — NBR, FKM, EPDM

Rated voltage ●

AC

Standard — 100 V, 200 V

Option — 48 V, 110 V, 220 V, 240 V

DC

Standard — 24 V

Option — 12 V

Manifold ●

Manifold — B mount

Seal — 2 to 10 stations

Model

Model	Port A	Port P	Port R
VVX311-stations	1/8	1/4	1/4
VVX312-stations	1/4		
VVX321-stations	1/8		
VVX322-stations	1/4		
VVX331-stations	1/8		
VVX332-stations	1/4		

Series VVX31/32/33

The models VX31/32/33 have been revised. For details, please refer to catalog no. ES70-26A. Similar updating for other VX* series are scheduled to follow shortly.

Normally Closed (N.C.), Normally Open (N.O.), Common (C.O.)

JIS Symbol

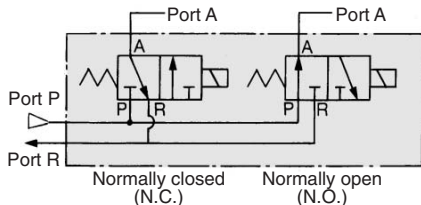

Solenoid Specifications

Model	Power source	Frequency (Hz)	Apparent power (VA)		Power consumption (W) (Holding)	Temperature rise (°C) (Rated voltage)
			Inrush	Holding		
VX31	AC	50	20	11	5	50
		60	17	7	3.5	45
	AC (Full wave rectification)	50/60	-	7.5	6	55
VX32	AC	50	42	18	7.5	55
		60	37	12	6	45
	AC (Full wave rectification)	50/60	-	10	8.5	60
VX33	AC	50	55	22	11	60
		60	47	18	9.5	50
	AC (Full wave rectification)	50/60	-	14	11.5	60
	DC	-	-	-	11.5	60

- Note • They are values in an ambient temperature of 20°C ± 5°C and application of rated voltage.
- AC coil for air (-X44) comes with full wave rectifier.
 - Changing coils from AC to DC and vice versa is impossible, because of different core shapes.
 - Return voltage is 20% or more of the rated value at AC power and 5% or more at the DC power.
 - Allowable voltage fluctuation is ± 10% of the rated voltage.

Operating Fluid and Ambient Temperature

Temp. conditions	Power source	Operating fluid temperature (°C)					Ambient temp. (°C)
		Water (Std.)	Oil (Std.)	High temp. water (X, E, N, P)	Oil (D, N)	Steam (S, Q)	
Maximum	AC	60	60	99	120	183	60
	DC	40	40	-	-	-	40
Minimum	AC, DC	1	-5	-	-	-	-20

Temp. conditions	Power source	Operating fluid temp. (°C)		Ambient temperature (°C)
		Air	Vacuum	
Maximum	AC/DC	60	40	40
Minimum	AC/DC	-10	-10	-20

Tightness of Valve (Leak rate)

Seal material	Fluid			Non-leak ⁽²⁾ Vacuum
	Air	Liquid		
NBR, FKM, EPDM	1 cm ³ /min or less	0.1 cm ³ /min or less ⁽¹⁾		10 ⁻⁶ Pa·m ³ /s or less

- Note 1) Differs depending on the operating conditions such as pressure, etc.
 Note 2) Value on option "V", "R", "Y" (Non-leak, Vacuum).

Manifold Specifications

Manifold	B Mount	
Manifold type	Common supply, Common exhaust, Individual out	
Number of valves	2 to 10 stations	
Blanking plate (with gasket, screws)	VVX31	VX011-004
	VVX32/33	VX011-005

Manifold Base and Applicable Solenoid Valve Part No.

Manifold base	A port	Applicable solenoid valve	Base weight (g)
VVX311-stations	Rc 1/8	VX31□ $\frac{1}{8}$ -00-□□	n x 100 + 50
VVX312-stations	Rc 1/4		
VVX321-stations	Rc 1/8	VX32□5-00-□□	n x 160 + 60
VVX322-stations	Rc 1/4		
VVX331-stations	Rc 1/8	VX33□5-00-□□	n x 160 + 60
VVX332-stations	Rc 1/4		

Model/Valve Specifications (Fluids: Oil)

Orifice size (mmø)	Model	Max. operating pressure differential (MPa)		Flow characteristics		Max. system pressure (MPa)	Weight (g)
		N.O., N.C.	C.O.	Oil			
				Av x 10 ⁻⁶ (m ²)	Cv converted		
1.5	VX311 $\frac{1}{8}$ -00	1.0	0.6	1.9	0.08	1.0	220
	VX312 $\frac{1}{8}$ -00	0.5	0.3	3.8	0.16		220
2.2	VX3225-00	-	0.6	4.6	0.19	1.0	370
	VX3325-00	-	1.0				530
	VX313 $\frac{1}{8}$ -00	0.3	0.2	5.8	0.24		220
3	VX3235-00	-	0.3	7.9	0.33	1.0	370
	VX3335-00	-	0.6				530
	VX3245-00	-	0.15	12	0.5		1.0
VX3345-00	-	0.3	530				

Model/Valve Specifications (Fluids: Air, Vacuum, Inert gas)

Orifice size (mmø)	Model	Max. operating pressure differential (MPa)		Flow characteristics			Max. system pressure (MPa)	Weight (g)
		C.O.	AC/DC	Air				
				C [dm ³ /(s·bar)]	b	Cv		
1.5	VX3115-00	0.6		0.29	0.32	0.08	1.0	220
	VX3125-00	0.3		0.60	0.25	0.15		220
2.2	VX3225-00	0.6		0.64	0.40	0.17	1.0	370
	VX3325-00	1.0						530
	VX3135-00	0.2		0.82	0.20	0.20		220
3	VX3235-00	0.3		1.1	0.25	0.27	1.0	370
	VX3335-00	0.6						530
	VX3245-00	0.15		1.6	0.20	0.38		1.0
VX3345-00	0.3		530					

Response Characteristics

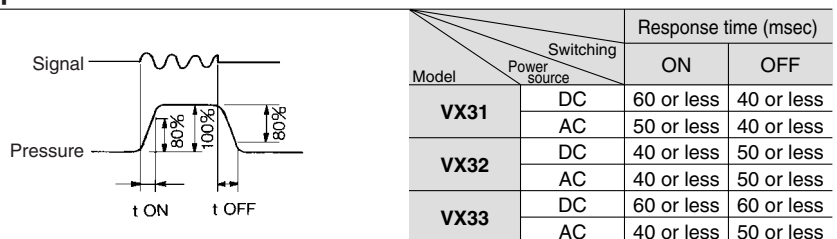

- Note) The value is the case of no grease applied on armature.

Direct Operated 3 Port Solenoid Valve/Manifold Series VVX31/32/33

For Air, Gas, Vacuum and Oil

The models VX31/32/33 have been revised. For details, please refer to catalog no. ES70-26A. Similar updating for other VX series are scheduled to follow shortly.

How to Order Solenoid Valves for Manifold

[For liquid and gas (DC voltage)]

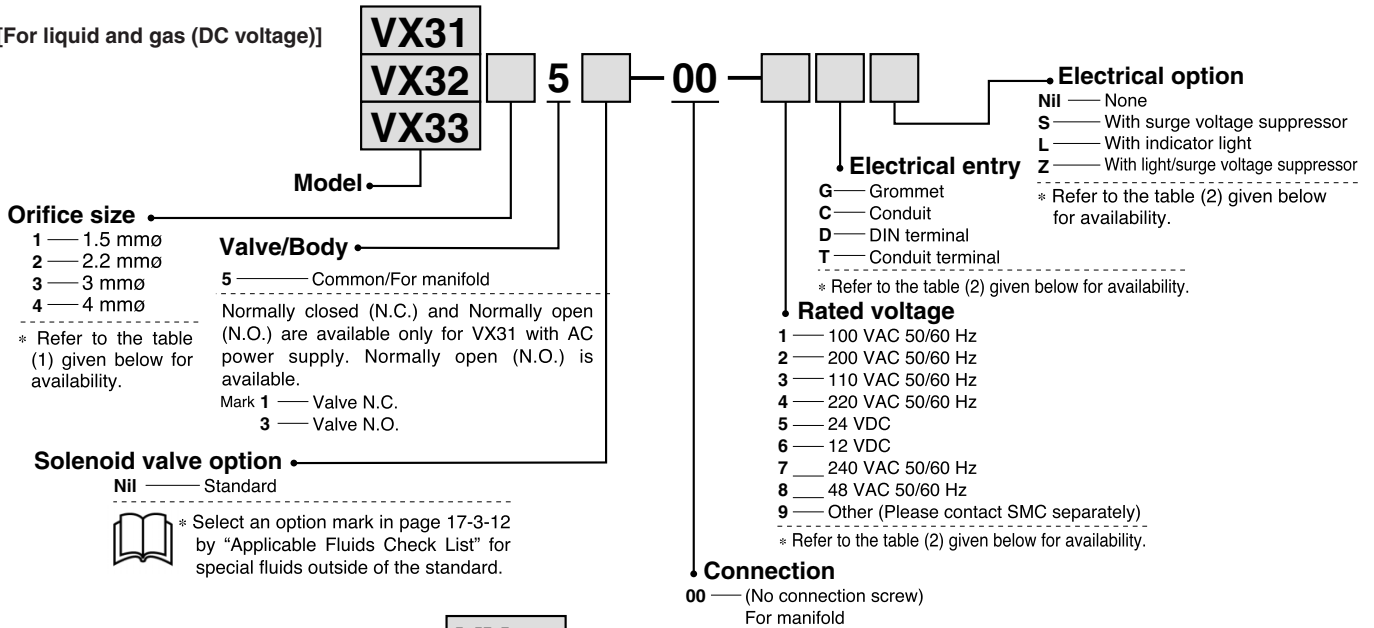

[For gas (AC voltage)]

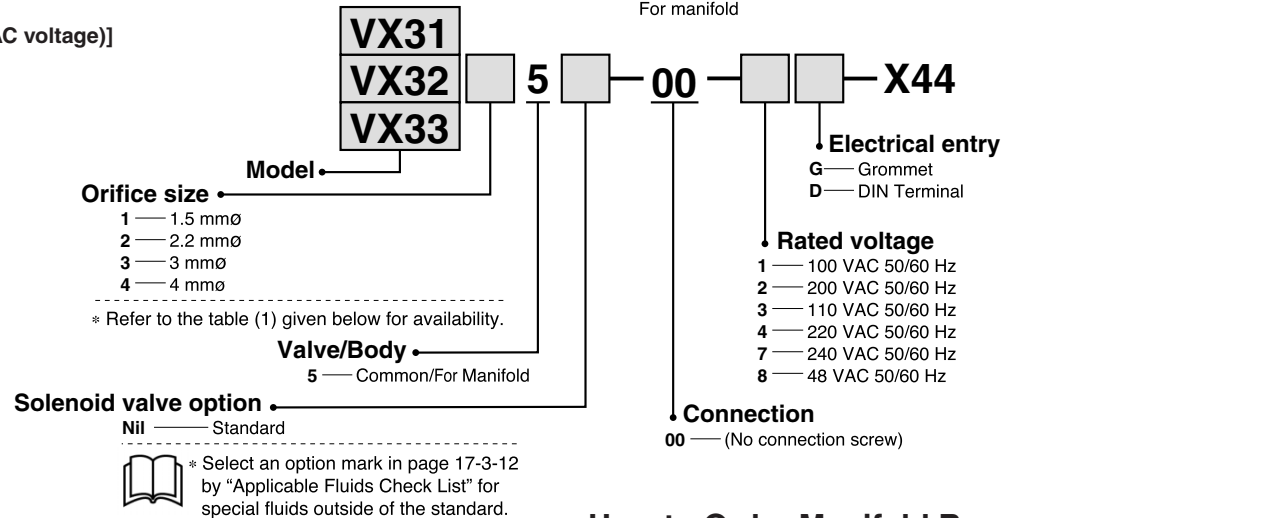

How to Order Manifold Base

Table (1) Orifice Size

Solenoid valve model	Orifice size (No.)			
	1 (1.5 mm ϕ)	2 (2.2 mm ϕ)	3 (3 mm ϕ)	4 (4 mm ϕ)
VX31	●	●	●	—
VX32	—	●	●	●
VX33	—	●	●	●

Table Electrical (2) Rated Voltage-Electrical Entry-Electrical Option

Insulation type	Class B				Class H		
	G	C	D, T	G, C	T		
Electrical option	S ^{Note}	—	S, L, Z	—	S, L, Z		
AC	1 (100 V)	●	●	●	●	●	●
	2 (200 V)	●	●	●	●	●	●
	3 (110 V)	●	●	●	●	●	●
	4 (220 V)	●	●	●	●	●	●
DC	7 (240 V)	●	●	—	●	—	—
	8 (48 V)	●	●	—	—	●	—
	5 (24 V)	●	●	—	—	—	—
	6 (12 V)	●	●	—	—	—	—

Note) Surge voltage suppressor is attached in the middle of lead wire.

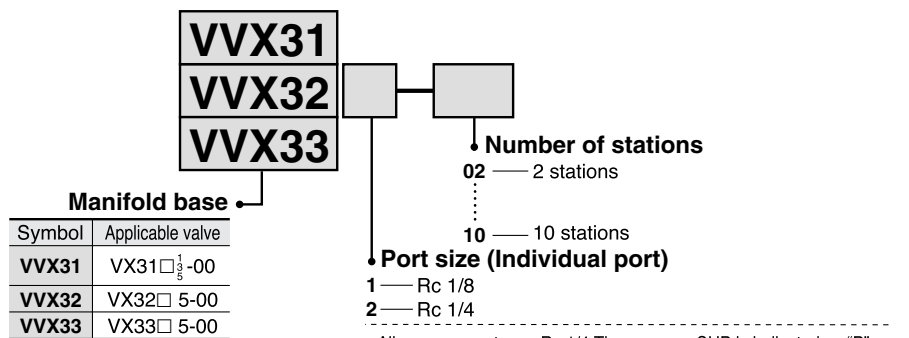

How to Order Manifold

Write both the base part number and the solenoid valve to be mounted or blanking plate part number.

(Example) 7 stations of VX31 common SUP, individual port Rc 1/8.

(Base P/N) VVX311-07..... 1 pc.
 (Solenoid valve P/N) VX3111-00-1G.....6 pcs.
 (Blanking plate P/N) VX011-004..... 1 pc.

Arrangement of solenoid

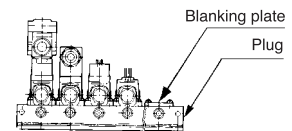

The standard arrangements of manifolds should be placed on an individual port on this side, each solenoid valve from the left side and a blank plate in the right side. The right side of the common port provides plug.

VC □

VDW

VQ

VX2

VX □

VX3

VXA

VN □

LVC

LVA

LVH

LVD

LVQ

LQ

LVN

TI/
TIL

PA

PAX

PB

Series VVX31/32/33

The models VX31/32/33 have been revised. For details, please refer to catalog no. ES70-26A. Similar updating for other VX* series are scheduled to follow shortly.

Construction/Principal Parts Material

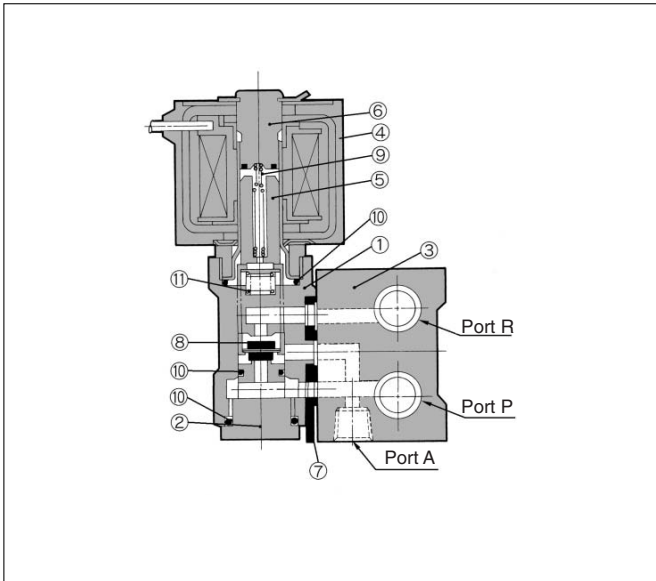

No.	Description	Material	
		Standard	Option
①	Manifold body	Aluminum	Brass
②	Retainer	Aluminum	Brass
③	Manifold base	Aluminum	—
④	Coil assembly	Class B molded	Class H molded
⑤	Armature	Stainless steel	—
⑥	Core assembly	Stainless steel, Copper	Stainless steel, Silver
⑦	Gasket	NBR	FKM/EPDM
⑧	Valve assembly	Polyacetal, NBR	Stainless steel FKM/EPDM
⑨	Return spring	Stainless steel	—
⑩	O-ring	NBR	FKM/EPDM
⑪	Support spring	Stainless steel	—

Direct Operated 3 Port Solenoid Valve/Manifold For Air, Gas, Vacuum and Oil Series **VVX31/32/33**

The models VX31/32/33 have been revised. For details, please refer to catalog no. ES70-26A. Similar updating for other VX* series are scheduled to follow shortly.

Dimensions

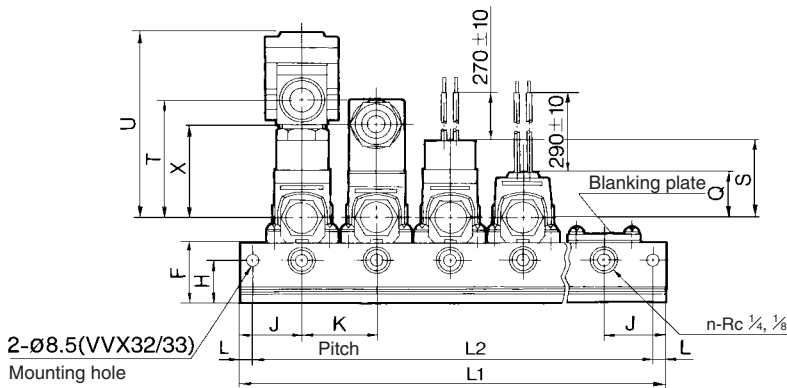
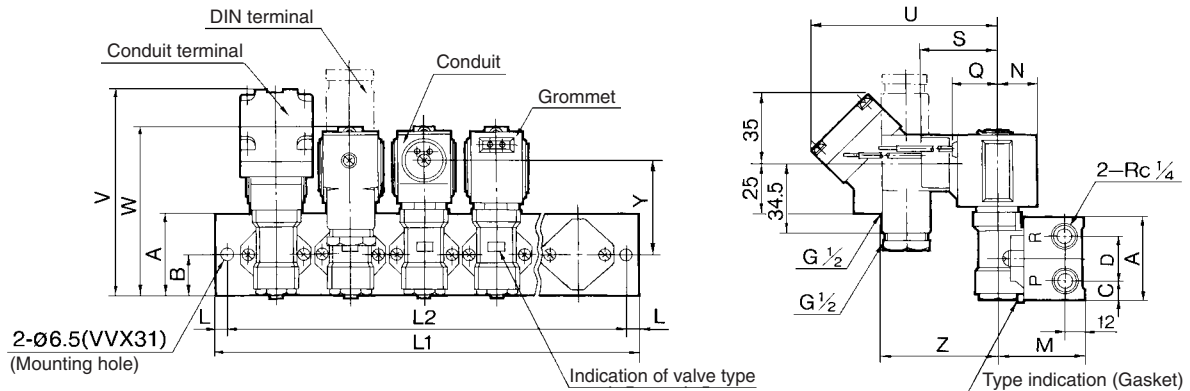

Model	Symbol	Stations									
		2	3	4	5	6	7	8	9	10	
VVX31	L ₁	96	132	168	204	240	276	312	348	384	
	L ₂	84	120	156	192	228	264	300	336	372	
VVX32	L ₁	126	172	218	264	310	356	402	448	494	
VVX33	L ₂	108	154	200	246	292	338	384	430	476	

Model	A	B	C	D	F	H	J	K	L	M	N	Q	S	T	U	V	W	X	Y	Z
VVX31	40	20	9	22	33	24	30	36	6	45.5	20	23	39	59	92	102	83	47	47	59
VVX32	44	22	10	24	34	25	40	46	9	50.5	23	25	41	62	95	114	99	48	58	62
VVX33	44	22	10	24	34	25	40	46	9	50.5	25.5	28	44	64	97	123	106	51	67	64

- VC
- VDW
- VQ
- VX2
- VX
- VX3**
- VXA
- VN
- LVC
- LVA
- LVH
- LVD
- LVQ
- LQ
- LVN
- TI/TIL
- PA
- PAX
- PB