

Aluminum

High Vacuum Angle Valve

RoHS



Aluminum bodied

- Uniform baking temperature
- Lightweight, Compact
- Minimal outgassing
- Minimal contamination from heavy metals
- High corrosion resistance to fluorine gas

Bellows are replaceable

(Bellows seal type)

The bellows assembly can be replaced, which reduces maintenance costs and waste materials.

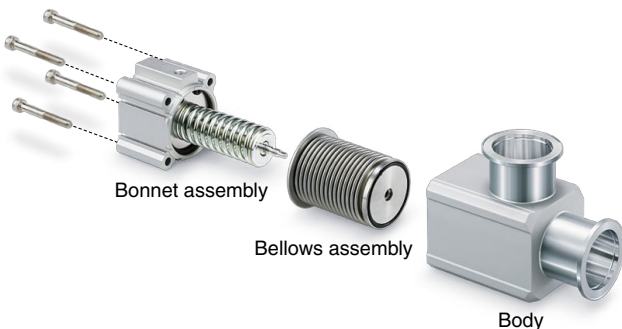

XL□ Series

New

A model with a solenoid valve has been added.



New

A heat-resistant 2-color indicator solid state auto switch has been added to the high-temperature type. (Made to order on page 18)

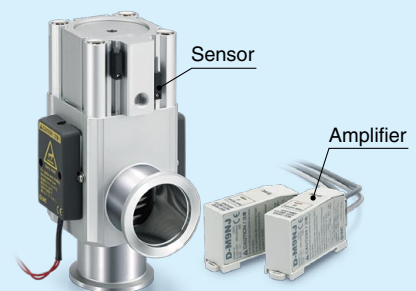

SMC

CAT.ES140-8C

Uniform baking temperature

Excellent thermal conductivity results in a uniform temperature for the entire valve body and a marked decrease in the condensation of gases inside the valve.

Comparison with a KF25 flange

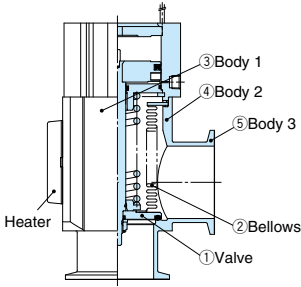

Temperature distribution of the 120°C specification

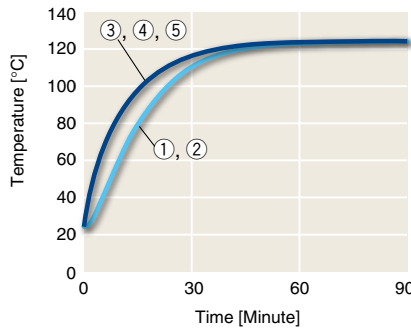

Lightweight, Compact

Large conductance, small body, excellent resistance against fluorine corrosion (body)

XLA series

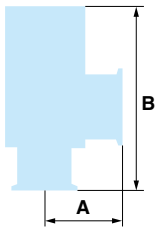

Model	A*1 [mm]	B [mm]	Weight [kg]	Conductance*1 [L/s]
XLA-16-2	40	108	0.28	5
XLA-25-2	50	121	0.47	14
XLA-40-2	65	171	1.1	45
XLA-50-2	70	185	1.8	80
XLA-63-2	88	212	3.1	160
XLA-80-2	90	257	5.1	200

*1 The same for all series

Minimal outgassing

Low outgassing makes it possible to use a lower capacity pump and also shorten exhaust time.

Minimal contamination from heavy metals

The valve does not contain heavy metals such as Ni (nickel) or Cr (chrome) and it's low sputtering yield also helps to minimize the heavy metal contamination of semiconductor wafers.

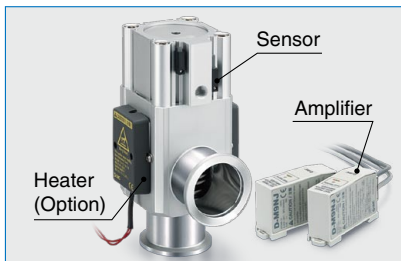

New

A heat-resistant 2-color indicator solid state auto switch is available for models with a heater. (Option)

- Ambient temperature: Max. 150°C (Sensor)
- 2-color indicator



An optional heater is available. For 100/120°C

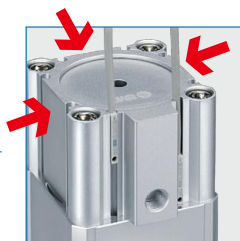

Auto switches are mountable from 4 directions.



High Vacuum Angle Valve **XL**-2 Series New Variations

Type	Series	Valve type	Shaft seal type	Application	Flange size										
					16	25	40	50	63	80	100		160		
Air operated	XLA-2	Single acting (N.C.)	Bellows seal	Dust free, cleaned	★	★	★	★	★	★					P.3
	New XLAV-2 (With solenoid valve)	Single acting (N.C.)	Bellows seal	Dust free, cleaned	★	★	★	★	★	★					P.4
	XLC-2	Double acting	Bellows seal	Dust free, cleaned	★	★	★	★	★	★					P.7
	XLF-2	Single acting (N.C.)	O-ring seal	High-speed operation High operating cycles	★	★	★	★	★	★					P.10
	New XLFV-2 (With solenoid valve)	Single acting (N.C.)	O-ring seal	High-speed operation High operating cycles	★	★	★	★	★	★					P.11
	XLG-2	Double acting	O-ring seal	High-speed operation High operating cycles	★	★	★	★	★	★					P.14

* The XLCV and XLGV series are available as made to order. Please contact SMC for details.

High Vacuum Angle Valve Series Variations

Type	Series	Valve type	Shaft seal type	Application	Flange size									
					16	25	40	50	63	80	100		160	
Air operated	XLA	Single acting (N.C.)	Bellows seal	Dust free, cleaned	★	★	★	★	★	★	●	●		
	XLAV (With solenoid valve)	Single acting (N.C.)	Bellows seal	Dust free, cleaned	★	★	★	★	★	★	●	●		
	XLC	Double acting	Bellows seal	Dust free, cleaned	★	★	★	★	★	★				
	XLCV (With solenoid valve)	Double acting	Bellows seal	Dust free, cleaned	●	●	●	●	●	●				
	XLF	Single acting (N.C.)	O-ring seal	High-speed operation High operating cycles	★	★	★	★	★	★	●	●		
	XLFV (With solenoid valve)	Single acting (N.C.)	O-ring seal	High-speed operation High operating cycles	★	★	★	★	★	★	●	●		
	XLG	Double acting	O-ring seal	High-speed operation High operating cycles	★	★	★	★	★	★	●	●		
	XLGV (With solenoid valve)	Double acting	O-ring seal	High-speed operation High operating cycles	●	●	●	●	●	●				
	XLD	Single acting (N.C.)	Bellows seal O-ring seal	For preventing dust turbulence	●	●	●	●	●	●	●	●		
	XLDV (With solenoid valve)			For preventing a pump from running overloaded	●	●	●	●	●	●	●	●	●	
Manual	XLH	Manual	Bellows seal	Dust free, cleaned	●	●	●	●						
Electromagnetic	XLS	Single acting (N.C.)	(Bellows balance)	For portable equipment not requiring air	●	●								

Sizes marked with a ★ have been remodeled. Select the series shown above.

★ mark:



● mark: Refer to the Web Catalog.



Aluminum High Vacuum Angle Valve Normally Closed, Bellows Seal **XLA/XLAV Series**



XLA

How to Order

XLA - **16** **□** **□** **□** - **2** **M9N** **A** - **□**

① ② ③ ④ ⑤ ⑥ ⑦

① Flange size

Size
16
25
40
50
63
80

② Flange type

Symbol	Type	Applicable flange size
Nil	KF (NW)	16, 25, 40, 50, 63, 80
D	K (DN)	63, 80

③ Indicator/Pilot port direction

Symbol	Indicator	Pilot port direction
Nil	Without indicator	Flange side
A	With indicator	Flange side
F		Left flange surface
G		Rear flange surface
J		Right flange surface
K	Without indicator	Left flange surface
L		Rear flange surface
M		Right flange surface

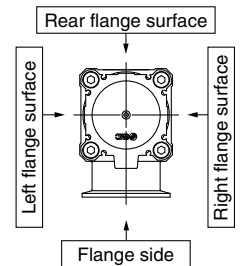

④ Temperature specifications/Heater

Symbol	Temperature	Heater	
Nil	5 to 60°C	—	
High-temperature type	H0	—	
	H4	5 to 150°C	With 100°C heater
	H5	—	With 120°C heater

* Size 16 is not applicable to H4, H5. Size 25 is not applicable to H4.
* Heater cannot be retrofitted for the H0 type.

⑤ Auto switch type

Symbol	Model	Remarks
Nil	—	Without auto switch (without magnet)
M9N(M)(L)(Z)	D-M9N(M)(L)(Z)	Solid state auto switch
M9P(M)(L)(Z)	D-M9P(M)(L)(Z)	
M9B(M)(L)(Z)	D-M9B(M)(L)(Z)	
A90(L)	D-A90(L)	Reed auto switch (Not applicable to flange size 16)
A93(M)(L)(Z)	D-A93(M)(L)(Z)	—
M9//	—	Without auto switch (with magnet)

* For the high-temperature type, select the heat-resistant auto switch. (Refer to page 18.)
* Standard lead wire length is 0.5 m. Add M to the end of the part number for 1 m, L for 3 m, and Z for 5 m.
Example) -2M9NL

⑥ Number of auto switches/Mounting position

Symbol	Quantity	Mounting position
Nil	Without auto switch	—
A	2	Valve open/closed
B	1	Valve open
C	1	Valve closed

⑦ Body surface treatment/Seal material and changed parts

• Body surface treatment

Symbol	Surface treatment
Nil	External: Hard anodized Internal: Raw material
A	External: Hard anodized Internal: Oxalic acid anodized

• Seal material

Symbol	Seal material	Compound no.
Nil	FKM	1349-80*1
N1	EPDM	2101-80*1
P1	Barrel Perfluoro®	70W
Q1	Kalrez®	4079
R1	Chemraz®	SS592
R2		SS630
R3		SSE38
S1	VMQ	1232-70*1
T1	FKM for Plasma	3310-75*1

*1 Produced by Mitsubishi Cable Industries, Ltd.

• Part with changed seal material and leakage

Symbol	Changed part *2	Leakage [Pa · m ³ /s or less] *1	
		Internal	External
Nil	None	1.3 x 10 ⁻¹⁰ (FKM)	1.3 x 10 ⁻¹¹ (FKM)
A	②, ③, ④	1.3 x 10 ⁻⁸	1.3 x 10 ⁻⁹
B	②, ③	1.3 x 10 ⁻⁸	1.3 x 10 ⁻⁹
C	④	1.3 x 10 ⁻¹⁰ (FKM)	1.3 x 10 ⁻⁹
D	②	1.3 x 10 ⁻⁸	1.3 x 10 ⁻¹¹ (FKM)
E	②, ④	1.3 x 10 ⁻⁸	1.3 x 10 ⁻⁹

*1 Values at normal temperature, excluding gas permeation
*2 Refer to Construction on page 5 for changed part. Number corresponds with the parts number on the construction drawing.

To order something other than Nil (standard), list the symbols starting with X, followed by each symbol for body surface treatment, seal material, and then changed part.

Example) XLA-16-2M9NA-XAN1A

Barrel Perfluoro® is a registered trademark of Matsumura Oil Co., Ltd.
Kalrez® is a registered trademark of E. I. du Pont de Nemours and Company or its affiliates.
Chemraz® is a registered trademark of Greene, Tweed Technologies, Inc.

Air Operated, With Solenoid Valve

Solenoid valve

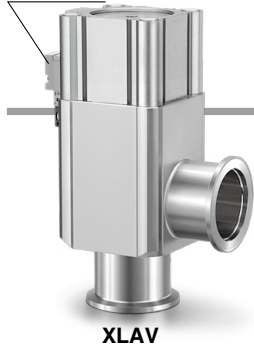

XLAV

How to Order

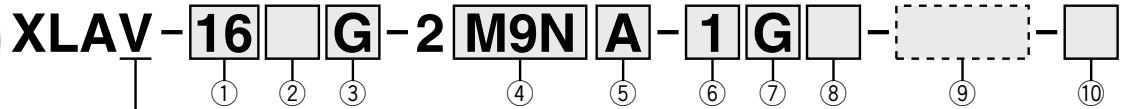

• Air operated, With solenoid valve

① Flange size

Size
16
25
40
50
63
80

② Flange type

Symbol	Type	Applicable flange size
Nil	KF (NW)	16, 25, 40, 50, 63, 80
D	K (DN)	63, 80

③ Indicator/Solenoid valve direction

Symbol	Indicator	Solenoid valve direction
F	With indicator	Left flange surface
G		Rear flange surface
J		Right flange surface
K	Without indicator	Left flange surface
L		Rear flange surface
M		Right flange surface

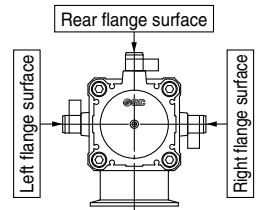

* M type plug connector (AC power supply) not attached for J, M of sizes 16 and 25.

④ Auto switch type

Symbol	Model	Remarks
Nil	—	Without auto switch (without magnet)
M9N(M)(L)(Z)	D-M9N(M)(L)(Z)	Solid state auto switch
M9P(M)(L)(Z)	D-M9P(M)(L)(Z)	
M9B(M)(L)(Z)	D-M9B(M)(L)(Z)	
A90(L)	D-A90(L)	Reed auto switch (Not applicable to flange size 16)
A93(M)(L)(Z)	D-A93(M)(L)(Z)	
M9//	—	Without auto switch (with magnet)

* Standard lead wire length is 0.5 m. Add M to the end of the part number for 1 m, L for 3 m, and Z for 5 m.

Example) -2M9NL

⑤ Number of auto switches/Mounting position

Symbol	Quantity	Mounting position
Nil	Without auto switch	—
A	2	Valve open/closed
B	1	Valve open
C	1	Valve closed

⑥ Rated voltage

		CE-compliant
1	100 VAC, 50/60 Hz	—
2	200 VAC, 50/60 Hz	—
3	110 VAC, 50/60 Hz	—
4	220 VAC, 50/60 Hz	—
5	24 VDC	○
6	12 VDC	○

⑦ Electrical entry

G	Grommet (Lead wire length 300 mm)
H	Grommet (Lead wire length 600 mm)
L	L type plug connector
M	M type plug connector

⑧ Light/surge voltage suppressor

Nil	None
S	With surge voltage suppressor
Z	With light/surge voltage suppressor
U	With light/surge voltage suppressor (Non-polar type)

* S type: Not available for AC
* U type: DC only

⑩ CE-compliant

Nil	—
Q	CE-compliant

⑨ Body surface treatment/Seal material and changed parts

• Body surface treatment

Symbol	Surface treatment
Nil	External: Hard anodized Internal: Raw material
A	External: Hard anodized Internal: Oxalic acid anodized

• Seal material

Symbol	Seal material	Compound no.
Nil	FKM	1349-80*1
N1	EPDM	2101-80*1
P1	Barrel Perfluoro®	70W
Q1	Kalrez®	4079
R1	Chemraz®	SS592
R2		SS630
R3		SSE38
S1	VMQ	1232-70*1
T1	FKM for Plasma	3310-75*1

*1 Produced by Mitsubishi Cable Industries, Ltd.

• Part with changed seal material and leakage

Symbol	Changed part *2	Leakage [Pa · m ³ /s or less] *1	
		Internal	External
Nil	None	1.3 x 10 ⁻¹⁰ (FKM)	1.3 x 10 ⁻¹¹ (FKM)
A	②, ③, ④	1.3 x 10 ⁻⁸	1.3 x 10 ⁻⁹
B	②, ③	1.3 x 10 ⁻⁸	1.3 x 10 ⁻⁹
C	④	1.3 x 10 ⁻¹⁰ (FKM)	1.3 x 10 ⁻⁹
D	②	1.3 x 10 ⁻⁸	1.3 x 10 ⁻¹¹ (FKM)
E	②, ④	1.3 x 10 ⁻⁸	1.3 x 10 ⁻⁹

*1 Values at normal temperature, excluding gas permeation

*2 Refer to Construction on page 5 for changed part. Number corresponds with the parts number on the construction drawing.

To order something other than Nil (standard), list the symbols starting with X, followed by each symbol for body surface treatment, seal material, and then changed part.

Example) XLAV-16L-2M9NA-1G-XAN1A

* With solenoid valve: Option specifications/Combinations

This model has indicator, auto switch, and K (DN) flange options, but high-temperature/heater options are not available.

* Solenoid valves

XLAV-16, 25, 40, 50: SYJ319, XLAV-63, 80: SYJ519

Example) SYJ319-1GS, etc.

For details, please contact your SMC sales representative.

** For option "Q," the solenoid valve should be a CE-compliant product.

Barrel Perfluoro® is a registered trademark of Matsumura Oil Co., Ltd.
Kalrez® is a registered trademark of E. I. du Pont de Nemours and Company or its affiliates.
Chemraz® is a registered trademark of Greene, Tweed Technologies, Inc.

XLA/XLAV Series

Specifications

Model	XLA(V)-16-2	XLA(V)-25-2	XLA(V)-40-2	XLA(V)-50-2	XLA(V)-63-2	XLA(V)-80-2	
Valve type	Normally closed (Pressurize to open, Spring seal)						
Fluid	Inert gas under vacuum						
Operating temperature [°C]	XLA	5 to 60 (High-temperature type: 5 to 150)					
	XLAV	5 to 50					
Operating pressure [Pa(abs)]	1 x 10 ⁻⁶ to atmospheric pressure						
Conductance [L/s]*1	5	14	45	80	160	200	
Leakage [Pa·m ³ /s]	Internal	For standard seal material (FKM): 1.3 x 10 ⁻¹⁰ at normal temperature, excluding gas permeation					
	External	For standard seal material (FKM): 1.3 x 10 ⁻¹¹ at normal temperature, excluding gas permeation					
Flange type	KF (NW)				KF (NW), K (DN)		
Principal materials	Body: Aluminum alloy, Bellows: Stainless steel 316L, Chief part: Stainless steel, FKM (Standard seal material)						
Surface treatment	External: Hard anodized Internal: Raw material						
Pilot pressure [MPa(G)]	0.4 to 0.7						
Pilot port size	XLA	M5		Rc1/8			
	XLAV	M5: Port 1(P), 3(R)			Rc1/8: Port 1(P), M5: Port 3(R)		
Weight [kg]	XLA	0.28	0.47	1.1	1.7	3.1	5.1
	XLAV	0.33	0.52	1.2	1.8	3.2	5.2

*1 Conductance is the value for the elbow with the same dimensions.

Construction/Operation

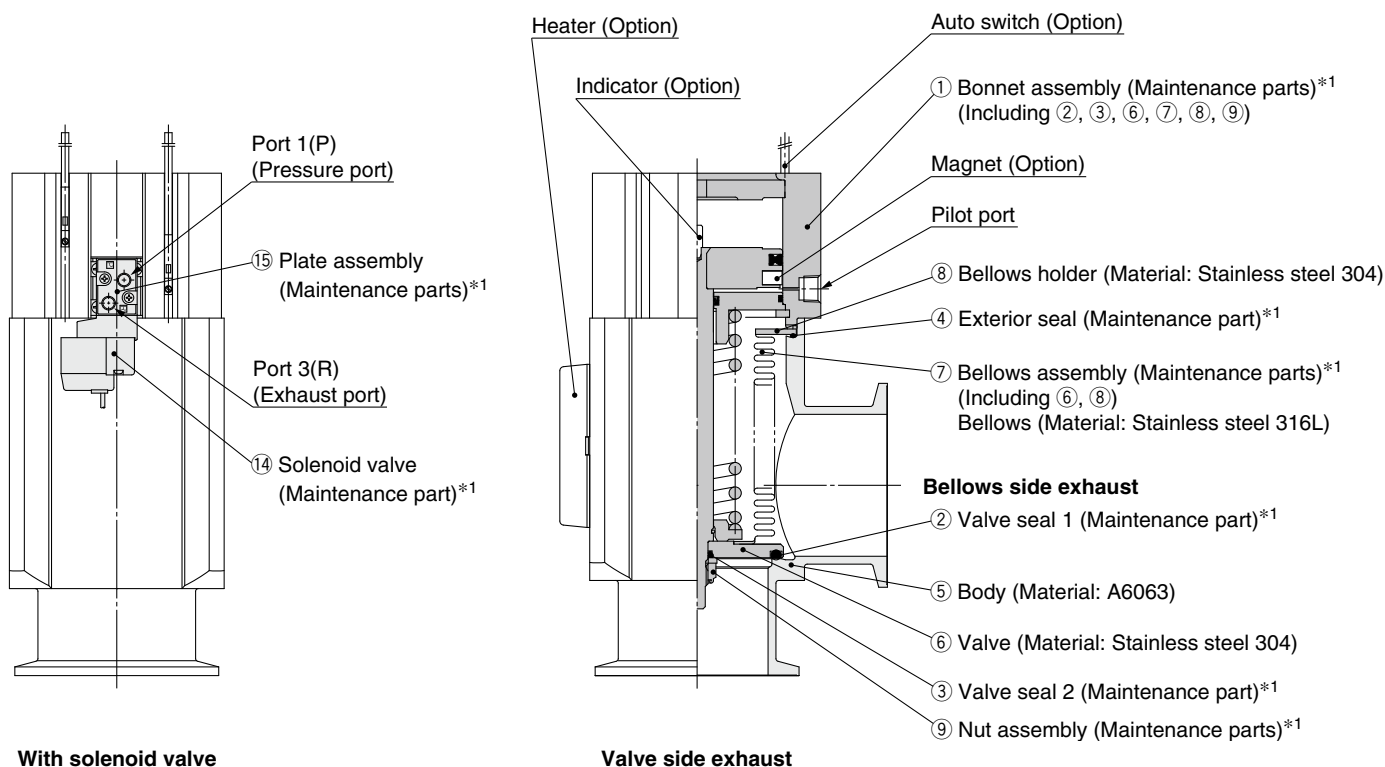

With solenoid valve

Valve side exhaust

*1 Refer to Maintenance Parts on page 24.

<Working principle>

By applying pilot pressure from the pilot port, the piston-coupled valve overcomes the force of the spring or operating force by pressure, and the valve opens.

In the case of the XLAV, port 1(P) is normally pressurized, and the valve opens when the solenoid valve is turned ON and closes when it is turned OFF.

5

<Option>

Auto switch: The magnet activates the auto switch. With 2 auto switches, the open and closed positions are detected, and with 1 auto switch, either the open or closed position is detected. The temperature range is only available for general use (5 to 60°C).

Heater: Heating is performed simply using thermistors. The valve body can be heated to approximately 100 or 120°C, depending on the size of the product. The type and number of thermistors to be used will vary depending on the size and setting temperature. For the high-temperature type, the bonnet assembly is a heat-resistant structure.

Indicator: When the valve is open, a marker appears in the center of the upper surface of the bonnet.

Dimensions

XLA: Air operated

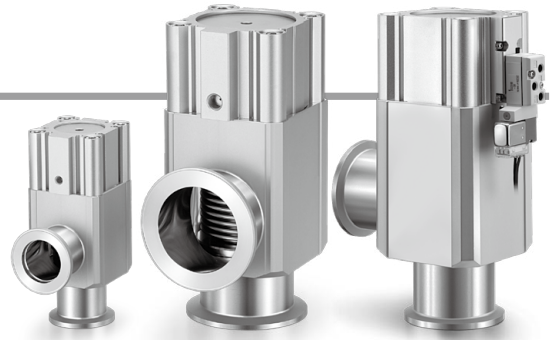
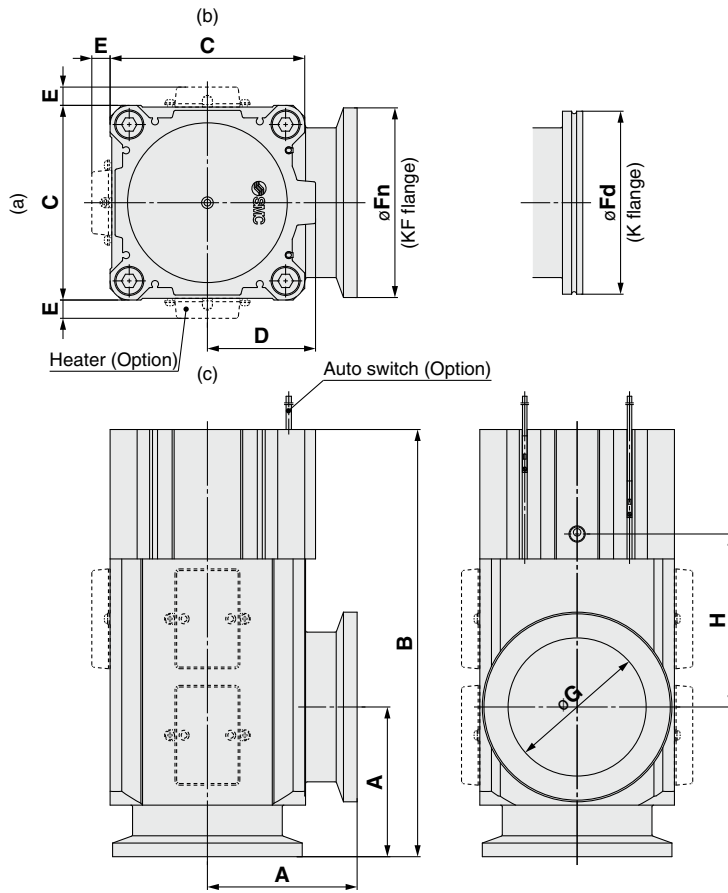

Model	A	B	C	D	E*1	F _n	F _d	G	H
XLA-16-2	40	108	38	20	—	30	—	17	44
XLA-25-2	50	121	48	27	12	40	—	26	44
XLA-40-2	65	171	66	39	11	55	—	41	67
XLA-50-2	70	185	79	46	11	75	—	52	72
XLA-63-2	88	212	100	55	11	87	95	70	76
XLA-80-2	90	257	117	65	11	114	110	83	104

*1 The E dimension applies when the heater option is included. (Lead wire length: Approx. 1 m)

* (a), (b), (c) in the above drawing indicate heater mounting positions. Moreover, heater mounting positions will differ depending on the type of heater.

For details, refer to Common Option [2] Mounting position of the heater on page 17.

XLAV: Air operated, With solenoid valve

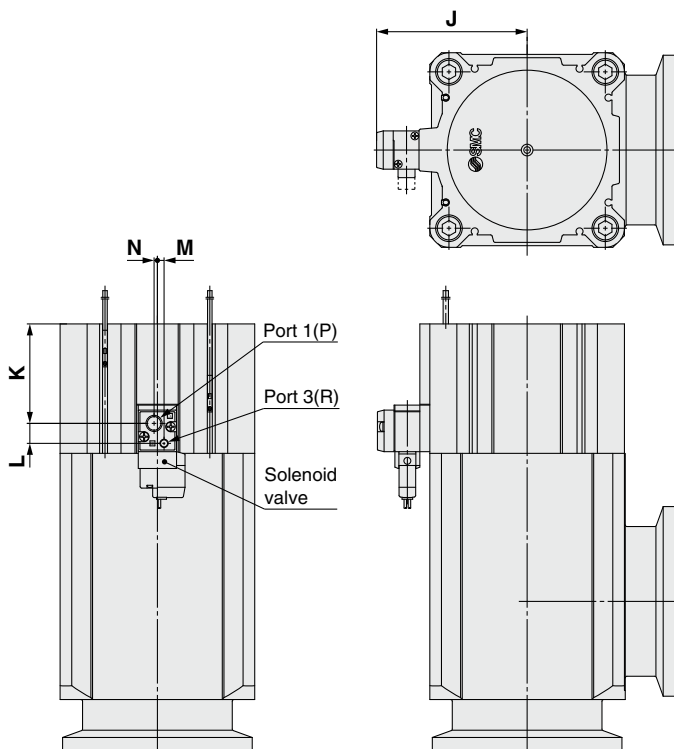

Model	J	K	L	M	N
XLAV-16-2	41	18.5	8.5	2.7	3
XLAV-25-2	45.5	22.5	8.5	2.7	3
XLAV-40-2	54.5	35	8.5	2.7	3
XLAV-50-2	61	39.5	8.5	2.7	3
XLAV-63-2	80.5	44	12	4	2
XLAV-80-2	90.5	60	12	4	2

Aluminum High Vacuum Angle Valve Double Acting, Bellows Seal **XLC Series**

RoHS



How to Order

XLC - **16** **□** **□** **□** - 2 **M9N** **A** - **□**

① ② ③ ④ ⑤ ⑥ ⑦

① Flange size

Size
16
25
40
50
63
80

② Flange type

Symbol	Type	Applicable flange size
Nil	KF (NW)	16, 25, 40, 50, 63, 80
D	K (DN)	63, 80

③ Pilot port direction

Symbol	Pilot port direction
Nil	Flange side
K	Left flange surface
L	Rear flange surface
M	Right flange surface

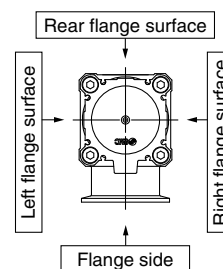

④ Temperature specifications/Heater

Symbol	Temperature	Heater
Nil	5 to 60°C	—
High-temperature type	H0	—
	H4	5 to 150°C With 100°C heater
	H5	5 to 150°C With 120°C heater

* Size 16 is not applicable to H4, H5. Size 25 is not applicable to H4.
* Heater cannot be retrofitted for the H0 type.

⑤ Auto switch type

Symbol	Model	Remarks
Nil	—	Without auto switch (without magnet)
M9N(M)(L)(Z)	D-M9N(M)(L)(Z)	Solid state auto switch
M9P(M)(L)(Z)	D-M9P(M)(L)(Z)	
M9B(M)(L)(Z)	D-M9B(M)(L)(Z)	
A90(L)	D-A90(L)	Reed auto switch (Not applicable to flange size 16)
A93(M)(L)(Z)	D-A93(M)(L)(Z)	—
M9//	—	Without auto switch (with magnet)

* For the high-temperature type, select the heat-resistant auto switch. (Refer to page 18.)
* Standard lead wire length is 0.5 m. Add M to the end of the part number for 1 m, L for 3 m, and Z for 5 m.
Example) -2M9NL

⑥ Number of auto switches/Mounting position

Symbol	Quantity	Mounting position
Nil	Without auto switch	—
A	2	Valve open/closed
B	1	Valve open
C	1	Valve closed

⑦ Body surface treatment/Seal material and changed parts

• Body surface treatment

Symbol	Surface treatment
Nil	External: Hard anodized Internal: Raw material
A	External: Hard anodized Internal: Oxalic acid anodized

• Seal material

Symbol	Seal material	Compound no.
Nil	FKM	1349-80*1
N1	EPDM	2101-80*1
P1	Barrel Perfluoro®	70W
Q1	Kalrez®	4079
R1	Chemraz®	SS592
R2		SS630
R3		SSE38
S1	VMQ	1232-70*1
T1	FKM for Plasma	3310-75*1

*1 Produced by Mitsubishi Cable Industries, Ltd.

• Part with changed seal material and leakage

Symbol	Changed part *2	Leakage [Pa · m ³ /s or less] *1	
		Internal	External
Nil	None	1.3 x 10 ⁻¹⁰ (FKM)	1.3 x 10 ⁻¹¹ (FKM)
A	②, ③, ④	1.3 x 10 ⁻⁸	1.3 x 10 ⁻⁹
B	②, ③	1.3 x 10 ⁻⁸	1.3 x 10 ⁻⁹
C	④	1.3 x 10 ⁻¹⁰ (FKM)	1.3 x 10 ⁻⁹
D	②	1.3 x 10 ⁻⁸	1.3 x 10 ⁻¹¹ (FKM)
E	②, ④	1.3 x 10 ⁻⁸	1.3 x 10 ⁻⁹

*1 Values at normal temperature, excluding gas permeation
*2 Refer to Construction on page 8 for changed part. Number corresponds with the parts number on the construction drawing.

To order something other than Nil (standard), list the symbols starting with X, followed by each symbol for body surface treatment, seal material, and then changed part.

Example) XLC-16-2M9NA-XAN1A

* The XLCV (With solenoid valve) is available as made to order. Please contact SMC for details.

Barrel Perfluoro® is a registered trademark of Matsumura Oil Co., Ltd.
Kalrez® is a registered trademark of E. I. du Pont de Nemours and Company or its affiliates.
Chemraz® is a registered trademark of Greene, Tweed Technologies, Inc.

Specifications

Model	XLC-16-2	XLC-25-2	XLC-40-2	XLC-50-2	XLC-63-2	XLC-80-2	
Valve type	Double acting (Dual operation), Pressurize to open/close						
Fluid	Inert gas under vacuum						
Operating temperature [°C]	XLC 5 to 60 (High-temperature type: 5 to 150)						
Operating pressure [Pa(abs)]	1 x 10 ⁻⁶ to atmospheric pressure						
Conductance [L/s]*1	5	14	45	80	160	200	
Leakage [Pa·m ³ /s]	Internal	For standard seal material (FKM): 1.3 x 10 ⁻¹⁰ at normal temperature, excluding gas permeation					
	External	For standard seal material (FKM): 1.3 x 10 ⁻¹¹ at normal temperature, excluding gas permeation					
Flange type	KF (NW)			KF (NW), K (DN)			
Principal materials	Body: Aluminum alloy, Bellows: Stainless steel 316L, Chief part: Stainless steel, FKM (Standard seal material)						
Surface treatment	External: Hard anodized Internal: Raw material						
Pilot pressure [MPa(G)]	0.3 to 0.6			0.4 to 0.6			
Pilot port size	XLC	M5		Rc1/8			
Weight [kg]	XLC	0.27	0.45	1.0	1.4	2.4	3.9

*1 Conductance is the value for the elbow with the same dimensions.

* For heater specifications, refer to Common Option [1] Heater on page 17.

Construction/Operation

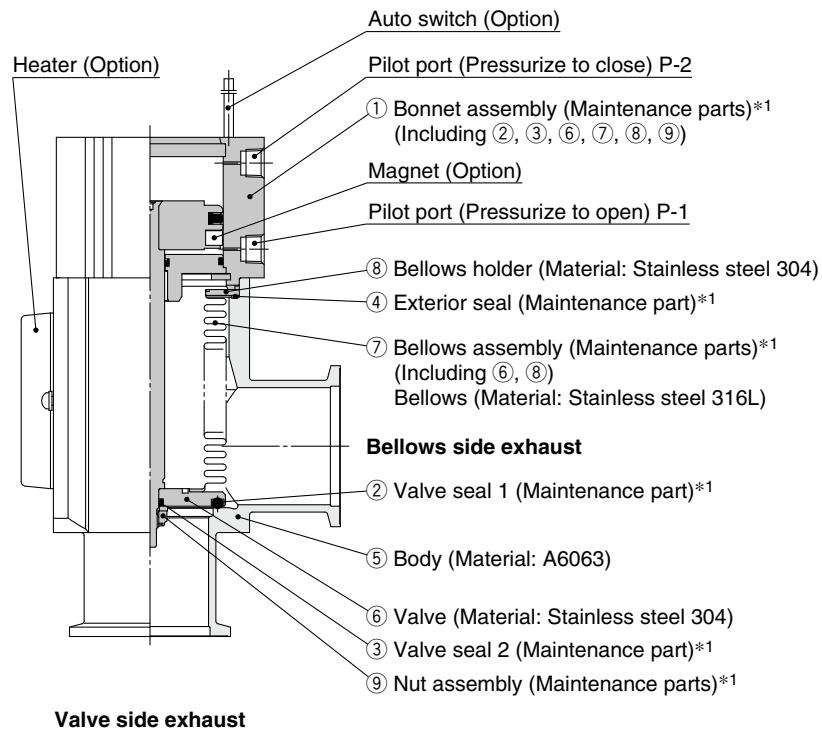

*1 Refer to Maintenance Parts on page 24.

<Working principle>

By applying pilot pressure from the pilot port P-1, the piston-coupled valve overcomes the operating force by the pressure, and the valve opens. (Pilot port P-2 is open.) Alternatively, by applying pilot pressure to pilot port P-2, the valve closes. (Pilot port P-1 is open.)

<Option>

Auto switch: The magnet activates the auto switch. With 2 auto switches, the open and closed positions are detected, and with 1 auto switch, either the open or closed position is detected. The temperature range is only available for general use (5 to 60°C).

Heater: Heating is performed simply using thermistors. The valve body can be heated to approximately 100 or 120°C, depending on the size of the product. The type and number of thermistors to be used will vary depending on the size and setting temperature. For the high-temperature type, the bonnet assembly is a heat-resistant structure.

XLC Series

Dimensions

XLC: Air operated

Size 16, 25, 40

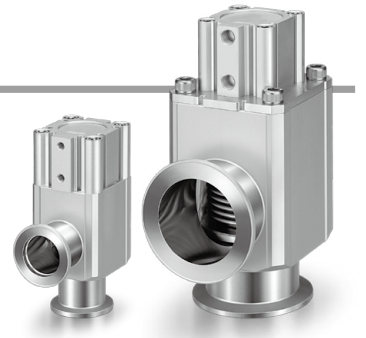
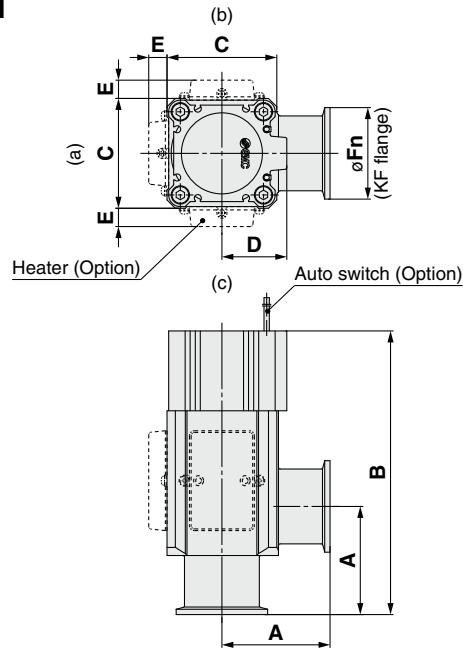

Size 50, 63, 80

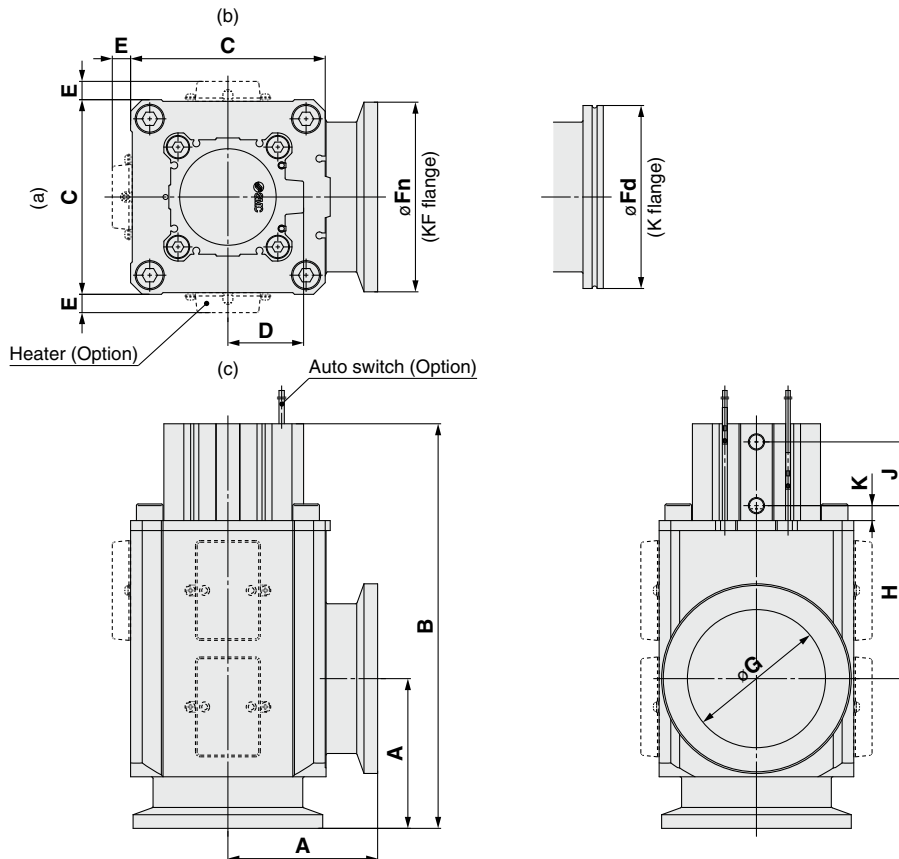

[mm]

Model	A	B	C	D	E*1	Fn	Fd	G	H	J	K
XLC-16-2	40	108	38	20	—	30	—	17	44	19	—
XLC-25-2	50	121	48	27	12	40	—	26	44	21	—
XLC-40-2	65	171	66	39	11	55	—	41	67	29	—
XLC-50-2	70	181	79	31	11	75	—	52	76	29	9
XLC-63-2	88	206	100	39	11	87	95	70	77	33	9
XLC-80-2	90	244	117	46	11	114	110	83	104	39	9

*1 The E dimension applies when the heater option is included. (Lead wire length: Approx. 1 m)

* (a), (b), (c) in the above drawing indicate heater mounting positions. Moreover, heater mounting positions will differ depending on the type of heater. For details, refer to Common Option [2] Mounting position of the heater on page 17.

Aluminum High Vacuum Angle Valve Normally Closed, O-ring Seal **XLF/XLHV Series**



XLF

How to Order

XLF - **16** **□** **□** **□** - 2 **M9N** **A** - **□**

① ② ③ ④ ⑤ ⑥ ⑦

① Flange size

Size
16
25
40
50
63
80

② Flange type

Symbol	Type	Applicable flange size
Nil	KF (NW)	16, 25, 40, 50, 63, 80
D	K (DN)	63, 80

③ Indicator/Pilot port direction

Symbol	Indicator	Pilot port direction
Nil	Without indicator	Flange side
A	With indicator	Flange side
F		Left flange surface
G		Rear flange surface
J		Right flange surface
K	Without indicator	Left flange surface
L		Rear flange surface
M		Right flange surface

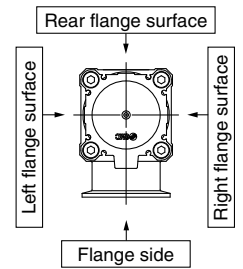

④ Temperature specifications/Heater

Symbol	Temperature	Heater
Nil	5 to 60°C	—
High-temperature type	H0	—
	H4	5 to 150°C With 100°C heater
	H5	5 to 150°C With 120°C heater

* Size 16 is not applicable to H4, H5. Size 25 is not applicable to H4.
* Heater cannot be retrofitted for the H0 type.

⑤ Auto switch type

Symbol	Model	Remarks
Nil	—	Without auto switch (without magnet)
M9N(M)(L)(Z)	D-M9N(M)(L)(Z)	Solid state auto switch
M9P(M)(L)(Z)	D-M9P(M)(L)(Z)	
M9B(M)(L)(Z)	D-M9B(M)(L)(Z)	
A90(L)	D-A90(L)	Reed auto switch (Not applicable to flange size 16)
A93(M)(L)(Z)	D-A93(M)(L)(Z)	—
M9//	—	Without auto switch (with magnet)

* For the high-temperature type, select the heat-resistant auto switch. (Refer to page 18.)
* Standard lead wire length is 0.5 m. Add M to the end of the part number for 1 m, L for 3 m, and Z for 5 m.
Example) -2M9NL

⑥ Number of auto switches/Mounting position

Symbol	Quantity	Mounting position
Nil	Without auto switch	—
A	2	Valve open/closed
B	1	Valve open
C	1	Valve closed

⑦ Body surface treatment/Seal material and changed parts

• Body surface treatment

Symbol	Surface treatment
Nil	External: Hard anodized Internal: Raw material
A	External: Hard anodized Internal: Oxalic acid anodized

• Seal material

Symbol	Seal material	Compound no.
Nil	FKM	1349-80*1
N1	EPDM	2101-80*1
P1	Barrel Perfluoro®	70W
Q1	Kalrez®	4079
R1	Chemraz®	SS592
R2		SS630
R3		SSE38
S1	VMQ	1232-70*1
T1	FKM for Plasma	3310-75*1

*1 Produced by Mitsubishi Cable Industries, Ltd.

• Part with changed seal material and leakage

Symbol	Changed part *2	Leakage [Pa · m ³ /s or less] *1	
		Internal	External
Nil	None	1.3 x 10 ⁻¹⁰ (FKM)	1.3 x 10 ⁻¹⁰ (FKM)
A	②, ③, ④	1.3 x 10 ⁻⁸	1.3 x 10 ⁻⁸
B	②, ③	1.3 x 10 ⁻⁸	1.3 x 10 ⁻¹⁰ (FKM)
C	④	1.3 x 10 ⁻¹⁰ (FKM)	1.3 x 10 ⁻⁸
D	②	1.3 x 10 ⁻⁸	1.3 x 10 ⁻¹⁰ (FKM)
E	②, ④	1.3 x 10 ⁻⁸	1.3 x 10 ⁻⁸

*1 Values at normal temperature, excluding gas permeation
*2 Refer to Construction on page 12 for changed part. Number corresponds with the parts number on the construction drawing.

To order something other than Nil (standard), list the symbols starting with X, followed by each symbol for body surface treatment, seal material, and then changed part.

Example) XLF-16-2M9NA-XAN1A

Barrel Perfluoro® is a registered trademark of Matsumura Oil Co., Ltd.
Kalrez® is a registered trademark of E. I. du Pont de Nemours and Company or its affiliates.
Chemraz® is a registered trademark of Greene, Tweed Technologies, Inc.

XLF/XLFV Series

Air Operated, With Solenoid Valve

Solenoid valve

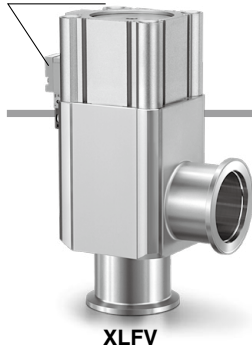

XLFV

How to Order

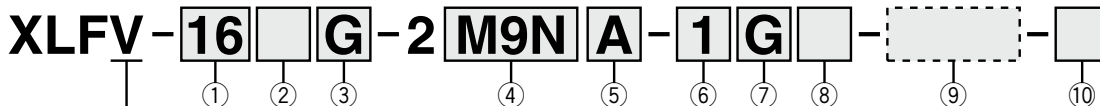

• Air operated, With solenoid valve

① Flange size

Size
16
25
40
50
63
80

② Flange type

Symbol	Type	Applicable flange size
Nil	KF (NW)	16, 25, 40, 50, 63, 80
D	K (DN)	63, 80

③ Indicator/Solenoid valve direction

Symbol	Indicator	Solenoid valve direction
F	With indicator	Left flange surface
G		Rear flange surface
J		Right flange surface
K	Without indicator	Left flange surface
L		Rear flange surface
M		Right flange surface

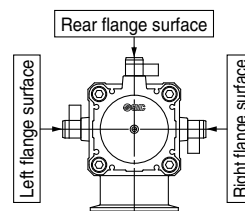

* M type plug connector (AC power supply) not attached for J, M of sizes 16 and 25.

④ Auto switch type

Symbol	Model	Remarks
Nil	—	Without auto switch (without magnet)
M9N(M)(L)(Z)	D-M9N(M)(L)(Z)	Solid state auto switch
M9P(M)(L)(Z)	D-M9P(M)(L)(Z)	
M9B(M)(L)(Z)	D-M9B(M)(L)(Z)	
A90(L)	D-A90(L)	Reed auto switch (Not applicable to flange size 16)
A93(M)(L)(Z)	D-A93(M)(L)(Z)	
M9//	—	Without auto switch (with magnet)

* Standard lead wire length is 0.5 m. Add M to the end of the part number for 1 m, L for 3 m, and Z for 5 m.

Example) -2M9NL

⑤ Number of auto switches/Mounting position

Symbol	Quantity	Mounting position
Nil	Without auto switch	—
A	2	Valve open/closed
B	1	Valve open
C	1	Valve closed

⑥ Rated voltage

		CE-compliant
1	100 VAC, 50/60 Hz	—
2	200 VAC, 50/60 Hz	—
3	110 VAC, 50/60 Hz	—
4	220 VAC, 50/60 Hz	—
5	24 VDC	○
6	12 VDC	○

⑦ Electrical entry

G	Grommet (Lead wire length 300 mm)
H	Grommet (Lead wire length 600 mm)
L	L type plug connector
M	M type plug connector

⑧ Light/surge voltage suppressor

Nil	None
S	With surge voltage suppressor
Z	With light/surge voltage suppressor
U	With light/surge voltage suppressor (Non-polar type)

* S type: Not available for AC

* U type: DC only

⑩ CE-compliant

Nil	—
Q	CE-compliant

⑨ Body surface treatment/Seal material and changed parts

• Body surface treatment

Symbol	Surface treatment
Nil	External: Hard anodized Internal: Raw material
A	External: Hard anodized Internal: Oxalic acid anodized

• Seal material

Symbol	Seal material	Compound no.
Nil	FKM	1349-80*1
N1	EPDM	2101-80*1
P1	Barrel Perfluoro®	70W
Q1	Kalrez®	4079
R1	Chemraz®	SS592
R2		SS630
R3		SSE38
S1	VMQ	1232-70*1
T1	FKM for Plasma	3310-75*1

*1 Produced by Mitsubishi Cable Industries, Ltd.

Barrel Perfluoro® is a registered trademark of Matsumura Oil Co., Ltd. Kalrez® is a registered trademark of E. I. du Pont de Nemours and Company or its affiliates. Chemraz® is a registered trademark of Greene, Tweed Technologies, Inc.

• Part with changed seal material and leakage

Symbol	Changed part *2	Leakage [Pa · m ³ /s or less] *1	
		Internal	External
Nil	None	1.3 x 10 ⁻¹⁰ (FKM)	1.3 x 10 ⁻¹¹ (FKM)
A	②, ③, ④	1.3 x 10 ⁻⁸	1.3 x 10 ⁻⁹
B	②, ③	1.3 x 10 ⁻⁸	1.3 x 10 ⁻⁹
C	④	1.3 x 10 ⁻¹⁰ (FKM)	1.3 x 10 ⁻⁹
D	②	1.3 x 10 ⁻⁸	1.3 x 10 ⁻¹¹ (FKM)
E	②, ④	1.3 x 10 ⁻⁸	1.3 x 10 ⁻⁹

*1 Values at normal temperature, excluding gas permeation

*2 Refer to Construction on page 12 for changed part. Number corresponds with the parts number on the construction drawing.

To order something other than Nil (standard), list the symbols starting with X, followed by each symbol for body surface treatment, seal material, and then changed part.

Example) XLFV-40L-2M9NA-1G-XAN1A

* With solenoid valve: Option specifications/Combinations

This model has indicator, auto switch, and K (DN) flange options, but high-temperature/heater options are not available.

* Solenoid valves

XLFV-16, 25, 40: SYJ319, XLFV-50, 63, 80: SYJ519

Example) SYJ319-1GS, etc.

For details, please contact your SMC sales representative.

** For option "Q," the solenoid valve should be a CE-compliant product.

Specifications

Model		XLF(V)-16-2	XLF(V)-25-2	XLF(V)-40-2	XLF(V)-50-2	XLF(V)-63-2	XLF(V)-80-2
Valve type		Normally closed (Pressurize to open, Spring seal)					
Fluid		Inert gas under vacuum					
Operating temperature [°C]	XLF	5 to 60 (High-temperature type: 5 to 150)					
	XLFV	5 to 50					
Operating pressure [Pa(abs)]		1 x 10 ⁻⁵ to atmospheric pressure					
Conductance [L/s]*1		5	14	45	80	160	200
Leakage [Pa·m ³ /s]	Internal	For standard seal material (FKM): 1.3 x 10 ⁻¹⁰ at normal temperature, excluding gas permeation					
	External	For standard seal material (FKM): 1.3 x 10 ⁻¹⁰ at normal temperature, excluding gas permeation					
Flange type		KF (NW)				KF (NW), K (DN)	
Principal materials*2		Body: Aluminum alloy, Chief part: Stainless steel, FKM (Standard seal material)					
Surface treatment		External: Hard anodized Internal: Raw material					
Pilot pressure [MPa(G)]		0.4 to 0.7					
Pilot port size	XLF	M5			Rc1/8		
	XLFV	M5: Port 1(P), 3(R)			Rc1/8: Port 1(P), M5: Port 3(R)		
Weight [kg]	XLF	0.29	0.49	1.2	1.9	3.3	5.7
	XLFV	0.34	0.54	1.3	2.0	3.4	5.8

*1 Conductance is the value for the elbow with the same dimensions.

*2 A coating of vacuum grease [Y-VAC2] is applied to the seal-material sliding portion of the vacuum part.

Construction/Operation

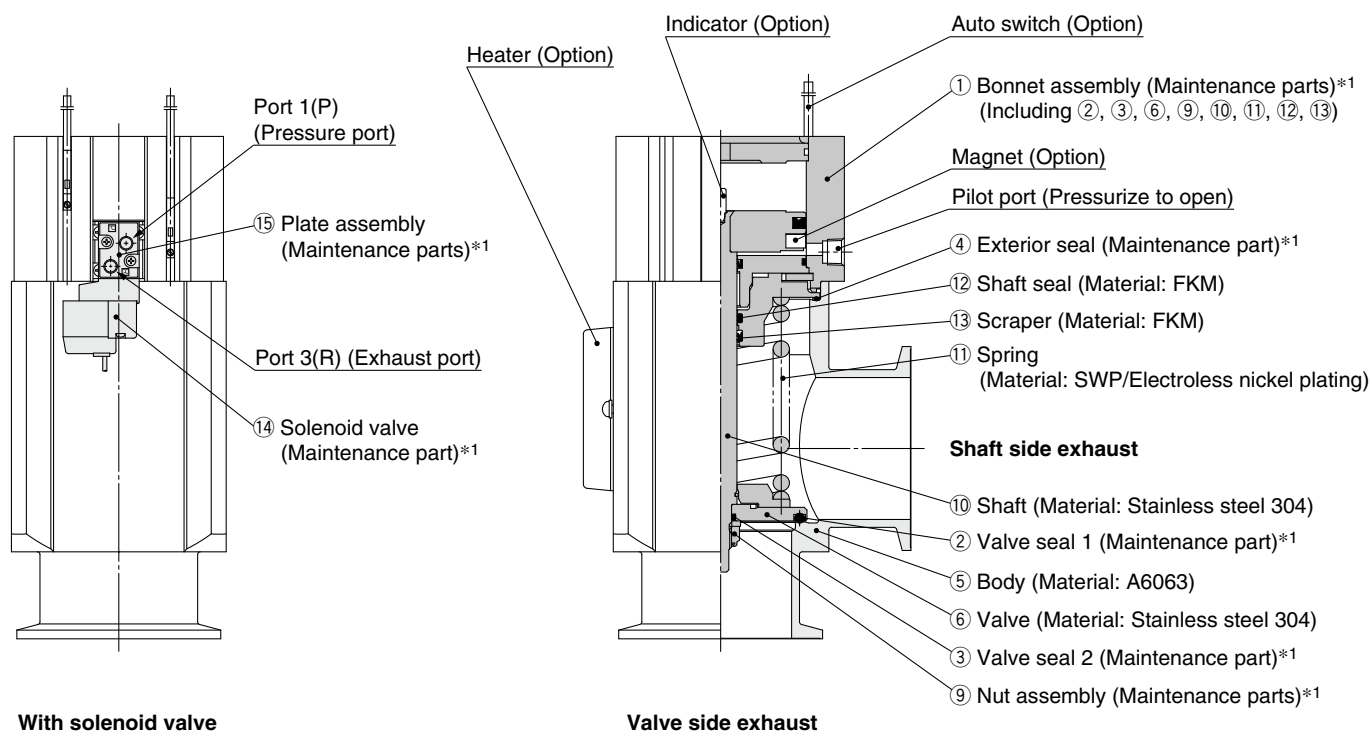

*1 Refer to Maintenance Parts on page 24.

<Working principle>

By applying pilot pressure from the pilot port, the piston-coupled valve overcomes the force of the spring or operating force by pressure, and the valve opens.

In the case of the XLFV, port 1(P) is normally pressurized, and the valve opens when the solenoid valve is turned ON and closes when it is turned OFF.

<Option>

Auto switch: The magnet activates the auto switch. With 2 auto switches, the open and closed positions are detected, and with 1 auto switch, either the open or closed position is detected. The temperature range is only available for general use (5 to 60°C).

Heater: Heating is performed simply using thermistors. The valve body can be heated to approximately 100 or 120°C, depending on the size of the product. The type and number of thermistors to be used will vary depending on the size and setting temperature. For the high-temperature type, the bonnet assembly is a heat-resistant structure.

Indicator: When the valve is open, a marker appears in the center of the upper surface of the bonnet.

XLF/XLFV Series

Dimensions

XLF: Air operated

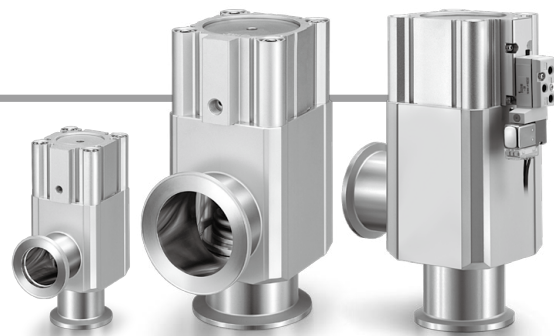
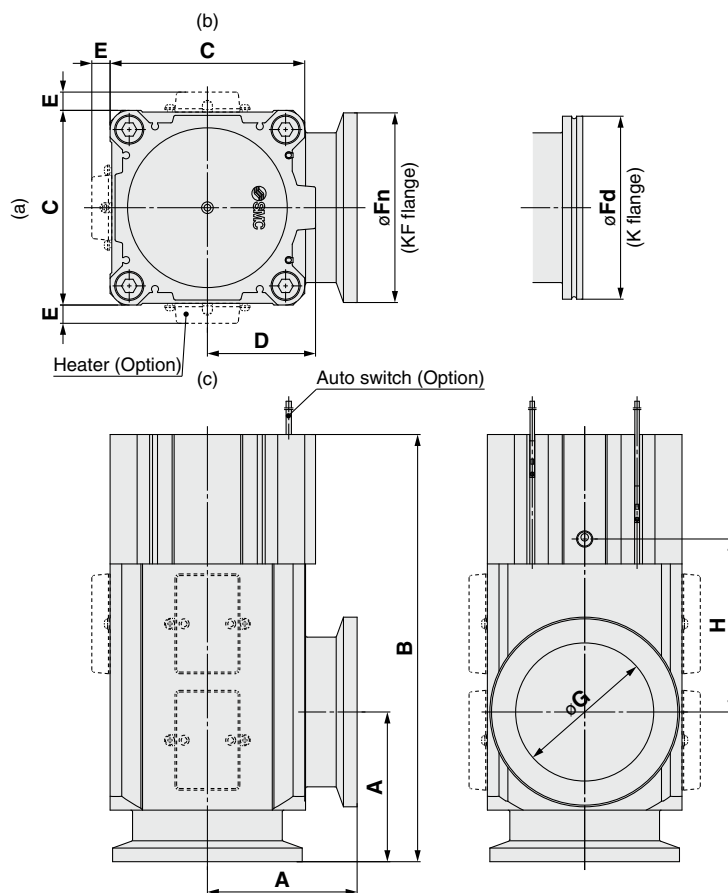

Model	A	B	C	D	E*1	F _n	F _d	G	H
XLF-16-2	40	108	38	20	—	30	—	17	44
XLF-25-2	50	121	48	27	12	40	—	26	44
XLF-40-2	65	171	66	39	11	55	—	41	67
XLF-50-2	70	185	79	46	11	75	—	52	72
XLF-63-2	88	212	100	55	11	87	95	70	76
XLF-80-2	90	257	117	65	11	114	110	83	104

*1 The E dimension applies when the heater option is included. (Lead wire length: Approx. 1 m)

* (a), (b), (c) in the above drawing indicate heater mounting positions. Moreover, heater mounting positions will differ depending on the type of heater.

For details, refer to Common Option [2] Mounting position of the heater on page 17.

XLFV: Air operated, With solenoid valve

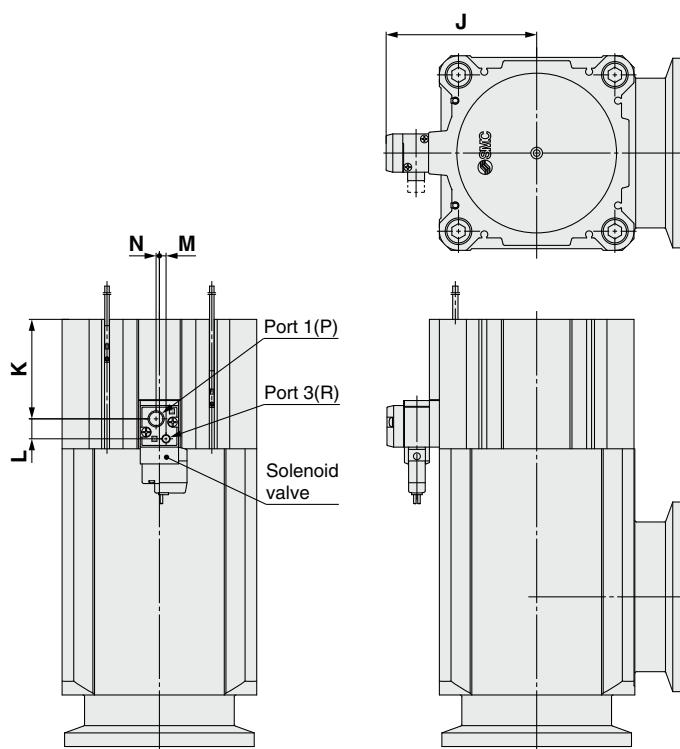

Model	J	K	L	M	N
XLFV-16-2	41	18.5	8.5	2.7	3
XLFV-25-2	45.5	22.5	8.5	2.7	3
XLFV-40-2	54.5	35	8.5	2.7	3
XLFV-50-2	71	35.5	12	4	2
XLFV-63-2	80.5	44	12	4	2
XLFV-80-2	90.5	60	12	4	2

Aluminum High Vacuum Angle Valve Double Acting, O-ring Seal **XLG Series**



How to Order

XLG - **16** **□** **□** **□** - 2 **M9N** **A** - **□**

① ② ③ ④ ⑤ ⑥ ⑦

① Flange size

Size
16
25
40
50
63
80

② Flange type

Symbol	Type	Applicable flange size
Nil	KF (NW)	16, 25, 40, 50, 63, 80
D	K (DN)	63, 80

③ Pilot port direction

Symbol	Pilot port direction
Nil	Flange side
K	Left flange surface
L	Rear flange surface
M	Right flange surface

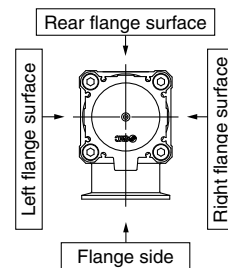

④ Temperature specifications/Heater

Symbol	Temperature	Heater
Nil	5 to 60°C	—
High-temperature type	H0	—
	H4	5 to 150°C With 100°C heater
	H5	5 to 150°C With 120°C heater

* Size 16 is not applicable to H4, H5. Size 25 is not applicable to H4.
* Heater cannot be retrofitted for the H0 type.

⑤ Auto switch type

Symbol	Model	Remarks
Nil	—	Without auto switch (without magnet)
M9N(M)(L)(Z)	D-M9N(M)(L)(Z)	Solid state auto switch
M9P(M)(L)(Z)	D-M9P(M)(L)(Z)	
M9B(M)(L)(Z)	D-M9B(M)(L)(Z)	
A90(L)	D-A90(L)	Reed auto switch (Not applicable to flange size 16)
A93(M)(L)(Z)	D-A93(M)(L)(Z)	
M9//	—	Without auto switch (with magnet)

* For the high-temperature type, select the heat-resistant auto switch. (Refer to page 18.)
* Standard lead wire length is 0.5 m. Add M to the end of the part number for 1 m, L for 3 m, and Z for 5 m.
Example) -2M9NL

⑥ Number of auto switches/Mounting position

Symbol	Quantity	Mounting position
Nil	Without auto switch	—
A	2	Valve open/closed
B	1	Valve open
C	1	Valve closed

⑦ Body surface treatment/Seal material and changed parts

• Body surface treatment

Symbol	Surface treatment
Nil	External: Hard anodized Internal: Raw material
A	External: Hard anodized Internal: Oxalic acid anodized

• Seal material

Symbol	Seal material	Compound no.
Nil	FKM	1349-80*1
N1	EPDM	2101-80*1
P1	Barrel Perfluoro®	70W
Q1	Kalrez®	4079
R1	Chemraz®	SS592
R2		SS630
R3		SSE38
S1	VMQ	1232-70*1
T1	FKM for Plasma	3310-75*1

*1 Produced by Mitsubishi Cable Industries, Ltd.

• Part with changed seal material and leakage

Symbol	Changed part ^{*2}	Leakage [Pa · m ³ /s or less] ^{*1}	
		Internal	External
Nil	None	1.3 x 10 ⁻¹⁰ (FKM)	1.3 x 10 ⁻¹⁰ (FKM)
A	②, ③, ④	1.3 x 10 ⁻⁸	1.3 x 10 ⁻⁸
B	②, ③	1.3 x 10 ⁻⁸	1.3 x 10 ⁻¹⁰ (FKM)
C	④	1.3 x 10 ⁻¹⁰ (FKM)	1.3 x 10 ⁻⁸
D	②	1.3 x 10 ⁻⁸	1.3 x 10 ⁻¹⁰ (FKM)
E	②, ④	1.3 x 10 ⁻⁸	1.3 x 10 ⁻⁸

*1 Values at normal temperature, excluding gas permeation

*2 Refer to Construction on page 15 for changed part. Number corresponds with the parts number on the construction drawing.

To order something other than Nil (standard), list the symbols starting with X, followed by each symbol for body surface treatment, seal material, and then changed part.

Example) XLG-16-2M9NA-XAN1A

* The XLGV (With solenoid valve) is available as made to order. Please contact SMC for details.

Barrel Perfluoro® is a registered trademark of Matsumura Oil Co., Ltd.
Kalrez® is a registered trademark of E. I. du Pont de Nemours and Company or its affiliates.
Chemraz® is a registered trademark of Greene, Tweed Technologies, Inc.

Specifications

Model	XLG-16-2	XLG-25-2	XLG-40-2	XLG-50-2	XLG-63-2	XLG-80-2	
Valve type	Double acting (Dual operation), Pressurize to open/close						
Fluid	Inert gas under vacuum						
Operating temperature [°C]	5 to 60 (High-temperature type: 5 to 150)						
Operating pressure [Pa(abs)]	Atmospheric pressure to 1×10^{-5}						
Conductance [L/s]*1	5	14	45	80	160	200	
Leakage [Pa·m ³ /s]	Internal	For standard seal material (FKM): 1.3×10^{-10} at normal temperature, excluding gas permeation					
	External	For standard seal material (FKM): 1.3×10^{-10} at normal temperature, excluding gas permeation					
Flange type	KF (NW)				KF (NW), K (DN)		
Principal materials*2	Body: Aluminum alloy, Chief part: Stainless steel, FKM (Standard seal material)						
Surface treatment	External: Hard anodized Internal: Raw material						
Pilot pressure [MPa(G)]	0.3 to 0.6			0.4 to 0.6			
Pilot port size	XLG	M5		Rc1/8			
Weight [kg]	XLG	0.26	0.44	1.0	1.5	2.4	4.1

*1 Conductance is the value for the elbow with the same dimensions.

*2 A coating of vacuum grease [Y-VAC2] is applied to the seal-material sliding portion of the vacuum part.

* For heater specifications, refer to Common Option [1] Heater on page 17.

Construction/Operation

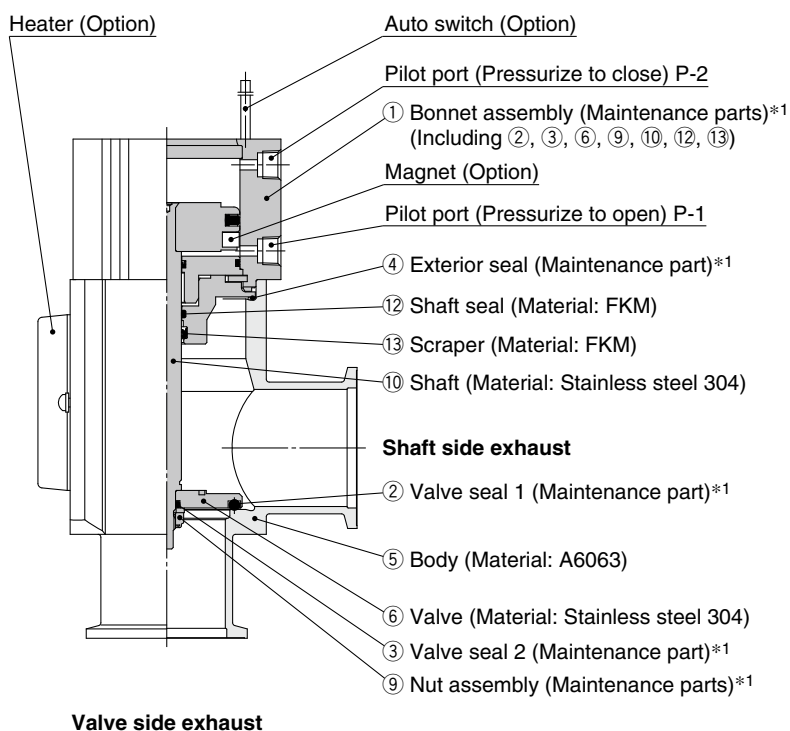

*1 Refer to Maintenance Parts on page 24.

<Working principle>

By applying pilot pressure from the pilot port P-1, the piston-coupled valve overcomes the operating force by the pressure, and the valve opens. (Pilot port P-2 is open.) Alternatively, by applying pilot pressure to pilot port P-2, the valve closes. (Pilot port P-1 is open.)

<Option>

Auto switch: The magnet activates the auto switch. With 2 auto switches, the open and closed positions are detected, and with 1 auto switch, either the open or closed position is detected. The temperature range is only available for general use (5 to 60°C).

Heater: Heating is performed simply using thermistors. The valve body can be heated to approximately 100 or 120°C, depending on the size of the product. The type and number of thermistors to be used will vary depending on the size and setting temperature. For the high-temperature type, the bonnet assembly is a heat-resistant structure.

Dimensions

XLG: Air operated

Size 16, 25, 40

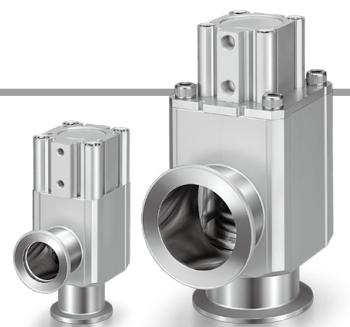
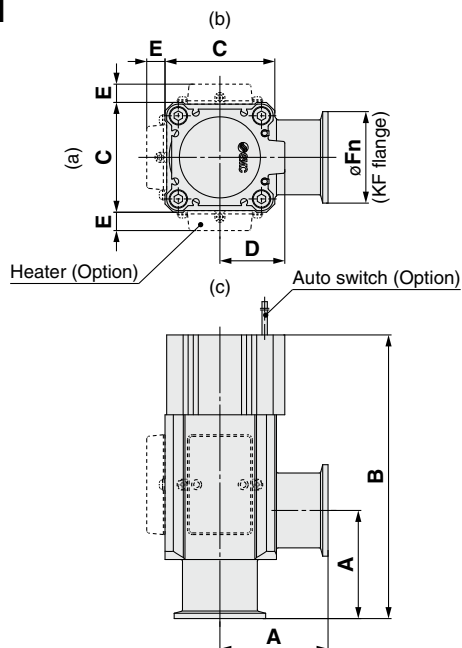

Size 50, 63, 80

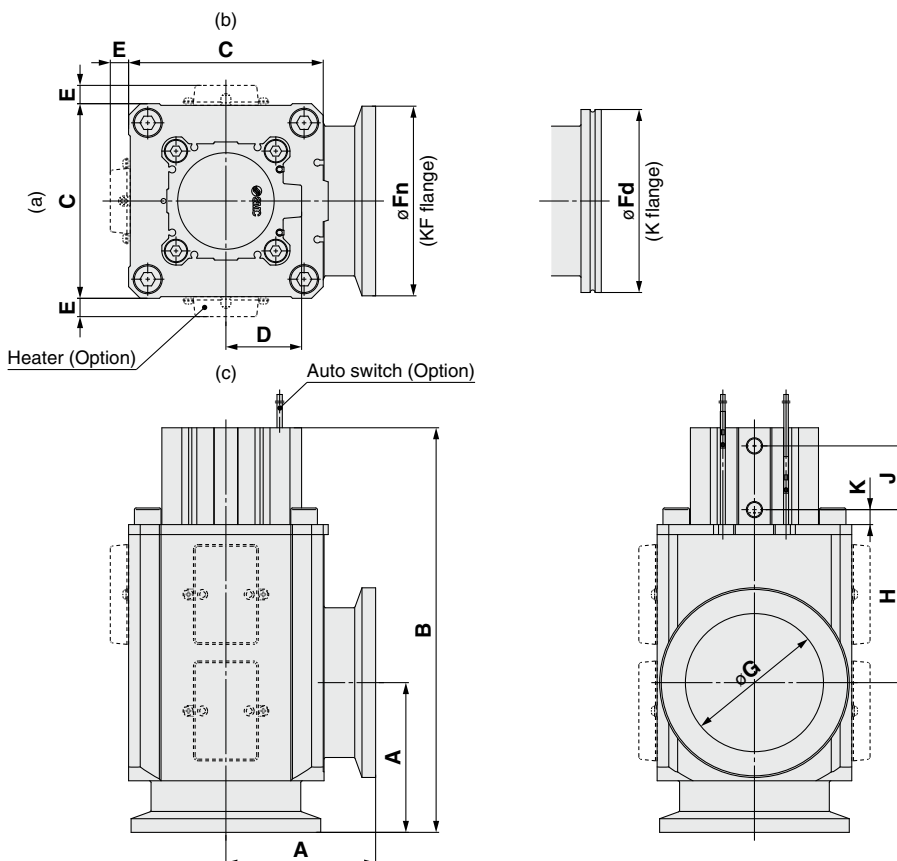

Model	A	B	C	D	E*1	Fn	Fd	G	H	J	K
XLG-16-2	40	108	38	20	—	30	—	17	44	19	—
XLG-25-2	50	121	48	27	12	40	—	26	44	21	—
XLG-40-2	65	171	66	39	11	55	—	41	67	29	—
XLG-50-2	70	181	79	31	11	75	—	52	76	29	9
XLG-63-2	88	206	100	39	11	87	95	70	77	33	9
XLG-80-2	90	244	117	46	11	114	110	83	104	39	9

*1 The E dimension applies when the heater option is included. (Lead wire length: Approx. 1 m)

* (a), (b), (c) in the above drawing indicate heater mounting positions. Moreover, heater mounting positions will differ depending on the type of heater. For details, refer to Common Option [2] Mounting position of the heater on page 17.

XL□ Series Common Option

1 Heater

Power consumption specifications are shown below.

Model		XL□-25-2	XL□-40-2	XL□-50-2	XL□-63-2	XL□-80-2	
Rated voltage for heater		90 to 240 VAC					
Heater assembly quantity used Heater power W (Nominal value) Inrush/Power consumption (Option symbol, Operating voltage)	Heater assembly quantity	—	1	1	1	1	
	H4 100°C	100 V	—	200/40	200/50	400/100	600/150
		200 V	—	800/40	800/50	1600/100	2400/150
	Heater assembly quantity	1	1	1	1	2	
	H5 120°C	100 V	200/40	400/70	400/80	600/130	800/180
		200 V	800/40	1600/80	1600/80	2400/130	3200/180

- * The inrush current of the heater flows for several tens of seconds when using 100 V, while it flows for several seconds when using 200 V. However, this inrush current will decrease shortly after.
- * When the product uses multiple heater assemblies, do not turn on the power to each heater assembly at the same time. Turn on the power to each heater assembly one-by-one at intervals of 30 sec. since the inrush current is large.
- * The heater temperature will decrease several % from the start of heating and then becomes stable. (The heater temperature may decrease approximately 5 to 10% due to individual differences.)
- * For mounting, refer to the Specific Product Precautions 2 on page 22. For details about quantity and type, refer to Maintenance Parts in the Specific Product Precautions 4 on page 24.

Inrush Current Flow Time (Reference)

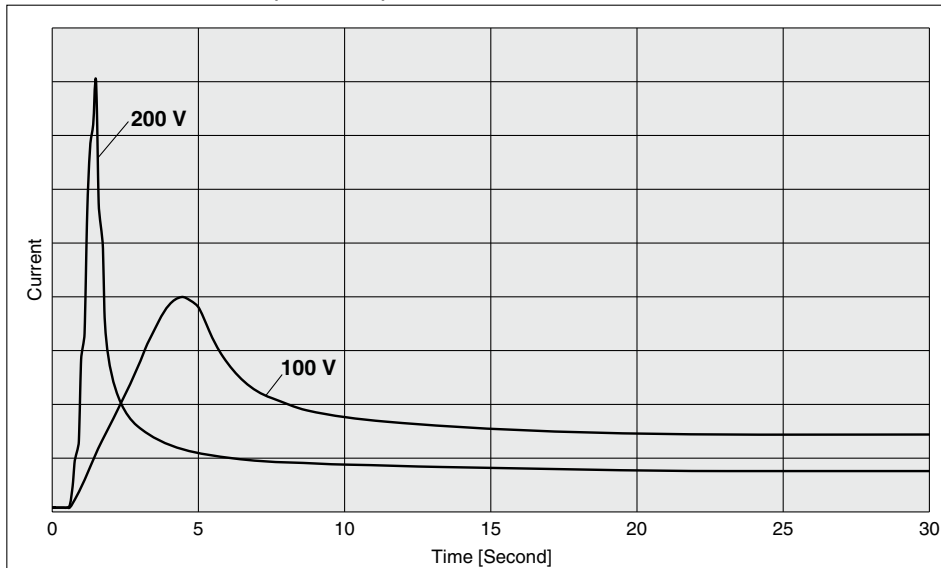

2 Mounting position of the heater

Heater symbol	XL□-25-2	XL□-40-2	XL□-50-2	XL□-63-2	XL□-80-2
H4 (100°C)	—	(a)	(a)	(b), (c)	(a), (b), (c)
H5 (120°C)	(a)	(b), (c)	(b), (c)	(a), (b), (c)	(b), (c)

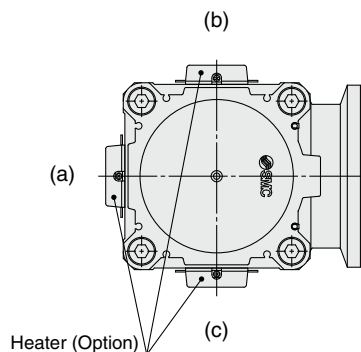

With Heat-resistant Auto Switch (D-M9□J)

- High-temperature type (Heater is mountable.)
- With heat-resistant 2-color indicator solid state auto switch

How to Order

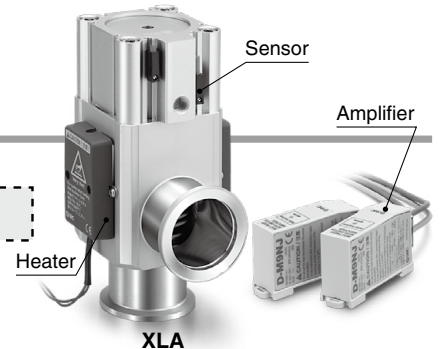
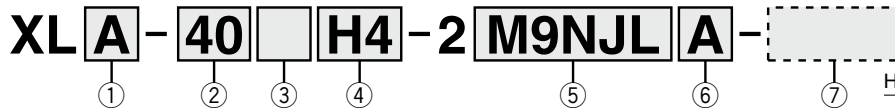

① Series

Symbol	Valve type	Shaft seal type
A	Single acting (N.C.)	Bellows seal
C	Double acting	Bellows seal
F	Single acting (N.C.)	O-ring seal
G	Double acting	O-ring seal

② Flange size

Size
25
40
50

③ Indicator/Pilot port direction

Symbol	Indicator	Pilot port direction
Nil	Without indicator	Flange side
A	With indicator	Flange side
F		Left flange surface
G		Rear flange surface
J		Right flange surface
K	Without indicator	Left flange surface
L		Rear flange surface
M		Right flange surface

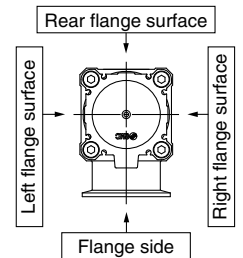

* A, F, G, and J are only for series A and F.

④ Temperature specifications/Heater

Symbol	Temperature	Heater
H0	5 to 150°C	—
H4		With 100°C heater
H5		With 120°C heater

* Size 25 is not applicable to H4.

⑥ Number of auto switches/Mounting position

Symbol	Quantity	Mounting position
A	2	Valve open/closed
B	1	Valve open
C	1	Valve closed

⑤ Auto switch type

Symbol	Model	Remarks
M9NJL	D-M9NJL	Lead wire length 3000 mm
M9NJZ	D-M9NJZ	Lead wire length 5000 mm
M9PJL	D-M9PJL	Lead wire length 3000 mm
M9PJZ	D-M9PJZ	Lead wire length 5000 mm
M9J/	—	Without auto switch (with magnet)

* For details about auto switches, refer to page 20.

⑦ Body surface treatment/Seal material and changed parts

• Body surface treatment

Symbol	Surface treatment
Nil	External: Hard anodized Internal: Raw material
A	External: Hard anodized Internal: Oxalic acid anodized

• Seal material

Symbol	Seal material	Compound no.
Nil	FKM	1349-80*1
N1	EPDM	2101-80*1
P1	Barrel Perfluoro®	70W
Q1	Kalrez®	4079
R1	Chemraz®	SS592
R2		SS630
R3		SSE38
S1	VMQ	1232-70*1
T1	FKM for Plasma	3310-75*1

*1 Produced by Mitsubishi Cable Industries, Ltd.

Barrel Perfluoro® is a registered trademark of Matsumura Oil Co., Ltd.
 Kalrez® is a registered trademark of E. I. du Pont de Nemours and Company or its affiliates.
 Chemraz® is a registered trademark of Greene, Tweed Technologies, Inc.

• Part with changed seal material and leakage

For XLA/XLC

Symbol	Changed part*2	Leakage [Pa·m ³ /s or less]*1	
		Internal	External
Nil	None	1.3 x 10 ⁻¹⁰ (FKM)	1.3 x 10 ⁻¹¹ (FKM)
A	②, ③, ④	1.3 x 10 ⁻⁸	1.3 x 10 ⁻⁹
B	②, ③	1.3 x 10 ⁻⁸	1.3 x 10 ⁻⁹
C	④	1.3 x 10 ⁻¹⁰ (FKM)	1.3 x 10 ⁻⁹
D	②	1.3 x 10 ⁻⁸	1.3 x 10 ⁻¹¹ (FKM)
E	②, ④	1.3 x 10 ⁻⁸	1.3 x 10 ⁻⁹

For XLF/XLG

Symbol	Changed part*2	Leakage [Pa·m ³ /s or less]*1	
		Internal	External
Nil	None	1.3 x 10 ⁻¹⁰ (FKM)	1.3 x 10 ⁻¹⁰ (FKM)
A	②, ③, ④	1.3 x 10 ⁻⁸	1.3 x 10 ⁻⁸
B	②, ③	1.3 x 10 ⁻⁸	1.3 x 10 ⁻¹⁰ (FKM)
C	④	1.3 x 10 ⁻¹⁰ (FKM)	1.3 x 10 ⁻⁸
D	②	1.3 x 10 ⁻⁸	1.3 x 10 ⁻¹⁰ (FKM)
E	②, ④	1.3 x 10 ⁻⁸	1.3 x 10 ⁻⁸

*1 Values at normal temperature, excluding gas permeation

*2 Refer to Construction on page 5 for changed part.

Number corresponds with the parts number on the construction drawing.

To order something other than Nil (standard), list the symbols starting with X, followed by each symbol for body surface treatment, seal material, and then changed part.

Example) XLA-25H0-2M9NJLA-XAN1A

XL□ Series

Dimensions

XLA/F (With D-M9□J□)

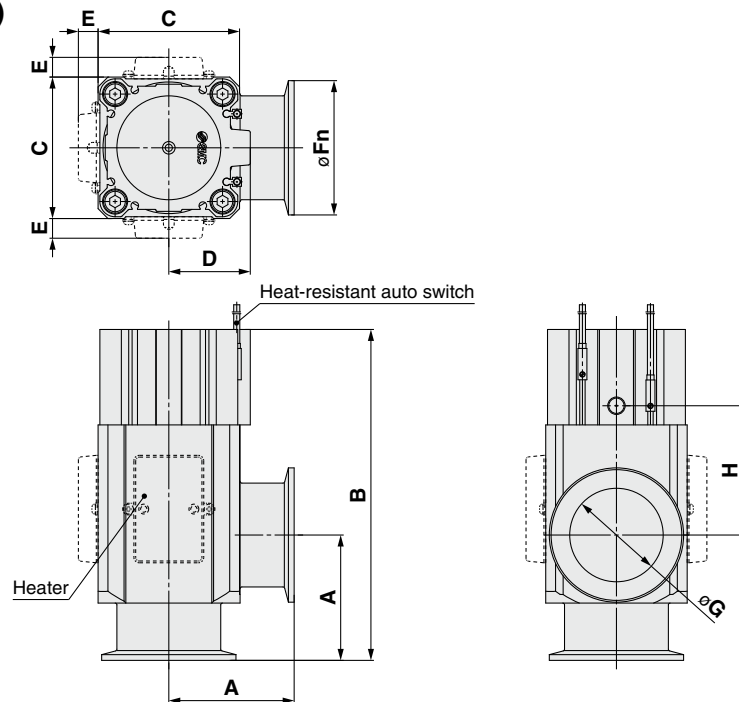

Series	Valve size	A	B	C	D	E	Fn	G	H
XLA XLF	25	50	121	48	27	12	40	26	44
	40	65	171	66	39	11	55	41	67
	50	70	185	79	46	11	75	52	72

XLC/G25, 40 (With D-M9□J□)

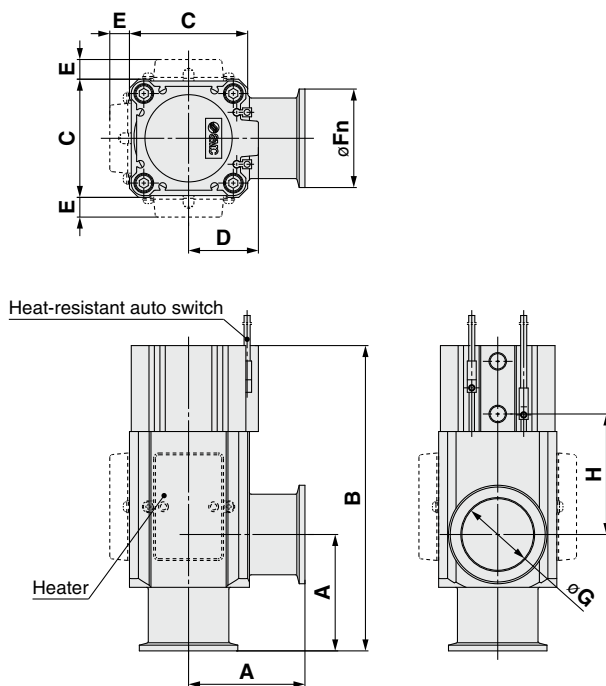

XLC/G50 (With D-M9□J□)

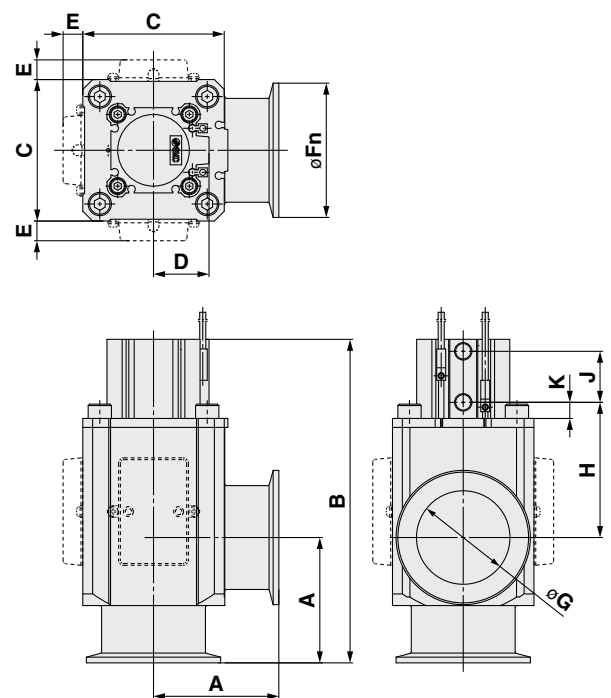

Series	Valve size	A	B	C	D	E	Fn	G	H	J	K
XLC XLG	25	50	121	48	27	12	40	26	44	21	—
	40	65	171	66	39	11	55	41	67	29	—
	50	70	185	79	31	11	75	52	76	29	9

Heat-resistant 2-Color Indicator Solid State Auto Switch: Direct Mounting Type D-M9NJ/D-M9PJ



Refer to the SMC website for details on products that are compliant with international standards.

Auto Switch Specifications

PLC: Programmable Logic Controller

D-M9NJ/D-M9PJ (With indicator light)		
Auto switch model	D-M9NJ	D-M9PJ
Output type	NPN	PNP
Power supply voltage	5, 12, 24 VDC (4.5 to 28 V)	
Current consumption	25 mA or less	
Load voltage	28 VDC or less	—
Load current	40 mA or less	
Internal voltage drop	0.8 V or less	
Leakage current	100 μA or less at 24 VDC	
Indicator light	Operating range Red LED illuminates Optimal operating range Green LED illuminates	
Ambient temperature	Sensor section: 0 to 150°C Amplifier section: 0 to 60°C	
Impact resistance	Sensor section: 1000 m/s ² Amplifier section: 300 m/s ²	
Standard	CE marking, RoHS	

Grommet

- Improved heat-resistant type
- The optimal operating range can be determined by the color of the light.
(Red → Green ← Red)



D-M9NJ



D-M9PJ

Oilproof Heavy-duty Lead Wire Specifications (Grommet)

Auto switch model		D-M9NJ	D-M9PJ
Sheath	Outside diameter [mm]	ø3.4	
	Number of cores	3 cores (Brown/Blue/Black)	
Insulator	Outside diameter [mm]	ø1.1	
	Effective area [mm ²]	0.2	
Conductor	Strand diameter [mm]	ø0.08	
	Minimum bending radius [mm] (Reference values)	21	

Weight

[g]

Auto switch model		D-M9NJ	D-M9PJ
Lead wire length	3 m (L)	160	
	5 m (Z)	200	

Dimensions

[mm]

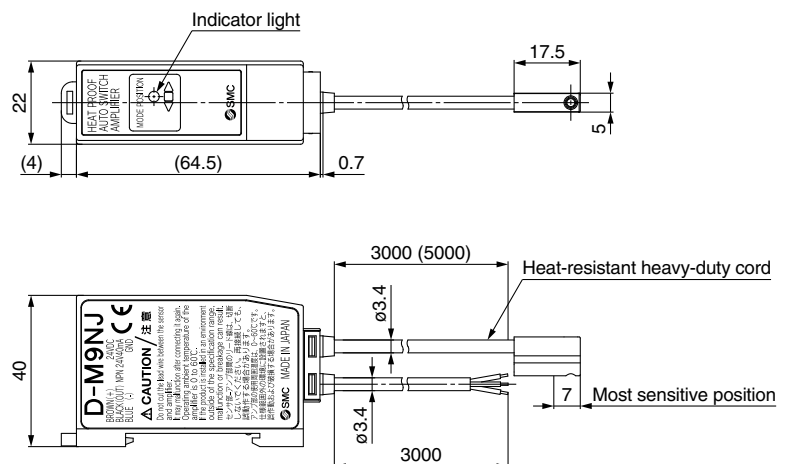



XL□ Series

Specific Product Precautions 1

Be sure to read this before handling the products. Refer to the back cover for safety instructions. For auto switch and 3/4/5 port solenoid valve precautions, refer to the “Handling Precautions for SMC Products” and the “Operation Manual” on the SMC website: <http://www.smcworld.com>

Piping

⚠ Caution

1. Refer to the Fittings & Tubing Precautions on the SMC website for handling One-touch fittings.

2. Preparation before piping

Before piping is connected, it should be thoroughly flushed out with air or washed to remove chips, cutting oil, and other debris from inside the pipe.

3. Winding of sealant tape

When connecting pipes, fittings, etc., be sure that chips from the pipe threads and sealing material do not enter the valve. Furthermore, when sealant tape is used, leave 1.5 to 2 thread ridges exposed at the end of the threads.

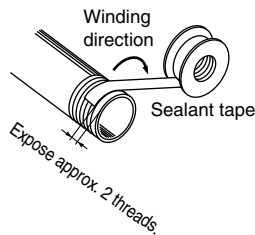

Air Supply

⚠ Warning

1. Type of fluids

Please consult with SMC when using the product in applications other than compressed air.

2. When there is a large amount of drainage

Compressed air containing a large amount of drainage can cause the malfunction of pneumatic equipment. An air dryer or water separator should be installed upstream from filters.

3. Drain flushing

If condensation in the drain bowl is not emptied on a regular basis, the bowl will overflow and allow the condensation to enter the compressed air lines. This causes the malfunction of pneumatic equipment. If the drain bowl is difficult to check and remove, the installation of a drain bowl with an auto drain option is recommended.

For compressed air quality, refer to the Product Selection Guide.

4. Use clean air.

Do not use compressed air that contains chemicals, synthetic oils that include organic solvents, salt, corrosive gases, etc., as it can cause damage or malfunction.

Air Supply

⚠ Caution

1. When extremely dry air is used as the fluid, degradation of the lubrication properties inside the equipment may occur, resulting in reduced reliability (or reduced service life) of the equipment. Please consult with SMC.

2. Install an air filter.

Install an air filter upstream near the valve. Select an air filter with a filtration size of 5 μm or smaller.

3. Take measures to ensure air quality, such as by installing an aftercooler, air dryer, or water separator.

Compressed air that contains a large amount of drainage can cause the malfunction of pneumatic equipment, such as valves. Therefore, take appropriate measures to ensure air quality, such as by providing an aftercooler, air dryer, or water separator.

4. Ensure that the fluid and ambient temperatures are within the specified range.

If the fluid temperature is 5°C or less, the moisture in the circuit could freeze, causing damage to the seals and equipment malfunction. Therefore, take appropriate measures to prevent freezing.

For compressed air quality, refer to the Product Selection Guide.

5. Precautionary measures against condensation

Moisture condensation can occur inside pneumatic systems due to a drop in temperature caused by the piping or operating conditions. This can degrade or wash away grease, resulting in a shortened service life or malfunction.

For details, refer to the catalog “Precautionary measures against condensation in a pneumatic system” (CAT.P-E01-11).



XL□ Series

Specific Product Precautions 2

Be sure to read this before handling the products. Refer to the back cover for safety instructions. For auto switch and 3/4/5 port solenoid valve precautions, refer to the “Handling Precautions for SMC Products” and the “Operation Manual” on the SMC website: <http://www.smcworld.com>

Air-operated Angle Valve XLA/XLC/XLF/XLG Series

Design

⚠ Warning

• All models

1. The body material is A6063, the bellows are made of stainless steel 316L, and the other metal material in the vacuum section is stainless steel 304.
The standard seal material in the vacuum section is FKM, but it can be changed to an other material if desired (refer to How to Order). Confirm that fluids are compatible with the materials before use.
2. Select materials for the actuation pressure piping, and heat resistance for fittings that are suitable for the applicable operating temperatures.

• For XLF/XLG

1. Vacuum grease is applied to the sliding part of the vacuum (Y-VAC2).

• Model with auto switch

1. The auto switch section temperature should not exceed 60°C.
2. For models with a heat-resistant auto switch, set the temperature of the auto switch section to 150°C or less.

• Model with heater

1. For models with a heater, a device should be installed to prevent overheating.
2. If using gases that cause a large amount of deposits, heat the valve body to prevent deposits in the valve.

• Model with solenoid valve

1. For models with a solenoid valve, the temperature of the solenoid valve section should be no greater than 50°C.

Selection

⚠ Caution

• All models

1. For high vacuum valves used in the main exhaust lines of flat panel display manufacturing equipment and other large manufacturing equipment, the XLF(V) or XLG(V) series, which employ O-ring seals for improved durability, is recommended.
2. When controlling product responsiveness, take note of the size and length of piping, as well as the flow rate characteristics of the pilot solenoid valve.
3. Pilot pressure should be kept within the specified range.
0.4 to 0.5 MPa is recommended.
4. Use within the operating pressure range.
5. Use within the operating temperature range.
6. The actuating piston chamber and the bellows chamber are directly connected to atmosphere.
Use in an environment where dust emissions will not cause problems. (Please consult with SMC if the release of dust must be avoided.)
7. If a product without auto switches (other than the built-in magnet type) is selected, please note that an auto switch cannot be retrofitted.
8. For models with a solenoid valve, keep residual voltage leakage to 3% or less of the rated voltage for DC and 8% or less of the rated voltage for AC.

Mounting

⚠ Caution

• All models

1. In high-humidity environments, keep valves in packaging until the time of installation.
2. For models with an auto switch or solenoid valve, secure the lead wires so that they have sufficient slack, without any unreasonable force applied to them.
3. Perform piping so that excessive force is not applied to the flange section. When there is vibration of heavy objects, attachments, etc., secure them so that torque is not applied directly to the flanges.
4. Vibration resistance allows for normal operation up to 30 m/s² (45 to 250 Hz), but continuous vibration may cause a decline in durability. Arrange piping to avoid excessive vibrations or shocks.

• High-temperature type (H0, H4, H5)

1. For models with a heater, take care not to damage the insulation components of the lead wires and the connector section.
2. The setting temperature for models with a heater should be established without a draft or heat insulation. It will change depending on conditions such as heat-retaining measures and the heating of other piping. Fine adjustment is not possible.
3. When installing heater accessories or mounting a heater, check insulation resistance at the actual operating temperature. Installation of a short circuit breaker, etc., is recommended.
4. When a product is to be heated, only the body section should be heated, excluding the bonnet section.
5. When a heater is in operation, the entire product becomes hot. Be careful not to touch it with bare hands, as burns will result.

• Model with solenoid valve

1. When mounting the fitting to the pilot port, mount it so that the solenoid valve and plate are secured at the same time.
Additionally, when replacing the solenoid valve, mount the screws in the same manner.

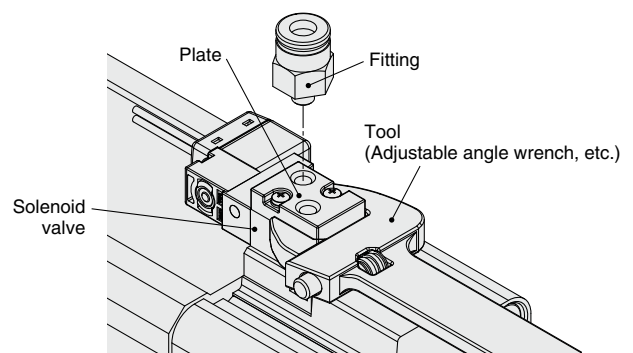



XL□ Series

Specific Product Precautions 3

Be sure to read this before handling the products. Refer to the back cover for safety instructions. For auto switch and 3/4/5 port solenoid valve precautions, refer to the “Handling Precautions for SMC Products” and the “Operation Manual” on the SMC website: <http://www.smcworld.com>

Air-operated Angle Valve XLA/XLC/XLF/XLG Series

Piping

⚠ Caution

1. Before mounting, clean the flange seal surface and the O-ring with ethanol, etc.
2. There is an indentation of 0.1 to 0.2 mm in order to protect the flange seal surface, and it should be handled so that the seal surface is not damaged in any way. When using an outer ring, be sure that the O-ring is compressed sufficiently. (There is basically no problem with the outer ring.)
3. Exhaust direction
During operation, the direction of the exhaust may be determined freely, but in cases where a flow is generated by the exhaust, a decline in durability may result. The exhaust direction shown in the figure below (bellows side exhaust) is recommended. Take all available precautions, as the life of the equipment is affected by the conditions of usage.
4. Valves may not be able to be mounted depending on the piping material type (clamp, etc.). Be sure to check the piping material before use.

Recommended exhaust direction
[Vacuum pump connected on bellows side]

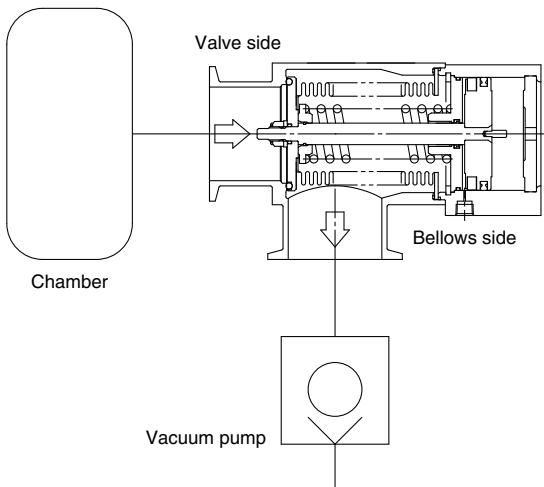

Maintenance

⚠ Warning

If there are any concerns about safety in regards to the fluid or reaction product (deposit) have someone with sufficient knowledge and experience (a specialist of the field) disassemble, clean, and assemble the products.

⚠ Caution

1. When removing deposits from a valve, take care not to damage any of its parts.
2. Replace the product or bonnet assembly when the end of its service life has approached.
3. If damage is suspected prior to the end of the product's service life, perform early maintenance. If there are scratches, dents, or cracks on the seals (bellows or valve) due to handling or operating conditions, replace the parts. For maintenance parts, refer to Construction or Maintenance Parts.
4. SMC specified parts should be used for service.
5. When removing valve seals or exterior seals, take care not to damage the sealing surfaces. When installing the valve seal or exterior seal, be sure that the O-ring is not twisted.
6. When the bellows assembly is replaced, do not hold the bellows directly.

Wiring

⚠ Caution

1. When the solenoid valve with a DC type light/surge voltage suppressor is electrically connected, check whether there is polarity. If there is polarity, incorrect polarity may cause damage to the elements inside the valve or power supply equipment, and malfunction may result.
2. When electric power is connected to the solenoid valve, be careful to apply the proper voltage. Improper voltage may cause a malfunction or the coil to burn out.
3. After completing the wiring, confirm that the connections are correct.
4. Secure the lead wire of the switch so that it has sufficient slack, without any excessive force applied to it.



XL Series Specific Product Precautions 4

Be sure to read this before handling the products. Refer to the back cover for safety instructions. For auto switch and 3/4/5 port solenoid valve precautions, refer to the "Handling Precautions for SMC Products" and the "Operation Manual" on the SMC website: <http://www.smcworld.com>

Air-operated Angle Valve XLA/XLC/XLF/XLG Series

Maintenance Parts

Air-operated angle valve

Bonnet Assembly

Series	Temperature specification	Indicator	Valve size					
			16	25	40	50	63	80
XLA	General use	None	XLA16-30-1-2	XLA25-30-1-2	XLA40-30-1-2	XLA50-30-1-2	XLA63-30-1-2	XLA80-30-1-2
		Yes	XLA16A-30-1-2	XLA25A-30-1-2	XLA40A-30-1-2	XLA50A-30-1-2	XLA63A-30-1-2	XLA80A-30-1-2
	High temperature	None	XLA16-30-1H-2	XLA25-30-1H-2	XLA40-30-1H-2	XLA50-30-1H-2	XLA63-30-1H-2	XLA80-30-1H-2
XLAV	General use	None	XLAV16-30-1-2	XLAV25-30-1-2	XLAV40-30-1-2	XLAV50-30-1-2	XLAV63-30-1-2	XLAV80-30-1-2
		Yes	XLAV16A-30-1-2	XLAV25A-30-1-2	XLAV40A-30-1-2	XLAV50A-30-1-2	XLAV63A-30-1-2	XLAV80A-30-1-2
	High temperature	None	XLC16-30-1-2	XLC25-30-1-2	XLC40-30-1-2	XLC50-30-1-2	XLC63-30-1-2	XLC80-30-1-2
XLC	General use	None	XLC16-30-1-2	XLC25-30-1-2	XLC40-30-1-2	XLC50-30-1-2	XLC63-30-1-2	XLC80-30-1-2
		Yes	XLC16A-30-1-2	XLC25A-30-1-2	XLC40A-30-1-2	XLC50A-30-1-2	XLC63A-30-1-2	XLC80A-30-1-2
	High temperature	None	XLC16-30-1H-2	XLC25-30-1H-2	XLC40-30-1H-2	XLC50-30-1H-2	XLC63-30-1H-2	XLC80-30-1H-2
XLF	General use	None	XLF16-30-1-2	XLF25-30-1-2	XLF40-30-1-2	XLF50-30-1-2	XLF63-30-1-2	XLF80-30-1-2
		Yes	XLF16A-30-1-2	XLF25A-30-1-2	XLF40A-30-1-2	XLF50A-30-1-2	XLF63A-30-1-2	XLF80A-30-1-2
	High temperature	None	XLF16-30-1H-2	XLF25-30-1H-2	XLF40-30-1H-2	XLF50-30-1H-2	XLF63-30-1H-2	XLF80-30-1H-2
XLFV	General use	None	XLFV16-30-1-2	XLFV25-30-1-2	XLFV40-30-1-2	XLFV50-30-1-2	XLFV63-30-1-2	XLFV80-30-1-2
		Yes	XLFV16A-30-1-2	XLFV25A-30-1-2	XLFV40A-30-1-2	XLFV50A-30-1-2	XLFV63A-30-1-2	XLFV80A-30-1-2
	High temperature	None	XLG16-30-1-2	XLG25-30-1-2	XLG40-30-1-2	XLG50-30-1-2	XLG63-30-1-2	XLG80-30-1-2
XLG	General use	None	XLG16-30-1-2	XLG25-30-1-2	XLG40-30-1-2	XLG50-30-1-2	XLG63-30-1-2	XLG80-30-1-2
	High temperature	None	XLG16-30-1H-2	XLG25-30-1H-2	XLG40-30-1H-2	XLG50-30-1H-2	XLG63-30-1H-2	XLG80-30-1H-2

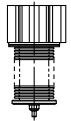

Bonnet assembly

- * In cases where the material of the valve seal 1, 2 is anything other than the standard (FKM: Compound no. 1349-80: made by Mitsubishi Cable Industries, Ltd.), add suffix symbol for the seal material (as shown below) to the end of the part number.
- * An auto switch magnet is not installed. In cases where an auto switch magnet is installed, add M9// to the end of the part number. (Not available for the high-temperature type)
- * Auto switch and solenoid valve are not attached. When a product with an auto switch and solenoid valve is required, add the symbols for the auto switch and solenoid valve to the end of the part number.
- * Bonnet assembly does not include exterior seal. Order separately if it is required.

Bellows Assembly/Nut Assembly

Description (Construction no.)	Valve size					
	16	25	40	50	63	80
Bellows assembly ⑦	XL1A16-2-101□	XL1A25-2-101□	XL1A40-2-101□	XL1A50-2-101□	XL1A63-2-101□	XL1A80-2-101□
Nut assembly ⑨	XL1A16-10-1	XL1A25-10-1	XL1A40-10-1	XL1A50-10-1	XL1A63-10-1	XL1A80-10-1



Bellows assembly

- * Bellows assembly includes the valve seal 1 (Standard material: FKM). (It does not include the valve seal 2.)
- * In cases where the material of the valve seal 1 is anything other than the standard (FKM: Compound no. 1349-80: made by Mitsubishi Cable Industries, Ltd.), add suffix symbol for the seal material (as shown below) to the end of the part number (In place of □).
- * Refer to the Construction section of each series for component part numbers.

Exterior Seal/Valve Seal 1, 2

Description (Construction no.)	Material	Valve size					
		16	25	40	50	63	80
Exterior seal ④	Standard	AS568-025V	AS568-030V	AS568-035V	AS568-039V	AS568-043V	AS568-045V
	Special	AS568-025□	AS568-030□	AS568-035□	AS568-039□	AS568-043□	AS568-045□
Valve seal 1 ②	Standard	B2401-V15V	B2401-V24V	B2401-P42V	AS568-227V	AS568-233V	B2401-V85V
	Special	B2401-V15□	B2401-V24□	B2401-P42□	AS568-227□	AS568-233□	B2401-V85□
Valve seal 2 ③	Standard	B2401-P4V	B2401-P5V	B2401-P6V	B2401-P8V		B2401-P10V
	Special	B2401-P4□	B2401-P5□	B2401-P6□	B2401-P8□		B2401-P10□

- * In cases where the seal material is anything other than the standard (FKM: Compound no. 1349-80: made by Mitsubishi Cable Industries, Ltd.), add suffix symbol for the seal material (as shown below) to the end of the part number (In place of □).
- * Refer to the Construction section of each series for component part numbers.

Table 1: Suffix Symbol for Seal Material

Symbol	-XN1	-XP1	-XQ1	-XR1	-XR2	-XR3	-XS1	-XT1
Seal material	EPDM	Barrel Perfluoro®	Kalrez®		Chemraz®		VMQ	FKM for Plasma
Compound no.	2101-80*1	70W	4079	SS592	SS630	SSE38	1232-70*1	3310-75*1

*1 Produced by Mitsubishi Cable Industries, Ltd.

Heater (CE)

Temperature specification	Valve size					
	25	40	50	63	80	
H4 (100°C)	—	XL1A25-60S-1	XL1A25-60S-1	XL1A25-60S-2	XL1A25-60S-3	
H5 (120°C)	XL1A25-60S-1	XL1A25-60S-2	XL1A25-60S-2	XL1A25-60S-3	XL1A25-60S-2 (2 sets)	

Example) For the XLA-80H5-2 with a heater, 2 sets of the XL1A25-60S-2 are required.

Solenoid Valve/Plate Assembly

Series	Description (Construction no.)	Valve size					
		16	25	40	50	63	80
XLAV XLFV	Solenoid valve ⑭	SYJ319-□□ (SYJ519-□□ only for XLFV-50-2)				SYJ519-□□	
	Plate assembly ⑮	XLAV16-90-2 (XLAV63-90-1 only for XLFV-50-2)				XLAV63-90-1	

- * The □□ at the end of the solenoid valve part number is the selection symbol for voltage, electrical entry, and other specifications. For details about selection symbols, refer to the Web Catalog.
- * The plate assembly includes the plate, gasket, and mounting screws.

Safety Instructions

These safety instructions are intended to prevent hazardous situations and/or equipment damage. These instructions indicate the level of potential hazard with the labels of “**Caution**,” “**Warning**” or “**Danger**.” They are all important notes for safety and must be followed in addition to International Standards (ISO/IEC)*1), and other safety regulations.

 **Caution:** **Caution** indicates a hazard with a low level of risk which, if not avoided, could result in minor or moderate injury.

 **Warning:** **Warning** indicates a hazard with a medium level of risk which, if not avoided, could result in death or serious injury.

 **Danger :** **Danger** indicates a hazard with a high level of risk which, if not avoided, will result in death or serious injury.

*1) ISO 4414: Pneumatic fluid power – General rules relating to systems.
ISO 4413: Hydraulic fluid power – General rules relating to systems.
IEC 60204-1: Safety of machinery – Electrical equipment of machines.
(Part 1: General requirements)
ISO 10218-1: Manipulating industrial robots – Safety.
etc.

Warning

1. The compatibility of the product is the responsibility of the person who designs the equipment or decides its specifications.

Since the product specified here is used under various operating conditions, its compatibility with specific equipment must be decided by the person who designs the equipment or decides its specifications based on necessary analysis and test results. The expected performance and safety assurance of the equipment will be the responsibility of the person who has determined its compatibility with the product. This person should also continuously review all specifications of the product referring to its latest catalog information, with a view to giving due consideration to any possibility of equipment failure when configuring the equipment.

2. Only personnel with appropriate training should operate machinery and equipment.

The product specified here may become unsafe if handled incorrectly. The assembly, operation and maintenance of machines or equipment including our products must be performed by an operator who is appropriately trained and experienced.

3. Do not service or attempt to remove product and machinery/equipment until safety is confirmed.

1. The inspection and maintenance of machinery/equipment should only be performed after measures to prevent falling or runaway of the driven objects have been confirmed.
2. When the product is to be removed, confirm that the safety measures as mentioned above are implemented and the power from any appropriate source is cut, and read and understand the specific product precautions of all relevant products carefully.
3. Before machinery/equipment is restarted, take measures to prevent unexpected operation and malfunction.

4. Contact SMC beforehand and take special consideration of safety measures if the product is to be used in any of the following conditions.

1. Conditions and environments outside of the given specifications, or use outdoors or in a place exposed to direct sunlight.
2. Installation on equipment in conjunction with atomic energy, railways, air navigation, space, shipping, vehicles, military, medical treatment, combustion and recreation, or equipment in contact with food and beverages, emergency stop circuits, clutch and brake circuits in press applications, safety equipment or other applications unsuitable for the standard specifications described in the product catalog.
3. An application which could have negative effects on people, property, or animals requiring special safety analysis.
4. Use in an interlock circuit, which requires the provision of double interlock for possible failure by using a mechanical protective function, and periodical checks to confirm proper operation.

Caution

1. The product is provided for use in manufacturing industries.

The product herein described is basically provided for peaceful use in manufacturing industries.
If considering using the product in other industries, consult SMC beforehand and exchange specifications or a contract if necessary.
If anything is unclear, contact your nearest sales branch.

Limited warranty and Disclaimer/ Compliance Requirements

The product used is subject to the following “Limited warranty and Disclaimer” and “Compliance Requirements”.

Read and accept them before using the product.

Limited warranty and Disclaimer

1. The warranty period of the product is 1 year in service or 1.5 years after the product is delivered, whichever is first.*2)
Also, the product may have specified durability, running distance or replacement parts. Please consult your nearest sales branch.
2. For any failure or damage reported within the warranty period which is clearly our responsibility, a replacement product or necessary parts will be provided.
This limited warranty applies only to our product independently, and not to any other damage incurred due to the failure of the product.
3. Prior to using SMC products, please read and understand the warranty terms and disclaimers noted in the specified catalog for the particular products.

*2) Vacuum pads are excluded from this 1 year warranty.

A vacuum pad is a consumable part, so it is warranted for a year after it is delivered.
Also, even within the warranty period, the wear of a product due to the use of the vacuum pad or failure due to the deterioration of rubber material are not covered by the limited warranty.

Compliance Requirements

1. The use of SMC products with production equipment for the manufacture of weapons of mass destruction (WMD) or any other weapon is strictly prohibited.
2. The exports of SMC products or technology from one country to another are governed by the relevant security laws and regulations of the countries involved in the transaction. Prior to the shipment of a SMC product to another country, assure that all local rules governing that export are known and followed.

Caution

SMC products are not intended for use as instruments for legal metrology.

Measurement instruments that SMC manufactures or sells have not been qualified by type approval tests relevant to the metrology (measurement) laws of each country. Therefore, SMC products cannot be used for business or certification ordained by the metrology (measurement) laws of each country.

Revision History

Edition B	* The XLC/F/G series has been added. * Number of pages increased from 12 to 24.	UR
Edition C	* The XLAV-2/FV-2 has been added. * Heat-resistant 2-color indicator solid state auto switch has been added to the high-temperature type. * Number of pages increased from 24 to 28.	VO

Safety Instructions

Be sure to read the “Handling Precautions for SMC Products” (M-E03-3) and “Operation Manual” before use.