

# Stainless steel High Vacuum Angle/In-line Valve

# Series XMA, XYA

## Normally Closed/Bellows Seal



### How to Order

Angle type

XMA — 16 — — — M9N A — —

In-line type

XYA — 25 — — — M9N A — —

1 2 3 4 5 6 7

### 1. Flange size

Size	XMA	XYA
16	✓	—
25	✓	✓
40	✓	✓
50	✓	✓
63	✓	✓
80	✓	✓

### 3. Indicator/Pilot port direction

#### XMA

Symbol	Indicator	Pilot port direction
Nil	Without indicator	Flange side
A	With indicator	Flange side
F		Left flange surface
G		Rear flange surface
J		Right flange surface
K	Without indicator	Left flange surface
L	Without indicator	Rear flange surface
M	Without indicator	Right flange surface

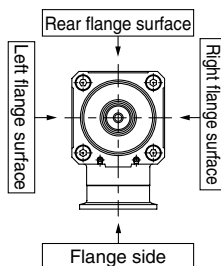

### 4. Temperature specifications

Symbol	Temperature range
Nil	5 to 60°C
H0	5 to 150°C

### 6. No. of auto switches/Detecting position

Symbol	Quantity	Detecting position
Nil	Without auto switch	—
A	2 pcs.	Valve open/closed
B	1 pc.	Valve open
C	1 pc.	Valve closed

### 7. Seal material and its changed part

#### Seal material

Symbol	Seal material	Compound No.
Nil	FKM	1349-80*
N1	EPDM	2101-80*
P1	BARREL PERFLUORO®	70W
Q1	Kalrez®	4079
R1	CHEMRAZ®	SS592
R2		SS630
R3		SSE38
S1	VMQ	1232-70*
T1	FKM for Plasma	3310-75*
U1	ULTIC ARMOR®	UA4640

\*: Produced by Mitsubishi Cable Industries, Ltd.

### 2. Flange type

#### XMA

Symbol	Type	Applicable flange size
Nil	KF (NW)	16, 25, 40, 50, 63, 80
D	K (DN)	63, 80
C	CF	16 (034), 40 (070), 63 (114)

#### XYA

Nil	KF (NW)	25, 40, 50, 63, 80
D	K (DN)	63, 80

#### XYA

Symbol	Indicator	Pilot port direction
Nil	Without indicator	Rear flange side
A	With indicator	Rear flange side
F		Left flange surface
J		Right flange surface
K	Without indicator	Left flange surface
M	Without indicator	Right flange surface

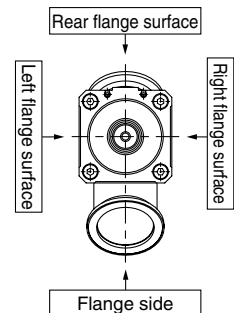

### 5. Auto switch type

Symbol	Auto switch	Remarks
Nil	—	Without auto switch (without built-in magnet)
M9N (L)	D-M9N (L)	Solid state switch
M9P (L)	D-M9P (L)	
M9B (L)	D-M9B (L)	
A90 (L)	D-A90 (L)	Reed switch
A93 (L)	D-A93 (L)	(Flange size 16 is not available.)
M9//	—	Without auto switch (with built-in magnet)

Auto switches cannot be mounted in the case of high temperature types (temperature specifications H0). The standard lead wire length is 0.5m. For 3m, "L" is added at the end of the part number. Ex.) -M9NL

### Part numbers indicating changed seal material and leakage

Symbol	Changed part <sup>Note 2)</sup>	Leakage Pa m <sup>3</sup> /s or less <sup>Note 1)</sup>	
		Internal	External
Nil	—	1.3 x 10 <sup>-10</sup> (FKM)	1.3 x 10 <sup>-11</sup> (FKM)
A	2, 3	1.3 x 10 <sup>-8</sup>	1.3 x 10 <sup>-9</sup>
B	2	1.3 x 10 <sup>-8</sup>	1.3 x 10 <sup>-11</sup> (FKM)
C	3	1.3 x 10 <sup>-10</sup> (FKM)	1.3 x 10 <sup>-9</sup>

Note 1) Values at ambient temperatures, excluding gas permeation.

Note 2) Refer to parts number of "Construction" on the page 2 for changed part. Number indicates parts number of "Construction" accordingly.

To order something else "Nil" (standard), list the symbols starting with "X", followed by each symbol for "seal material" and then "changed parts" at last.

Ex.) XMA-16-M9NA-XN1A

# Series XMA, XYA

## Specifications

Model	XMA-16	XMA-25 XYA-25	XMA-40 XYA-40	XMA-50 XYA-50	XMA-63 XYA-63	XMA-80 XYA-80	
Flange (valve) size	16, CF034	25	40, CF070	50	63, CF114	80	
Valve type	Normally closed (Pressurize to open, spring seal)						
Fluid	Inactive gas under vacuum						
Operating temperature °C	5 to 60 (High temperature type: 5 to 150)						
Operating pressure Pa	Atmospheric pressure to $1 \times 10^{-6}$						
Conductance $\ell/s$ <sup>Note 1)</sup>	5	14	45	80	160	200	
Leakage $\text{Pa}\cdot\text{m}^3/\text{s}$	Internal	$1.3 \times 10^{-10}\{1 \times 10^{-10}\}$ at ambient temperature, excluding gas permeation					
	External	$1.3 \times 10^{-11}\{1 \times 10^{-11}\}$ at ambient temperature, excluding gas permeation					
Operating time s	0.05	0.1	0.21	0.24	0.26	0.28	
Flange type	KF (NW), CF	KF (NW)	KF (NW), CF	KF (NW)	KF (NW), K (DN), CF	KF (NW), K (DN)	
Principle materials	Body: SCS13 (Conforms to Stainless steel SUS304) Bellows: Stainless steel SUS316L Bellows holder: Stainless steel SUS304. FKM (Standard seal material)						
Pilot pressure MPa	0.4 to 0.7						
Pilot port size	M5			Rc 1/8			
Service life (million cycles)	200 (FKM seal material)						
Weight kg <sup>Note 2)</sup>	XMA	0.33(0.37)	0.61	1.40(1.76)	2.00	3.60(4.96)	6.20
	XYA	—	0.66	1.42	2.40	4.30	7.70

Note 1) Conductance is the value for the molecular flow of an elbow having the same dimensions.

Note 2) Figures in ( ) indicates the weight of CF, conflate fittings.

## Construction

### XMA/Angle type

### XYA/In-line type

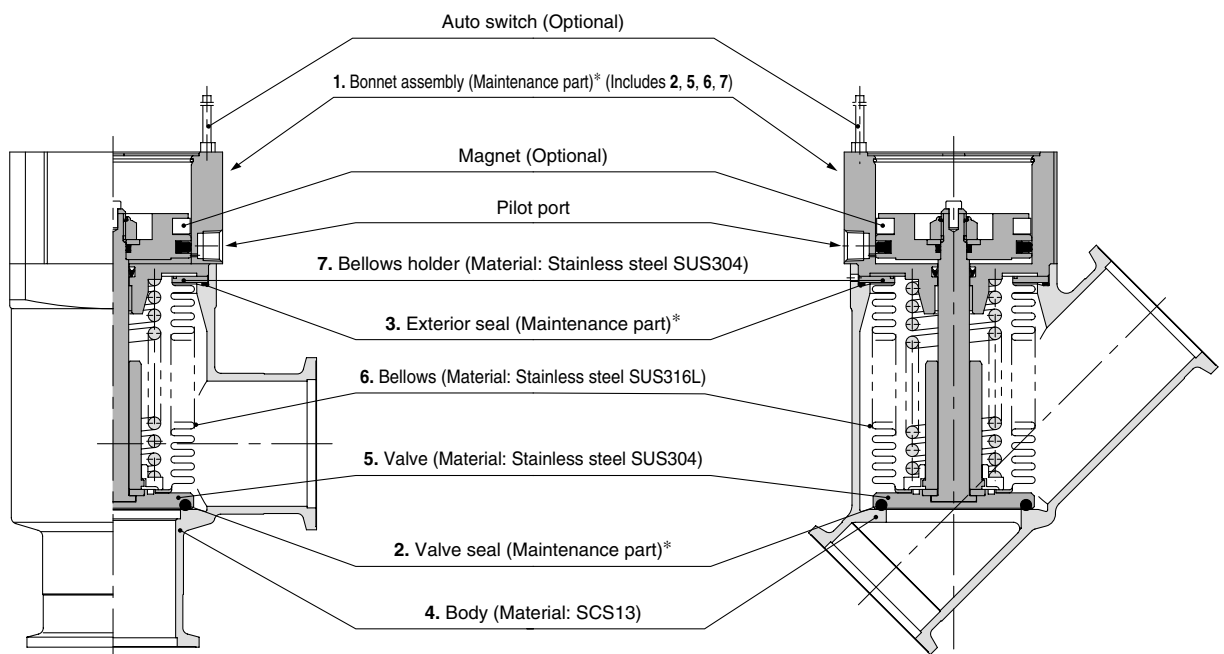

\* Refer to the page 22 for the maintenance parts.

## Dimensions

### XMA/Angle type

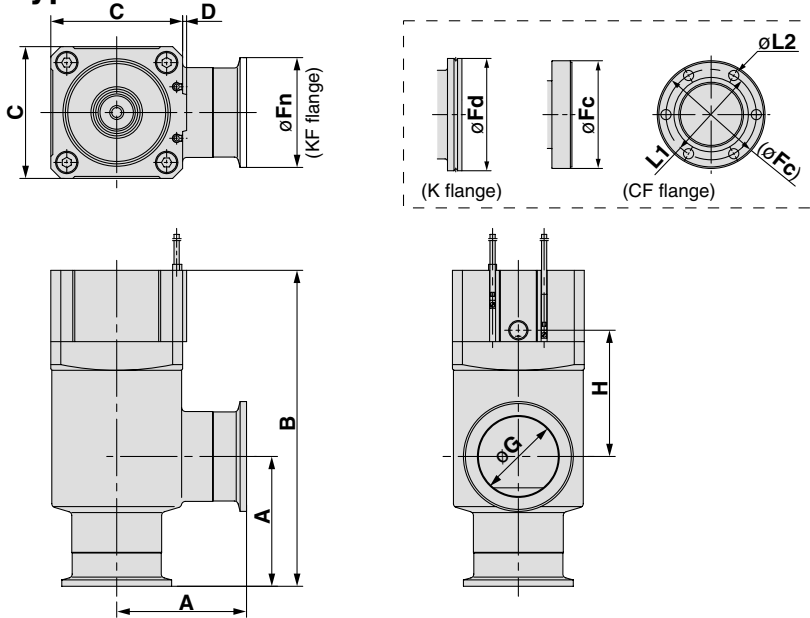

Model	A	B	C	D	F <sub>n</sub>	F <sub>d</sub>	F <sub>c</sub>	G	H	P.C.D	L1	L2
<b>XMA-16</b>	40	103	38	1	30	—	34	17	40	P.C.D 27	—	6- $\phi$ 4.4
<b>XMA-25</b>	50	113	48	1	40	—	—	26	39	—	—	—
<b>XMA-40</b>	65	158	66	2	55	—	70	41	63	P.C.D 58.7	—	6- $\phi$ 6.6
<b>XMA-50</b>	70	170	79	2	75	—	—	52	68	—	—	—
<b>XMA-63</b>	88	196	100	3	87	95	114	70	69	P.C.D 92.1	—	8- $\phi$ 8.4
<b>XMA-80</b>	90	235	117	3	114	110	—	83	96	—	—	—

(mm)

### XYA/In-line type

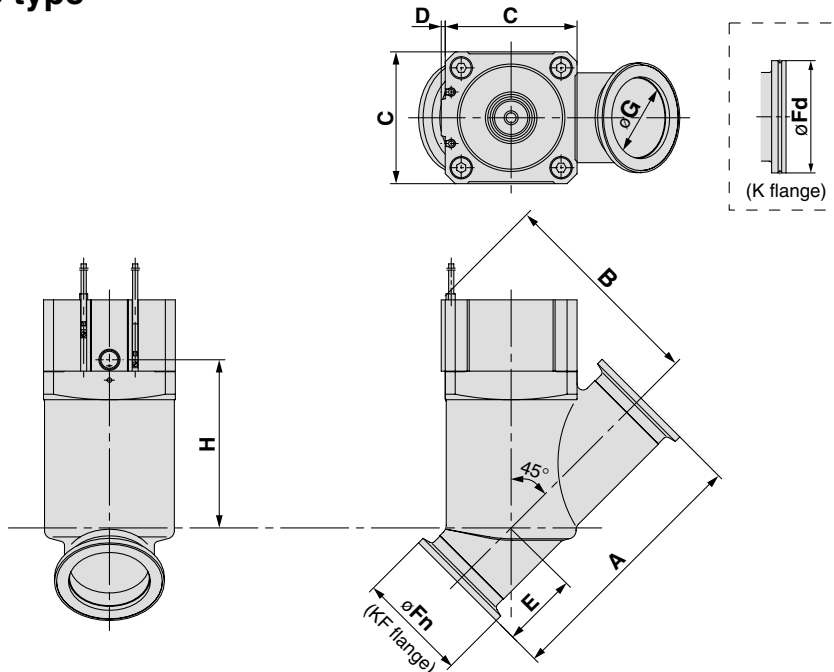

Model	A	B	C	D	E	F <sub>n</sub>	F <sub>d</sub>	G	H
<b>XYA-25</b>	100.2	79.5	48	1	23.5	40	—	26	64
<b>XYA-40</b>	130	106	66	2	38	55	—	41	84
<b>XYA-50</b>	178	119	79	2	53	75	—	52	95
<b>XYA-63</b>	209	149	100	3	61	87	95	70	118
<b>XYA-80</b>	268	178	117	3	80	114	110	83	142

(mm)

# Stainless steel High Vacuum Angle/In-line Valve

# Series XMC, XYC

## Double Acting/Bellows Seal



### How to Order

Angle type

XMC — 16 [ ] [ ] [ ] — M9N A [ ] [ ]

In-line type

XYC — 25 [ ] [ ] [ ] — M9N A [ ] [ ]

1 2 3 4 5 6 7



### 1. Flange size

Size	XMC	XYC
16	✓	—
25	✓	✓
40	✓	✓
50	✓	✓
63	✓	✓
80	✓	✓

### 3. Pilot port direction

#### XMC

Symbol	Pilot port direction
Nil	Flange side
K	Left flange surface
L	Rear flange surface
M	Right flange surface

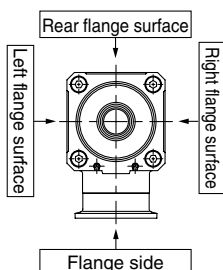

### 4. Temperature specifications

Symbol	Temperature range
Nil	5 to 60°C
H0	5 to 150°C

### 6. No. of auto switches/Detecting position

Symbol	Quantity	Detecting position
Nil	Without auto switch	—
A	2 pcs.	Valve open/closed
B	1 pc.	Valve open
C	1 pc.	Valve closed

### 7. Seal material and its changed part

#### Seal material

Symbol	Seal material	Compound No.
Nil	FKM	1349-80*
N1	EPDM	2101-80*
P1	BARREL PERFLUORO®	70W
Q1	Kalrez®	4079
R1	CHEMRAZ®	SS592
R2		SS630
R3		SSE38
S1	VMQ	1232-70*
T1	FKM for Plasma	3310-75*
U1	ULTIC ARMOR®	UA4640

\*: Produced by Mitsubishi Cable Industries, Ltd.

### 2. Flange type

#### XMC

Symbol	Type	Applicable flange size
Nil	KF (NW)	16, 25, 40, 50, 63, 80
D	K (DN)	63, 80
C	CF	16 (034), 40 (070), 63 (114)

#### XYC

Nil	KF (NW)	25, 40, 50, 63, 80
D	K (DN)	63, 80

#### XYC

Symbol	Pilot port direction
Nil	Rear flange surface
K	Left flange surface
M	Right flange surface

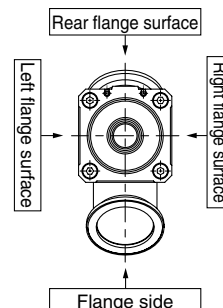

### 5. Auto switch type

Symbol	Auto switch	Remarks
Nil	—	Without auto switch (without built-in magnet)
M9N (L)	D-M9N (L)	Solid state switch
M9P (L)	D-M9P (L)	
M9B (L)	D-M9B (L)	
A90 (L)	D-A90 (L)	Reed switch (Flange size 16 is not available.)
A93 (L)	D-A93 (L)	
M9//	—	Without auto switch (with built-in magnet)

Auto switches cannot be mounted in the case of high temperature types (temperature specifications H0). The standard lead wire length is 0.5m. For 3m, "L" is added at the end of the part number. Ex.) -M9NL

### Part numbers indicating changed seal material and leakage

Symbol	Changed part <sup>Note 2)</sup>	Leakage Pa m <sup>3</sup> /s or less <sup>Note 1)</sup>	
		Internal	External
Nil	—	1.3 x 10 <sup>-10</sup> (FKM)	1.3 x 10 <sup>-11</sup> (FKM)
A	2, 3	1.3 x 10 <sup>-8</sup>	1.3 x 10 <sup>-9</sup>
B	2	1.3 x 10 <sup>-8</sup>	1.3 x 10 <sup>-11</sup> (FKM)
C	3	1.3 x 10 <sup>-10</sup> (FKM)	1.3 x 10 <sup>-9</sup>

Note 1) Values at ambient temperatures, excluding gas permeation.

Note 2) Refer to parts number of "Construction" on the page 5 for changed part. Number indicates parts number of "Construction" accordingly.

To order something else "Nil" (standard), list the symbols starting with "X", followed by each symbol for "seal material" and then "changed parts" at last.

Ex.) XMC-16-M9NA-XN1A

## Specifications

Model	XMC-16	XMC-25 XYC-25	XMC-40 XYC-40	XMC-50 XYC-50	XMC-63 XYC-63	XMC-80 XYC-80	
Flange (valve) size	16, CF034	25	40, CF070	50	63, CF114	80	
Valve type	Double acting (Dual operation), pressurize to open/close						
Fluid	Inactive gas under vacuum						
Operating temperature °C	5 to 60 (High temperature type: 5 to 150)						
Operating pressure Pa	Atmospheric pressure to $1 \times 10^{-6}$						
Conductance $\ell/s$ <small>Note 1)</small>	5	14	45	80	160	200	
Leakage $\text{Pa}\cdot\text{m}^3/\text{s}$	Internal	$1.3 \times 10^{-10}\{1 \times 10^{-10}\}$ at ambient temperatures, excluding gas permeation					
	External	$1.3 \times 10^{-11}\{1 \times 10^{-11}\}$ at ambient temperatures, excluding gas permeation					
Operating time s	0.08	0.15	0.35	0.4	0.54	0.7	
Flange type	KF (NW), CF	KF (NW)	KF (NW), CF	KF (NW)	KF (NW), K (DN), CF	KF (NW), K (DN)	
Principle materials	Body: SCS13 (Conforms to Stainless steel SUS304) Bellows: Stainless steel SUS316L Bellows holder: Stainless steel SUS304. FKM (Standard seal material)						
Pilot pressure MPa	0.3 to 0.6						
Pilot port size	M5			Rc 1/8			
Service life (million cycles)	200 (FKM seal material)						
Weight kg <small>Note 2)</small>	XMC	0.36 (0.40)	0.62	1.40 (1.76)	2.10	3.80 (5.16)	6.30
	XYC	—	0.67	1.42	2.50	4.50	7.80

Note 1) Conductance is the value for the molecular flow of an elbow having the same dimensions.

Note 2) Figures in ( ) indicates the weight of CF, conflate fittings.

## Construction

### XMC/Angle type

### XYC/In-line type

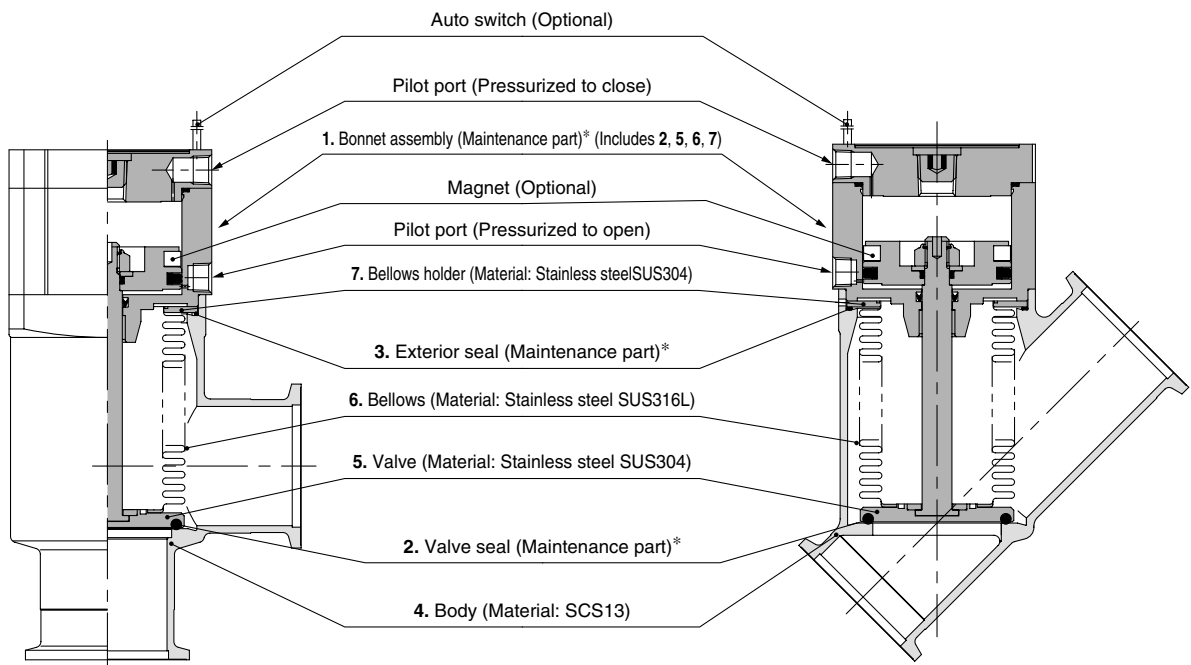

\* Refer to the page 22 for the maintenance parts.

# Series XMC, XYC

## Dimensions

### XMC/Angle type

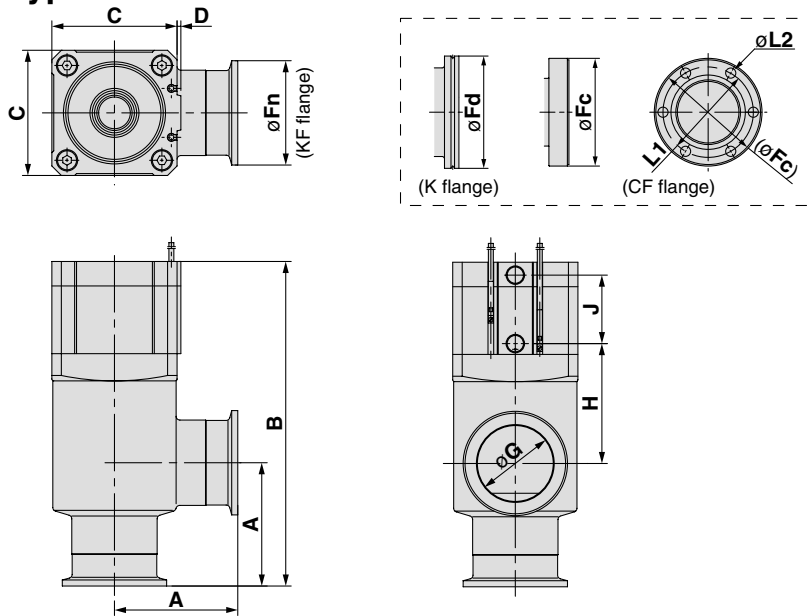

Model	A	B	C	D	Fn	Fd	Fc	G	H	J	P.C.D L1	L2
XMC-16	40	110	38	1	30	—	34	17	40	26	P.C.D 27	6- $\phi$ 4.4
XMC-25	50	120	48	1	40	—	—	26	39	28	—	—
XMC-40	65	171	66	2	55	—	70	41	63	36	P.C.D 58.7	6- $\phi$ 6.6
XMC-50	70	183	79	2	75	—	—	52	68	38	—	—
XMC-63	88	209	100	3	87	95	114	70	69	45	P.C.D 92.1	8- $\phi$ 8.4
XMC-80	90	250	117	3	114	110	—	83	96	56	—	—

### XYC/In-line type

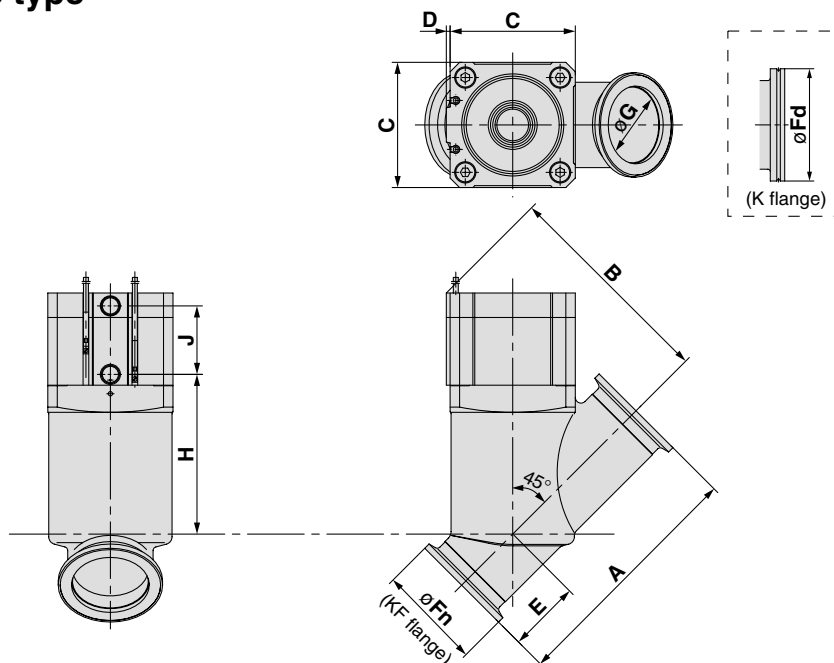

Model	A	B	C	D	E	Fn	Fd	G	H	J
XYC-25	100.2	85	48	1	23.5	40	—	26	64	28
XYC-40	130	115	66	2	38	55	—	41	84	36
XYC-50	178	129	79	2	53	75	—	52	95	38
XYC-63	209	158	100	3	61	87	95	70	118	45
XYC-80	268	189	117	3	80	114	110	83	142	56

# Stainless steel High Vacuum Angle/In-line Valve

# Series *XMD, XYD*

## 2 Stage Control, Single Acting/Bellows, O-ring Seal

PAT.



### How to Order

Angle type

XMD — 25 □ □ □ — M9N A — □ □ □ □ □ □ □

In-line type

XYD — 25 □ □ □ — M9N A — □ □ □ □ □ □ □

1 2 3 4 5 6 7



### 1. Flange size

Size	XMD	XYD
25	▽	▽
40	▽	▽
50	▽	▽
63	▽	▽
80	▽	▽

### 3. Pilot port direction

#### XMD

Symbol	Pilot port direction
Nil	Flange side
K	Left flange surface
L	Rear flange surface
M	Right flange surface

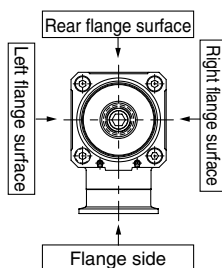

### 4. Temperature specifications

Symbol	Temperature range
Nil	5 to 60°C
H0	5 to 150°C

### 6. No. of auto switches/Detecting position

Symbol	Quantity	Detecting position
Nil	Without auto switch	—
A	2 pcs.	Valve open/closed
B	1 pc.	Valve open
C	1 pc.	Valve closed

### 7. Seal material and its changed part

#### Seal material

Symbol	Seal material	Compound No.
Nil	FKM	1349-80*
N1	EPDM	2101-80*
P1	BARREL PERFLUORO®	70W
Q1	Kalrez®	4079
R1	CHEMRAZ®	SS592
R2		SS630
R3		SSE38
S1	VMQ	1232-70*
T1	FKM for Plasma	3310-75*
U1	ULTIC ARMOR®	UA4640

The material used in the sliding part of the S-valve is: FKM \*: Produced by Mitsubishi Cable Industries, Ltd.

### 2. Flange type

#### XMD

Symbol	Type	Applicable flange size
Nil	KF (NW)	25, 40, 50, 63, 80
D	K (DN)	63, 80
C	CF	40 (070), 63 (114)

#### XYD

Nil	KF (NW)	25, 40, 50, 63, 80
D	K (DN)	63, 80

#### XYD

Symbol	Pilot port direction
Nil	Rear flange surface
K	Left flange surface
M	Right flange surface

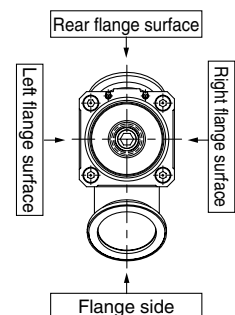

### 5. Auto switch type

Symbol	Auto switch	Remarks
Nil	—	Without auto switch (without built-in magnet)
M9N (L)	D-M9N (L)	Solid state switch
M9P (L)	D-M9P (L)	
M9B (L)	D-M9B (L)	
A90 (L)	D-A90 (L)	Reed switch (Flange size 16 is not available.)
A93 (L)	D-A93 (L)	
M9//	—	Without auto switch (with built-in magnet)

Auto switches cannot be mounted in the case of high temperature types (temperature specifications H0). The standard lead wire length is 0.5m. For 3m, "L" is added at the end of the part number. Ex.) -M9NL

### Part numbers indicating changed seal material and leakage

Symbol	Changed part <sup>Note 2)</sup>	Leakage Pa m <sup>3</sup> /s or less <sup>Note 1)</sup>	
		Internal	External
Nil	—	1.3 x 10 <sup>-10</sup> (FKM)	1.3 x 10 <sup>-11</sup> (FKM)
A	2, 3, 4, 5	1.3 x 10 <sup>-8</sup>	1.3 x 10 <sup>-9</sup>
B	2, 4, 5	1.3 x 10 <sup>-8</sup>	1.3 x 10 <sup>-11</sup> (FKM)
C	3	1.3 x 10 <sup>-10</sup> (FKM)	1.3 x 10 <sup>-9</sup>

Note 1) Values at ambient temperatures, excluding gas permeation.

Note 2) Refer to parts number of "Construction" on the page 9 for changed part. Number indicates parts number of "Construction" accordingly.

To order something else "Nil" (standard), list the symbols starting with "X", followed by each symbol for "seal material" and then "changed parts" at last.

Ex.) XMD-25-M9NA-XN1A

# Series XMD, XYD

## Specifications

Model	XMD-25 XYD-25	XMD-40 XYD-40	XMD-50 XYD-50	XMD-63 XYD-63	XMD-80 XYD-80	
Flange (valve) size	25	40, CF070	50	63, CF114	80	
Valve type	Normally closed (Pressurize to open, spring seal) [both main & initial exhaust valves]					
Fluid	Inactive gas under vacuum					
Operating temperature °C	5 to 60 (High temperature type: 5 to 150)					
Operating pressure Pa	Atmospheric pressure to $1 \times 10^{-6}$					
Conductance $\ell/s$ <small>Note 1)</small>	Main exhaust valve	14	45	80	160	200
	Initial exhaust valve	0.5 to 3	2 to 8	2.5 to 11	4 to 18	4 to 18
Leakage $\text{Pa}\cdot\text{m}^3/\text{s}$	Internal	$1.3 \times 10^{-10}\{1 \times 10^{-10}\}$ at ambient temperatures, excluding gas permeation				
	External	$1.3 \times 10^{-11}\{1 \times 10^{-11}\}$ at ambient temperatures, excluding gas permeation				
Operating time s	Main exhaust valve	0.10	0.21	0.24	0.26	0.28
	Initial exhaust valve	0.07	0.08	0.09	0.23	0.27
Flange type	KF (NW)	KF (NW), CF	KF (NW)	KF (NW), K (DN), CF	KF (NW), K (DN)	
Principle materials	Body: SCS13 (Conforms to Stainless steel SUS304) Bellows: Stainless steel SUS316L Bellows holder: Stainless steel SUS304. FKM (Standard seal material)					
Pilot pressure MPa	0.4 to 0.7 [both main and initial exhaust valves]					
Pilot port size	M5	Rc 1/8				
Service life (million cycles)	200 (FKM seal material)					
Weight kg <small>Note 2)</small>	XMD	0.65	1.50 (1.86)	2.20	4.10 (5.46)	6.80
	XYD	0.71	1.52	2.60	4.80	8.30

Note 1) Main exhaust valve conductance is the value for the molecular flow of an elbow having the same dimensions. The initial exhaust valve is the value for the viscous flow.

Note 2) Figures in ( ) indicates the weight of CF, conflate fittings.



## Construction

### XMD/Angle type

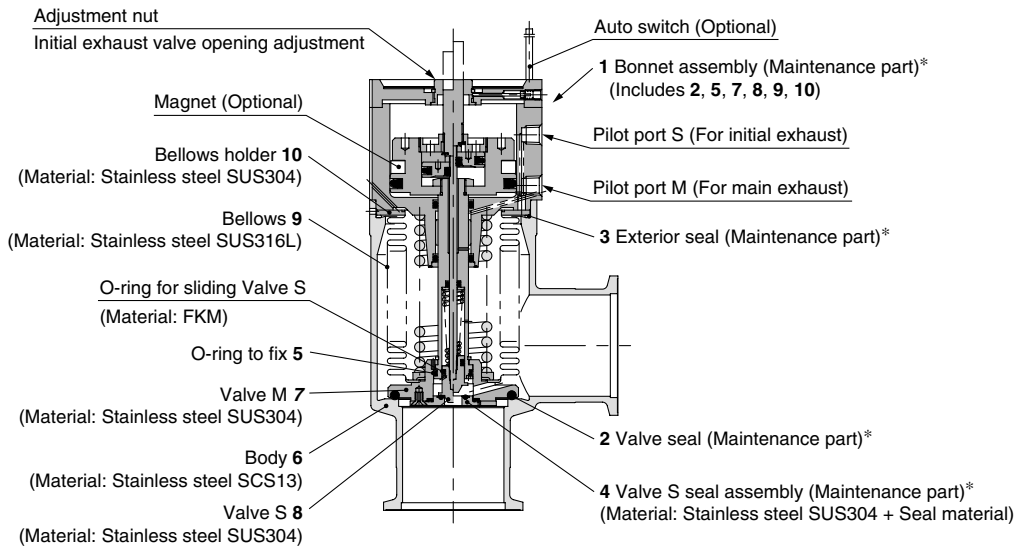

### XYD/In-line type

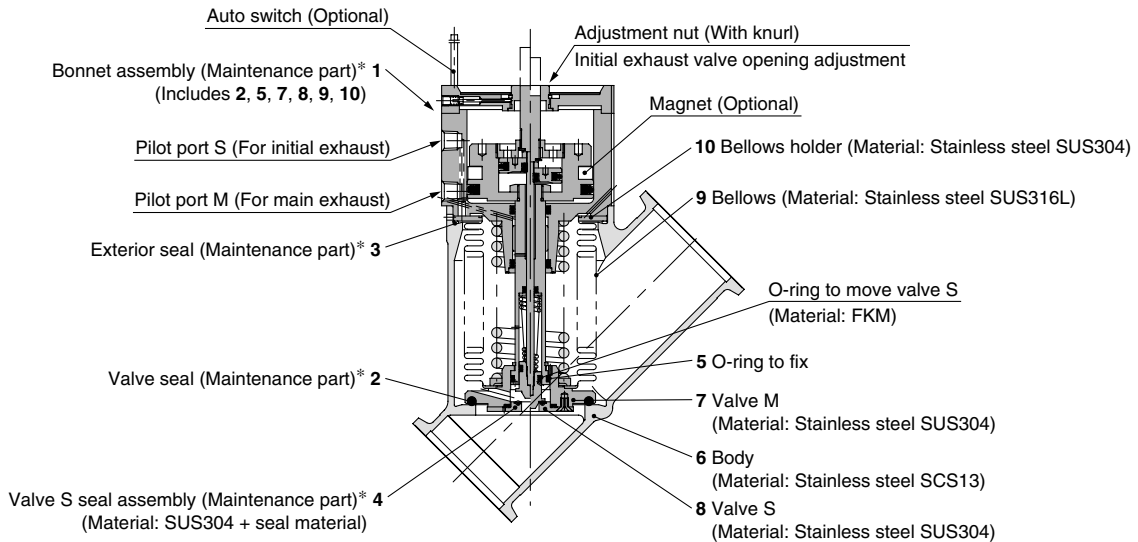

\* Refer to the page 22 for maintenance parts.

### <Operating principle> Series XMD, XYD

#### [1] Initial exhaust valve opening adjustment

The initial exhaust rate should be adjusted before operation (with pilot port S in an unpressurized state).

The initial exhaust rate is set to zero by turning the adjustment nut clockwise until it just stops. (Do not use a tool.)

The initial exhaust rate is adjusted by turning the nut anti-clockwise. The number of adjustment nut (its pitch is 1mm) rotations and initial exhaust conductance should be confirmed referring to the figure on the right.

#### [2] Opening of the initial exhaust valve (valve S)

When pressure is applied to the pilot port S, the valve S is removed from the valve S assembly and opens until the adjusted opening setting.

#### [3] Opening of the main exhaust valve (valve M)

When pressure is applied to the pilot port M, the valve M is removed from the body seat surface and fully opens.

#### [4] Closing of the initial exhaust valve, the main exhaust valve

By removing the pressure from the pilot ports S and M, both valves return to their sealed position.

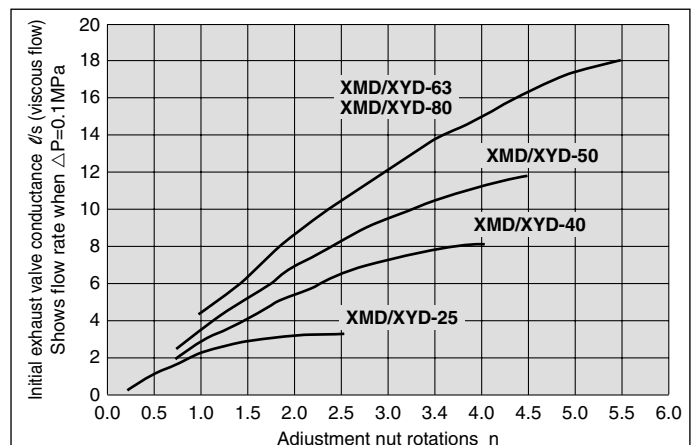

# Series XMD, XYD

## Dimensions

### XMD/Angle type

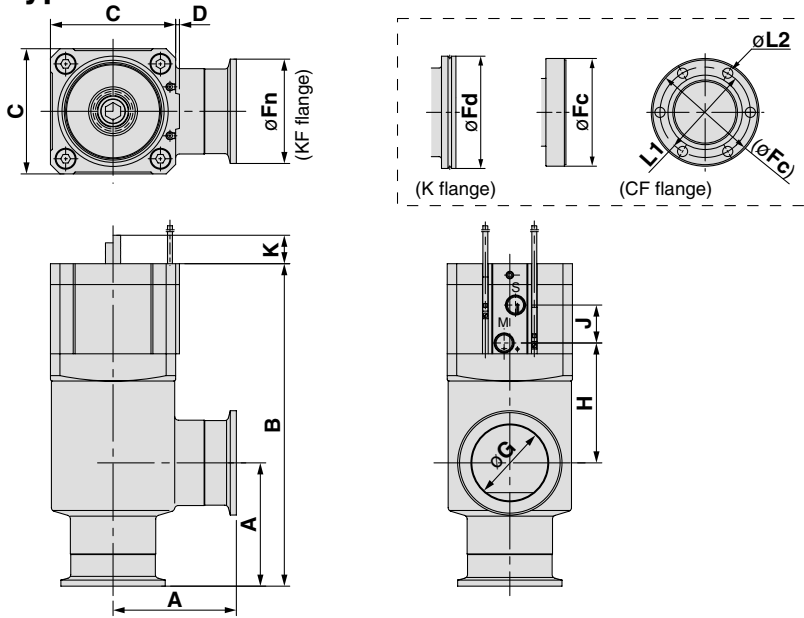

Model	A	B	C	D	F <sub>n</sub>	F <sub>d</sub>	F <sub>c</sub>	G	H	J	K	P.C.D L1	L2
XMD-25	50	123	48	1	40	—	—	26	41	16	7.5	—	—
XMD-40	65	170	66	2	55	—	70	41	63	20	15	P.C.D 58.7	6- $\phi$ 6.6
XMD-50	70	183	79	2	75	—	—	52	68	20	17.5	—	—
XMD-63	88	217	100	3	87	95	114	70	72	20	19.5	P.C.D 92.1	8- $\phi$ 8.4
XMD-80	90	256	117	3	114	110	—	83	98	20	26.5	—	—

### XYD/In-line type

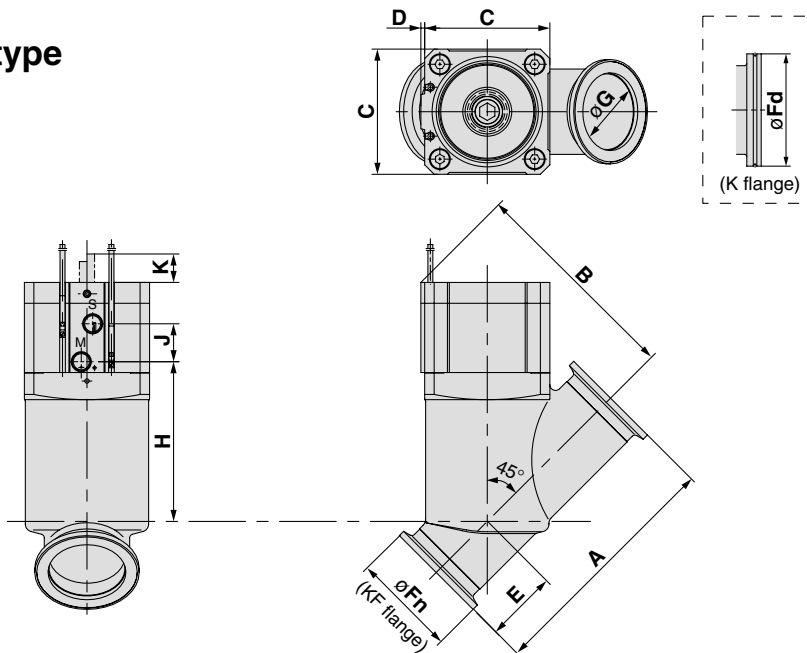

Model	A	B	C	D	E	F <sub>n</sub>	F <sub>d</sub>	G	H	J	K
XYD-25	100.2	86.7	48	1	23.5	40	—	26	66	16	7.5
XYD-40	130	114	66	2	38	55	—	41	84	20	15
XYD-50	178	128	79	2	53	75	—	52	95	20	17.5
XYD-63	209	163	100	3	61	87	95	70	121	20	19.5
XYD-80	268	193	117	3	80	114	110	83	144	20	26.5

Stainless steel  
High Vacuum Angle/In-line Valve

# Series XMH, XYH

## Manual Valve/Bellows Seal



### How to Order

Angle type

**XMH** — **16** □ — □ — □

In-line type

**XYH** — **25** □ — □ — □

1 2 3



### 1. Flange size

Size	XMH	XYH
16	∨	—
25	∨	∨
40	∨	∨
50	∨	∨

### 2. Flange type

#### XMH

Symbol	Type	Applicable flange size
Nil	KF (NW)	16, 25, 40, 50
C	CF	16 (034), 40 (070)

#### XYH

Nil	KF (NW)	25, 40, 50
-----	---------	------------

### 3. Seal material and its changed part

#### • Seal material

Symbol	Seal material	Compound No.
Nil	FKM	1349-80*
N1	EPDM	2101-80*
P1	BARREL PERFLUORO®	70W
Q1	Kalrez®	4079
R1	CHEMRAZ®	SS592
R2		SS630
R3		SSE38
S1	VMQ	1232-70*
T1	FKM for Plasma	3310-75*
U1	ULTIC ARMOR®	UA4640

\*: Produced by Mitsubishi Cable Industries, Ltd.

#### • Part numbers indicating changed seal material and leakage

Symbol	Changed part <sup>Note 2)</sup>	Leakage Pa m <sup>3</sup> /s or less <sup>Note 1)</sup>	
		Internal	External
Nil	—	1.3 x 10 <sup>-10</sup> (FKM)	1.3 x 10 <sup>-11</sup> (FKM)
A	2, 3	1.3 x 10 <sup>-8</sup>	1.3 x 10 <sup>-9</sup>
B	2	1.3 x 10 <sup>-8</sup>	1.3 x 10 <sup>-11</sup> (FKM)
C	3	1.3 x 10 <sup>-10</sup> (FKM)	1.3 x 10 <sup>-9</sup>

Note 1) Values at ambient temperatures, excluding gas permeation.

Note 2) Refer to parts number of "Construction" on the page 12 for changed part. Number indicates parts number of "Construction" accordingly.

To order something else "Nil" (standard), list the symbols starting with "X", followed by each symbol for "seal material" and then "changed parts" at last.

Ex.) XMH-16-XN1A

# Series XMH, XYH

## Specifications

Model		XMH-16	XMH-25 XYH-25	XMH-40 XYH-40	XMH-50 XYH-50
Flange (valve) size		16, CF034	25	40, CF070	50
Valve type		Manual type			
Fluid		Inactive gas under vacuum			
Operating temperature °C		5 to 150			
Operating pressure Pa		Atmospheric pressure to $1 \times 10^{-6}$			
Conductance $\ell/s$ <sup>Note 1)</sup>		5	14	45	80
Leakage $\text{Pa}\cdot\text{m}^3/\text{s}$	Internal	$1.3 \times 10^{-10}\{1 \times 10^{-10}\}$ at ambient temperature, excluding gas permeation			
	External	$1.3 \times 10^{-11}\{1 \times 10^{-11}\}$ at ambient temperature, excluding gas permeation			
Flange type		KF (NW), CF	KF (NW)	KF (NW), CF	KF (NW)
Principle materials		Body: SCS13 (Conforms to Stainless steel SUS304) Bellows: Stainless steel SUS316L Bellows holder: Stainless steel SUS304. FKM (Standard seal material)			
Pilot torque N·m		0.1 %	0.15 %	0.35 %	0.5 %
Handle revolutions		5	7	10	13
Service life (million cycles)		10			
Weight kg <sup>Note 2)</sup>	XMH	0.31 (0.35)	0.57	1.35 (1.71)	2.02
	XYH	—	0.62	1.37	2.42

Note 1) Conductance is the value for the molecular flow of an elbow having the same dimensions.

Note 2) Figures in ( ) indicates the weight of CF, conflate fittings.

## Construction

### XMH/Angle type

### XYH/In-line type

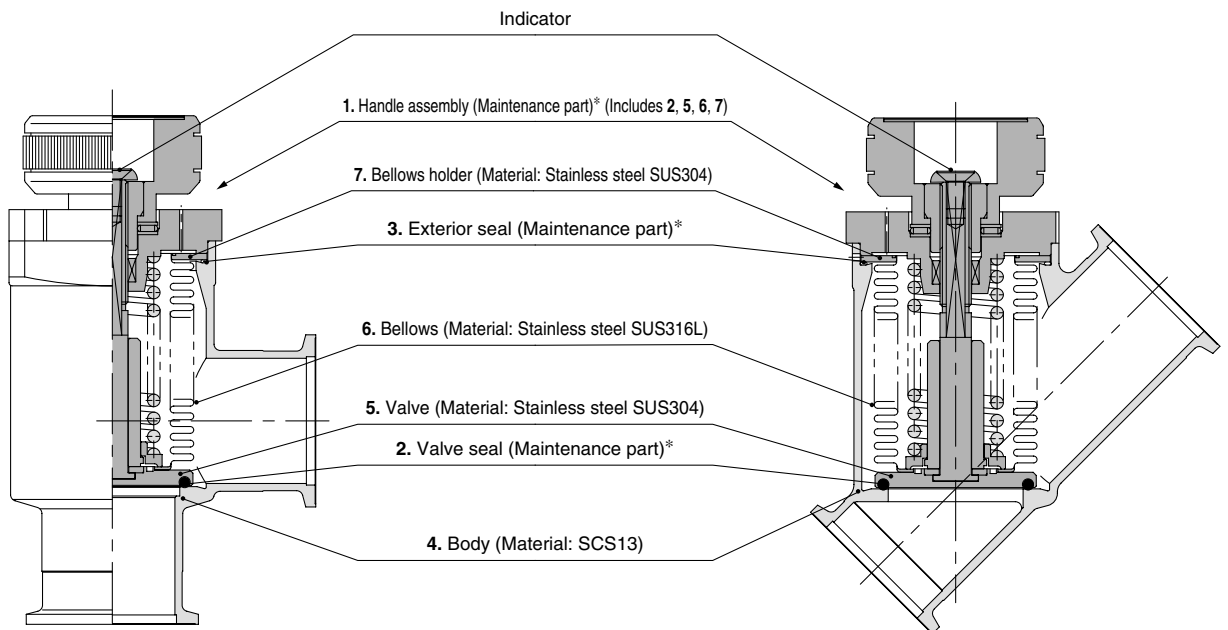

\* Refer to the page 22 for the maintenance parts.

## Dimensions

### XMH/Angle type

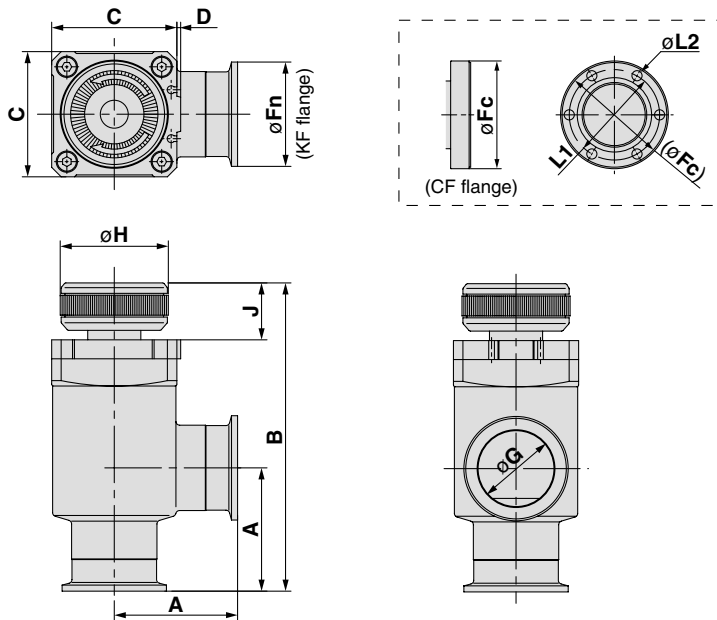

Model	A	B	C	D	Fn	Fc	G	H	J	P.C.D L1	L2
<b>XMH-16</b>	40	100.5	38	1	30	34	17	35	18	P.C.D 27	6- $\phi$ 4.4
<b>XMH-25</b>	50	114	48	1	40	—	26	40.5	21.5	—	—
<b>XMH-40</b>	65	162.5	66	2	55	70	41	57	30	P.C.D 58.7	6- $\phi$ 6.6
<b>XMH-50</b>	70	179.5	79	2	75	—	52	70	35	—	—

### XYH/In-line type

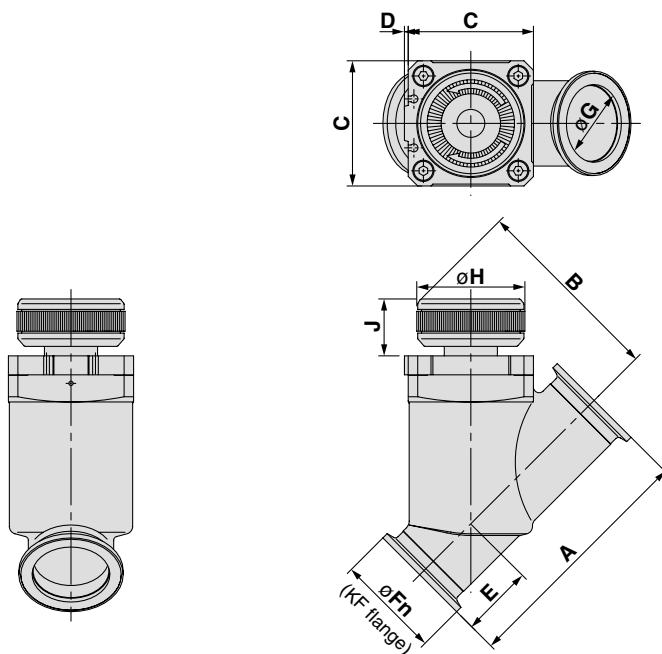

Model	A	B	C	D	E	Fn	G	H	J
<b>XYH-25</b>	100.2	75.8	48	1	23.5	40	26	40.5	21.5
<b>XYH-40</b>	130	102.5	66	2	38	55	41	57	30
<b>XYH-50</b>	178	119	79	2	53	75	52	70	35

# Series XM, XY

# Auto Switch Specifications

## Auto Switches Common Specifications

Auto switch type	Reed switch	Solid state switch
Leakage current	—	3-wire: 100μA or less, 2-wire: 0.8mA or less
Operating time	1.2ms	1ms or less
Impact resistance	300m/s <sup>2</sup>	1000m/s <sup>2</sup>
Insulation resistance	50MΩ or more at 500V DC (between lead wire and case)	
Withstand voltage	1500V AC/min. (between lead wire and the case)	1000V AC/min. (between lead wire and the case)
Ambient temperature	-10 to 60°C	
Enclosure	IEC529 standard IP67, JIS C 0920 watertight construction	

## Lead Wire Length

How to Order

Ex.)

D-M9P **L**

Lead wire length

Nil	0.5m
L	3m

## Contact Protection Box/CD-P11, CD-P12

### <Applicable switch type>

Auto switch types,

D-A9□ and A9□V are not incorporated with the contact protection circuit.

1. In the case operation load is an inductive load.
2. In the case the wiring length to load is more than 5m.
3. In the case the load voltage is 100 or 200V AC.

Be sure to use the contact protection box in any case mentioned above.  
Otherwise, the contact life may be shortened. (Due to permanent energizing conditions.)

### Specifications

Model number	CD-P11		CD-P12
Load voltage	100V AC	200V AC	24V DC
Max. load current	25mA	12.5mA	50mA

\* Lead wire length — Switch connection side 0.5m  
Load connecting side 0.5m



### Internal circuit

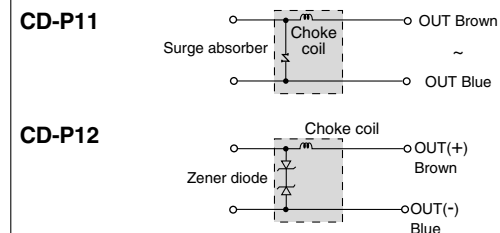

### Dimensions

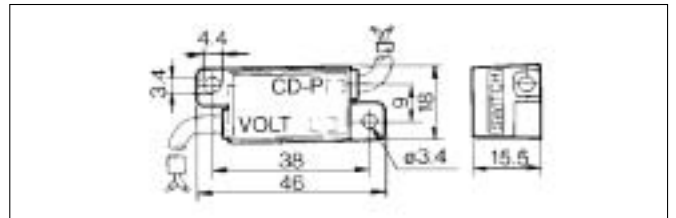

## Contact Protection Box/Connection Method

For connection of the switch body and the contact protection box, connect the lead wire in the side indicated as "SWITCH" on the contact protection box to the lead wire from the switch body. The length of lead wire between the switch body and the contact protection box should be within 1m and they should be set as close together as possible.

# Prior to Use

## Auto Switches/Connections and Examples

### Basic Wiring

#### Solid state 3-wire NPN

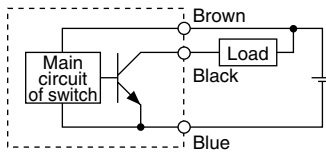

#### Solid state 3-wire PNP

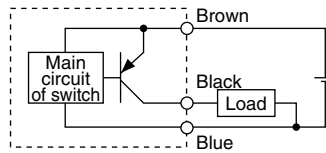

#### 2-wire

##### <Solid state switch>

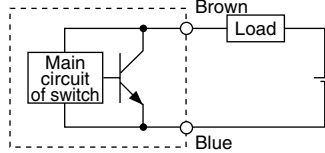

#### 2-wire

##### <Reed switch>

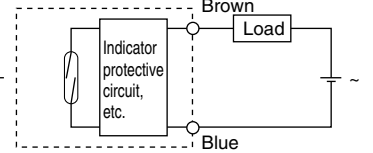

(Power supplies for switch and load separate.)

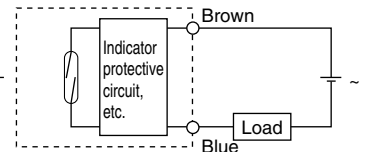
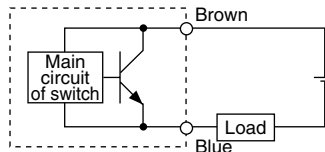
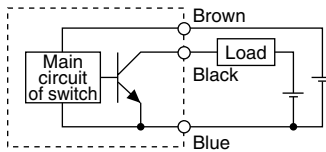

### Examples of Connection to PLC (Programmable Logic Controller)

#### •Sink input 3-wire NPN

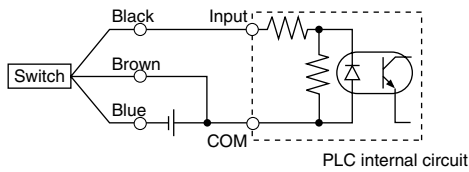

#### •Source input 3-wire PNP

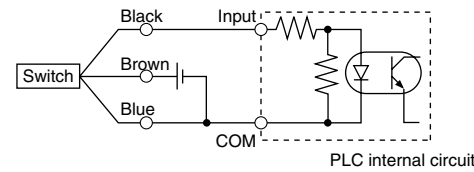

Connect according to the PLC input specifications. Please note, the connection method varies dependant on PLC specification.

#### 2-wire

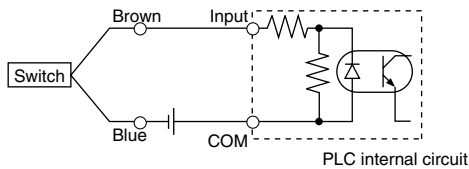

#### 2-wire

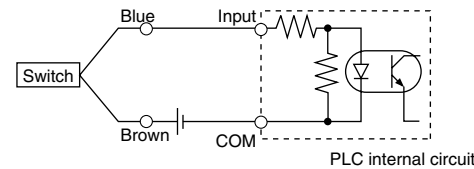

### Connection Examples for AND (Series) and OR (Parallel)

#### •3-wire

##### NPN/AND connection (with relay)

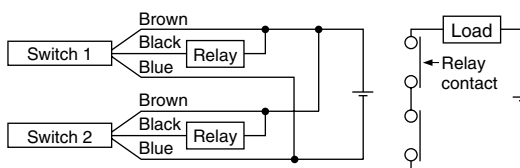

##### NPN/AND connection (with switch)

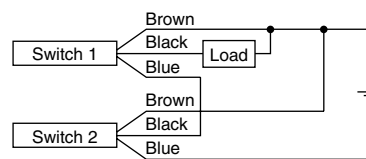

##### NPN/OR connection

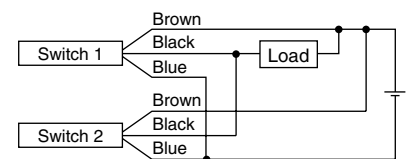

Indication lights up when both switches are ON.

#### •2-wire (2 pcs.)

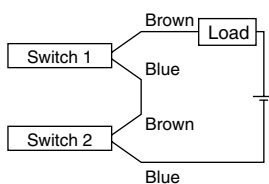

When 2 switches are connected by AND, load voltage will decrease at ON and these connections may cause malfunction of load. Indication lights up when both switches are ON.

#### OR connection

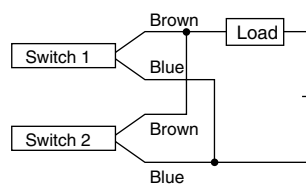

##### [Solid state switch]

When 2 switches are connected by OR, load voltage will increase at OFF and these connections may cause malfunction.

##### [Reed switch]

There is no current leakage so that load voltage does not increase at OFF. The flowing current is broken up into the ON state switches, so indicator light becomes dark or may not turn ON due to the lack of the current.

$$\begin{aligned} \text{Load voltage at ON} &= \text{Supply voltage} - \text{Residual voltage} \times 2 \text{ pcs.} \\ &= 24\text{V} - 4\text{V} \times 2 \text{ pcs.} \\ &= 16\text{V} \end{aligned}$$

Example) Supply voltage 24V DC, switch internal drop voltage 4V

$$\begin{aligned} \text{Load voltage at OFF} &= \text{Leakage current} \times 2 \text{ pcs.} \times \text{Load impedance} \\ &= 1\text{mA} \times 2 \text{ pcs.} \times 3\text{k}\Omega \\ &= 6\text{V} \end{aligned}$$

Example) Load impedance 3kΩ, switch leakage current 1mA

# Solid State Switch/Direct Mounting D-M9N, D-M9P, D-M9B



## Grommet

- Reduced load currents for 2-wire model (2.5 to 40 mA)
- Compliance with lead-free requirements
- Use of UL-approved lead wires (style 2844)



## Caution

### Precautions

Care should be taken when stripping the outer cable covering as the insulator may be accidentally torn or damaged if incorrectly stripped, as shown below.

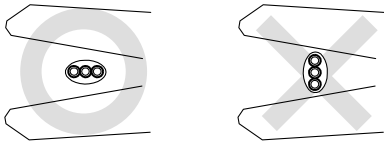

## Auto Switch Internal Circuit

### D-M9N

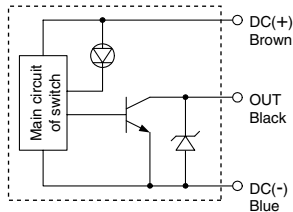

### D-M9P

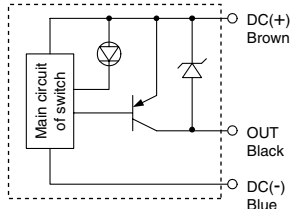

### D-M9B

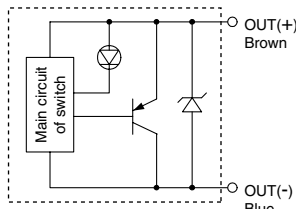

## Auto Switch Specifications

PLC: Programmable Logic Controller

D-M9□ (With indicator light)			
Model number	D-M9N	D-M9P	D-M9B
Wiring	3-wire		2-wire
Output	NPN	PNP	—
Applicable load	IC circuit, Relay, PLC		24V DC releay, PLC
Power voltage	5, 12, 24V DC (4.5 to 28V)		—
Current consumption	10mA or less		—
Load voltage	28V DC or less	—	24V DC (10 to 28V DC)
Load current	40mA or less		2.5 to 40mA
Internal voltage drop	0.8V or less		4V or less
Current leakage	≤ 100μA at 24V DC		0.8mA or less
Indicator light	Red LED lights when ON.		

- Lead wire — Oil-proof heavy-duty vinyl cable  
2.7 x 3.2 with elliptic cross-section, 0.15mm<sup>2</sup>, 2 cores (D-M9B), or 3 cores (D-M9N, D-M9P)

Note 1) Refer to common specifications on page 16.

Note 2) Refer to the page 16 for lead wire length.

## Auto Switch Weight

Unit: g

Model		D-M9N	D-M9P	D-M9B
Lead wire length m	0.5	8	8	7
	3	41	41	38

## Auto Switch Dimensions

### D-M9□ D-M9B, N, P

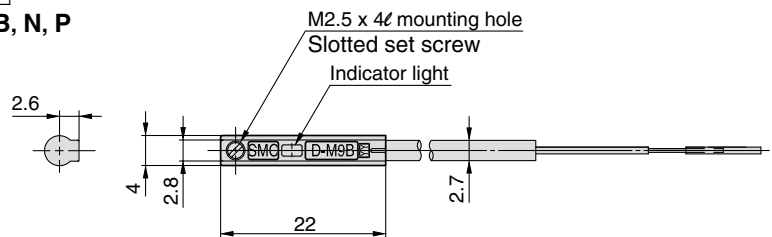

### D-M9N, P (3-wire)

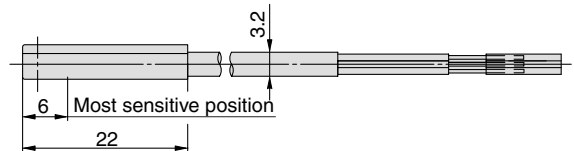

### D-M9B (2-wire)

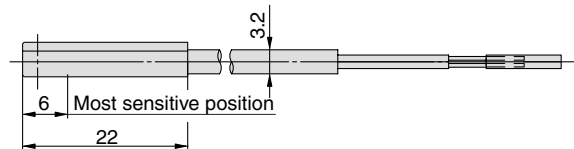



# Reed Switch/Direct Mounting D-A90, D-A93



**Grommet  
Electrical entry: In-line**



## ⚠ Caution

### Precautions

1. Fix the switch with appropriate screw installed on the auto switch body. If using other screws, switch may be damaged.

## Auto Switch Internal Circuit

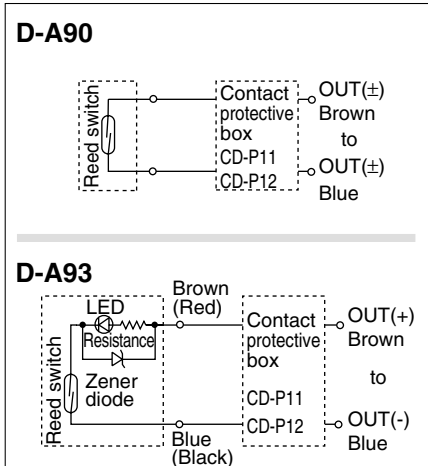

- Note) 1. In the case operation load is an inductive load.  
 2. In the case the wiring length to load is more than 5m.  
 3. In the case the load voltage is 100V AC.  
 Be sure to use the contact protection box in any case mentioned above not to shorten the contact life. Refer to the page 16 for details of the contact protection box.

## Auto Switch Specifications

PLC: Programmable Logic Controller

D-A90 (Without indicator light)			
Model number	D-A90		
Applicable load	IC circuit, Relay, PLC		
Load voltage	24V <sup>AC</sup> / <sub>DC</sub> or less	48V <sup>AC</sup> / <sub>DC</sub> or less	100V <sup>AC</sup> / <sub>DC</sub> or less
Max. load current	50mA	40mA	20mA
Contact protection circuit	—		
Internal resistance	1Ω or less (Including 3m lead wire)		
D-A93 (With indicator light)			
Model number	D-A93		
Applicable load	Relay, PLC		
Load voltage	24V DC	100V AC	
Max. load current and load current range	5 to 40mA	5 to 20mA	
Contact protection circuit	—		
Internal voltage drop	D-A93 2.4V or less (up to 20mA)/3V or less (up to 40mA)		
Indicator light	Red LED lights when ON.		

- Lead wire  
 D-A90/D-A93 — Oil-proof heavy-duty vinyl cable,  $\phi 2.7$ , 0.18mm<sup>2</sup> x 2 cores (Brown, Blue), 0.5m  
 Note 1) Refer to common specifications on page16.  
 Note 2) Refer to page 16 for lead wire length.

## Auto Switch Weight

Model	D-A90	D-A93
Lead wire length 0.5m	6	6
Lead wire length 3m	30	30

## Auto Switch Dimensions

### D-A90, D-A93

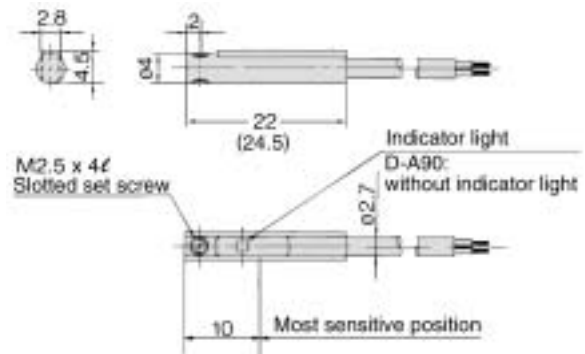

( ) : D-A93