

# Vacuum Pad

ø1.5, ø2, ø3.5, ø4, ø6, ø8, ø10, ø13, ø16

New

RoHS

Overall length is shortened. In the case of Flat type (Pad diameter: ø2)

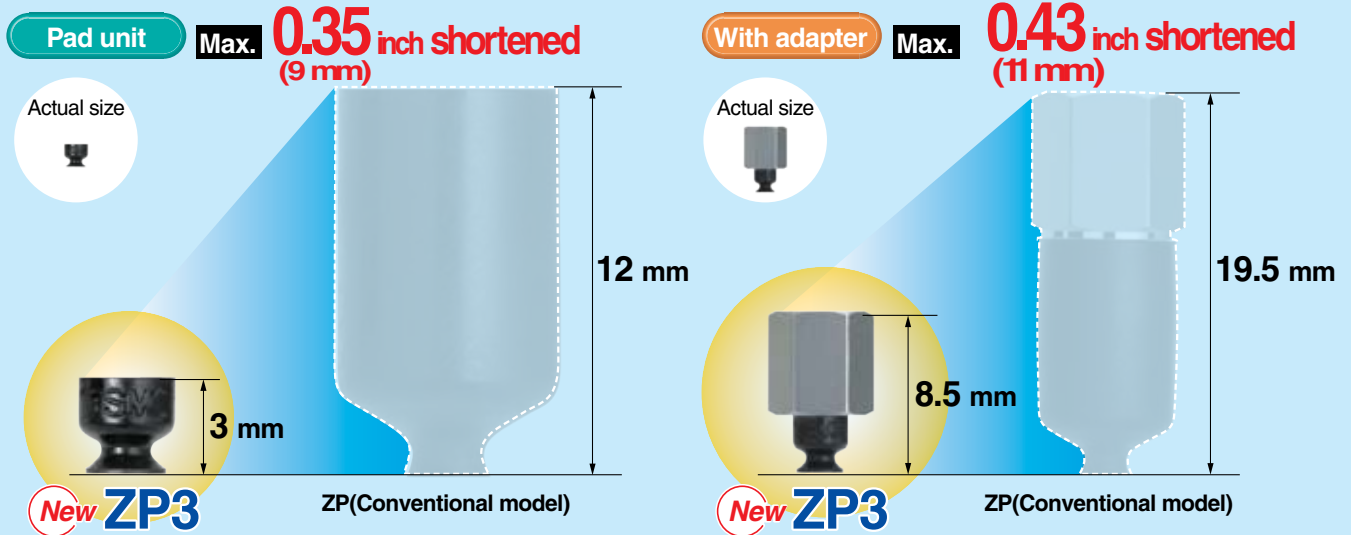

Space-saving ø2 piping reduces working space!

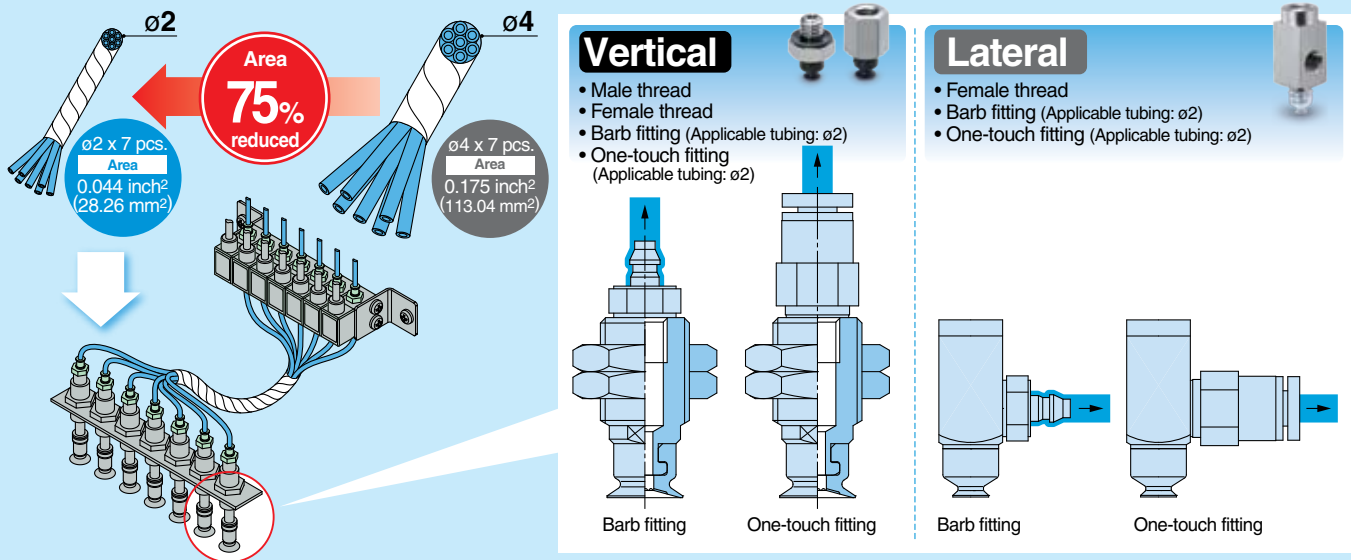

Variations Pad diameter ø1.5 added!

Type	Pad diameter									
	ø1.5	ø2	ø3.5	ø4	ø6	ø8	ø10	ø13	ø16	
Flat	New									
Flat with groove										
Bellows										



Series ZP3

SMC  
CAT.NAS100-100A

## Excellent functions New

### Excellent functions

Adsorption surface is shot-blasted  
Micro-dents and bumps on the surface facilitate easy removal.

With groove

Less contact surface with the workpiece makes it easy to remove.



### Construction to prevent pad from coming off

New shape for connecting with the adapter prevents the pad from coming off.

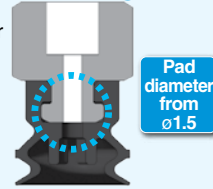

### Easier identification

SMC logo mark



### Fixing boss allows easy mounting and repeatability.

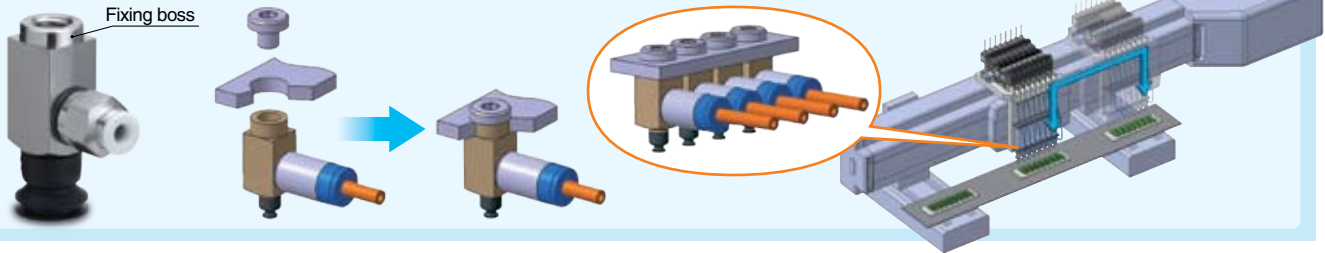

## Compact buffer body New

### Overall length is shortened.

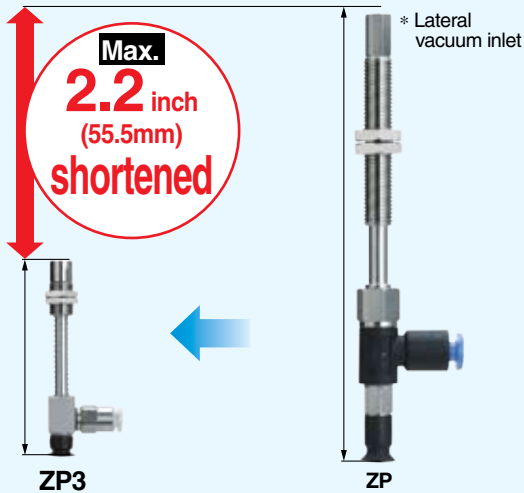

Pad diameter ø8, Flat, With one-touch fitting

**ZP3**

Stroke	Overall length (mm)
3	40
6	46
10	56
15	59
20	66.5
25	—

**ZP**

Stroke	Overall length (mm)
3	—
6	78.5
10	109.5
15	114.5
20	—
25	124.5

### Short stroke type: 3 mm added

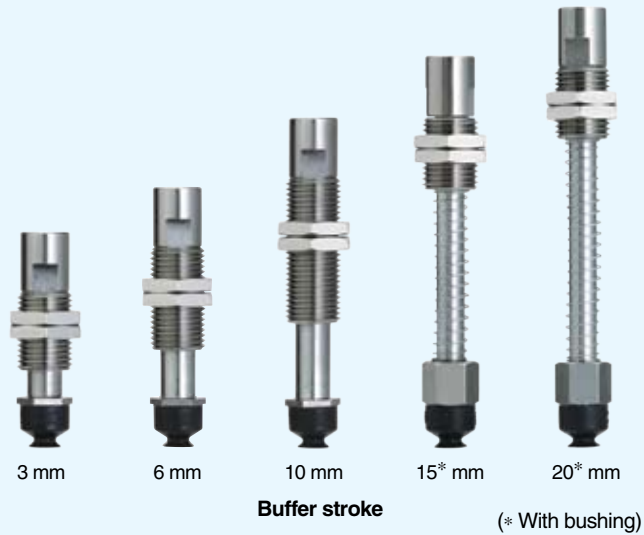

Pad diameter	Buffer specifications	Stroke (mm)				
		3	6	10	15	20
ø1.5, ø2, ø3.5	Rotating, Non-rotating	●	●	—	—	—
	Rotating	●	●	●	—	—
	Rotating, With bushing	—	—	—	●	●
ø4, ø6, ø8 ø10, ø13, ø16	Rotating	●	●	●	●	●
	Non-rotating	●	●	●	●	●

## Wide selection of piping

Male thread

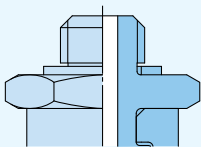

Female thread

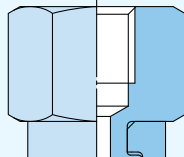

Barb fitting

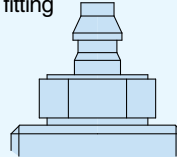

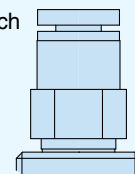

One-touch fitting



New For ø2 piping!

# Series Variations

Type	Pad diameter										Material	Page
	ø1.5	ø2	ø3.5	ø4	ø6	ø8	ø10	ø13	ø16			
 <p><b>Flat</b> For adsorption of general workpieces For adsorption of work pieces with flat and not deformed surface</p>	●	●	●								NBR Silicone rubber Urethane rubber FKM Conductive NBR Conductive silicone rubber	P.1
 <p><b>Flat with groove</b> For a workpiece which is likely to deform For releasing a workpiece certainly</p>				●	●	●	●	●	●			
 <p><b>Bellows</b> For adsorption of work pieces with inclined surface</p>				●	●	●	●	●	●			

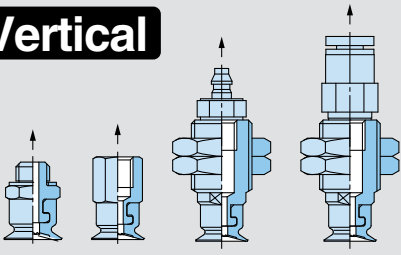
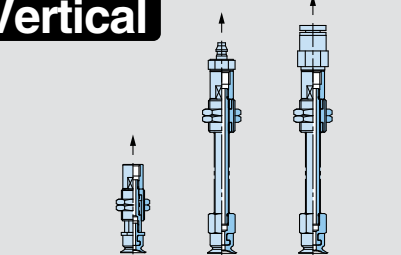
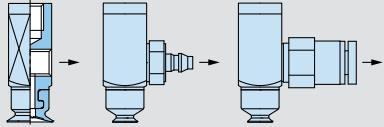
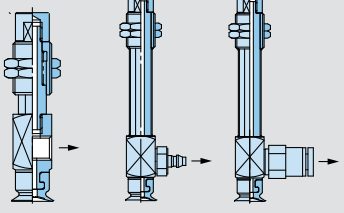
Vacuum inlet direction	Buffer attachment	Vacuum inlet		Page
<p><b>Vertical</b></p>  <p>ZP3-T <input type="checkbox"/> <input type="checkbox"/> <input type="checkbox"/> - <input type="checkbox"/></p>	Without buffer (with adapter)	Male thread	M3, M5	P.3
		Female thread	M3, M5	
		Barb fitting	Polyurethane tubing ø2 Soft nylon/ Polyurethane tubing ø4, ø6	
		One-touch fitting	ø2, ø4, ø6	
<p><b>Vertical</b></p>  <p>ZP3-T <input type="checkbox"/> <input type="checkbox"/> <input type="checkbox"/> - <input type="checkbox"/> <sup>J</sup>/<sub>JB</sub> <input type="checkbox"/> - <input type="checkbox"/></p>	Stroke with buffer 3 mm 6 mm 10 mm 15 mm 20 mm	Female thread	M3, M5	P.15
		Barb fitting	Polyurethane tubing ø2 Soft nylon/ Polyurethane tubing ø4, ø6	
		One-touch fitting	ø2, ø4, ø6	
<p><b>Lateral</b></p>  <p>ZP3-Y <input type="checkbox"/> <input type="checkbox"/> <input type="checkbox"/> - <input type="checkbox"/> - <input type="checkbox"/></p>	Without buffer (with adapter)	Female thread	M3, M5	P.25
		Barb fitting	Polyurethane tubing ø2 Soft nylon/ Polyurethane tubing ø4, ø6	
		One-touch fitting	ø2, ø4, ø6	
<p><b>Lateral</b></p>  <p>ZP3-Y <input type="checkbox"/> <input type="checkbox"/> <input type="checkbox"/> - <input type="checkbox"/> <sup>J</sup>/<sub>JB</sub> <input type="checkbox"/> - <input type="checkbox"/></p>	Stroke with buffer 3 mm 6 mm 10 mm 15 mm 20 mm	Female thread	M3, M5	P.31
		Barb fitting	Polyurethane tubing ø2 Soft nylon/ Polyurethane tubing ø4, ø6	
		One-touch fitting	ø2, ø4, ø6	

Construction ..... P.41  
 Adapter Applicable Pad List ..... P.42  
 Buffer Applicable Pad List ..... P.43

Mounting Adapter Part No. .... P.47  
 Buffer Assembly Part No. .... P.49



# Vacuum Pads Series ZP3/ZP2/ZP

## Pad Diameter List

★: **New** Series ZP3    ●: Series ZP2    ○: Series ZP

Pad type	Symbol	Diameter (mm)																
		0.8	1.1	1.5	2	3	3.5	4	5	6	7	8	9	10	11	13	14	15
Flat	U	—	—	★	★	●	○	○	—	○	—	○	—	○	—	○	—	—
	MU	—	—	—	○	—	○	○	○	○	—	○	—	○	—	—	—	○
	EU	—	—	—	○	—	○	—	○	—	○	—	—	—	—	—	—	○
	AU	—	—	—	○	○	—	○	—	○	—	○	—	—	—	—	—	—
Flat with rib	C	—	—	—	—	—	—	—	○	○	○	—	○	—	○	—	—	
Flat with groove	UM	—	—	—	—	—	★	—	★	—	★	—	★	—	★	—	—	
Thin flat	UT	—	—	—	—	—	—	○	○	—	—	—	○	○	○	○	—	
Thin flat with rib	CT	—	—	—	—	—	—	—	—	—	—	—	○	—	○	—	—	
Bellows	B	—	—	—	—	—	—	—	○	○	—	—	○	—	○	—	—	
	J	—	—	—	—	—	—	—	○	—	—	○	—	○	—	—	—	
	MB	—	—	—	—	—	○	—	○	—	○	—	○	—	—	—	○	
	ZJ	—	—	—	○	—	○	○	○	—	—	—	—	—	—	—	—	—
Deep	D	—	—	—	—	—	—	—	—	—	—	—	○	—	—	—	—	
Nozzle pad	AN	○	○	—	—	—	—	—	—	—	—	—	—	—	—	—	—	
Flat pad	MT	—	—	—	—	—	—	—	—	—	—	—	○	—	—	—	○	
Oval	W	—	—	—	—	—	○	○	○	○	—	—	○	—	—	—	—	
	U	—	—	—	○	—	○	○	—	—	—	—	—	—	—	—	—	—
Heavy-duty pad	Flat	H	—	—	—	—	—	—	—	—	—	—	—	—	—	—	—	—
	HT	—	—	—	—	—	—	—	—	—	—	—	—	—	—	—	—	—
	Bellows	HB	—	—	—	—	—	—	—	—	—	—	—	—	—	—	—	—
	Oval	HW	—	—	—	—	—	—	—	—	—	—	—	—	—	—	—	—
Mark-free pad	U	—	—	—	—	—	○	—	○	—	○	—	○	—	—	—	—	—
	H	—	—	—	—	—	—	—	—	—	—	—	—	—	—	—	—	—
Sponge pad	S	—	—	—	—	—	○	—	○	—	○	—	○	—	—	—	—	○
Resin attachment	K	—	—	—	—	—	—	—	○	—	○	—	○	—	○	—	—	—
Pad with ball spline buffer	U	—	—	—	○	—	○	—	○	—	○	—	—	—	—	—	—	—
Heavy-duty ball joint pad	H	—	—	—	—	—	—	—	—	—	—	—	—	—	—	—	—	—
	HB	—	—	—	—	—	—	—	—	—	—	—	—	—	—	—	—	—

\* Cyclone pad (Non-contact pad)

Made to Order

Note) The ZP2 series is blast type.

■ Products other than above  
Features 3

Vacuum pad for transferring disks  
ZP2 ES100-76

Vacuum pad for fixing panel  
ZP2 ES100-76

Vacuum saving valve  
ZP2 ES100-76

\* The ZP3 series is available from  $\phi 1.5$  to  $\phi 16$ . If you need other sizes or shapes, please choose from ZP or ZP2 series.

## Pad Diameter List













\* : Refer to SMC website in Best Pneumatics No. 4 for details of the ZP series.

SMC vacuum pad





Search 

<http://www.smcworld.com>

Catalogs

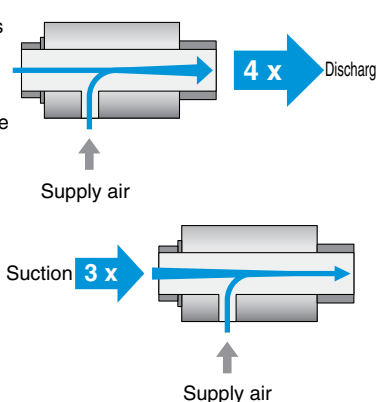
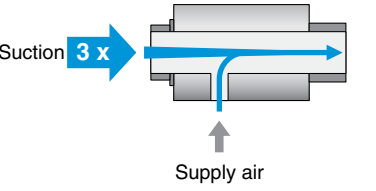
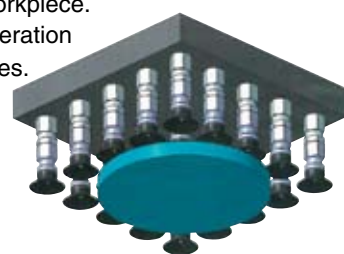
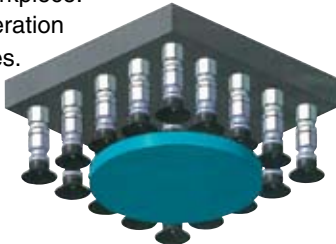
Pad diameter	Pad diameter																Symbol	Catalogs			
	16	18	20	25	30	32	40	46	50	63	80	100	125	150	250	300		340	ZP3 ES100-100	ZP2 ES100-76	Best Pneumatics
	○	—	○	○	—	○	○	—	○	—	—	—	—	—	—	—	—	U			
	—	—	—	—	—	—	—	—	—	—	—	—	—	—	—	—	—	MU	—		—
	—	—	—	—	—	—	—	—	—	—	—	—	—	—	—	—	—	EU			—
	—	—	—	—	—	—	—	—	—	—	—	—	—	—	—	—	—	AU	—		—
	○	—	○	○	—	○	○	—	○	—	—	—	—	—	—	—	—	C	—		—
	★	—	—	—	—	—	—	—	—	—	—	—	—	—	—	—	—	UM		—	—
	○	●	●	—	—	—	—	—	—	—	—	—	—	—	—	—	—	UT	—		—
	○	—	—	—	—	—	—	—	—	—	—	—	—	—	—	—	—	CT	—		
	○	—	○	○	—	○	○	—	○	—	—	—	—	—	—	—	—	B			—
	○	—	—	○	○	—	○	○	—	○	—	—	—	—	—	—	—	J	—		—
	●	—	—	●	●	—	—	—	—	—	—	—	—	—	—	—	—	MB	—		—
	—	—	●	—	—	—	—	—	—	—	—	—	—	—	—	—	—	ZJ	—		—
	—	—	—	—	—	—	●	●	—	—	—	—	—	—	—	—	—				—
	○	—	—	○	—	—	○	—	—	—	—	—	—	—	—	—	—	D	—		
	—	—	—	—	—	—	—	—	—	—	—	—	—	—	—	—	—	AN	—		—
	—	—	●	●	●	—	—	—	—	—	—	—	—	—	—	—	—	MT	—		—
	—	—	—	—	—	—	—	—	—	—	—	—	—	—	—	—	—	W	—		—
	—	—	—	—	—	—	—	—	—	—	—	—	—	—	—	—	—	U	—		—
	—	—	—	—	—	●	○	—	○	○	○	○	○	—	—	●	●	H	—		
	—	—	—	—	—	—	—	—	—	—	—	—	—	●	●	—	—	HT	—		—
	—	—	—	—	—	●	○	—	○	○	○	○	○	●	—	—	—	HB	—		—
	—	—	—	—	30 x 50	●	—	—	—	—	—	—	—	—	—	—	—	HW	—		—
	●	—	—	●	—	●	●	—	●	—	—	—	—	—	—	—	—	U	—		—
	—	—	—	—	—	—	●	—	●	●	●	●	●	—	—	—	—	H	—		—
	—	—	—	—	—	—	—	—	—	—	—	—	—	—	—	—	—	S	—		—
	●	—	●	●	—	●	—	—	—	—	—	—	—	—	—	—	—	K	—		—
	—	—	—	—	—	—	—	—	—	—	—	—	—	—	—	—	—	U	—		—
	—	—	—	—	—	—	●	—	●	●	●	●	●	—	—	—	—	H	—		—
	—	—	—	—	—	—	●	—	●	●	●	●	●	—	—	—	—	HB	—		—

# Related Products

Variations		Note
<p><b>Vacuum Flow ZH□-□-X185</b> <i>Made to Order</i></p> <ul style="list-style-type: none"> <li>■ A blow flow rate 4 times the supply air</li> <li>■ A vacuum flow rate 3 times the supply air</li> </ul> <p>A discharge flow rate 4 times the supply air can be generated. Contributes to reduction in flow consumption if discharge requires flow rate.</p>  <p>A suction flow rate 3 times the supply air can be generated. Contributes to reduction in flow consumption if suction requires flow rate.</p>		<p>—</p>
<p><b>Vacuum Saving Valve ZP2V</b></p> <ul style="list-style-type: none"> <li>■ Can restrict the reduction of vacuum pressure even when there is no workpiece.</li> <li>■ No need for switching operation when changing workpieces.</li> <li>■ Multiple vacuum pads can be operated by one ejector.</li> </ul> 		<p>Connection thread size for pad side</p> <ul style="list-style-type: none"> <li>• M5 x 0.8</li> <li>• M6 x 1</li> <li>• M8 x 1.25</li> <li>• R1/8</li> <li>• Rc1/8</li> <li>• G1/8</li> <li>• NPT1/8</li> </ul>
<p><b>Space Saving Vacuum Ejector/ Pump System ZQ</b></p> <ul style="list-style-type: none"> <li>■ Width: 10 mm Weight: 109 g</li> <li>(Single unit, with vacuum pressure switch and suction filter)</li> </ul>		<p>—</p>
<p><b>Multistage Ejector ZL</b></p> <ul style="list-style-type: none"> <li>■ Suction flow rate increased by a 3 stage diffuser construction.</li> <li>(Max. 200 L/min (ANR))</li> </ul>		<p>—</p>
<p><b>Air Suction Filter with One-touch Fittings/ In-line Type ZFC</b></p> <ul style="list-style-type: none"> <li>■ IN/OUT straight piping</li> <li>■ One-touch fittings for easy installation and remove</li> <li>■ Lightweight molded resin parts</li> <li>■ Cartridge type allows element replacement.</li> </ul>		<p>—</p>
<p><b>SMC Design Support Software Ver.2.0</b></p> <ul style="list-style-type: none"> <li>■ Model Selection Software</li> <li>■ Vacuum Adsorption Transfer System Selection Software</li> <li>■ Electric Actuator Selection Software</li> <li>■ SMC Draw Ver.1.0 Pneumatic Circuit Drawing Software</li> <li>■ Guide Cylinder Selection Software</li> <li>■ Energy Saving Software</li> </ul>		<p>—</p>

# Vacuum Equipment Model Selection

## CONTENTS

<b>1</b>	<b>Features and Precautions for Vacuum Adsorption</b>	<b>Front matter 2</b>
<b>2</b>	<b>Vacuum Pad Selection</b>	<b>Front matter 2</b>
	<ul style="list-style-type: none"><li>● Vacuum Pad Selection Procedures</li><li>● Points for Selecting Vacuum Pads<ul style="list-style-type: none"><li>A. Theoretical Lifting Force</li><li>B. Shear Force and Moment Applied to Vacuum Pad</li></ul></li><li>● Lifting Force and Vacuum Pad Diameter<ul style="list-style-type: none"><li>1. Theoretical Lifting Force</li></ul></li><li>● Vacuum Pad Type</li><li>● Vacuum Pad Material</li><li>● Rubber Material and Properties</li><li>● Color and Identification</li><li>● Buffer Attachment</li><li>● Pad Selection by Workpiece Type</li><li>● Vacuum Pad Durability</li></ul>	
<b>3</b>	<b>Selection of Vacuum Ejector and Vacuum Switching Valve</b>	<b>Front matter 8</b>
	<ul style="list-style-type: none"><li>● Calculating Vacuum Ejector and Switching Valve Size with the Formula</li></ul>	
<b>4</b>	<b>Leakage Volume during Workpiece Adsorption</b>	<b>Front matter 8</b>
	<ul style="list-style-type: none"><li>● Leakage Volume from Conductance of Workpiece</li><li>● Leakage Volume from Adsorption Test</li></ul>	
<b>5</b>	<b>Adsorption Response Time</b>	<b>Front matter 9</b>
	<ul style="list-style-type: none"><li>● Relationship between Vacuum Pressure and Response Time after Supply Valve (Switching Valve) is Operated</li><li>● Calculating Adsorption Response Time with the Formula</li><li>● Adsorption Response Time from the Selection Graph</li></ul>	
<b>6</b>	<b>Precautions on Vacuum Equipment Selection and SMC's Proposal</b>	<b>Front matter 11</b>
	<ul style="list-style-type: none"><li>● Safety Measures</li><li>● Precautions on Vacuum Equipment Selection</li><li>● Vacuum Ejector or Pump and Number of Vacuum Pads</li><li>● Vacuum Ejector Selection and Handling Precautions</li><li>● Supply Pressure of Vacuum Ejector</li><li>● Timing for Vacuum Generation and Suction Verification<ul style="list-style-type: none"><li>A. Timing for Vacuum Generation</li><li>B. Suction Verification</li><li>C. Set Pressure for Vacuum Pressure Switch</li></ul></li><li>● Dust Handling of Vacuum Equipment</li></ul>	
<b>7</b>	<b>Vacuum Equipment Selection Example</b>	<b>Front matter 15</b>
	<ul style="list-style-type: none"><li>● Transfer of Semiconductor Chips</li></ul>	
<b>8</b>	<b>Data</b>	<b>Front matter 16</b>
	<ul style="list-style-type: none"><li>● Selection Graph</li><li>● Glossary of Terms</li><li>● Countermeasures for Vacuum Adsorption System Problems (Troubleshooting)</li><li>● Non-conformance Examples</li><li>● Time of Replacement of Vacuum Pad</li></ul>	



# Model Selection

## 1 Features and Precautions for Vacuum Adsorption

Vacuum adsorption system as a method to hold a workpiece has the following features. But it is also necessary to note some precautions.

Features and precautions of vacuum

Features	<ul style="list-style-type: none"> <li>• Easy construction</li> <li>• Compatible with any place where adsorption is possible.</li> <li>• Compatible with soft and easily-deformed workpieces</li> <li>• Available when the space around the workpiece is limited.</li> </ul>
Precautions	<ul style="list-style-type: none"> <li>• Workpiece may drop under certain conditions since it is transferred being adsorbed.</li> <li>• Liquid or foreign matter around the workpiece may be sucked into the equipment.</li> <li>• Large adsorption area is necessary to get large gripping force.</li> <li>• Vacuum pad (rubber) may deteriorate.</li> <li>• Precise positioning is difficult.</li> </ul>

Fully understand the features above and select the equipment that suits your operating conditions.

## 2 Vacuum Pad Selection

### ● Vacuum Pad Selection Procedures

- 1) Fully taking into account the balance of a workpiece, identify the adsorption positioning, number of pads and applicable pad diameter (or pad area).
- 2) Find the theoretical lifting force from the identified adsorption area (pad area x number of pads) and vacuum pressure, and then find the lifting force considering actual lifting and safety factor of transfer condition.
- 3) Determine a pad diameter (or pad area) that is sufficient to ensure the lifting force is greater than the workpiece mass.
- 4) Determine the pad type and materials, and the necessity of buffer based on the operating environment, and the workpiece shape and materials.

The above shows selection procedures for general vacuum pads; thus, they will not be applicable for all pads. Customers are required to conduct a test on their own and to select applicable adsorption conditions and pads based on the test results.

### ● Points for Selecting Vacuum Pads

#### A. Theoretical Lifting Force

- The theoretical lifting force is determined by vacuum pressure and contact area of the vacuum pad.
- Since the theoretical lifting force is the value measured at the static state, the safety factor responding to the actual operating conditions must be estimated in the actual operation.
- It is not necessarily true that higher vacuum pressure is better. Extremely high vacuum pressure may cause problems.
  - When the vacuum pressure is unnecessarily high, pads are likely to be worn out quickly and cracked, which makes the pad service life shorter.
  - Doubling the vacuum pressure makes the theoretical lifting force double, while doubling the pad diameter makes the theoretical lifting force quadruple.
  - When the vacuum pressure (set pressure) is high, it makes not only response time longer, but also the necessary energy to generate a vacuum larger.

**Example) Theoretical lifting force = Pressure x Area** → 2 times

Pad diameter	Area (cm <sup>2</sup> )	Vacuum pressure [-40 kPa]	Vacuum pressure [-80 kPa]
ø6	0.28	<b>Theoretical lifting force</b> 1.1 N	Theoretical lifting force 2.2 N
ø16	2.01	<b>Theoretical lifting force</b> 8.0 N	Theoretical lifting force 16.1 N

↓ 4 times



## B. Shear Force and Moment Applied to Vacuum Pad

- Vacuum pads are not resistant to shear force (parallel force with adsorption surface) and moment.
- Minimize the moment applied to the vacuum pad with the position of the workpiece center of gravity in mind.
- The acceleration rate of the movement must be as small as possible, and make sure to take into consideration the wind pressure and impact. If measures to slow down the acceleration rate are introduced, safety to prevent the workpiece from dropping will improve.
- Avoid lifting the workpiece by adsorbing the vertical side with a vacuum pad (vertical lifting) if possible. When it is unavoidable, a sufficient safety factor must be secured.

### Lifting Force, Moment, Horizontal Force

To lift a workpiece vertically, make sure to take into consideration the acceleration rate, wind pressure, impact, etc., in addition to the mass of the workpiece. (Refer to Fig. 1)

Because the pads are susceptible to moments, mount the pad so as not to allow the workpiece to create a moment. (Refer to Fig. 2)

When a workpiece that is suspended horizontally is moved laterally, the workpiece could shift depending on the extent of the acceleration rate or the size of the friction coefficient between the pad and the workpiece. Therefore, the acceleration rate of the lateral movement must be minimized. (Refer to Fig. 3)

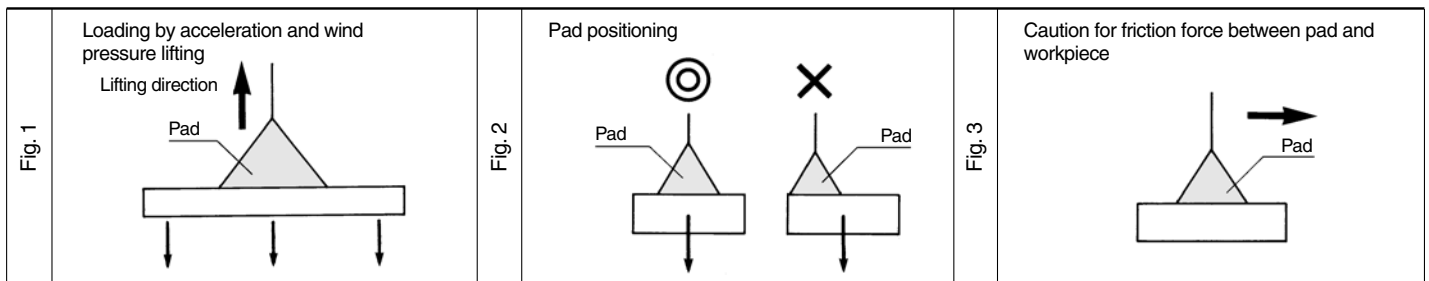

### Balance of Pad and Workpiece

Make sure that the pad's suction surface is not larger than the surface of the workpiece to prevent vacuum leakage and unstable picking.

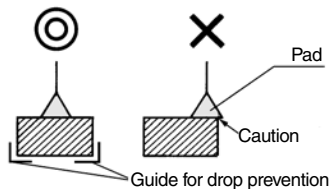

If multiple pads are used for transferring a flat object with a large surface area, properly allocate the pads to maintain balance. Also make sure that the pads are aligned properly to prevent them from becoming disengaged along the edges.

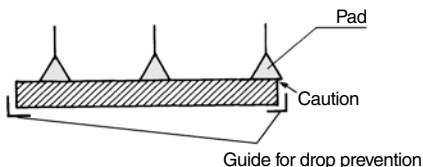

Provide an auxiliary device (example: a guide for preventing the workpieces from dropping) as necessary.

### Mounting Position

As a rule, the unit must be installed horizontally. Although a diagonal or a vertical installation should be avoided whenever possible, if the unit must be installed in such a manner, be certain to guarantee guide and absolute safety.

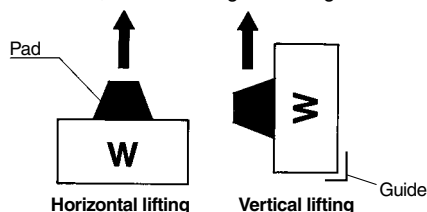

# Model Selection

## ● Lifting Force and Vacuum Pad Diameter

### 1. Theoretical Lifting Force

- Set the vacuum pressure below the pressure that has been stabilized after adsorption.
- However, when a workpiece is permeable or has a rough surface, note that the vacuum pressure drops since the workpiece takes air in. In such a case, carry out an adsorption test for confirmation.
- The vacuum pressure when using an ejector is approximately -60 kPa as a guide.

The theoretical lifting force of a pad can be found by calculation or from the theoretical lifting force table.

#### Calculation

$$W = P \times S \times 0.1 \times \frac{1}{t}$$

**W** : Lifting force (N)  
**P** : Vacuum pressure (kPa)  
**S** : Pad area (cm<sup>2</sup>)  
**t** : Safety factor    Horizontal lifting: 4 or more  
                                  Vertical lifting: 8 or more

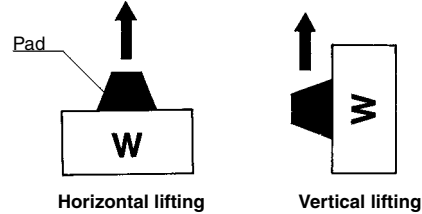

(This type of application should basically be avoided.)

#### Theoretical Lifting Force

The theoretical lifting force (not including the safety factor) is found from the pad diameter and vacuum pressure. The required lifting force is then found by dividing the theoretical lifting force by the safety factor **t**.

$$\text{Lifting force} = \text{Theoretical lifting force} \div t$$

#### (1) Theoretical Lifting Force (Theoretical lifting force = $P \times S \times 0.1$ )



(N)

Pad diameter (mm)	ø1.5	ø2	ø3.5	ø4	ø6	ø8	ø10	ø13	ø16	
Pad area S (cm <sup>2</sup> )	0.02	0.03	0.10	0.13	0.28	0.50	0.79	1.33	2.01	
Vacuum pressure (kPa)	-85	0.15	0.27	0.82	1.07	2.4	4.2	6.6	11.3	17.1
	-80	0.14	0.25	0.77	1.00	2.2	4.0	6.2	10.6	16.1
	-75	0.13	0.24	0.72	0.94	2.1	3.7	5.8	10.0	15.1
	-70	0.12	0.22	0.67	0.88	1.9	3.5	5.5	9.3	14.1
	-65	0.11	0.20	0.63	0.82	1.8	3.2	5.1	8.6	13.1
	-60	0.11	0.19	0.58	0.75	1.7	3.0	4.7	8.0	12.1
	-55	0.10	0.17	0.53	0.69	1.5	2.7	4.3	7.3	11.1
	-50	0.09	0.16	0.48	0.63	1.4	2.5	3.9	6.7	10.0
	-45	0.08	0.14	0.43	0.57	1.2	2.2	3.5	6.0	9.0
-40	0.07	0.13	0.38	0.50	1.1	2.0	3.1	5.3	8.0	

## ● Vacuum Pad Type

- Flat type, flat with groove and bellows type are available in the ZP3 series. Select the appropriate shape to suit the workpiece and operating environment.

### Pad Type

Pad type	Application
Flat 	To be used when adsorption surface of a workpiece is flat and not deformed.
Flat with groove 	To be used to ensure removal of a workpiece.
Bellows 	To be used when there is not enough space to install a buffer or adsorption surface of a workpiece is inclined.

## ● Vacuum Pad Material

- It is necessary to determine vacuum pad materials carefully taking into account the workpiece shape, adaptability in the operating environment, effect after being adsorbed, electrical conductivity, etc.
- Based on the workpiece transfer example for each material, select after confirming the characteristics (adaptability) of rubber.

### Vacuum Pad/Example of Workpiece Transfer

#### Material

Material	Application
NBR	Transfer of general workpieces, Corrugated board, Veneer plate, Iron plate and others
Silicone rubber	Semiconductor, Removing from die-casting, Thin workpieces, Food processor
Urethane rubber	Corrugated board, Iron plate, Veneer plate
FKM	Chemical workpieces
Conductive NBR	General workpieces of semiconductor (Static electricity resistance)
Conductive silicone rubber	Semiconductor (Static electricity)

# Model Selection

## ● Rubber Material and Properties

General name	NBR (Nitrile rubber)	Silicone rubber	Urethane rubber	FKM (Fluoro rubber)	Conductive NBR (Nitrile rubber)	Conductive silicone rubber	
Main features	Good oil resistance, abrasion resistance, and aging resistance	Excellent heat resistance, and cold resistance	Excellent mechanical strength	Best heat resistance, and chemical resistance	Good oil resistance, abrasion resistance, and aging resistance. Conductive	Very excellent heat resistance, and cold resistance. Conductive	
Pure gum property (specific gravity)	1.00-1.20	0.95-0.98	1.00-1.30	1.80-1.82	1.00-1.20	0.95-0.98	
Physical properties of blended gum	Impact resilience	○	◎	◎	△	○	◎
	Abrasion resistance	◎	×/△	◎	◎	◎	×/△
	Tear resistance	○	×/△	◎	○	○	×/△
	Flex crack resistance	○	×/○	◎	○	○	×/○
	Maximum operation temperature °C	120	200	60	250	100	200
	Minimum operation temperature °C	0	-30	0	0	0	-10
	Volume resistivity (Ωcm)	—	—	—	—	10 <sup>4</sup> or less	10 <sup>4</sup> or less
	Heat aging	○	◎	△	◎	○	◎
	Weather resistance	○	◎	◎	◎	○	◎
	Ozone resistance	△	◎	◎	◎	△	◎
	Gas permeability resistance	○	×/△	×/△	×/△	○	×/△
Chemical resistance Oil resistance	Gasoline/Gas oil	◎	×/△	◎	◎	◎	×/△
	Benzene/Toluene	×/△	×	×/△	◎	×/△	×
	Alcohol	◎	◎	△	△/◎	◎	◎
	Ether	×/△	×/△	×	×/△	×/△	×/△
	Ketone (MEK)	×	○	×	×	×	○
	Ethyl acetate	×/△	△	×/△	×	×/△	△
Alkaline resistance Acid resistance	Water	◎	○	△	◎	◎	○
	Organic acid	×/△	○	×	△/○	×/△	○
	Organic acid of high concentration	△/○	△	×	◎	△/○	△
	Organic acid of low concentration	○	○	△	◎	○	○
	Strong alkali	○	◎	×	○	○	◎
Weak alkali	○	◎	×	○	○	◎	

◎ = Excellent --- Not affected at all, or almost no effect

○ = Good --- Affected a little, but adequate resistance depending on conditions

△ = Better not to use if possible

× = Unsuitable for usage. Severely affected.

\* Properties, chemical resistance, and other values are not guaranteed. These values depend on the operating environment, so they cannot be guaranteed by SMC. Thorough research and confirmation are necessary before usage.

## ● Color and Identification

General name	NBR (Nitrile rubber)	Silicone rubber	Urethane rubber	FKM (Fluoro rubber)	Conductive NBR (Nitrile rubber)	Conductive silicone rubber
Color of rubber	Black	White	Brown	Black	Black	Black
Identification (Dot)	—	—	—	· Green 1 dot	· Silver 1 dot	· Pink 1 dot
Rubber hardness HS (±5°)	A60/S					

## ● Buffer Attachment

- Choose buffer type when the workpieces are of varying heights, the workpieces are fragile, or you need to reduce the impact to the pad. If rotation needs to be limited, use non-rotating buffer.

### Unsteady Distance between Pad and Workpiece

When the workpieces are of varying heights, use the buffer type pad with built-in spring. The spring creates a cushion effect between the pad and the workpieces. If rotation needs to be limited further, use non-rotating buffer type.

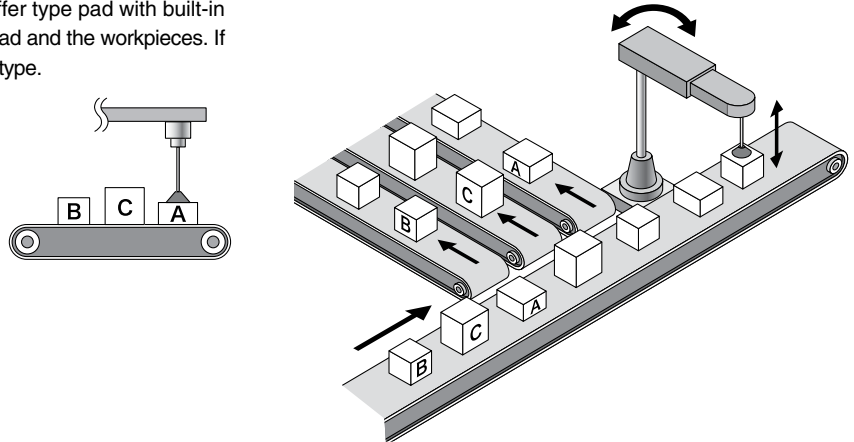

## ● Pad Selection by Workpiece Type

- Carefully select a pad for the following workpieces.

### 1. Porous Workpiece

To pick a permeable workpiece such as paper, select a pad with a small diameter that is sufficient to lift the workpiece. Because a large amount of air leakage could reduce the pad's suction force, it may be necessary to increase the capacity of an ejector or vacuum pump or enlarge the conductance area of the piping passage.

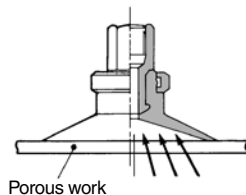

### 2. Flat Plate Workpiece

When a workpiece with a large surface area such as sheet glass or PCB is suspended, the workpiece could move in a wavelike motion if a large force is applied by wind pressure or by an impact. Therefore, it is necessary to ensure the proper allocation and size of pads.

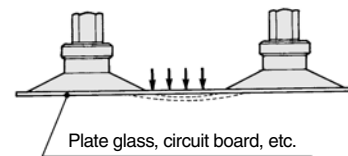

### 3. Soft Workpiece

If a soft workpiece such as vinyl, paper, or thin sheet is picked up, the vacuum pressure could cause the workpiece to deform or wrinkle. In such a case, it will be necessary to use a small pad or a ribbed pad and reduce the vacuum pressure.

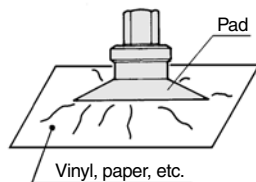

### 4. Impact to Pad

When pushing a pad to a workpiece, make sure not to apply an impact or a large force which would lead to premature deformation, cracking, or wearing of the pad. The pad should be pushed against the workpiece to the extent that its skirt portion deforms or that its ribbed portion comes into slight contact with the workpiece. Especially, when using a smaller diameter pad, make sure to locate it correctly.

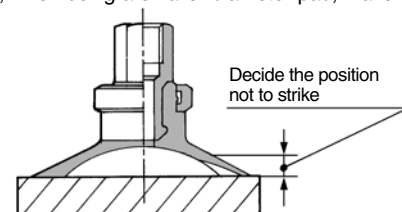

## ● Vacuum Pad Durability

- Need to be careful of the vacuum pad (rubber) deterioration.
- The vacuum pad's adsorption surface will be worn out when it is used for a certain period of time, and the outer diameter gradually becomes smaller. The lifting force becomes weaker as the pad diameter becomes smaller, but adsorption is still possible.
- Decide when to replace the vacuum pads, taking into account the customer's operating conditions, and signs of deterioration such as changes in the appearance due to wear, reduction in the vacuum pressure that is reached, and delay in the adsorption response time.

# Model Selection

## 3 Selection of Vacuum Ejector and Vacuum Switching Valve

### ● Calculating Vacuum Ejector and Switching Valve Size with the Formula

Average suction flow rate for achieving adsorption response time

$$Q = \frac{V \times 60}{T_1} + Q_L$$

$$T_2 = 3 \times T_1$$

**Q** : Average suction flow rate L/min (ANR)

**V** : Piping capacity (L)

**T<sub>1</sub>** : Arrival time to stable **P<sub>v</sub>** 63% after adsorption (sec)

**T<sub>2</sub>** : Arrival time to stable **P<sub>v</sub>** 95% after adsorption (sec)

**Q<sub>L</sub>** : Leakage volume during workpiece adsorption L/min (ANR) Note 1)

Max. suction flow rate

$$Q_{max} = (2 \text{ to } 3) \times Q \text{ L/min (ANR)}$$

<Selection Procedure>

• **Ejector**

Select the ejector with the greater maximum suction flow rate from the **Q<sub>max</sub>** indicated above.

• **Direct operation valve**

$$\text{Conductance } C = \frac{Q_{max}}{55.5} [\text{dm}^3/(\text{s}\cdot\text{bar})]$$

\* Select a valve (solenoid valve) having a conductance that is greater than that of the conductance **C** formula given above from the related equipment (page 1278 in Best Pneumatics No. 4).

Note 1) **Q<sub>L</sub>**: 0 when no leakage occurs during adsorbing a workpiece.

If there is leakage during adsorbing a workpiece, find the leakage volume based on "4. Leakage Volume during Workpiece Adsorption."

Note 2) Tube piping capacity can be found in "8. Data: Piping Capacity by Tube I.D. (Selection Graph (2))."

## 4 Leakage Volume during Workpiece Adsorption

Air could be drawn in depending on the type of workpiece. As a result, the vacuum pressure in the pad becomes reduced and the amount of vacuum that is necessary for adsorption cannot be attained.

When this type of workpiece must be handled, it is necessary to select the proper size of the ejector and the vacuum switching valve by taking into consideration the amount of air that could leak through the workpiece.

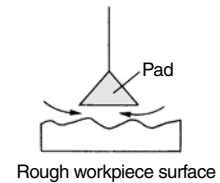
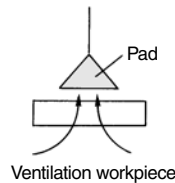

### ● Leakage Volume from Conductance of Workpiece

$$\text{Leakage volume } Q_L = 55.5 \times C_L$$

**Q<sub>L</sub>**: Leakage volume L/min (ANR)

**C<sub>L</sub>**: Conductance between workpiece and pad, and workpiece opening area [dm<sup>3</sup>/(s·bar)]

### ● Leakage Volume from Adsorption Test

As described in the illustration below, pick up the workpiece with the ejector, using an ejector, pad and a vacuum gauge.

At this time, read vacuum pressure **P<sub>1</sub>**, obtain the suction flow rate from the flow-rate characteristics graph for the ejector that is being used, and render this amount as the leakage of the workpiece.

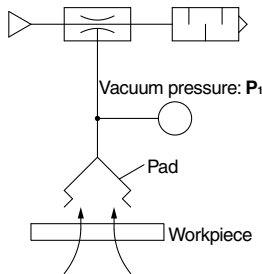

**Exercise:** Using a supply pressure of 0.45 MPa, when the ejector (ZH07□S) picks up a workpiece that leaks air, the vacuum gauge indicated a pressure of -53 kPa. Calculate the leakage volume from the workpiece.

<Selection Procedure>

When obtaining the suction flow rate at a vacuum pressure of -53 kPa from the ZH07DS flow-rate characteristics graph, the suction flow rate is 5 L/min (ANR). (A)→(B)→(C)

$$\text{Leakage volume} \approx \text{Suction flow rate } 5 \text{ L/min (ANR)}$$

### ZH07BS, ZH07DS

#### Exhaust Characteristics

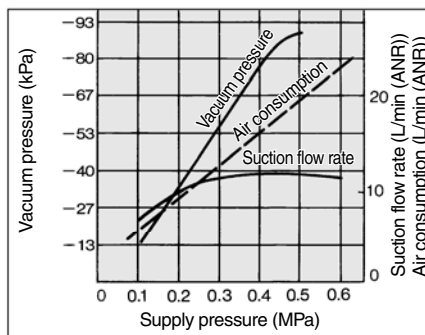

#### Flow-rate Characteristics

Supply pressure {0.45 MPa}

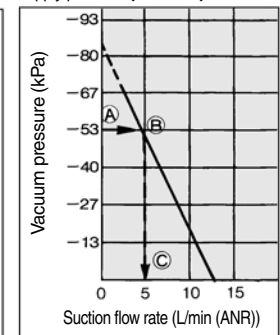

## 5 Adsorption Response Time

When a vacuum pad is used for the adsorption transfer of a workpiece, the approximate adsorption response time can be obtained (the length of time it takes for the pad's internal vacuum pressure to reach the pressure that is required for adsorption after the supply valve {vacuum switching valve} has been operated). An approximate adsorption response time can be obtained through formulas and selection graphs.

### ● Relationship between Vacuum Pressure and Response Time after Supply Valve (Switching Valve) is Operated

The relationship between vacuum pressure and response time after the supply valve (switching valve) is operated as shown below.

**Vacuum System Circuit**

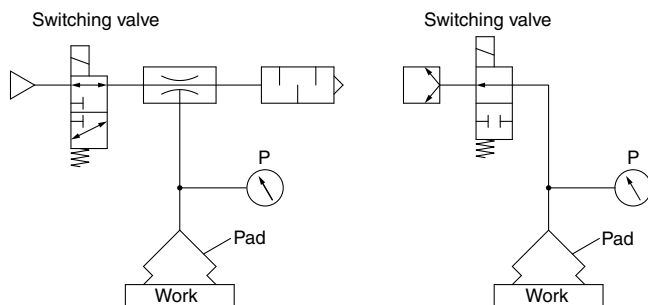

**Vacuum Pressure and Response Time after Supply Valve (Switching Valve) is Operated**

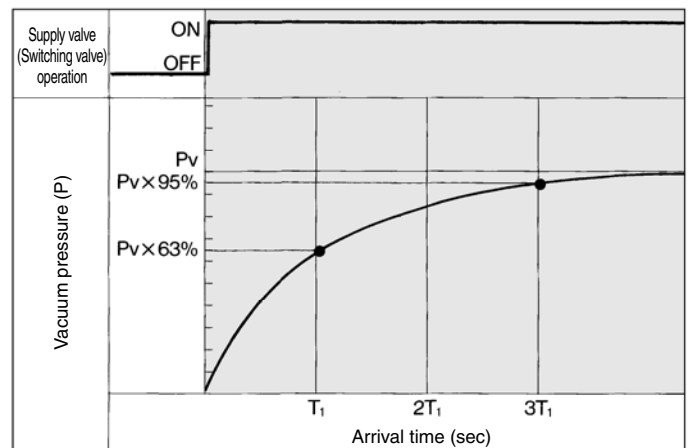

**P<sub>v</sub>** : Final vacuum pressure  
**T<sub>1</sub>** : Arrival time to 63% of final vacuum pressure **P<sub>v</sub>**  
**T<sub>2</sub>** : Arrival time to 95% of final vacuum pressure **P<sub>v</sub>**

### ● Calculating Adsorption Response Time with the Formula

Adsorption response times **T<sub>1</sub>** and **T<sub>2</sub>** can be obtained through the formulas given below.

$$\text{Adsorption response time } T_1 = \frac{V \times 60}{Q}$$

$$\text{Adsorption response time } T_2 = 3 \times T_1$$

**Piping capacity**

$$V = \frac{3.14}{4} D^2 \times L \times \frac{1}{1000} \text{ (L)}$$

**T<sub>1</sub>** : Arrival time to 63% of final vacuum pressure **P<sub>v</sub>** (sec)

**T<sub>2</sub>** : Arrival time to 95% of final vacuum pressure **P<sub>v</sub>** (sec)

**Q<sub>1</sub>** : Average suction flow rate L/min [ANR]

Calculation of average suction flow rate

- Ejector

$$Q_1 = (1/2 \text{ to } 1/3) \times \text{Ejector max. suction flow rate L/min [ANR]}$$

- Vacuum pump

$$Q_1 = (1/2 \text{ to } 1/3) \times 55.5 \times \text{Conductance of vacuum pump [dm}^3\text{/(s-bar)]}$$

**D** : Piping diameter (mm)

**L** : Length from ejector and switch valve to pad (m)

**V** : Piping capacity from ejector and switching valve to pad (L)

**Q<sub>2</sub>** : Max. flow from ejector and switching valve to pad by piping system

$$Q_2 = C \times 55.5 \text{ L/min [ANR]}$$

**Q** : Smaller one between the **Q<sub>1</sub>** and **Q<sub>2</sub>** L/min [ANR]

**C** : Conductance of piping [dm<sup>3</sup>/(s-bar)]

For the conductance, the equivalent conductance can be found in "8. Data: Conductance by Tube I.D. (Selection Graph (3))."



# Model Selection

## ● Adsorption Response Time from the Selection Graph

### 1. Tube Piping Capacity

Piping capacity from the ejector and switching valve at vacuum pump to the pad can be found in “8. Data: Piping Capacity by Tube I.D. (Selection Graph (2)).”

### 2. Obtain the adsorption response times.

By operating the supply valve (switching valve) that controls the ejector (vacuum pump), the adsorption response times  $T_1$  and  $T_2$  that elapsed before the prescribed vacuum pressure is reached can be obtained from the Selection Graph (1).

Selection Graph (1) Adsorption Response Time

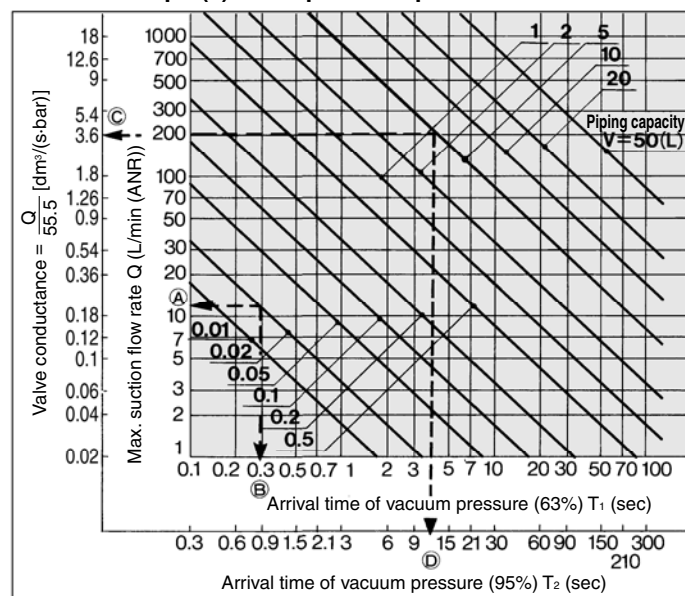

\* Conversely, the size of the ejector or the size of the switching valve of the vacuum pump system can be obtained from the adsorption response time.

### How to read the graph

Example 1: For obtaining the adsorption response time until the pressure in the piping system with a piping capacity of 0.02 L is discharged to 63% ( $T_1$ ) of the final vacuum pressure through the use of the vacuum ejector ZH07□S with a maximum suction flow rate of 12 L/min (ANR).

#### <Selection Procedure>

From the point at which the vacuum ejector's maximum vacuum suction flow rate of 12 L/min (ANR) and the piping capacity of 0.02 L intersect, the adsorption response time  $T_1$  that elapses until 63% of the maximum vacuum pressure is reached can be obtained. (Sequence in Selection Graph (1), (A)→(B))  $T_1 \approx 0.3$  seconds.

Example 2: For obtaining the discharge response time until the internal pressure in the 5 L tank is discharged to 95% ( $T_2$ ) of the final vacuum pressure through the use of a valve with a conductance of 3.6 [dm³/(s·bar)].

#### <Selection Procedure>

From the point at which the valve's conductance of 3.6 [dm³/(s·bar)] and the piping capacity of 5 L intersect, the discharge response time ( $T_2$ ) that elapses until 95% of the final vacuum pressure is reached can be obtained. (Sequence in Selection Graph (1), (C)→(D))  $T_2 \approx 12$  seconds.

## 6 Precautions on Vacuum Equipment Selection and SMC's Proposal

### ● Safety Measures

- Make sure to provide a safe design for a vacuum pressure drop due to a disruption of power supply, or a lack of supply air. Drop prevention measures must be taken in particular when dropping a workpiece presents some degree of danger.

### ● Precautions on Vacuum Equipment Selection

As a countermeasure for power outages, select a supply valve that is normally open or one that is equipped with a self-holding function.

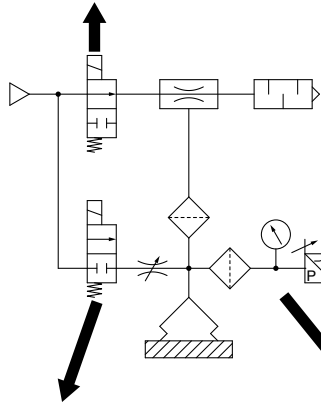

For the release valve, select a 2/3 port valve with a low vacuum specification. Also, use a needle valve to regulate the release flow rate.

- During the adsorption and transfer of a workpiece, verification of the vacuum switch is recommended.
- In addition, visually verify the vacuum gauge when handling a heavy or a hazardous item.
- The ZSP1 type is optimal for the adsorption and transfer of small parts using a suction nozzle with a small diameter.
- Install a filter (Series ZFA, ZFB, ZFC) before the pressure switch if the ambient air is of low quality.

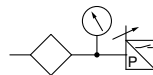

Select a vacuum switching valve that has a conductance that does not reduce the composite conductance consisting of the areas from the pad to the ejector.

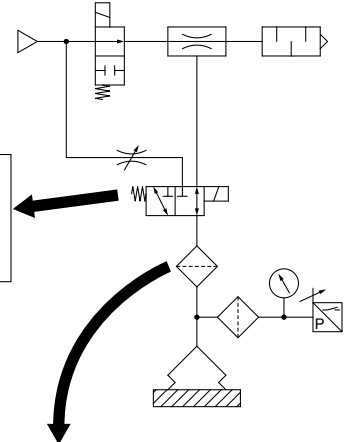

Use a suction filter (Series ZFA, ZFB, ZFC) to protect the switching valve and to prevent the ejector from becoming clogged. Also, a suction filter must be used in a dusty environment. If only the unit's filter is used, it will become clogged quickly.

### ● Vacuum Ejector or Pump and Number of Vacuum Pads

Ejector and number of pads		Vacuum pump and number of pads	
Ideally, one pad should be used for each ejector.	When more than one pad is attached to a single ejector, if one of the workpieces becomes detached, the vacuum pressure will drop, causing other workpieces to become detached. Therefore, the countermeasures listed below must be taken. <ul style="list-style-type: none"> <li>• Adjust the needle valve to minimize the pressure fluctuation between adsorption and non-adsorption operations.</li> <li>• Provide a vacuum switching valve to each individual pad to minimize the influences on other pads if an adsorption error occurs.</li> </ul>	Ideally, one pad should be used for each line.	When more than one pad is attached to a single vacuum line, take the countermeasures listed below. <ul style="list-style-type: none"> <li>• Adjust the needle valve to minimize the pressure fluctuation between adsorption and non-adsorption operation.</li> <li>• Include a tank and a vacuum pressure reduction valve (vacuum pressure regulator valve) to stabilize the source pressure.</li> <li>• Provide a vacuum switching valve to each individual pad to minimize the influences on other pads if an adsorption error occurs.</li> </ul>

# Model Selection

## ● Vacuum Ejector Selection and Handling Precautions

### Ejector Selection

There are 2 types of ejector flow-rate characteristics: the high vacuum type (S type) and the high flow type (L type). During the selection, pay particular attention to the vacuum pressure when adsorbing workpieces that leak.

#### High Vacuum Type Flow-rate Characteristics/ ZH13□S

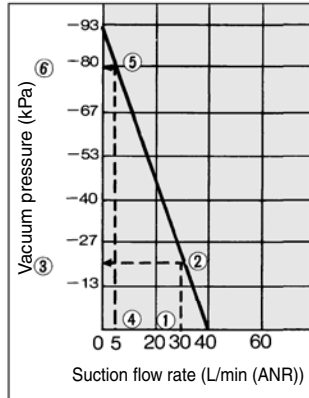

#### High Flow Type Flow-rate Characteristics/ ZH13□L

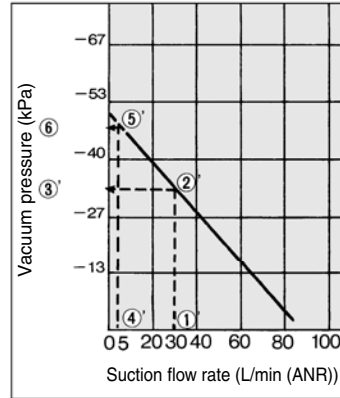

The vacuum pressure varies in accordance with the leakage volumes indicated in the above diagrams.

If the leakage volume is 30 L/min (ANR), the vacuum pressure of the S type is -20 kPa ① → ② → ③, and for the L type it is -33 kPa ①' → ②' → ③'. If the leakage volume is 5 L/min (ANR), the vacuum pressure of the S type is -80 kPa ④ → ⑤ → ⑥, and for the L type it is -47 kPa ④' → ⑤' → ⑥'. Thus, if the leakage volume is 30 L/min (ANR) the L type can attain a higher vacuum pressure, and if the leakage volume is 5 L/min (ANR), the S type can attain a higher vacuum pressure.

Thus, during the selection process, make sure to take the flow-rate characteristics of the high vacuum type (S type) and the high flow type (L type) into consideration in order to select the type that is optimal for your application.

- If the vacuum ejector makes an intermittent noise (abnormal noise) from exhaust at a certain supply pressure, the vacuum pressure will not be stable. It will not be any problem if the vacuum ejector is used under this condition. However, if the noise is disturbing or might affect the operation of the vacuum pressure switch, lower or raise supply pressure a little at a time, and use in an air pressure range that does not produce the intermittent noise.

## ● Supply Pressure of Vacuum Ejector

- Use the vacuum ejector at the standard supply pressure. The maximum vacuum pressure and suction flow rate can be obtained when the vacuum ejector is used at the standard supply pressure, and as a result, adsorption response time also improves. From the viewpoint of energy-saving, it is the most effective to use the ejector at the standard supply pressure. Since using it at the excessive supply pressure causes a decline in the ejector performance, do not use it at a supply pressure exceeding the standard supply.

### Ejector Nozzle Diameter Selection

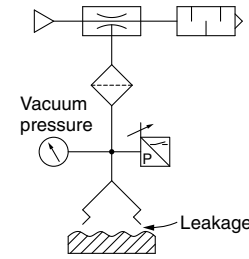

If a considerable amount of leakage occurs between the workpiece and the pad, resulting in incomplete adsorption, or to shorten the adsorption and transfer time, select an ejector nozzle with a larger diameter from the ZH, ZM, ZR, or ZL series.

### Manifold Use

#### Individual exhaust

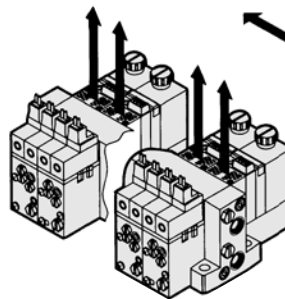

#### Centralized exhaust

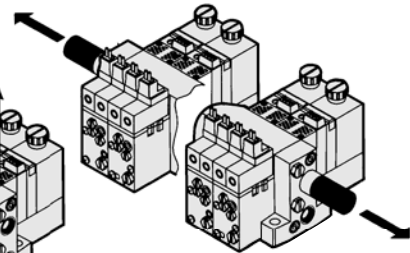

If there are a large number of ejectors that are linked on a manifold and operate simultaneously, use the built-in silencer type or the port exhaust type.

If there are a large number of ejectors that are linked on a manifold, which exhaust collectively, install a silencer at both ends. If the exhaust must be discharged outdoors through piping, make sure that the diameter of the piping is large enough that its back pressure will not affect the operation of the ejectors.

## ● Timing for Vacuum Generation and Suction Verification

### A. Timing for Vacuum Generation

The time for opening/closing the valve will be counted if a vacuum is generated after the adsorption pad descends to adsorb a workpiece. Also, there is a timing delay risk for the generating vacuum since the operational pattern for the verification switch, which is used for detecting the descending vacuum pad, is not even.

To solve this issue, we recommend that vacuum be generated in advance, before the vacuum pad begins to descend to the workpiece. Adopt this method after confirming that there will be no misalignment resulting from the workpiece's light mass.

### B. Suction Verification

When lifting the vacuum pad after absorbing a workpiece, confirm that there is a suction verification signal from the vacuum pressure switch, before the vacuum pad is lifted. If the vacuum pad is lifted, based on the timing of a timer, etc., there is a risk that the workpiece may be left behind.

In general adsorption transfer, the time for adsorbing a workpiece is slightly different since the position of the vacuum pad and the workpiece are different after every operation. Therefore, program a sequence in which the suction completion is verified by a vacuum pressure switch, etc. before moving to the next operation.

### C. Set Pressure for Vacuum Pressure Switch

Set the optimum value after calculating the required vacuum pressure for lifting a workpiece.

If a higher pressure than required is set, there is a possibility of being unable to confirm the suction even though the workpiece is adsorbed. This will result in a suction error.

When setting vacuum pressure switch set values, you should set using a lower pressure, with which a workpiece can be adsorbed, only after considering the acceleration or vibration when a workpiece is transferred. The set value of the vacuum pressure switch shortens the time to lift a workpiece. Since the switch detects whether the workpiece is lifted or not, the pressure must be set high enough to detect it.

#### Vacuum Pressure Switch (Series ZS), Vacuum Pressure Gauge (Series GZ)

When adsorbing and transferring a workpiece, verify at the vacuum pressure switch as much as possible (In addition, visually verify the vacuum gauge, especially when handling a heavy or a hazardous item.)

##### Approx. $\phi 1$ adsorption nozzle

The difference in pressure between ON and OFF becomes small depending on the capacity of the ejector and vacuum pump. In such a case, **it will be necessary to use ZSP1 that can detect a small hysteresis or a flow switch.**

Note) • **A vacuum generator with a large suction capacity will not be detected properly**, so an ejector with an appropriate capacity must be selected.

- Since the hysteresis is small, vacuum pressure must be stabilized.



Suction verification switch  
ZSP1



Flow sensor  
PFMV



Vacuum pressure gauge  
GZ46

Refer to the Best Pneumatics No. 6 for details.

#### Timing Chart Example

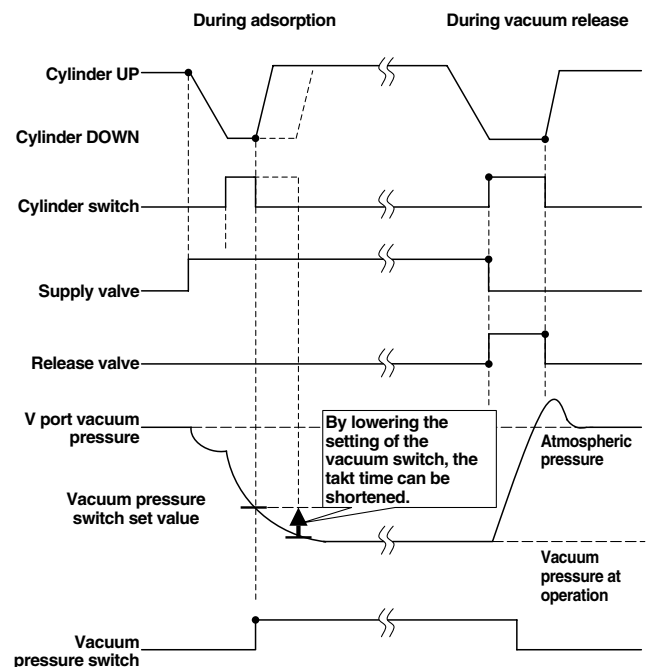

# Model Selection

## ● Dust Handling of Vacuum Equipment

- When the vacuum equipment is used, not only the workpiece, but also dust in the surrounding environment is taken in the equipment. Preventing the intrusion of dust is required more than for any other pneumatic equipment. Some of SMC's vacuum equipment comes with a filter, but when there is a large amount of dust, an additional filter must be installed.
- When vaporized materials such as oil or adhesive are sucked into the equipment, they accumulate inside, which may cause problems.
- It is important to prevent dust from entering the vacuum equipment as much as possible.
  - (1) Make sure to keep the working environment and surrounding area of the workpiece clean so that dust will not be sucked in the equipment.
  - (2) Check the amount and types of dust before using the equipment and install a filter, etc., in the piping when necessary. In particular, equipment used to capture dust, such as a vacuum cleaner, require a special filter.
  - (3) Conduct a test and make sure that operating conditions are cleared before using the equipment.
  - (4) Perform filter maintenance depending on the amount of dirt.
  - (5) Filter clogging generates a pressure difference between the adsorption and ejector parts. This requires attention, since clogging can prevent proper adsorption from being achieved.

### Air Suction Filter (Series ZFA, ZFB, ZFC)

- To protect the switching valve and the ejector from becoming clogged, a suction filter in the vacuum circuit is recommended.
- When using an ejector in a dusty environment, the unit's filter will become clogged quickly, so it is recommended that the ZFA, ZFB or ZFC series be used concurrently.

### Vacuum Line Equipment Selection

Determine the volume of the suction filter and the conductance of the switching valve in accordance with the maximum suction flow rate of the ejector and the vacuum pump. Make sure that the conductance is greater than the value that has been obtained through the formula given below. (If the devices are connected in series in the vacuum line, their conductances must be combined.)

$$C = \frac{Q_{\max}}{55.5}$$

**C:** Conductance [dm<sup>3</sup>/(s·bar)]  
**Q<sub>max</sub>:** Max. suction flow rate L/min (ANR)

## 7 Vacuum Equipment Selection Example

### ● Transfer of Semiconductor Chips

#### Selection conditions:

- (1) Workpiece: Semiconductor chips  
Dimensions: 8 mm x 8 mm x 1 mm, Mass: 1 g
- (2) Vacuum piping length: 1 m
- (3) Adsorption response time: 300 msec or less

#### 1. Vacuum Pad Selection

- (1) Based on the workpiece size, the pad diameter is 4 mm (1 pc.).
- (2) Using the formula on the front matter 4, confirm the lifting force.

$$\begin{aligned} W &= P \times S \times 0.1 \times 1/t \\ 0.0098 &= P \times 0.13 \times 0.1 \times 1/4 \\ P &= 3.0 \text{ kPa} \end{aligned}$$

$$\begin{cases} W = 1 \text{ g} = 0.0098 \text{ N} \\ S = \pi/4 \times (0.4)^2 = 0.13 \text{ cm}^2 \\ t = 4 \text{ (Horizontal lifting)} \end{cases}$$

According to the calculation, -3.0 kPa or more of vacuum pressure can adsorb the workpiece.

- (3) Based on the workpiece shape and type, select:  
Pad type: Flat  
Pad material: Silicone
- (4) According to the results above, select a vacuum pad part number ZP3-04US-□□.  
(Specify the vacuum inlet type (□□) from the pad mounting status.)

#### 2. Vacuum Ejector Selection

- (1) Find the vacuum piping capacity.  
Assuming that the tube I.D. is 2 mm, the piping capacity is as follows:
- (2) Assuming that leakage ( $Q_L$ ) during adsorption is 0, find the average suction flow rate to meet the adsorption response time using the formula on the front matter 8.

$$\begin{aligned} V &= \pi/4 \times D^2 \times L \times 1/1000 = \pi/4 \times 2^2 \times 1 \times 1/1000 \\ &= 0.0031 \text{ L} \end{aligned}$$

$$Q = (V \times 60) / T_1 + Q_L = (0.0031 \times 60) / 0.3 + 0 = 0.62 \text{ L}$$

From the formula on the front matter 8, the maximum suction flow rate  $Q_{max}$  is

$$\begin{aligned} Q_{max} &= (2 \text{ to } 3) \times Q = (2 \text{ to } 3) \times 0.62 \\ &= 1.24 \text{ to } 1.86 \text{ L/min (ANR)} \end{aligned}$$

According to the maximum suction flow rate of the vacuum ejector, a nozzle with a 0.5 diameter can be used.  
If the vacuum ejector ZX series is used, representative model ZX105□ can be selected.  
(Based on the operating conditions, specify the complete part number for the vacuum ejector used.)

#### 3. Adsorption Response Time Confirmation

Confirm the adsorption response time based on the characteristics of the vacuum ejector selected.

- (1) The maximum suction flow rate of the vacuum ejector ZX105□ is 5 L/min (ANR). From the formula on the front matter 9, the average suction flow rate  $Q_1$  is as follows:

$$\begin{aligned} Q_1 &= (1/2 \text{ to } 1/3) \times \text{Ejector max. suction flow rate} \\ &= (1/2 \text{ to } 1/3) \times 5 = 2.5 \text{ to } 1.7 \text{ L/min (ANR)} \end{aligned}$$

- (2) Next, find the maximum flow rate  $Q_2$  of the piping. The conductance  $C$  is 0.22 from the Selection Graph (3).  
From the formula on the front matter 9, the maximum flow rate is as follows:

$$Q_2 = C \times 55.5 = 0.22 \times 55.5 = 12.2 \text{ L/min (ANR)}$$

- (3) Since  $Q_2$  is smaller than  $Q_1$ ,  $Q = Q_1$ .

Thus, from the formula on the front matter 9, the adsorption response time is as follows:

$$\begin{aligned} T &= (V \times 60) / Q = (0.0031 \times 60) / 1.7 = 0.109 \text{ seconds} \\ &= 109 \text{ msec} \end{aligned}$$

It is possible to confirm that the calculation result satisfies the required specification of 300 msec.

# Model Selection

## 8 Data

### ● Selection Graph

Selection Graph (2) Piping Capacity by Tube I.D.

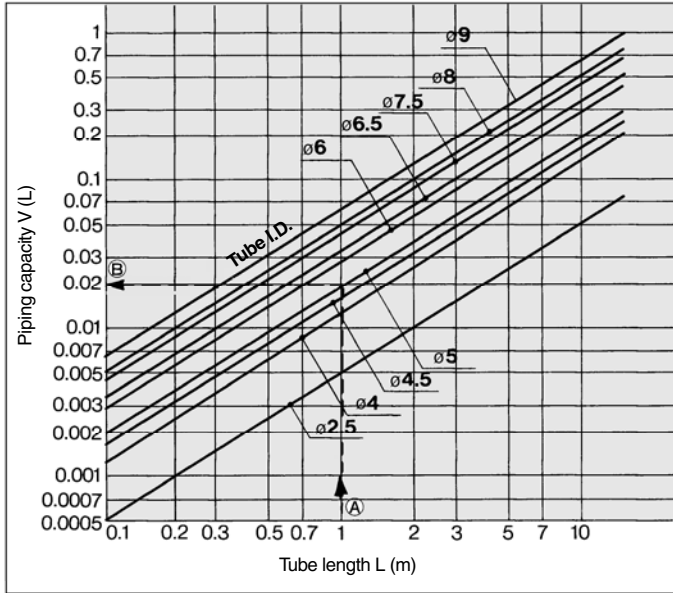

#### How to read the graph

Example: For obtaining the capacity of tube I.D. ø5 and 1 meter length

#### <Selection Procedure>

By extending leftward from the point at which the 1 meter tube length on the horizontal axis intersects the line for a tube I.D. ø5, the piping capacity approximately equivalent to 0.02 L can be obtained on the vertical axis.

**Piping capacity  $\approx 0.02 L$**

Selection Graph (3) Conductance by Tube I.D.

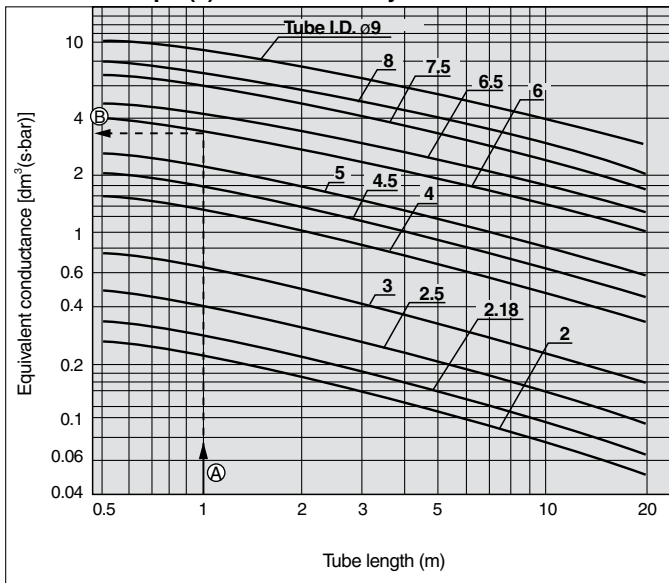

#### How to read the graph

Example: Tube size ø8/ø6 and 1 meter length

#### <Selection Procedure>

By extending leftward from the point at which the 1 meter tube length on the horizontal axis intersects the line for a tube I.D. ø6, the equivalent conductance approximately 3.6 [dm³/(s·bar)] can be obtained on the vertical axis.

**Equivalent conductance  $\approx 3.6$  [dm³/(s·bar)]**



## ● Glossary of Terms

Terms	Description
(Max.) suction flow rate	Volume of air taken in by the ejector. The maximum value is the volume of air taken in without having anything connected to the vacuum port.
Maximum vacuum pressure	The maximum value of the vacuum pressure generated by the ejector
Air consumption	The compressed volume of air consumed by the ejector
Standard supply pressure	The optimal supply pressure for operating the ejector
Exhaust characteristics	The relationship between the vacuum pressure and the suction flow rate when the supply pressure to the ejector has been changed.
Flow-rate characteristics	The relationship between the vacuum pressure and the suction flow rate with the standard supply pressure supplied to the ejector.
Vacuum pressure switch	Pressure switch for verifying the adsorption of a workpiece
Suction verification switch	Switch, based on an air pressure bridge, for verifying the adsorption of a workpiece. It is used when the adsorption pad and the nozzle are extremely small.
(Air) supply valve	Valve for supplying compressed air to the ejector
(Vacuum) release valve	Valve for supplying positive pressure or air for breaking the vacuum state of the adsorption pad
Flow adjustment valve	Valve for adjusting the volume of air for breaking the vacuum
Release pressure	Pressure for breaking the vacuum
Pilot pressure	Pressure for operating the ejector valve
External release	The action of breaking the vacuum using externally supplied air instead of using the ejector unit
Vacuum port	Port for generating vacuum
Exhaust port	Port for exhausting air consumed by the ejector, and air taken in from the vacuum port.
Supply port	Port for supplying air to the ejector
Back pressure	Pressure inside the exhaust port
Leakage	The entry of air into the vacuum passage, such as from an area between a workpiece and a pad, or between a fitting and a tube. The vacuum pressure decreases when leakage occurs.
Response time	The time from the application of the rated voltage to the supply valve or release valve, until V port pressure reaches the specified pressure.
Average suction flow rate	The suction flow rate by the ejector or pump for calculating the response speed. It is 1/2 to 1/3 of the maximum suction flow rate.
Conductive pad	A low electrical resistance pad for electrostatic prevention measure
Vacuum pressure	Any pressure below the atmospheric pressure. When the atmospheric pressure is used as a reference, the pressure is presented by -kPa (G), and when the absolute pressure is used as a reference, the pressure is represented by kPa (abs). When referencing a piece of vacuum equipment such as an ejector, the pressure is generally represented by -kPa.
Ejector	A unit for generating vacuum by discharging the compressed air from a nozzle at a high speed, based on the phenomenon in which the pressure is reduced when the air around the nozzle is sucked.
Air suction filter	Vacuum filter provided in the vacuum passage for preventing the dust intrusion into the ejector, vacuum pump, or peripheral equipment

# Model Selection

## ● Countermeasures for Vacuum Adsorption System Problems (Troubleshooting)

Condition & Description of improvement	Contributing factor	Countermeasure
Initial adsorption problem (During trial operation)	Adsorption area is small. (Lifting force is lower than the workpiece mass.)	Reconfirm the relationship between workpiece mass and lifting force. <ul style="list-style-type: none"> <li>• Use a vacuum pad with a large adsorption area.</li> <li>• Increase the quantity of vacuum pads.</li> </ul>
	Vacuum pressure is low. (Leakage from adsorption surface) (Air permeable workpiece)	Eliminate (reduce) leakage from adsorption surface. <ul style="list-style-type: none"> <li>• Reconsider shape of vacuum pad.</li> </ul> <p>Confirm the relationship between suction flow rate and arrival pressure of vacuum ejector.</p> <ul style="list-style-type: none"> <li>• Use a vacuum ejector with a high suction flow rate.</li> <li>• Increase adsorption area.</li> </ul>
	Vacuum pressure is low. (Leakage from vacuum piping)	Repair leakage point.
	Internal volume of vacuum circuit is large.	Confirm the relationship between internal volume of the vacuum circuit and suction flow rate of the vacuum ejector. <ul style="list-style-type: none"> <li>• Reduce internal volume of the vacuum circuit.</li> <li>• Use a vacuum ejector with a high suction flow rate.</li> </ul>
	Pressure drop of vacuum piping is large.	Reconsider vacuum piping. <ul style="list-style-type: none"> <li>• Use a shorter or larger tube (with appropriate diameter).</li> </ul>
	Inadequate supply pressure of vacuum ejector	Measure supply pressure in vacuum generation state. <ul style="list-style-type: none"> <li>• Use standard supply pressure.</li> <li>• Reconsider compressed air circuit (line).</li> </ul>
	Clogging of nozzle or diffuser (Infiltration of foreign objects during piping)	Remove foreign objects.
	Supply valve (switching valve) is not being activated.	Measure supply voltage at the solenoid valve with a tester. <ul style="list-style-type: none"> <li>• Review electric circuits, wiring and connectors.</li> <li>• Use in the rated voltage range.</li> </ul>
	Workpiece deforms during adsorption.	Since a workpiece is thin, it deforms and leakage occurs. <ul style="list-style-type: none"> <li>• Use a pad for adsorption of thin objects.</li> </ul>
Late vacuum achieving time (Shortening of response time)	Internal volume of vacuum circuit is large.	Confirm the relationship between internal volume of the vacuum circuit and suction flow rate of the vacuum ejector. <ul style="list-style-type: none"> <li>• Reduce internal volume of the vacuum circuit.</li> <li>• Use a vacuum ejector with a high suction flow rate.</li> </ul>
	Pressure drop of vacuum piping is large.	Reconsider vacuum piping. <ul style="list-style-type: none"> <li>• Use a shorter or larger tube (with appropriate diameter).</li> </ul>
	Using the product as close to the highest vacuum power in the specifications.	Set vacuum pressure to minimum necessary value by optimizing the pad diameter, etc. As the vacuum power of an ejector (venturi) rises, the vacuum flow actually lowers. When an ejector is used at its highest possible vacuum value, the vacuum flow will lower. Due to this, the amount of time needed to achieve adsorption is lengthened. One should consider an increase in the diameter of the ejector nozzle or an increase the size of the vacuum pad utilized in order to lower the required vacuum pressure, maximum the vacuum flow, and speed up the adsorption process.
	Setting of vacuum pressure switch is too high.	Set to suitable setting pressure.

# Model Selection

Condition & Description of improvement	Contributing factor	Countermeasure
Fluctuation in vacuum pressure	Fluctuation in supply pressure	Reconsider compressed air circuit (line). (Addition of a tank, etc.)
	Vacuum pressure may fluctuate under certain conditions due to ejector characteristics.	Lower or raise supply pressure a little at a time, and use in a supply pressure range where vacuum pressure does not fluctuate.
Occurrence of abnormal noise (intermittent noise) from exhaust of vacuum ejector	Intermittent noise may occur under certain conditions due to ejector characteristics.	Lower or raise supply pressure a little at a time, and use in a supply pressure range where the intermittent noise does not occur.
Air leakage from vacuum port of manifold type vacuum ejector	Exhaust air from the ejector enters the vacuum port of another ejector that is stopped.	Use a vacuum ejector with a check valve. (Please contact SMC for the part no. of an ejector with a check valve.)
Adsorption problem over time (Adsorption was normal during trial operation.)	Clogging of suction filter	Replace filters. Improve installation environment.
	Clogging of sound absorbing material	Replace sound absorbing materials. Add a filter to supply (compressed) air circuit. Install an additional suction filter.
	Clogging of nozzle or diffuser	Remove foreign objects. Add a filter to supply (compressed) air circuit. Install an additional suction filter.
	Vacuum pad (rubber) deterioration, cracking, etc.	Replace vacuum pads. Confirm compatibility of vacuum pad material and workpiece.
Workpiece is not released.	Inadequate release flow rate	Open release flow adjustment needle.
	Viscosity increase due to vacuum pad (rubber) wear	Replace vacuum pads. Confirm compatibility of vacuum pad material and workpiece.
	Vacuum pressure is too high.	Set vacuum pressure to minimum necessary value.
	Effects due to static electricity	Use a conductive pad.

# Model Selection

## ●Non-conformance Examples

Phenomenon	Possible causes	Countermeasure
No problem occurred during the test, but adsorption becomes unstable after starting operation.	<ul style="list-style-type: none"> <li>• Setting of the vacuum switch is not appropriate. Supply pressure is unstable. Vacuum pressure does not reach the set pressure.</li> <li>• There is leakage between the workpiece and the vacuum pad.</li> </ul>	<ol style="list-style-type: none"> <li>1) Set the pressure for the vacuum equipment (supply pressure, if using an ejector) to the necessary vacuum pressure during the adsorption of the workpieces. And set the set pressure for the vacuum switch to the necessary vacuum pressure for adsorption.</li> <li>2) It is presumed that there was leakage during the test, but it was not serious enough to prevent adsorption. Revise the vacuum ejector and the shape, diameter, and material of the vacuum pad. Revise the vacuum pad.</li> </ol>
Adsorption becomes unstable after replacing the pad.	<ul style="list-style-type: none"> <li>• Initial setting conditions (vacuum pressure, vacuum switch setting, height of the pad) have changed. Settings have changed because the pad was worn out or had permanent setting due to the operating environment.</li> <li>• When the pad was replaced, leakage was generated from the screw connection part, or the engagement between the pad and the adapter.</li> </ul>	<ol style="list-style-type: none"> <li>1) Revise the operating conditions including vacuum pressure, the set pressure of the vacuum switch, and the height of the pad.</li> <li>2) Revise the engagement.</li> </ol>
Identical pads are used to adsorb identical workpieces, but some of the pads cannot adsorb the workpieces.	<ul style="list-style-type: none"> <li>• There is leakage between the workpiece and the vacuum pad.</li> <li>• The supply circuit for the cylinder, the solenoid valve and the ejector is in the same pneumatic circuit system. The supply pressure decreases when they are used simultaneously. (Vacuum pressure does not increase)</li> <li>• There is leakage from the screw connection part or the engagement between the pad and the adapter.</li> </ul>	<ol style="list-style-type: none"> <li>1) Revise the pad diameter, shape, material, vacuum ejector (suction flow rate), etc.</li> <li>2) Revise the pneumatic circuit.</li> <li>3) Revise the engagement.</li> </ol>
The workpiece cannot be separated from the pad. The workpiece sticks to the rubber part of the bellows.	<ul style="list-style-type: none"> <li>• The adhesiveness of the rubber material is high. Adhesiveness increases due to the operating environment (wearing of the pad, etc.).</li> <li>• Vacuum pressure is higher than necessary, so excessive force (adhesiveness of the rubber + vacuum pressure) is applied to the pad (rubber part).</li> </ul>	<ol style="list-style-type: none"> <li>1) Revise the shape, material, and quantity of vacuum pads.</li> <li>2) Reduce the vacuum pressure. If inadequate lifting force causes a problem in transferring the workpieces due to the reduction of vacuum pressure, increase the number of pads, or select pads with larger diameter.</li> </ol>

■ **When mounted with the nut, sometimes the buffer operation is not smooth, or the buffer does not slide.**

**[Possible causes]**

- The tightening torque of the nut for mounting the buffer is too high.
- Particles stuck to the sliding surface, or it is scratched.
- Lateral load applied to the piston rod, causing eccentric wearing.

**[Remedy]**

Tighten the nut to the recommended tightening torque.

The nut may become loose depending on the operating conditions and environment. Be sure to perform regular maintenance.

**General Purpose**

Product specifications			Nut tightening torque
Pad diameter	Product part no.	Mounting thread size	
ø1.5 to ø3.5	ZP3-*(015 to 035) U*	M6 x 0.75	1.5 to 1.8 N·m
		M8 x 0.75	2.0 to 2.5 N·m
ø4 to ø16	ZP3-*(04 to 16) UM, B* ZP3-*(10 to 16) UM, B*	M8 x 0.75	2.0 to 2.5 N·m

● **Time of Replacement of Vacuum Pad**

**The vacuum pad is disposable. Replace it on a regular basis.**

Continued use of the vacuum pad will cause wear and tear on the adsorption surface, and the exterior dimensions will gradually get smaller and smaller. As the pad diameter gets smaller, lifting force will decrease, though adsorption is possible.

It is extremely difficult to provide advice on the frequency of vacuum pad exchange. This is because there are numerous factors at work, including surface roughness, operating environment (temperature, humidity, ozone, solvents, etc.), and operating conditions (vacuum pressure, workpiece weight, pressing force of the vacuum pad on the workpiece, presence or absence of a buffer, etc.).

Thus, the customer should decide when the vacuum pad should be exchanged, based on its condition at time of initial use.

The bolt may become loose depending on the operating conditions and environment. Be sure to perform regular maintenance.



# Compact Pad

Symbol/Type

U: Flat  
UM: Flat with groove  
B: Bellows

Pad diameter

ø1.5, ø2, ø3.5, ø4, ø6, ø8, ø10, ø13, ø16

## How to Order



Pad unit

ZP3-015 U N

Pad diameter

Symbol	Pad diameter
015	ø1.5
02	ø2
035	ø3.5
04	ø4
06	ø6
08	ø8
10	ø10
13	ø13
16	ø16

Pad material

Symbol	Material
N	NBR
S	Silicone rubber
U	Urethane rubber
F	FKM
GN	Conductive NBR
GS	Conductive silicone rubber

Pad type—Pad diameter

Pad type	Pad diameter (Symbol)								
	015	02	035	04	06	08	10	13	16
U (Flat)	●	●	●	—	—	—	—	—	—
UM (Flat with groove)	—	—	—	●	●	●	●	●	●
B (Bellows)	—	—	—	●	●	●	●	●	●

\* Sales unit  
ø1.5 to ø8 : 10 pcs.  
ø10 to ø16 : 5 pcs.

## Dimensions: Pad Unit

Flat

ZP3-015U □ [Weight: 0.1 g]

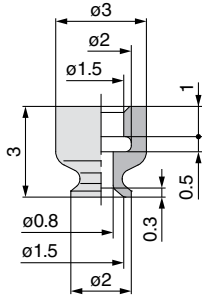

ZP3-02U □ [Weight: 0.1 g]

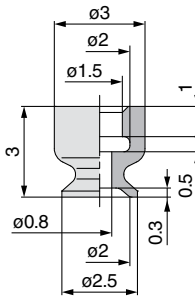

ZP3-035U □ [Weight: 0.1 g]

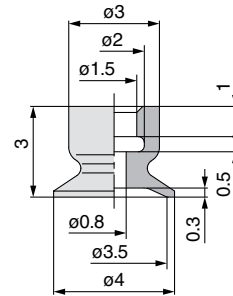

Flat with groove

ZP3-04UM □ [Weight: 0.3 g]

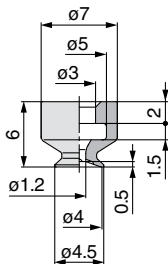

ZP3-06UM □ [Weight: 0.3 g]

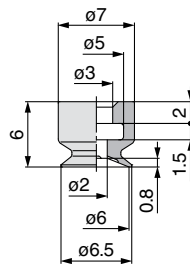

ZP3-08UM □ [Weight: 0.3 g]

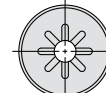
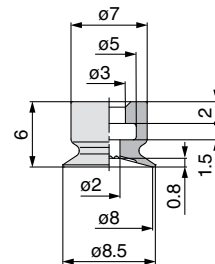

**Dimensions: Pad Unit**

**Flat with groove**

**ZP3-10UM** [Weight: 0.6 g]

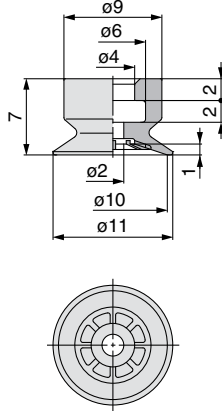

**ZP3-13UM** [Weight: 0.7 g]

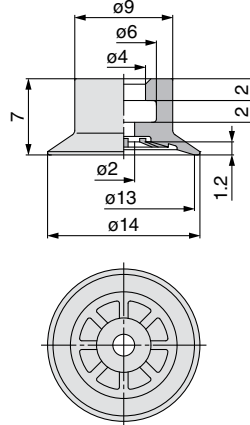

**ZP3-16UM** [Weight: 0.8 g]

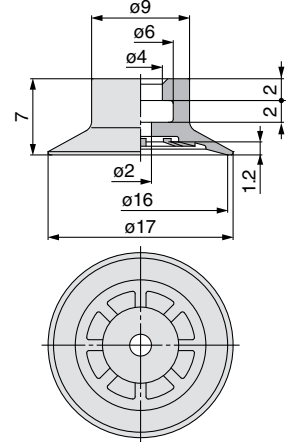

**Bellows**

**ZP3-04B** [Weight: 0.3 g]

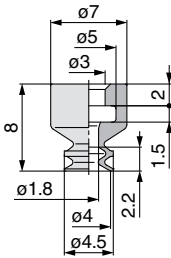

**ZP3-06B** [Weight: 0.3 g]

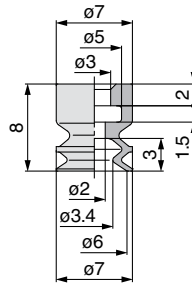

**ZP3-08B** [Weight: 0.4 g]

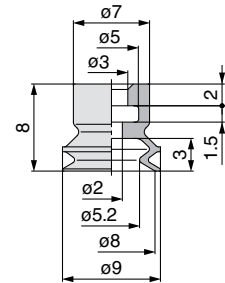

**ZP3-10B** [Weight: 0.8 g]

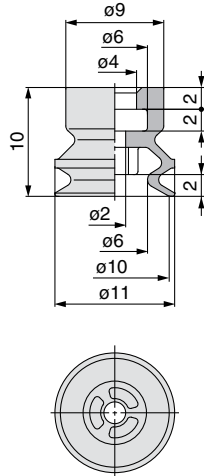

**ZP3-13B** [Weight: 1.0 g]

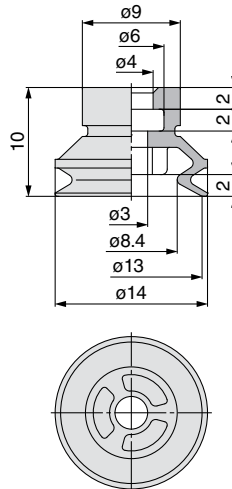

**ZP3-16B** [Weight: 1.1 g]

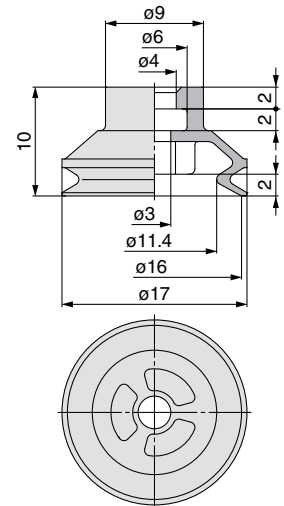

**Pad Mounting Dimensions**

If an adapter will be made by the customer, design the adapter with the dimensions shown below.

**Applicable pad**  
015U/02U/035U

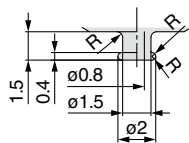

**Applicable pad**  
04UM/06UM/08UM/04B/06B/08B

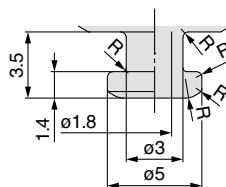

**Applicable pad**  
10UM/13UM/16UM/10B/13B/16B

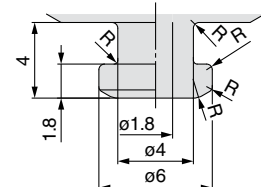

Note) R part has to be smooth with no corners. \*Refer to page 47 and 48 for applicable adapter.

Pad Unit

Vertical  
With Adapter:  
Vacuum Inlet

Vertical  
With Buffer:  
Vacuum Inlet

Lateral  
With Adapter:  
Vacuum Inlet

Lateral  
With Buffer:  
Vacuum Inlet

Construction

Adapter Applicable  
Pad List

Buffer Applicable  
Pad List

Mounting  
Adapter Part No.

Buffer Assembly  
Part No.



## How to Order

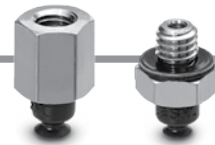

### Vertical vacuum inlet/ With adapter

## ZP3-T 015 U □ N - A6 - B3

#### Vacuum inlet direction

Symbol	Direction
T	Vertical

#### Pad diameter

Symbol	Pad diameter	Symbol	Pad diameter
015	ø1.5	08	ø8
02	ø2	10	ø10
035	ø3.5	13	ø13
04	ø4	16	ø16
06	ø6		

#### Pad type – Pad diameter

Pad type	Pad diameter (Symbol)	015	02	035	04	06
U (Flat)		●	●	●	—	—
UM (Flat with groove)		—	—	—	●	●
B (Bellows)		—	—	—	●	●

Pad type	Pad diameter (Symbol)	08	10	13	16
U (Flat)		—	—	—	—
UM (Flat with groove)		●	●	●	●
B (Bellows)		●	●	●	●

#### Pad material (□)

Symbol	Material
N	NBR
S	Silicone rubber
U	Urethane rubber
F	FKM
GN	Conductive NBR
GS	Conductive silicone rubber

#### Vacuum inlet (◇)

Symbol	Vacuum inlet	Mounting thread size		
		A6	A10	A12
B3	M3 x 0.5 female thread	●	—	—
B5	M5 x 0.8 female thread	—	—	●
U2	ø2 tubing/barb fitting *1	●	●	●
U4	ø4 tubing/barb fitting *2	●	●	●
U6	ø6 tubing/barb fitting *2	—	—	●
02	ø2 tubing	●	●	●
04	ø4 tubing	●	●	●
06	ø6 tubing	—	—	●
Nil	—	A3/A5/B3/B5		

\*1 Polyurethane tube piping

\*2 Soft nylon/Polyurethane tube piping

#### Mounting thread size

	Symbol	Mounting Thread size	ø1.5 to ø3.5	ø4 to ø8	ø10 to ø16
Male thread	A3*	M3 x 0.5	●	—	—
	A5*	M5 x 0.8	—	●	●
	A6	M6 x 0.75	●	—	—
	A10	M10 x 1	—	●	—
	A12	M12 x 1	—	—	●
Female thread	B3*	M3 x 0.5	●	—	—
	B5*	M5 x 0.8	—	●	●

\* indicates vacuum inlet symbol is "Nil".

## Replacement Part No.

### Pad diameter: ø1.5 to ø3.5

Model	Pad unit part no.	Adapter part no.
ZP3-T (015/02/035) U□-A3	ZP3-(015/02/035)U□	ZP3A-T1-A3
ZP3-T (015/02/035) U□-B3		ZP3A-T1-B3
ZP3-T (015/02/035) U□-A6-◇		ZP3A-T1-A6-B3

Note 1) □ in the table indicates the pad material.

Note 2) ◇ in the table indicates the vacuum inlet.

Note 3) Fitting is ordered separately.

Suffix of how to order (◇) U2: M-3AU-2, U4: M-3AU-4-X83  
02: KJH02-M3, 04: KJH04-M3-X83

### Pad diameter: ø4 to ø8

Model	Pad unit part no.	Adapter part no.
ZP3-T (04/06/08) UM□-A5	ZP3-(04/06/08) UM□	ZP3A-T2-A5
ZP3-T (04/06/08) B□-A5	ZP3-(04/06/08) B□	
ZP3-T (04/06/08) UM□-B5	ZP3-(04/06/08) UM□	ZP3A-T2-B5
ZP3-T (04/06/08) B□-B5	ZP3-(04/06/08) B□	
ZP3-T (04/06/08) UM□-A10-◇	ZP3-(04/06/08) UM□	ZP3A-T2-A10-B5
ZP3-T (04/06/08) B□-A10-◇	ZP3-(04/06/08) B□	
ZP3-T (04/06/08) UM□-A10-04	ZP3-(04/06/08) UM□	
ZP3-T (04/06/08) B□-A10-04	ZP3-(04/06/08) B□	

Note 1) □ in the table indicates the pad material.

Note 2) ◇ in the table indicates the vacuum inlet.

Note 3) Fitting is ordered separately.

Suffix of how to order (◇) U2: M-5AU-2, U4: M-5AU-4-X83,  
02: KJH02-M5

### Pad diameter: ø10 to ø16

Model	Pad unit part no.	Adapter part no.
ZP3-T (10/13/16) UM□-A5	ZP3-(10/13/16) UM□	ZP3A-T3-A5
ZP3-T (10/13/16) B□-A5	ZP3-(10/13/16) B□	
ZP3-T (10/13/16) UM□-B5	ZP3-(10/13/16) UM□	ZP3A-T3-B5
ZP3-T (10/13/16) B□-B5	ZP3-(10/13/16) B□	
ZP3-T (10/13/16) UM□-A12-◇	ZP3-(10/13/16) UM□	ZP3A-T3-A12-B5
ZP3-T (10/13/16) B□-A12-◇	ZP3-(10/13/16) B□	
ZP3-T (10/13/16) UM□-A12-04	ZP3-(10/13/16) UM□	
ZP3-T (10/13/16) B□-A12-04	ZP3-(10/13/16) B□	
ZP3-T (10/13/16) UM□-A12-06	ZP3-(10/13/16) UM□	ZP3A-T3-A12-06
ZP3-T (10/13/16) B□-A12-06	ZP3-(10/13/16) B□	

Note 1) □ in the table indicates the pad material.

Note 2) ◇ in the table indicates the vacuum inlet.

Note 3) Fitting is ordered separately.

Suffix of how to order (◇) U2: M-5AU-2, U4: M-5AU-4-X83  
U6: M-5AU-6-X83, 02: KJH02-M5

## Dimensions/With Adapter: Vacuum Inlet **Vertical**

Pad diameter ø1.5 to ø3.5

Pad type Flat

### ZP3-T015U□-A3

[Weight: 0.6 g]

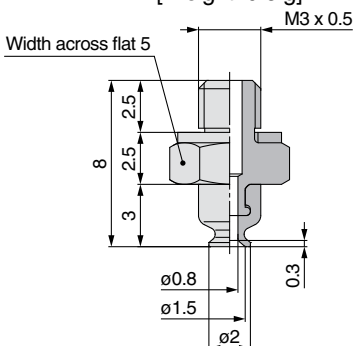

### ZP3-T02U□-A3

[Weight: 0.6 g]

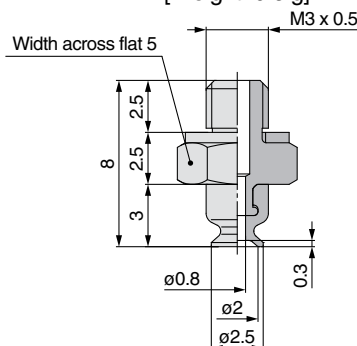

### ZP3-T035U□-A3

[Weight: 0.6 g]

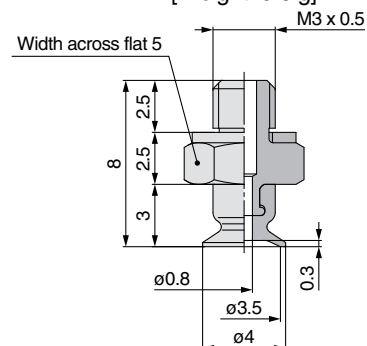

Pad diameter  $\phi 1.5$  to  $\phi 3.5$

Pad type Flat

Dimensions/With Adapter: Vacuum Inlet **Vertical**

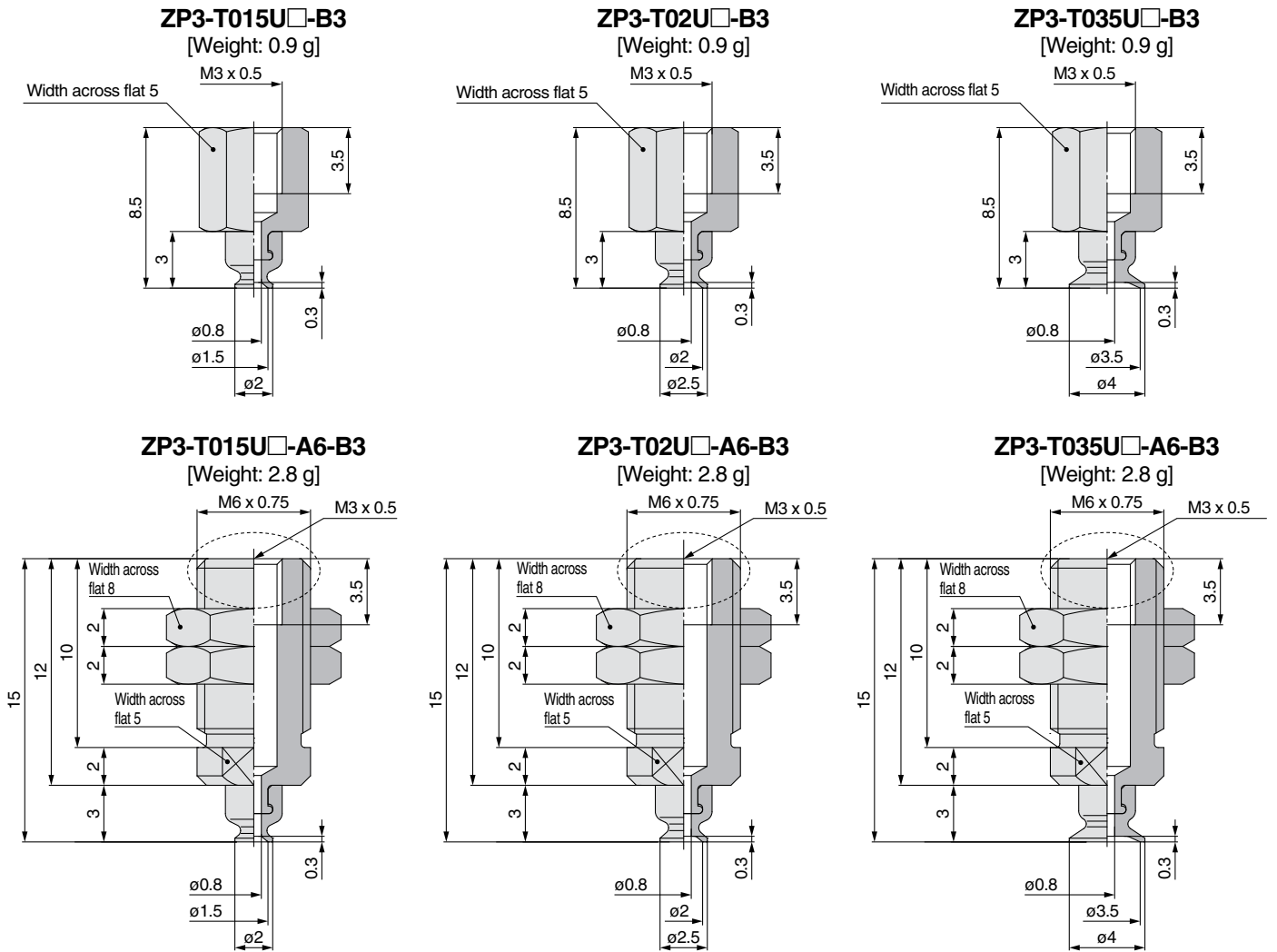

Vacuum Inlet Dimensions

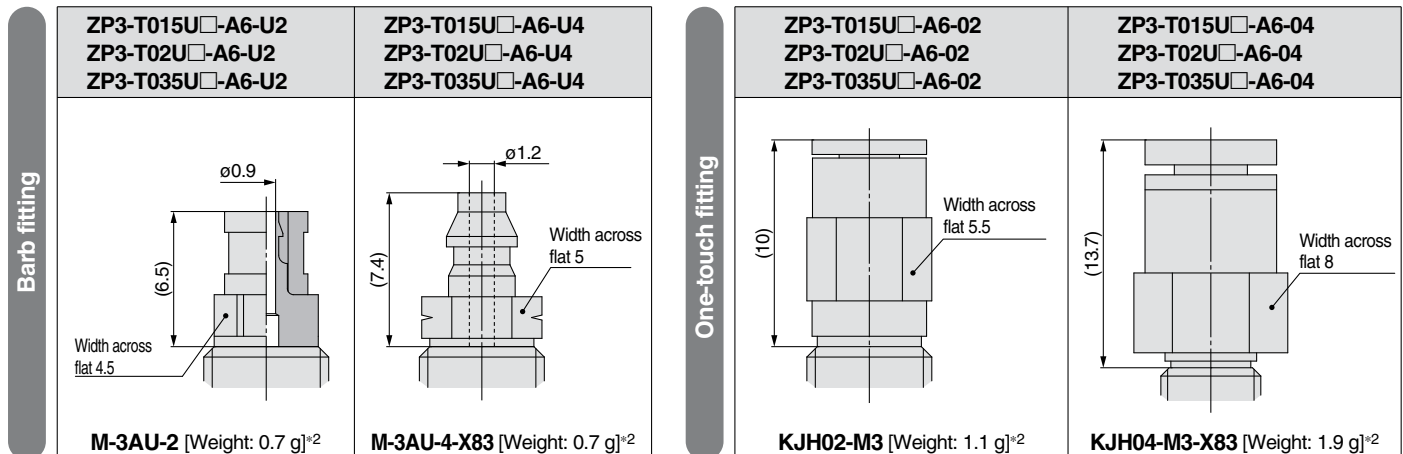

\*1 Refer to "ZP3-T▲▲▲U-A6-B3" for dimensions.

\*2 When calculating the weight, add the weight of the fitting to "ZP3-T▲▲▲U-A6-B3".

Pad Unit  
Vertical  
With Adapter: Vacuum Inlet  
Vertical  
With Buffer: Vacuum Inlet  
Lateral  
With Adapter: Vacuum Inlet  
Lateral  
With Buffer: Vacuum Inlet  
Construction  
Adapter Applicable Pad List  
Buffer Applicable Pad List  
Mounting Adapter Part No.  
Buffer Assembly Part No.

# Series ZP3

Dimensions/With Adapter: Vacuum Inlet

**Vertical**

Pad diameter  $\phi 4$  to  $\phi 8$

Pad type Flat with groove

**ZP3-T04UM□-A5**  
[Weight: 1.7 g]

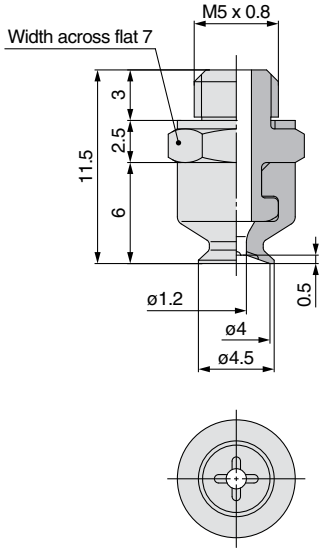

**ZP3-T06UM□-A5**  
[Weight: 1.7 g]

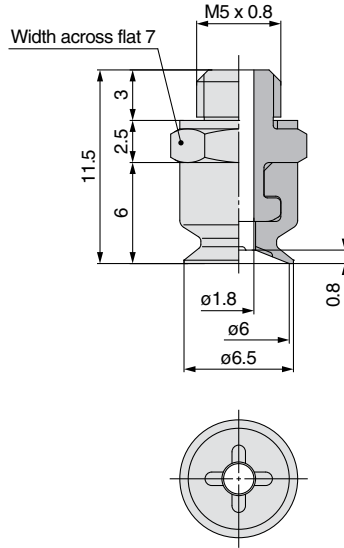

**ZP3-T08UM□-A5**  
[Weight: 1.7 g]

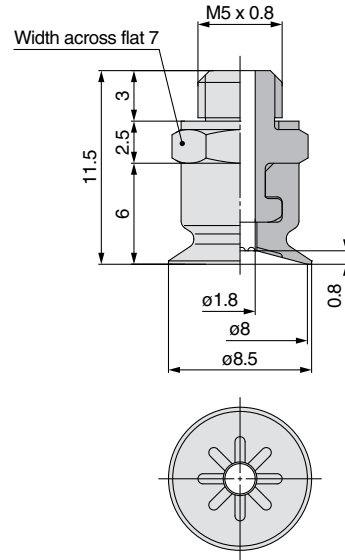

**ZP3-T04UM□-B5**  
[Weight: 2.3 g]

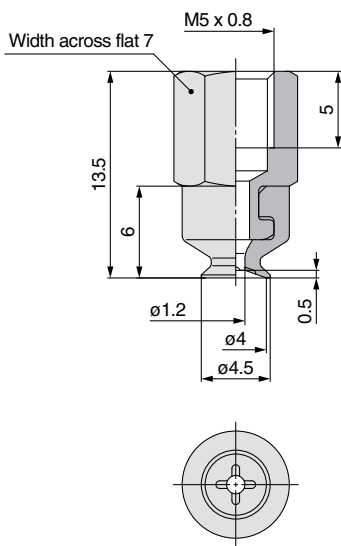

**ZP3-T06UM□-B5**  
[Weight: 2.3 g]

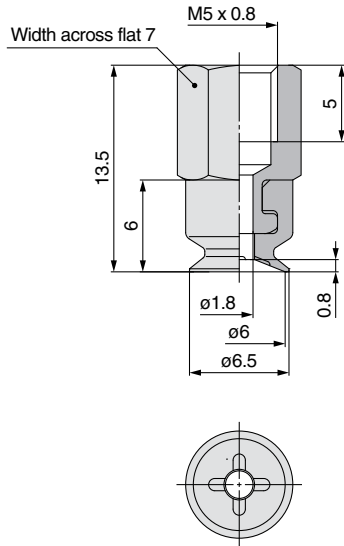

**ZP3-T08UM□-B5**  
[Weight: 2.3 g]

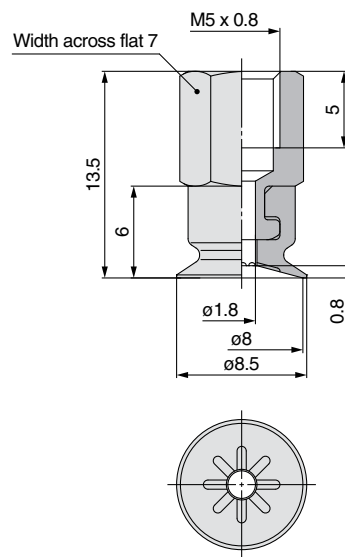

Dimensions/With Adapter: Vacuum Inlet **Vertical**

Pad diameter  $\phi 4$  to  $\phi 8$   
 Pad type Flat with groove

**ZP3-T04UM□-A10-B5**  
 [Weight: 11.0 g]

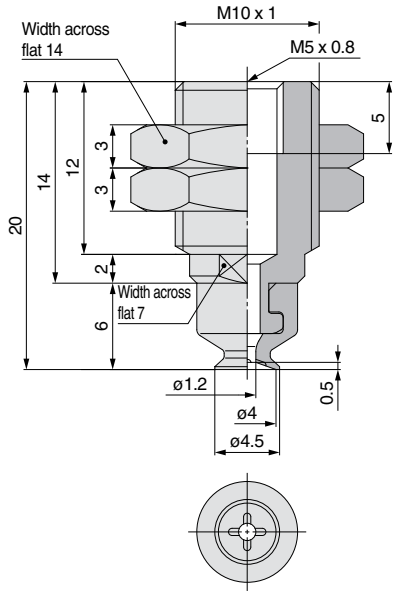

**ZP3-T06UM□-A10-B5**  
 [Weight: 11.0 g]

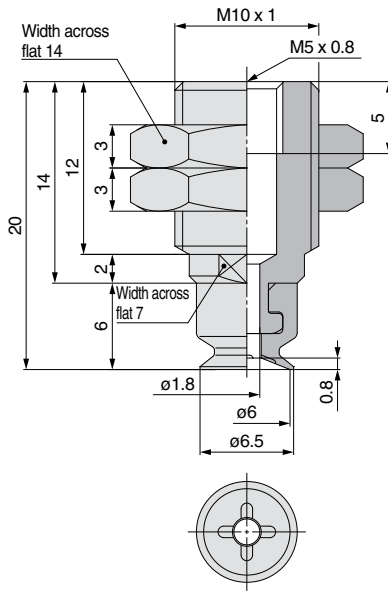

**ZP3-T08UM□-A10-B5**  
 [Weight: 11.0 g]

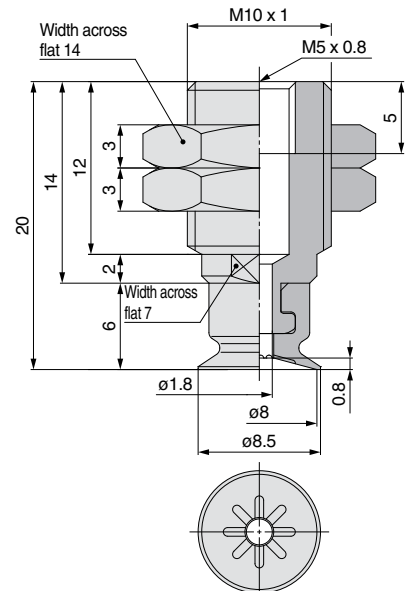

**Vacuum Inlet Dimensions**

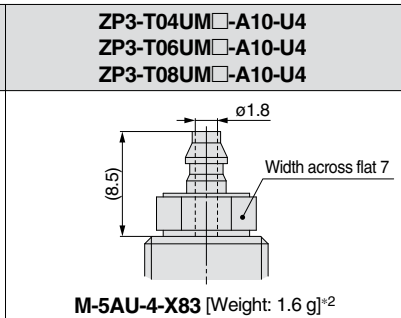
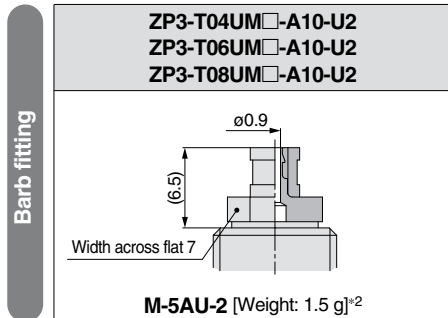

\*1 Refer to "ZP3-T▲▲UM□-A10-B5" for dimensions.  
 \*2 When calculating the weight, add the weight of the fitting to "ZP3-T▲▲UM□-A10-B5".

**ZP3-T04UM□-A10-04**  
 [Weight: 10.2 g]  
 Applicable tubing:  $\phi 4$

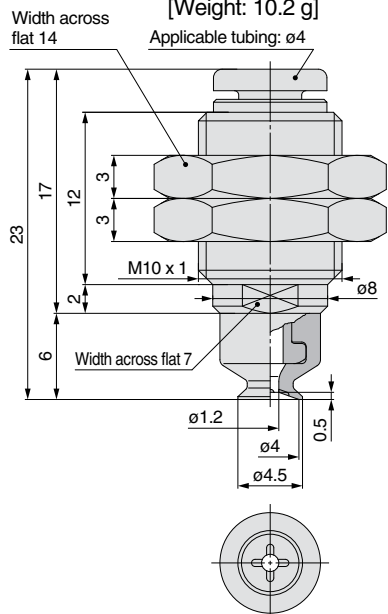

**ZP3-T06UM□-A10-04**  
 [Weight: 10.2 g]  
 Applicable tubing:  $\phi 4$

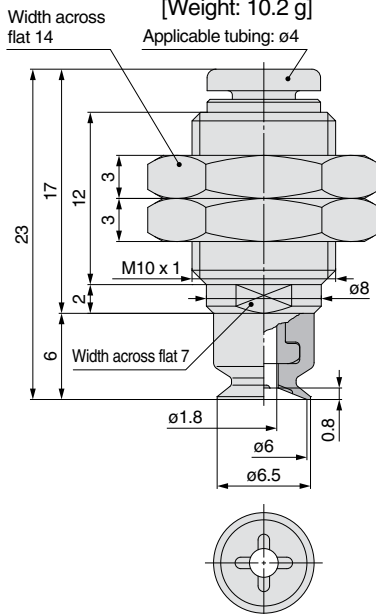

**ZP3-T08UM□-A10-04**  
 [Weight: 10.2 g]  
 Applicable tubing:  $\phi 4$

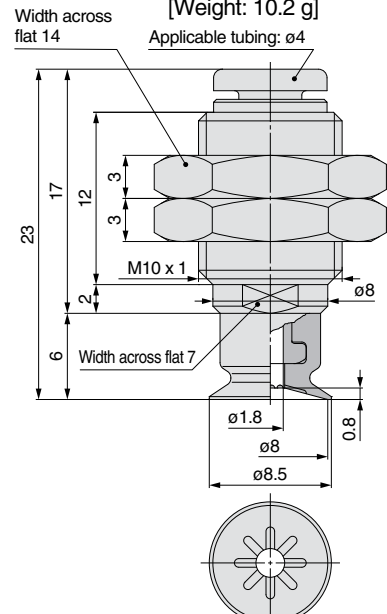

Pad Unit  
 Vertical  
 With Adapter: Vacuum Inlet  
 Vertical  
 With Buffer: Vacuum Inlet  
 Lateral  
 With Adapter: Vacuum Inlet  
 Lateral  
 With Buffer: Vacuum Inlet  
 Construction  
 Adapter Applicable Pad List  
 Buffer Applicable Pad List  
 Mounting Adapter Part No.  
 Buffer Assembly Part No.

Pad diameter  $\phi 10$  to  $\phi 16$

Pad type Flat with groove

## Dimensions/With adapter: Vacuum inlet **Vertical**

**ZP3-T10UM□-A5**  
[Weight: 3.0 g]

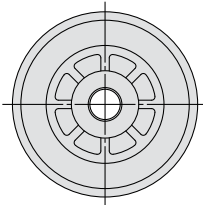
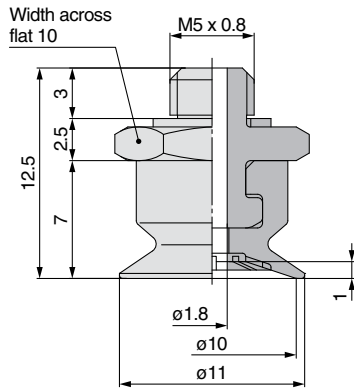

**ZP3-T13UM□-A5**  
[Weight: 3.1 g]

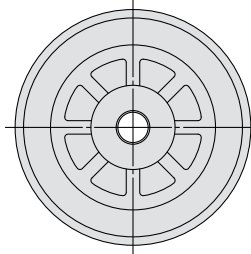
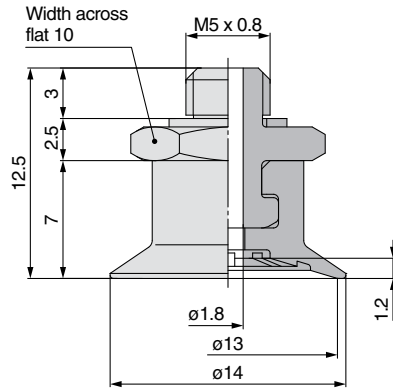

**ZP3-T16UM□-A5**  
[Weight: 3.2 g]

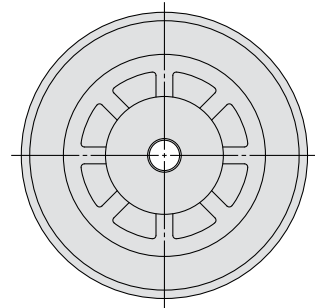
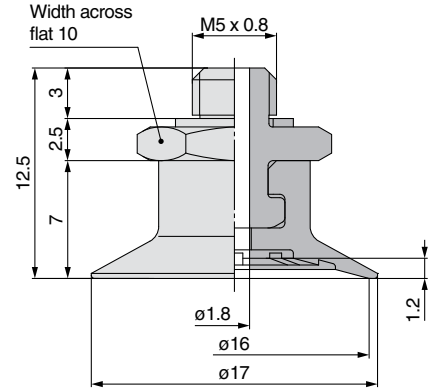

**ZP3-T10UM□-B5**  
[Weight: 5.7 g]

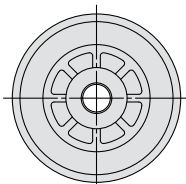
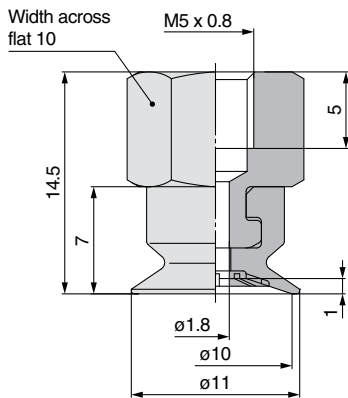

**ZP3-T13UM□-B5**  
[Weight: 5.8 g]

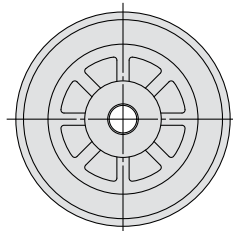
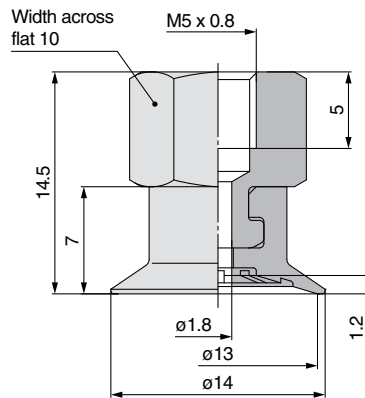

**ZP3-T16UM□-B5**  
[Weight: 5.9 g]

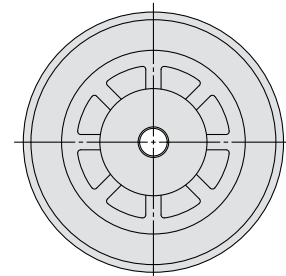
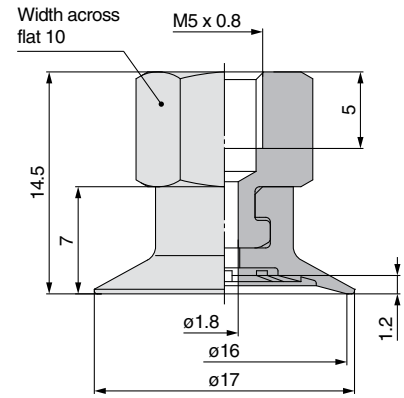

Dimensions/With Adapter: Vacuum Inlet **Vertical**

Pad diameter  $\phi 10$  to  $\phi 16$   
Pad type Flat with groove

ZP3-T10UM□-A12-B5

[Weight: 18.8 g]

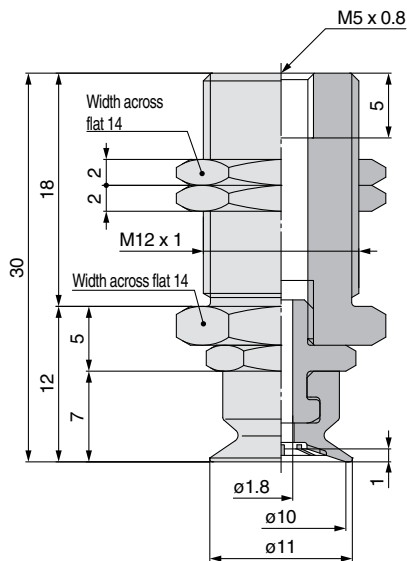

ZP3-T13UM□-A12-B5

[Weight: 18.9 g]

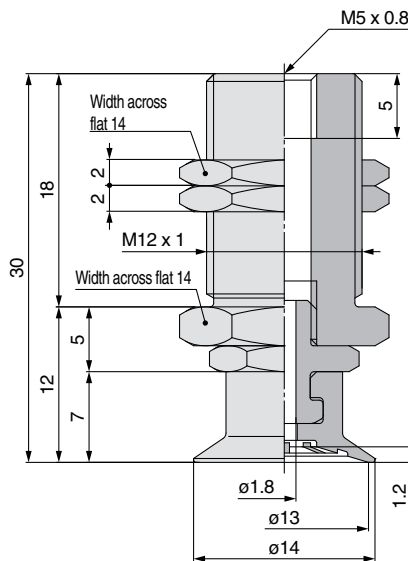

ZP3-T16UM□-A12-B5

[Weight: 19.0 g]

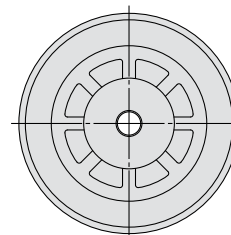
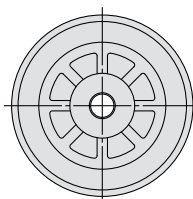
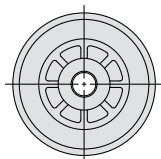
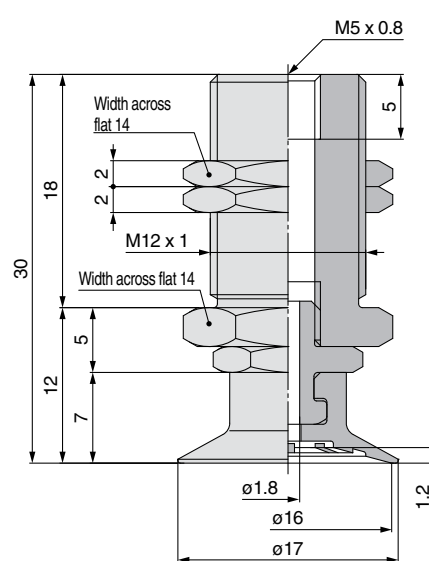

Vacuum Inlet Dimensions

	ZP3-T10UM□-A12-U2 ZP3-T13UM□-A12-U2 ZP3-T16UM□-A12-U2	ZP3-T10UM□-A12-U4 ZP3-T13UM□-A12-U4 ZP3-T16UM□-A12-U4	ZP3-T10UM□-A12-U6 ZP3-T13UM□-A12-U6 ZP3-T16UM□-A12-U6
<b>Barb fitting</b>	<p>M-5AU-2 [Weight: 1.5 g]<sup>*2</sup></p>	<p>M-5AU-4-X83 [Weight: 1.6 g]<sup>*2</sup></p>	<p>M-5AU-6-X83 [Weight: 1.8 g]<sup>*2</sup></p>
<b>One-touch fitting</b>	<p>KJH02-M5 [Weight: 1.9 g]<sup>*2</sup></p>		

\*1 Refer to "ZP3-T▲▲UM□-A12-B5" for dimensions.

\*2 When calculating the weight, add the weight of the fitting to "ZP3-T▲▲UM□-A12-B5".

Pad Unit  
Vertical  
With Adapter: Vacuum Inlet  
Vertical  
With Buffer: Vacuum Inlet  
Lateral  
With Adapter: Vacuum Inlet  
Lateral  
With Buffer: Vacuum Inlet  
Construction  
Adapter Applicable Pad List  
Buffer Applicable Pad List  
Mounting Adapter Part No.  
Buffer Assembly Part No.

## Dimensions/With Adapter: Vacuum Inlet

## Vertical

Pad diameter  $\phi 10$  to  $\phi 16$

Pad type Flat with groove

**ZP3-T10UM□-A12-04**

[Weight: 20.2 g]

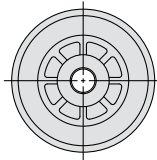
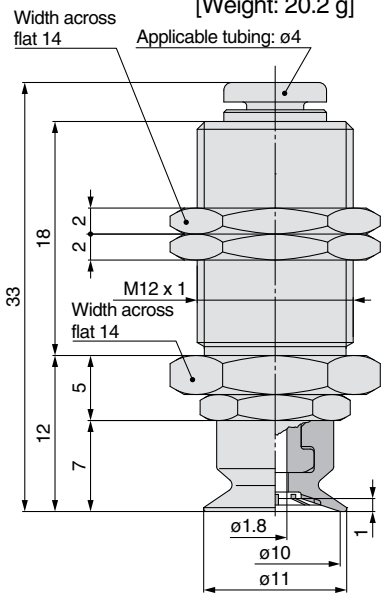

**ZP3-T13UM□-A12-04**

[Weight: 20.3 g]

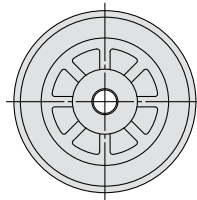
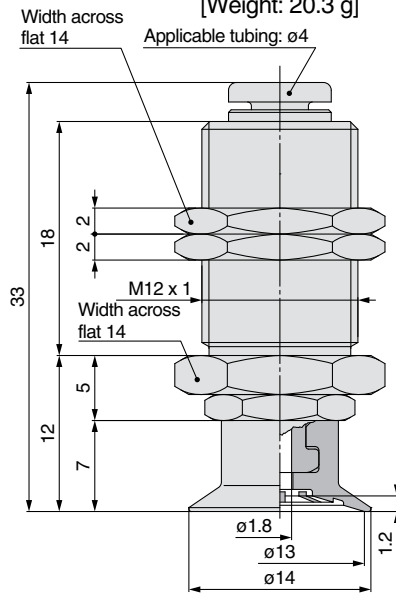

**ZP3-T16UM□-A12-04**

[Weight: 20.4 g]

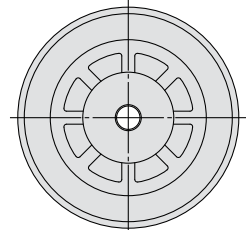
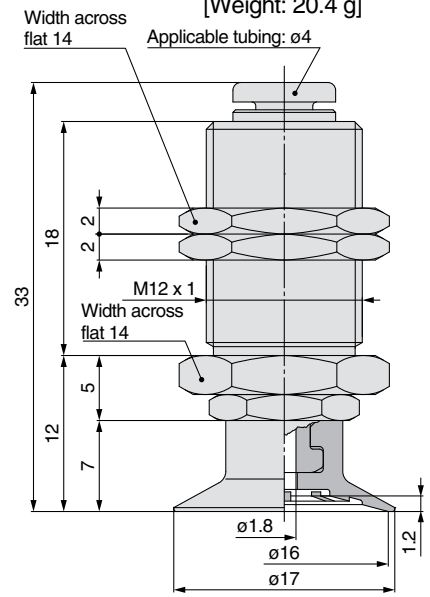

**ZP3-T10UM□-A12-06**

[Weight: 18.1 g]

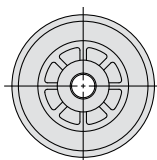
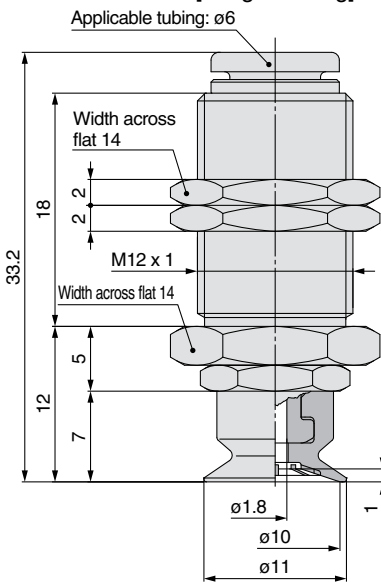

**ZP3-T13UM□-A12-06**

[Weight: 18.2 g]

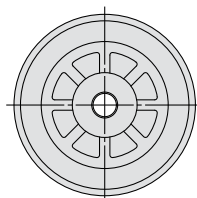
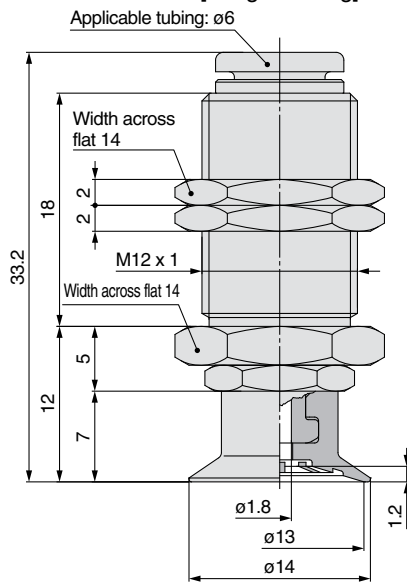

**ZP3-T16UM□-A12-06**

[Weight: 18.3 g]

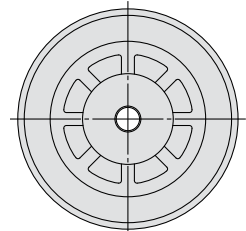
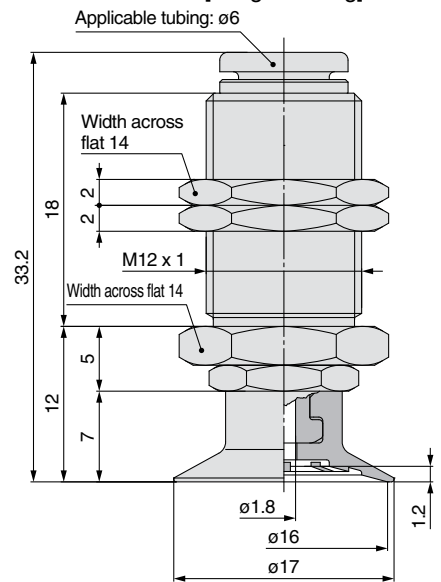



Dimensions/With Adapter: Vacuum Inlet

**Vertical**

Pad diameter  $\phi 4$  to  $\phi 8$

Pad type Bellows

**ZP3-T04B□-A5**  
[Weight: 1.7 g]

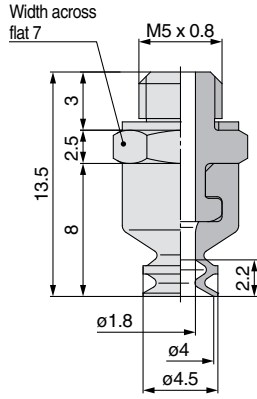

**ZP3-T06B□-A5**  
[Weight: 1.7 g]

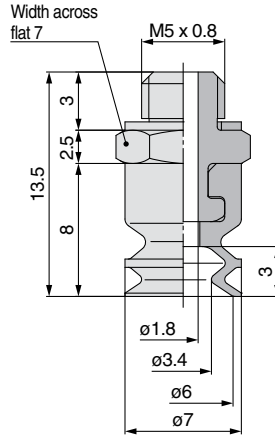

**ZP3-T08B□-A5**  
[Weight: 1.8 g]

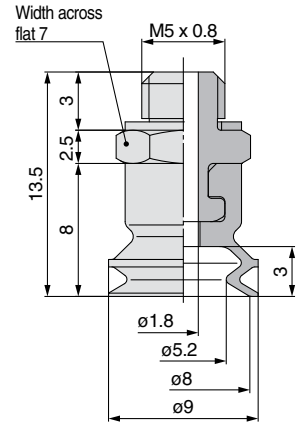

**ZP3-T04B□-B5**  
[Weight: 2.3 g]

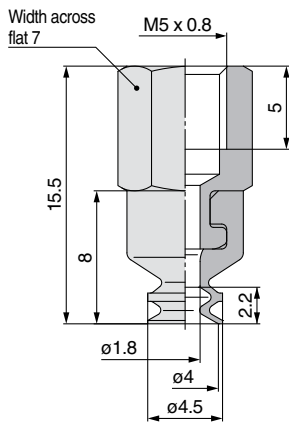

**ZP3-T06B□-B5**  
[Weight: 2.3 g]

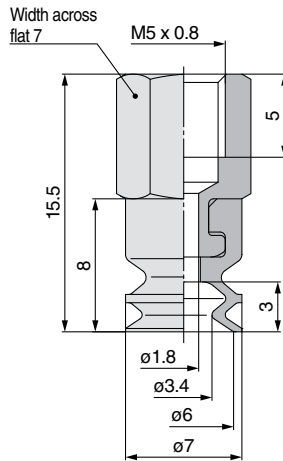

**ZP3-T08B□-B5**  
[Weight: 2.4 g]

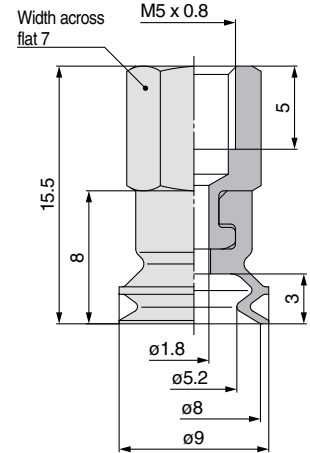

Pad Unit

Vertical  
With Adapter:  
Vacuum Inlet

Vertical  
With Buffer:  
Vacuum Inlet

Lateral  
With Adapter:  
Vacuum Inlet

Lateral  
With Buffer:  
Vacuum Inlet

Construction

Adapter Applicable  
Pad List

Buffer Applicable  
Pad List

Mounting Adapter  
Part No.

Buffer Assembly  
Part No.

Pad diameter  $\phi 4$  to  $\phi 8$   
 Pad type Bellows

## Dimensions/With Adapter: Vacuum Inlet **Vertical**

**ZP3-T04B□-A10-B5**  
 [Weight: 11.0 g]

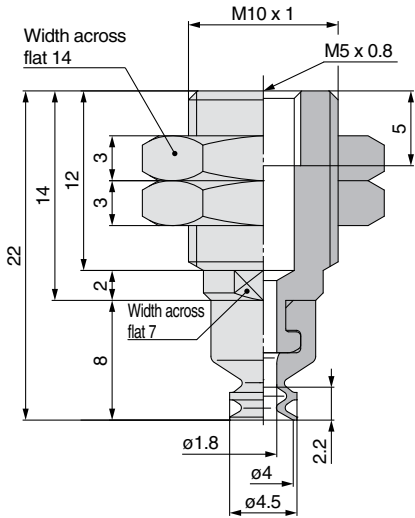

**ZP3-T06B□-A10-B5**  
 [Weight: 11.0 g]

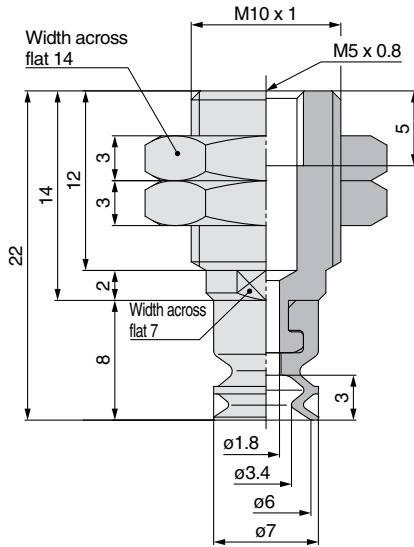

**ZP3-T08B□-A10-B5**  
 [Weight: 11.1 g]

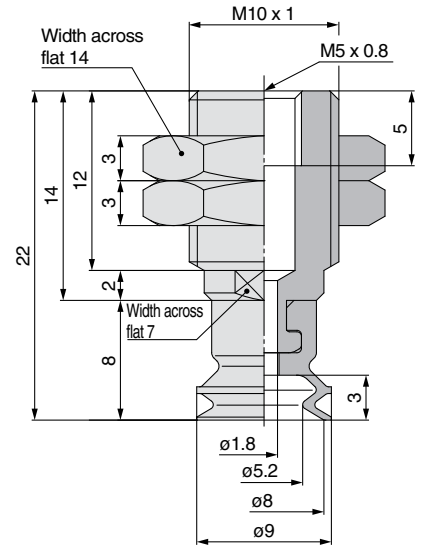

### Vacuum Inlet Dimensions

Barb fitting	<p><b>ZP3-T04B□-A10-U2</b>  <b>ZP3-T06B□-A10-U2</b>  <b>ZP3-T08B□-A10-U2</b></p> <p><b>M-5AU-2</b> [Weight: 1.5 g]*2</p>	<p><b>ZP3-T04B□-A10-U4</b>  <b>ZP3-T06B□-A10-U4</b>  <b>ZP3-T08B□-A10-U4</b></p> <p><b>M-5AU-4-X83</b> [Weight: 1.6 g]*2</p>
	<p><b>One-touch fitting</b></p> <p><b>KJH02-M5</b> [Weight: 1.8 g]*2</p>	

\*1 Refer to "ZP3-T▲▲B■-A10-B5" for dimensions.

\*2 When calculating the weight, add the weight of the fitting to "ZP3-T▲▲B■-A10-B5".

**ZP3-T04B□-A10-04**  
 [Weight: 10.2 g]

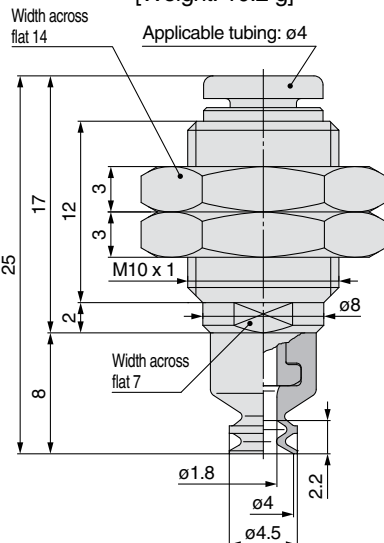

**ZP3-T06B□-A10-04**  
 [Weight: 10.2 g]

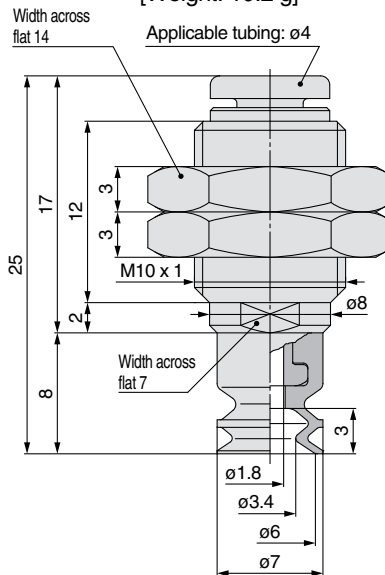

**ZP3-T08B□-A10-04**  
 [Weight: 10.3 g]

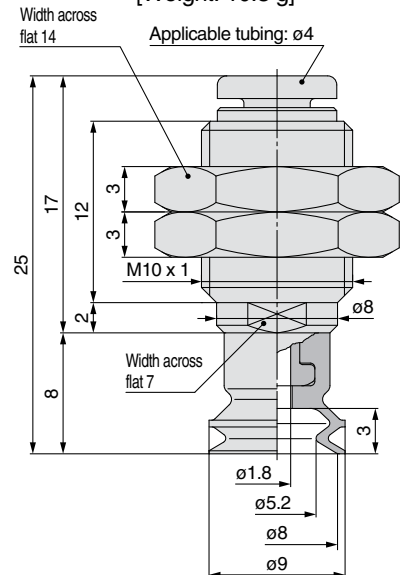

Pad diameter  $\varnothing 10$  to  $\varnothing 16$

Pad type **Bellows**

Dimensions/With Adapter: Vacuum Inlet **Vertical**

**ZP3-T10B□-A5**  
[Weight: 3.2 g]

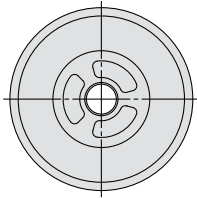
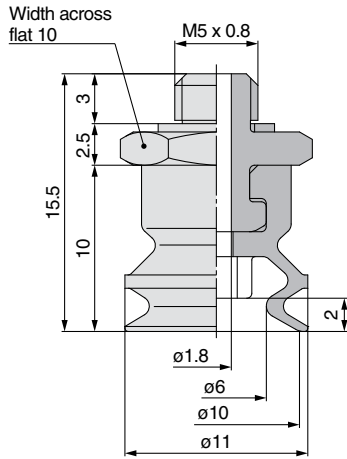

**ZP3-T13B□-A5**  
[Weight: 3.4 g]

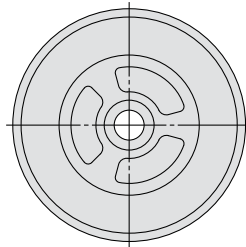
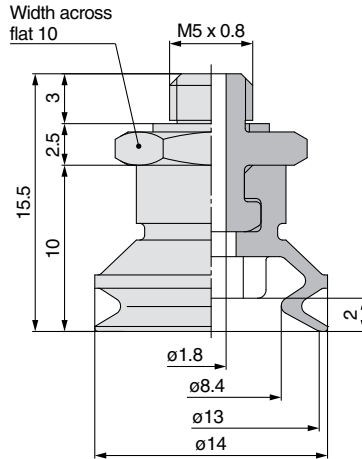

**ZP3-T16B□-A5**  
[Weight: 3.5 g]

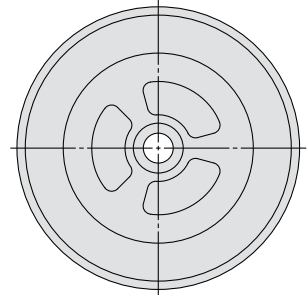
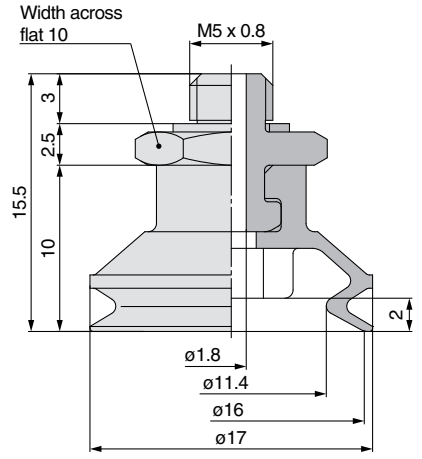

**ZP3-T10B□-B5**  
[Weight: 5.9 g]

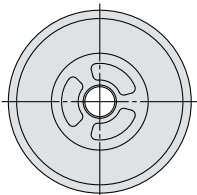
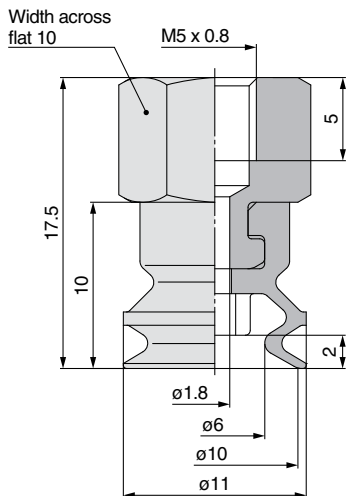

**ZP3-T13B□-B5**  
[Weight: 6.1 g]

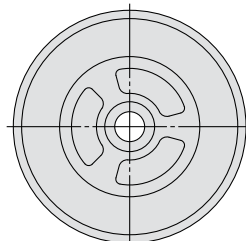
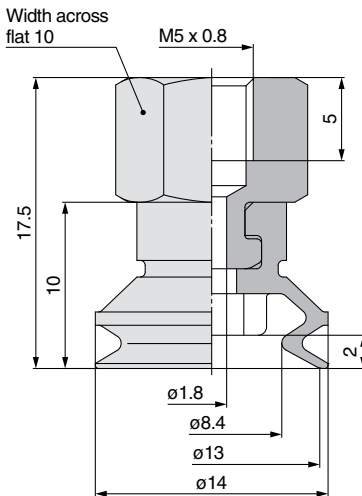

**ZP3-T16B□-B5**  
[Weight: 6.2 g]

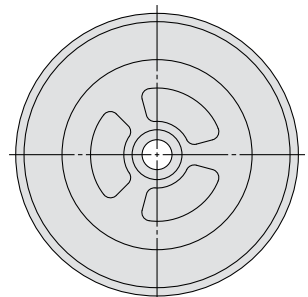
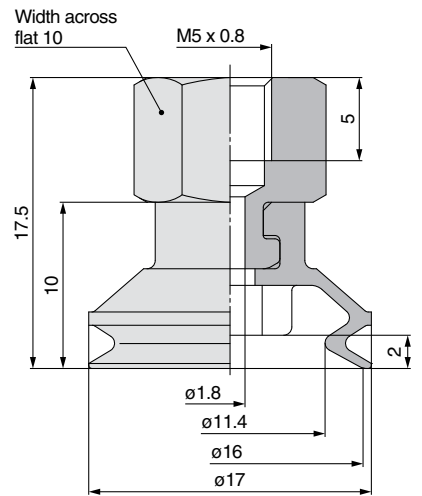

ZP3-T10B□-A12-B5

[Weight: 19.0 g]

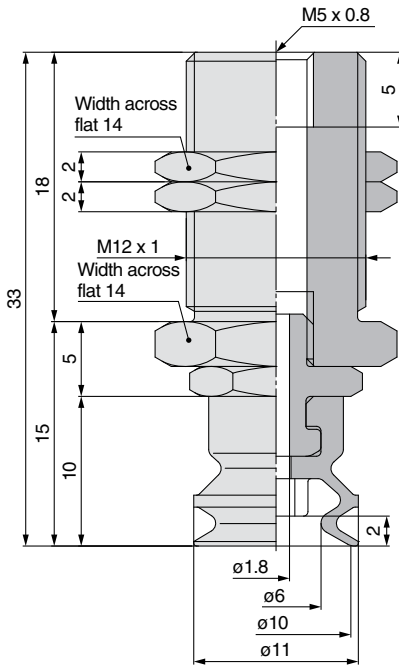

ZP3-T13B□-A12-B5

[Weight: 19.2 g]

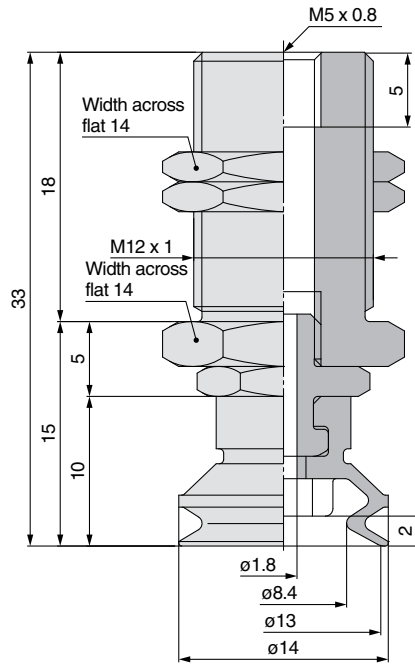

ZP3-T16B□-A12-B5

[Weight: 19.3 g]

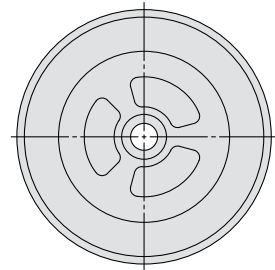
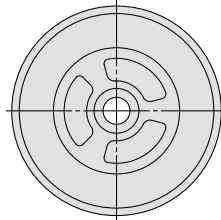
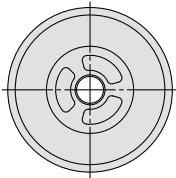
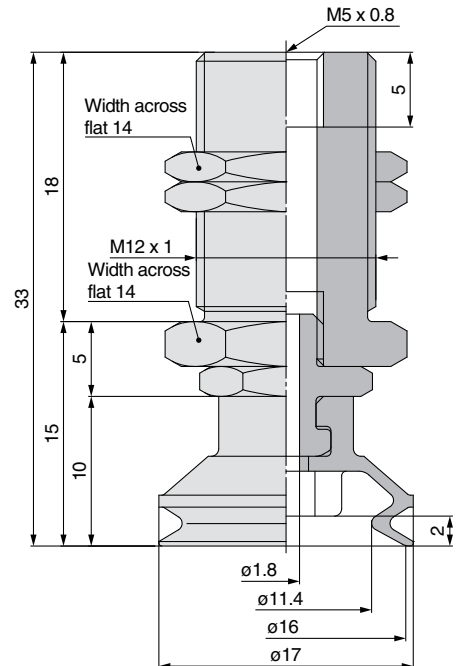

### Vacuum Inlet Dimensions

	ZP3-T10B□-A12-U2 ZP3-T13B□-A12-U2 ZP3-T16B□-A12-U2	ZP3-T10B□-A12-U4 ZP3-T13B□-A12-U4 ZP3-T16B□-A12-U4	ZP3-T10B□-A12-U6 ZP3-T13B□-A12-U6 ZP3-T16B□-A12-U6
Barb fitting	<p>M-5AU-2 [Weight: 1.5 g]*<sup>2</sup></p>	<p>M-5AU-4-X83 [Weight: 1.6 g]*<sup>2</sup></p>	<p>M-5AU-6-X83 [Weight: 1.8 g]*<sup>2</sup></p>

	ZP3-T10B□-A12-02 ZP3-T13B□-A12-02 ZP3-T16B□-A12-02
One-touch fitting	<p>KJH02-M5 [Weight: 1.9 g]*<sup>2</sup></p>

\* 1 Refer to "ZP3-T▲▲B□-A12-B5" for dimensions.

\* 2 When calculating the weight, add the weight of the fitting to "ZP3-T▲▲B□-A12-B5".

Pad diameter  $\phi 10$  to  $\phi 16$

Pad type **Bellows**

Dimensions/With Adapter: Vacuum Inlet **Vertical**

**ZP3-T10B-A12-04**

[Weight: 20.4 g]

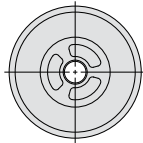
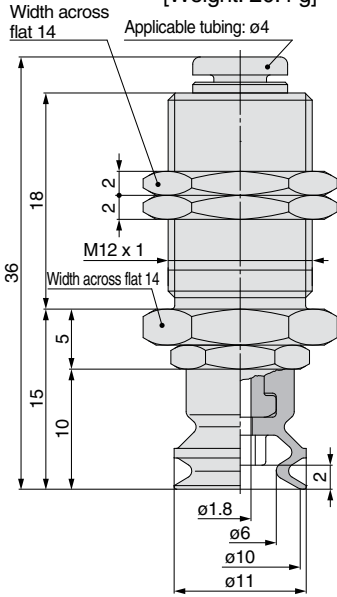

**ZP3-T13B-A12-04**

[Weight: 20.6 g]

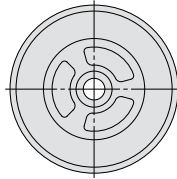
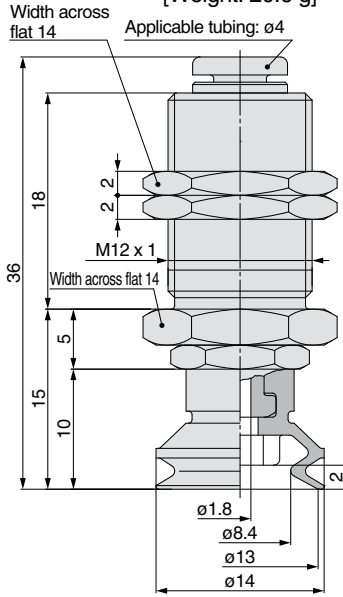

**ZP3-T16B-A12-04**

[Weight: 20.7 g]

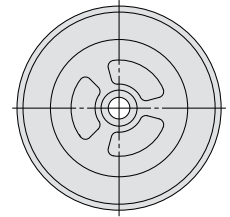
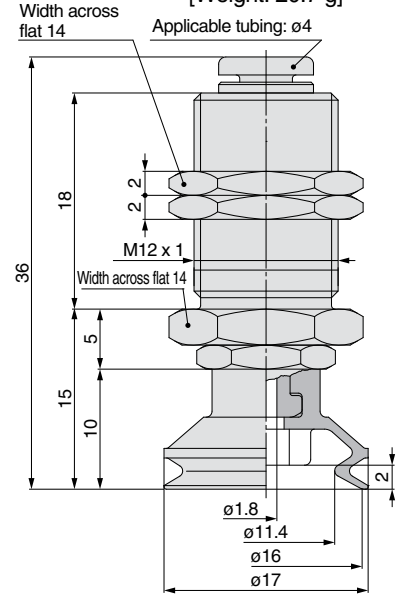

**ZP3-T10B-A12-06**

[Weight: 18.3 g]

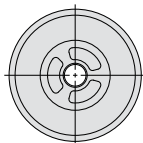
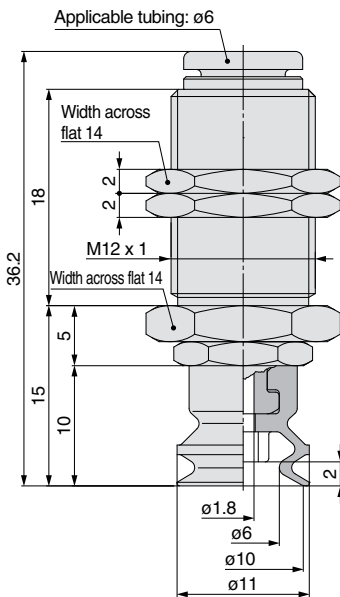

**ZP3-T13B-A12-06**

[Weight: 18.5 g]

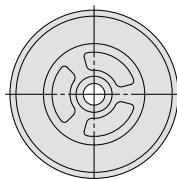
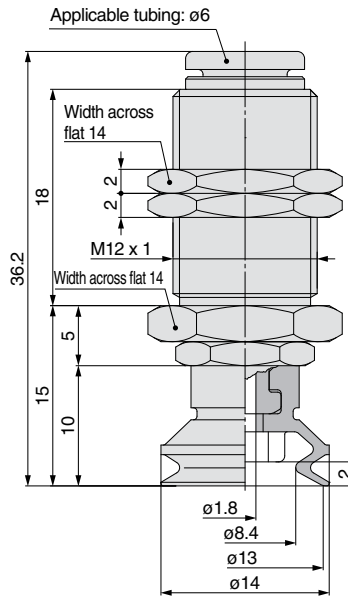

**ZP3-T16B-A12-06**

[Weight: 18.6 g]

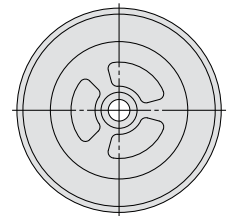
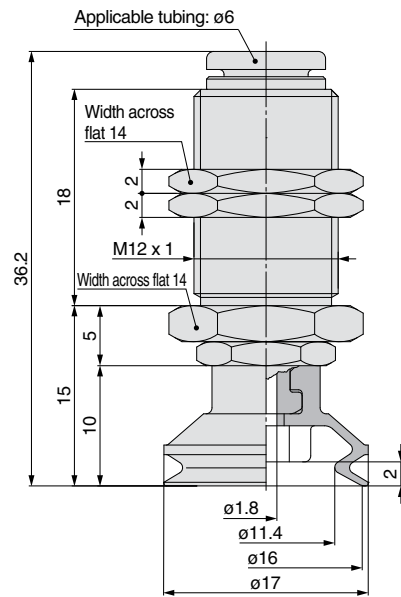

Vertical	With Adapter: Vacuum Inlet	Vertical	With Buffer: Vacuum Inlet	Lateral	With Adapter: Vacuum Inlet	Lateral	With Buffer: Vacuum Inlet
Construction							
Adapter Applicable Pad List							
Buffer Applicable Pad List							
Mounting Adapter Part No.							
Buffer Assembly Part No.							

## How to Order

Vertical vacuum inlet/  
With buffer

### ZP3-T 015 U N J 3 - B3

Vacuum inlet direction ●

Symbol	Direction
T	Vertical

Pad diameter ●

Symbol	Pad diameter
015	ø1.5
02	ø2
035	ø3.5
04	ø4
06	ø6
08	ø8
10	ø10
13	ø13
16	ø16

Pad type – Pad diameter ●

Pad type	Pad diameter (Symbol)				
	015	02	035	04	06
U (Flat)	●	●	●	●	●
UM (Flat with groove)	—	—	—	—	●
B (Bellows)	—	—	—	●	●

Pad type	Pad diameter (Symbol)			
	08	10	13	16
U (Flat)	—	—	—	—
UM (Flat with groove)	●	●	●	●
B (Bellows)	●	●	●	●

Pad material (□) ●

Symbol	Material
N	NBR
S	Silicone rubber
U	Urethane rubber
F	FKM
GN	Conductive NBR
GS	Conductive silicone rubber

Vacuum inlet (◇)

	Symbol	Connection	ø1.5 to ø3.5	ø4 to ø8	ø10 to ø16
			●	●	●
Female thread	B3	M3 x 0.5	●	—	—
	B5	M5 x 0.8	—	●	●
Barb fitting	U2	ø2 tubing *1	●	●	●
	U4	ø4 tubing *2	●	●	●
	U6	ø6 tubing *2	—	—	●
One-touch fitting	02	ø2 tubing	●	●	●
	04	ø4 tubing	●	●	●
	06	ø6 tubing	—	—	●

\*1 Polyurethane tube piping

\*2 Soft nylon/Polyurethane tube piping

Stroke (■)—Buffer specifications

Stroke	ø1.5 to ø3.5		ø4 to ø16		
	J	K	J	JB	K
3	●	●	●	—	●
6	●	●	●	—	●
10	—	—	●	—	●
15	—	—	—	●	●
20	—	—	—	●	●

\*Refer to the "Specifications" below, for applicable stroke.

Buffer specifications (☆)

J	Rotating
JB	Rotating, With bushing
K	Non-rotating

## Specifications

Pad diameter	Buffer specifications	Stroke (mm)	Tightening torque lbf-ft (N-m)	Mounting	Spring reactive force	
					At 0 stroke lbf (N)	At full stroke lbf (N)
ø1.5 to ø3.5	J	3, 6	1.1 to 1.33 (1.5 to 1.8)	M6 x 0.75	0.045 (0.2)	0.09 (0.4)
	K					
ø4 to ø16	J	3, 6, 10	1.48 to 1.84 (2.0 to 2.5)	M8 x 0.75	0.045 (0.2)	0.11 (0.5)
	JB					
	K					
	K					

## Replacement Part No.

Pad diameter: ø1.5 to ø3.5

Model	Pad unit part no.	Buffer assembly part no. (Note 3)
ZP3-T(015/02/035)U□(J/K)3-◇	ZP3-(015/02/035)U□	ZP3B-T1(J/K)3-B3
ZP3-T(015/02/035)U□(J/K)6-◇	ZP3-(015/02/035)U□	ZP3B-T1(J/K)6-B3

Note 1) □ in the table indicates the pad material.

Note 2) ◇ in the table indicates the vacuum inlet.

Note 3) Fitting is ordered separately.

Suffix of how to order (◇) U2: M-3AU-2, U4: M-3AU-4-X83  
02: KJH02-M3, 04: KJH04-M3-X83

Pad diameter: ø4 to ø8

Model	Pad unit part no.	Buffer assembly part no. (Note 3)
ZP3-T(04/06/08)UM□(J/K)3-◇	ZP3-(04/06/08)UM□	ZP3B-T2A(J/K)3-B5
ZP3-T(04/06/08)B□(J/K)3-◇	ZP3-(04/06/08)B□	ZP3B-T2A(J/K)3-B5
ZP3-T(04/06/08)UM□(J/K)6-◇	ZP3-(04/06/08)UM□	ZP3B-T2A(J/K)6-B5
ZP3-T(04/06/08)B□(J/K)6-◇	ZP3-(04/06/08)B□	ZP3B-T2A(J/K)6-B5
ZP3-T(04/06/08)UM□(J/K)10-◇	ZP3-(04/06/08)UM□	ZP3B-T2A(J/K)10-B5
ZP3-T(04/06/08)B□(J/K)10-◇	ZP3-(04/06/08)B□	ZP3B-T2A(J/K)10-B5
ZP3-T(04/06/08)UM□(JB/K)15-◇	ZP3-(04/06/08)UM□	ZP3B-T2A(JB/K)15-B5
ZP3-T(04/06/08)B□(JB/K)15-◇	ZP3-(04/06/08)B□	ZP3B-T2A(JB/K)15-B5
ZP3-T(04/06/08)UM□(JB/K)20-◇	ZP3-(04/06/08)UM□	ZP3B-T2A(JB/K)20-B5
ZP3-T(04/06/08)B□(JB/K)20-◇	ZP3-(04/06/08)B□	ZP3B-T2A(JB/K)20-B5

Note 1) □ in the table indicates the pad material.

Note 2) ◇ in the table indicates the vacuum inlet.

Note 3) Fitting is ordered separately.

Suffix of how to order (◇) U2: M-5AU-2, U4: M-5AU-4-X83  
02: KJH02-M5, 04: KJH04-M5

Pad diameter: ø10 to ø16

Model	Pad unit part no.	Buffer assembly part no. (Note 3)
ZP3-T(10/13/16)UM□(J/K)3-◇	ZP3-(10/13/16)UM□	ZP3B-T2B(J/K)3-B5
ZP3-T(10/13/16)B□(J/K)3-◇	ZP3-(10/13/16)B□	ZP3B-T2B(J/K)3-B5
ZP3-T(10/13/16)UM□(J/K)6-◇	ZP3-(10/13/16)UM□	ZP3B-T2B(J/K)6-B5
ZP3-T(10/13/16)B□(J/K)6-◇	ZP3-(10/13/16)B□	ZP3B-T2B(J/K)6-B5
ZP3-T(10/13/16)UM□(J/K)10-◇	ZP3-(10/13/16)UM□	ZP3B-T2B(J/K)10-B5
ZP3-T(10/13/16)B□(J/K)10-◇	ZP3-(10/13/16)B□	ZP3B-T2B(J/K)10-B5
ZP3-T(10/13/16)UM□(JB/K)15-◇	ZP3-(10/13/16)UM□	ZP3B-T2B(JB/K)15-B5
ZP3-T(10/13/16)B□(JB/K)15-◇	ZP3-(10/13/16)B□	ZP3B-T2B(JB/K)15-B5
ZP3-T(10/13/16)UM□(JB/K)20-◇	ZP3-(10/13/16)UM□	ZP3B-T2B(JB/K)20-B5
ZP3-T(10/13/16)B□(JB/K)20-◇	ZP3-(10/13/16)B□	ZP3B-T2B(JB/K)20-B5

Note 1) □ in the table indicates the pad material.

Note 2) ◇ in the table indicates the vacuum inlet.

Note 3) Fitting is ordered separately.

Suffix of how to order (◇) U2: M-5AU-2, U4: M-5AU-4-X83  
U6: M-5AU-6-X83, 02: KJH02-M5  
04: KJH04-M5, 06: KJH06-M5

Pad diameter  $\phi 1.5$  to  $\phi 3.5$

Pad type **Flat**

Stroke **3, 6 mm**

**Dimensions/With Buffer: Vacuum Inlet Vertical**

ZP3-T015U□J■-B3

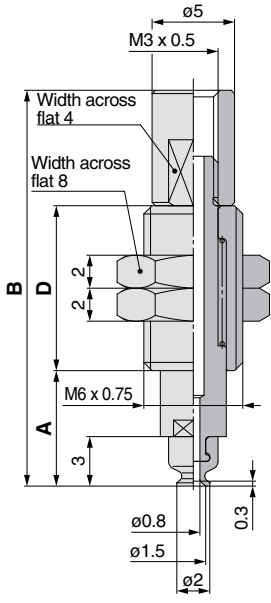

ZP3-T015U□K■-B3

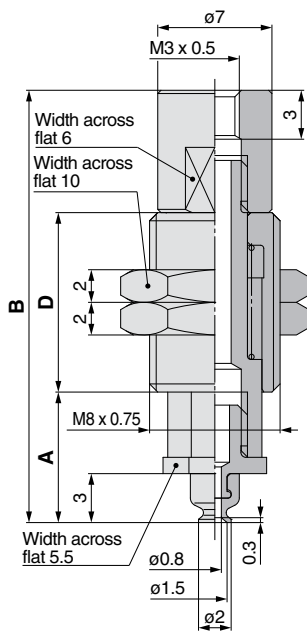

ZP3-T02U□J■-B3

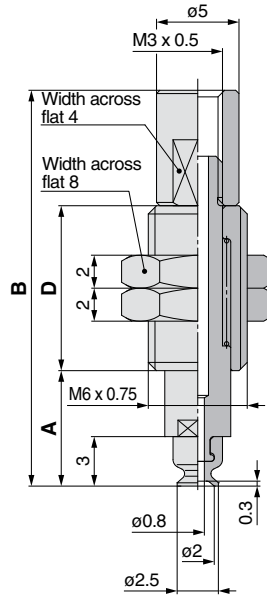

ZP3-T02U□K■-B3

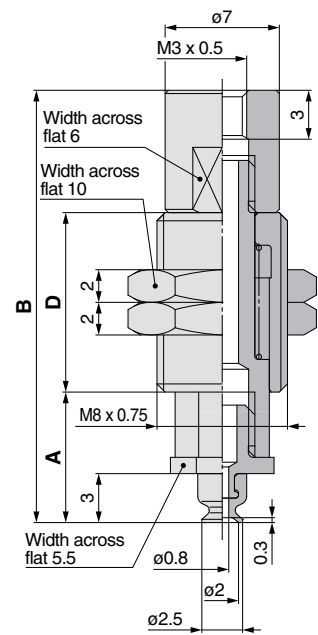

**Dimensions (per stroke)**

Model	A	B	D	Weight (g)
ZP3-T015U□J3-B3	7	24	10	3.4
ZP3-T015U□J6-B3	10	31	14	4.4

Note) □ in the table indicates the pad material "N, S, U, F, GN, GS."

**Dimensions (per stroke)**

Model	A	B	D	Weight (g)
ZP3-T015U□K3-B3	8	26.5	11	6.8
ZP3-T015U□K6-B3	11	33	14.5	8.2

Note) □ in the table indicates the pad material "N, S, U, F, GN, GS."

**Dimensions (per stroke)**

Model	A	B	D	Weight (g)
ZP3-T02U□J3-B3	7	24	10	3.4
ZP3-T02U□J6-B3	10	31	14	4.4

Note) □ in the table indicates the pad material "N, S, U, F, GN, GS."

**Dimensions (per stroke)**

Model	A	B	D	Weight (g)
ZP3-T02U□K3-B3	8	26.5	11	6.8
ZP3-T02U□K6-B3	11	33	14.5	8.2

Note) □ in the table indicates the pad material "N, S, U, F, GN, GS."

ZP3-T035U□J■-B3

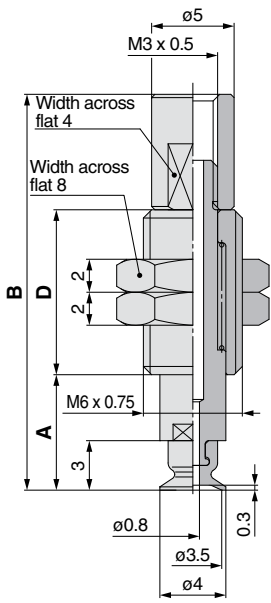

ZP3-T035U□K■-B3

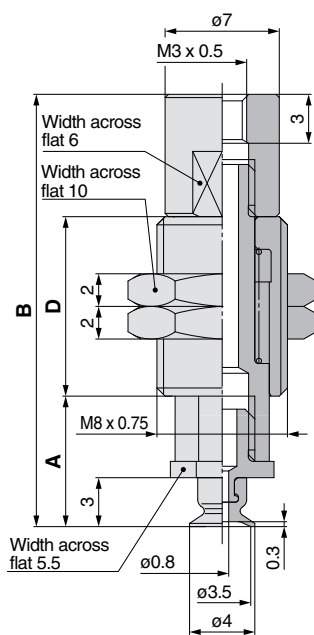

**Dimensions (per stroke)**

Model	A	B	D	Weight (g)
ZP3-T035U□J3-B3	7	24	10	3.4
ZP3-T035U□J6-B3	10	31	14	4.4

Note) □ in the table indicates the pad material "N, S, U, F, GN, GS."

**Dimensions (per stroke)**

Model	A	B	D	Weight (g)
ZP3-T035U□K3-B3	8	26.5	11	6.8
ZP3-T035U□K6-B3	11	33	14.5	8.2

Note) □ in the table indicates the pad material "N, S, U, F, GN, GS."

**Vacuum Inlet Dimensions**

**Barb fitting**

ZP3-T015U□☆■-U2  
ZP3-T02U□☆■-U2  
ZP3-T035U□☆■-U2

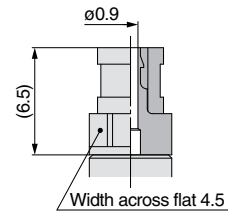

M-3AU-2 [Weight: 0.7 g]<sup>\*2</sup>

ZP3-T015U□☆■-U4  
ZP3-T02U□☆■-U4  
ZP3-T035U□☆■-U4

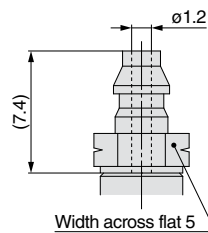

M-3AU-4-X83 [Weight: 0.7 g]<sup>\*2</sup>

**One-touch fitting**

ZP3-T015U□☆■-02  
ZP3-T02U□☆■-02  
ZP3-T035U□☆■-02

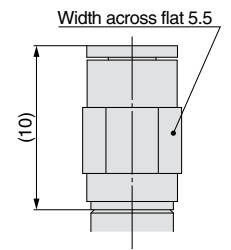

KJH02-M3 [Weight: 1.1 g]<sup>\*2</sup>

ZP3-T015U□☆■-04  
ZP3-T02U□☆■-04  
ZP3-T035U□☆■-04

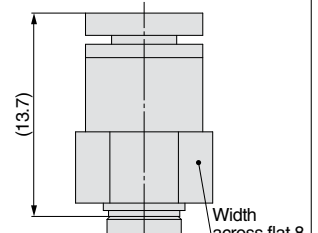

KJH04-M3-X83 [Weight: 1.9 g]<sup>\*2</sup>

\*1 Refer to "ZP3-T▲▲▲U□☆■-B3" for dimensions.

\*2 When calculating the weight, add the weight of the fitting to "ZP3-T▲▲▲U□☆■-B3".



Pad diameter  $\phi 4$  to  $\phi 8$

Pad type Flat with groove

Stroke 3, 6, 10 mm

## Dimensions/With Buffer: Vacuum Inlet **Vertical**

ZP3-T04UM□J■■■-B5

ZP3-T04UM□K■■■-B5

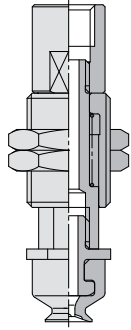
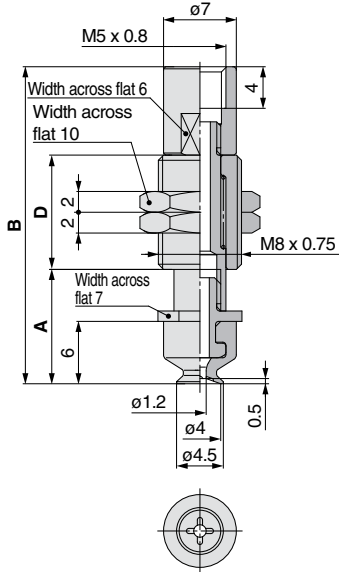

ZP3-T06UM□J■■■-B5

ZP3-T06UM□K■■■-B5

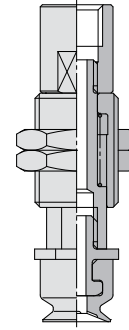
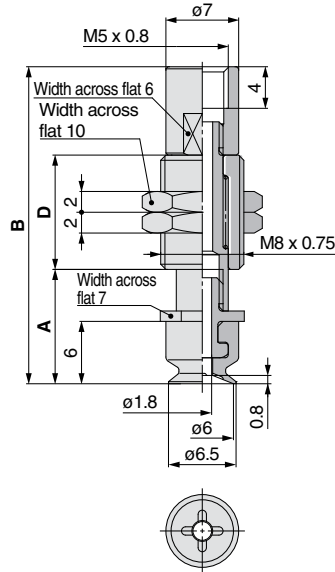

Dimensions (per stroke)

Model	A	B	D	Weight (g)	
				Non-rotating (J)	Rotating (K)
ZP3-T04UM□☆3-B5	11	30.5	11	7.4	7.3
ZP3-T04UM□☆6-B5	14	37	14.5	8.6	8.6
ZP3-T04UM□☆10-B5	18	47	20.5	10.5	10.5

Note 1) □ in the table indicates the pad material "N, S, U, F, GN, GS."  
 Note 2) The symbol "☆" indicates buffer type "J" or "K".

Dimensions (per stroke)

Model	A	B	D	Weight (g)	
				Non-rotating (J)	Rotating (K)
ZP3-T06UM□☆3-B5	11	30.5	11	7.4	7.3
ZP3-T06UM□☆6-B5	14	37	14.5	8.6	8.6
ZP3-T06UM□☆10-B5	18	47	20.5	10.5	10.5

Note 1) □ in the table indicates the pad material "N, S, U, F, GN, GS."  
 Note 2) The symbol "☆" indicates buffer type "J" or "K".

ZP3-T08UM□J■■■-B5

ZP3-T08UM□K■■■-B5

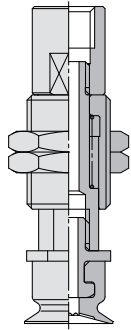
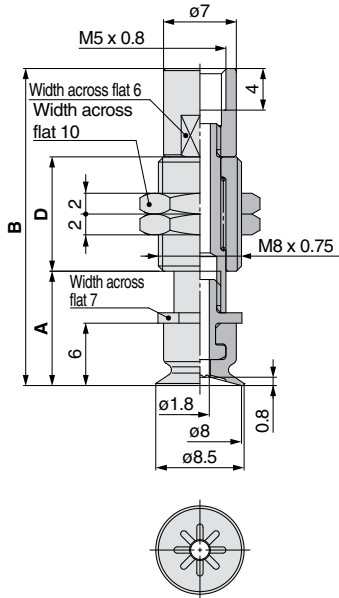

Dimensions (per stroke)

Model	A	B	D	Weight (g)	
				Non-rotating (J)	Rotating (K)
ZP3-T08UM□☆3-B5	11	30.5	11	7.4	7.3
ZP3-T08UM□☆6-B5	14	37	14.5	8.6	8.6
ZP3-T08UM□☆10-B5	18	47	20.5	10.5	10.5

Note 1) □ in the table indicates the pad material "N, S, U, F, GN, GS."  
 Note 2) The symbol "☆" indicates buffer type "J" or "K".

## Vacuum Inlet Dimensions

### Barb fitting

ZP3-T04UM□☆■■■-U2  
 ZP3-T06UM□☆■■■-U2  
 ZP3-T08UM□☆■■■-U2

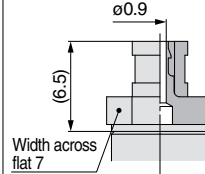

M-5AU-2 [Weight: 1.5 g]\*2

ZP3-T04UM□☆■■■-U4  
 ZP3-T06UM□☆■■■-U4  
 ZP3-T08UM□☆■■■-U4

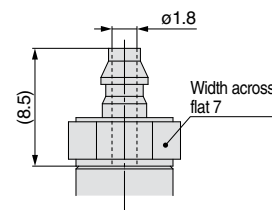

M-5AU-4-X83 [Weight: 1.6 g]\*2

### One-touch fitting

ZP3-T04UM□☆■■■-02  
 ZP3-T06UM□☆■■■-02  
 ZP3-T08UM□☆■■■-02

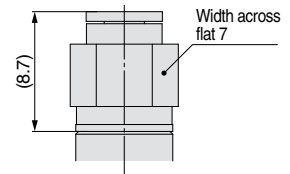

KJH02-M5 [Weight: 1.9 g]\*2

ZP3-T04UM□☆■■■-04  
 ZP3-T06UM□☆■■■-04  
 ZP3-T08UM□☆■■■-04

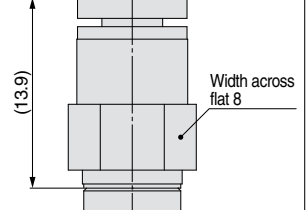

KJH04-M5 [Weight: 2.4 g]\*2

\*1 Refer to "ZP3-T▲▲UM□☆■■■-B5" for dimensions.

\*2 When calculating the weight, add the weight of the fitting to "ZP3-T▲▲UM□☆■■■-B5".

Pad diameter  $\phi 4$  to  $\phi 8$

Pad type Flat with groove

Stroke 15, 20 mm

Dimensions/With Buffer: Vacuum Inlet **Vertical**

ZP3-T04UM  $\square$  JB  $\blacksquare$  B5

ZP3-T04UM  $\square$  K  $\blacksquare$  B5

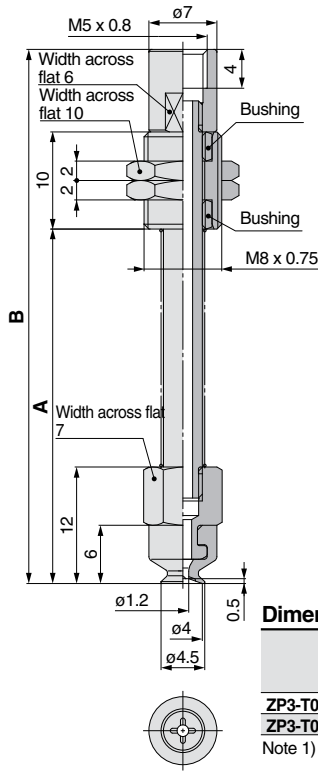

Dimensions (per stroke)

Model	A	B	Weight (g)	
			Non-rotating (J)	Rotating (K)
ZP3-T04UM $\square$ 15-B5	36.5	55	10.3	12.3
ZP3-T04UM $\square$ 20-B5	44	62.5	10.9	13.4

Note 1)  $\square$  in the table indicates the pad material "N, S, U, F, GN, GS."  
Note 2) The symbol "☆" indicates buffer type "JB" or "K".

ZP3-T06UM  $\square$  JB  $\blacksquare$  B5

ZP3-T06UM  $\square$  K  $\blacksquare$  B5

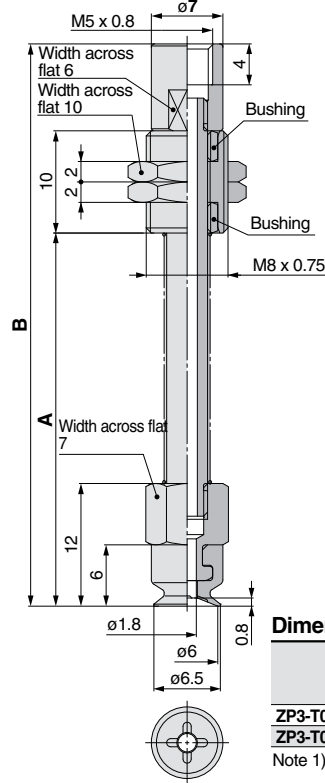

Dimensions (per stroke)

Model	A	B	Weight (g)	
			Non-rotating (J)	Rotating (K)
ZP3-T06UM $\square$ 15-B5	36.5	55	10.3	12.3
ZP3-T06UM $\square$ 20-B5	44	62.5	10.9	13.4

Note 1)  $\square$  in the table indicates the pad material "N, S, U, F, GN, GS."  
Note 2) The symbol "☆" indicates buffer type "JB" or "K".

ZP3-T08UM  $\square$  JB  $\blacksquare$  B5

ZP3-T08UM  $\square$  K  $\blacksquare$  B5

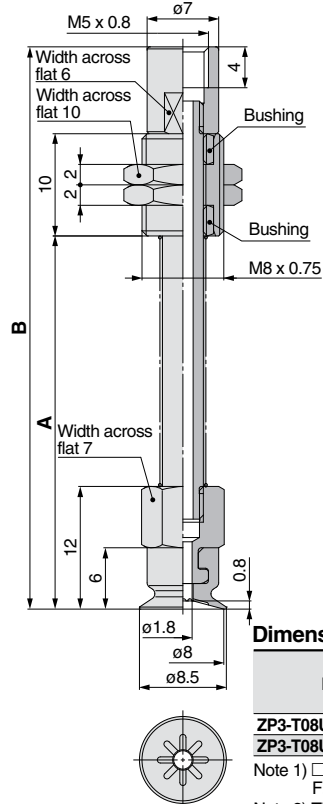

Dimensions (per stroke)

Model	A	B	Weight (g)	
			Non-rotating (J)	Rotating (K)
ZP3-T08UM $\square$ 15-B5	36.5	55	10.3	12.3
ZP3-T08UM $\square$ 20-B5	44	62.5	10.9	13.4

Note 1)  $\square$  in the table indicates the pad material "N, S, U, F, GN, GS."  
Note 2) The symbol "☆" indicates buffer type "JB" or "K".

Vacuum Inlet Dimensions

Barb fitting

ZP3-T04UM  $\square$  ☆  $\blacksquare$  U2  
ZP3-T06UM  $\square$  ☆  $\blacksquare$  U2  
ZP3-T08UM  $\square$  ☆  $\blacksquare$  U2

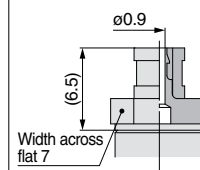

M-5AU-2 [Weight: 1.5 g]<sup>\*2</sup>

ZP3-T04UM  $\square$  ☆  $\blacksquare$  U4  
ZP3-T06UM  $\square$  ☆  $\blacksquare$  U4  
ZP3-T08UM  $\square$  ☆  $\blacksquare$  U4

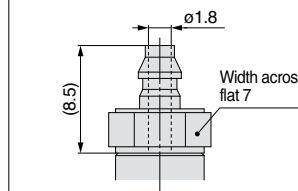

M-5AU-4-X83 [Weight: 1.6 g]<sup>\*2</sup>

One-touch fitting

ZP3-T04UM  $\square$  ☆  $\blacksquare$  O2  
ZP3-T06UM  $\square$  ☆  $\blacksquare$  O2  
ZP3-T08UM  $\square$  ☆  $\blacksquare$  O2

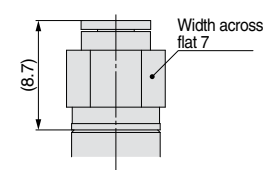

KJH02-M5 [Weight: 1.9 g]<sup>\*2</sup>

ZP3-T04UM  $\square$  ☆  $\blacksquare$  O4  
ZP3-T06UM  $\square$  ☆  $\blacksquare$  O4  
ZP3-T08UM  $\square$  ☆  $\blacksquare$  O4

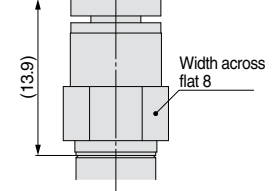

KJH04-M5 [Weight: 2.4 g]<sup>\*2</sup>

\*1 Refer to "ZP3-T▲▲UM  $\square$  ☆  $\blacksquare$  B5" for dimensions.

\*2 When calculating the weight, add the weight of the fitting to "ZP3-T▲▲UM  $\square$  ☆  $\blacksquare$  B5".

Pad Unit

Vertical

With Adapter:  
Vacuum Inlet

Vertical

With Buffer:  
Vacuum Inlet

Lateral

With Adapter:  
Vacuum Inlet

Lateral

With Buffer:  
Vacuum Inlet

Construction

Adapter Applicable  
Pad List

Buffer Applicable  
Pad List

Mounting Adapter  
Part No.

Buffer Assembly  
Part No.

Pad diameter  $\phi 10$  to  $\phi 16$

Pad type Flat with groove

Stroke 3, 6, 10 mm

## Dimensions/With Buffer: Vacuum Inlet

## Vertical

ZP3-T10UM□J■-B5

ZP3-T10UM□K■-B5

ZP3-T13UM□J■-B5

ZP3-T13UM□K■-B5

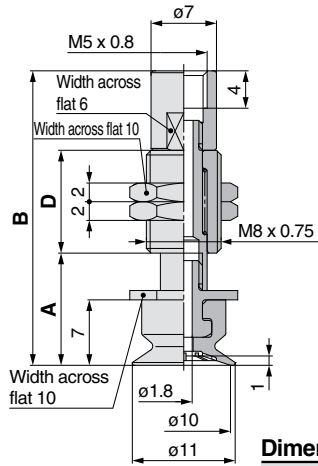

Dimensions (per stroke)

Model	A	B	D	Weight (g)	
				Non-rotating (J)	Rotating (K)
ZP3-T10UM□☆3-B5	12	31.5	11	8.4	8.3
ZP3-T10UM□☆6-B5	15	38	14.5	9.6	9.6
ZP3-T10UM□☆10-B5	19	48	20.5	11.7	11.7

Note 1) □ in the table indicates the pad material "N, S, U, F, GN, GS."

Note 2) The symbol "☆" indicates buffer type "J" or "K".

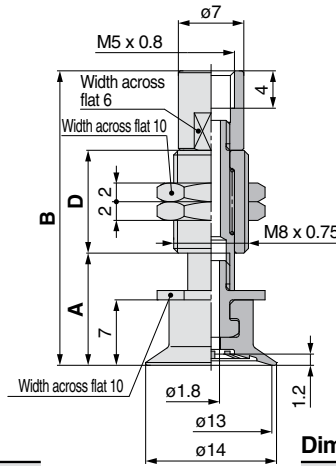

Dimensions (per stroke)

Model	A	B	D	Weight (g)	
				Non-rotating (J)	Rotating (K)
ZP3-T13UM□☆3-B5	12	31.5	11	8.5	8.4
ZP3-T13UM□☆6-B5	15	38	14.5	9.7	9.7
ZP3-T13UM□☆10-B5	19	48	20.5	11.8	11.8

Note 1) □ in the table indicates the pad material "N, S, U, F, GN, GS."

Note 2) The symbol "☆" indicates buffer type "J" or "K".

ZP3-T16UM□J■-B5

ZP3-T16UM□K■-B5

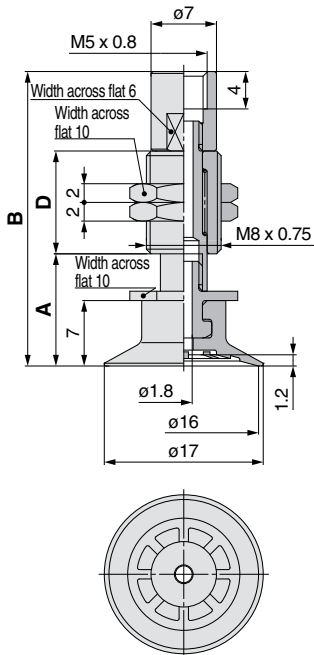

Dimensions (per stroke)

Model	A	B	D	Weight (g)	
				Non-rotating (J)	Rotating (K)
ZP3-T16UM□☆3-B5	12	31.5	11	8.6	8.5
ZP3-T16UM□☆6-B5	15	38	14.5	9.8	9.8
ZP3-T16UM□☆10-B5	19	48	20.5	11.9	11.9

Note 1) □ in the table indicates the pad material "N, S, U, F, GN, GS."

Note 2) The symbol "☆" indicates buffer type "J" or "K".

## Vacuum Inlet Dimensions

### Barb fitting

ZP3-T10UM□☆■-U2  
ZP3-T13UM□☆■-U2  
ZP3-T16UM□☆■-U2

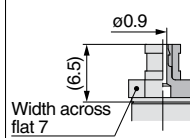

M-5AU-2 [Weight: 1.5 g]<sup>\*2</sup>

ZP3-T10UM□☆■-U4  
ZP3-T13UM□☆■-U4  
ZP3-T16UM□☆■-U4

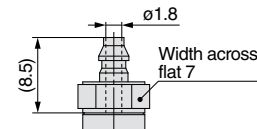

M-5AU-4-X83 [Weight: 1.6 g]<sup>\*2</sup>

ZP3-T10UM□☆■-U6  
ZP3-T13UM□☆■-U6  
ZP3-T16UM□☆■-U6

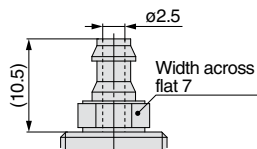

M-5AU-6-X83 [Weight: 1.8 g]<sup>\*2</sup>

### One-touch fitting

ZP3-T10UM□☆■-02  
ZP3-T13UM□☆■-02  
ZP3-T16UM□☆■-02

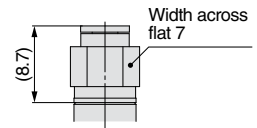

KJH02-M5 [Weight: 1.9 g]<sup>\*2</sup>

ZP3-T10UM□☆■-04  
ZP3-T13UM□☆■-04  
ZP3-T16UM□☆■-04

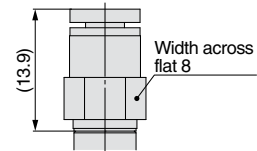

KJH04-M5 [Weight: 2.4 g]<sup>\*2</sup>

ZP3-T10UM□☆■-06  
ZP3-T13UM□☆■-06  
ZP3-T16UM□☆■-06

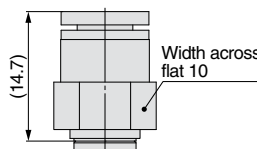

KJH06-M5 [Weight: 3.3 g]<sup>\*2</sup>

\*1 Refer to "ZP3-T▲▲UM□☆■-B5" for dimensions.

\*2 When calculating the weight, add the weight of the fitting to "ZP3-T▲▲UM□☆■-B5".

Pad diameter  $\varnothing 10$  to  $\varnothing 16$

Pad type Flat with groove

Stroke 15, 20 mm

Dimensions/With Buffer: Vacuum Inlet

**Vertical**

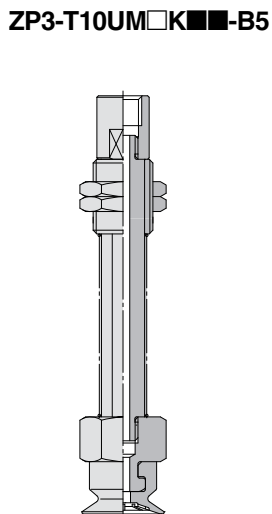
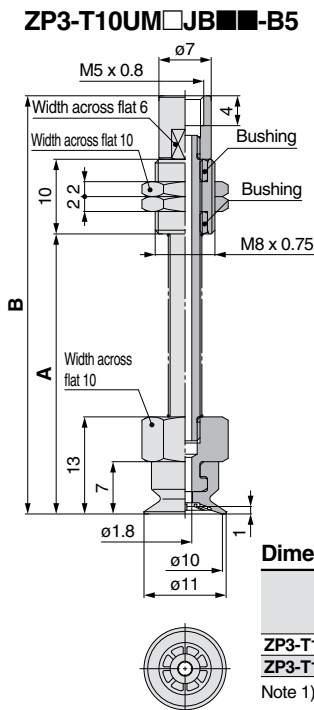

Dimensions (per stroke)

Model	A	B	Weight (g)	
			Non-rotating (J)	Rotating (K)
ZP3-T10UM $\square$ ☆ 15-B5	37.5	56	13.1	15.1
ZP3-T10UM $\square$ ☆ 20-B5	45	63.5	16.2	16.2

Note 1)  $\square$  in the table indicates the pad material "N, S, U, F, GN, GS."

Note 2) The symbol "☆" indicates buffer type "JB" or "K".

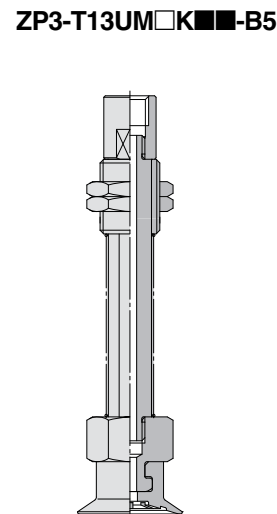
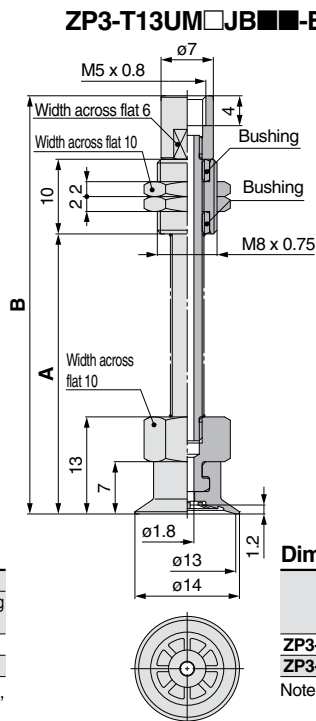

Dimensions (per stroke)

Model	A	B	Weight (g)	
			Non-rotating (J)	Rotating (K)
ZP3-T13UM $\square$ ☆ 15-B5	37.5	56	13.2	15.2
ZP3-T13UM $\square$ ☆ 20-B5	45	63.5	16.3	16.3

Note 1)  $\square$  in the table indicates the pad material "N, S, U, F, GN, GS."

Note 2) The symbol "☆" indicates buffer type "JB" or "K".

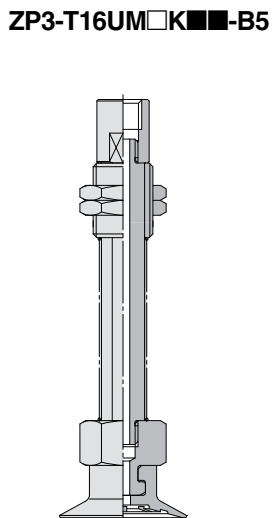
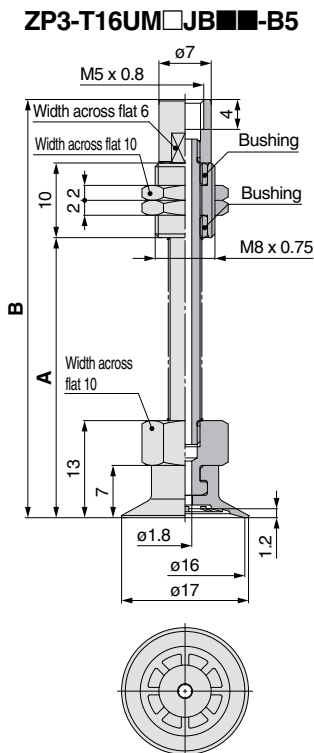

Dimensions (per stroke)

Model	A	B	Weight (g)	
			Non-rotating (J)	Rotating (K)
ZP3-T16UM $\square$ ☆ 15-B5	37.5	56	13.3	15.3
ZP3-T16UM $\square$ ☆ 20-B5	45	63.5	16.4	16.4

Note 1)  $\square$  in the table indicates the pad material "N, S, U, F, GN, GS."

Note 2) The symbol "☆" indicates buffer type "JB" or "K".

Vacuum Inlet Dimensions

Barb fitting

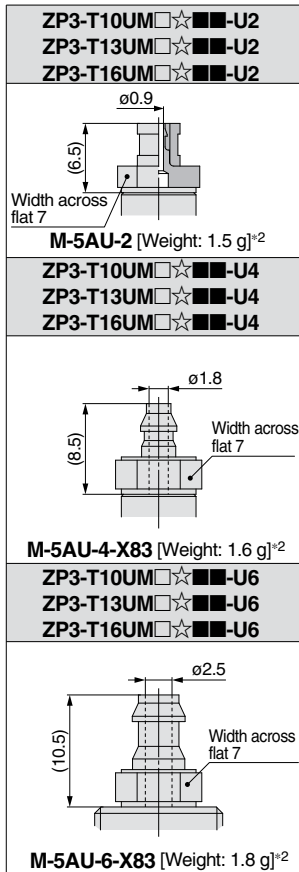

One-touch fitting

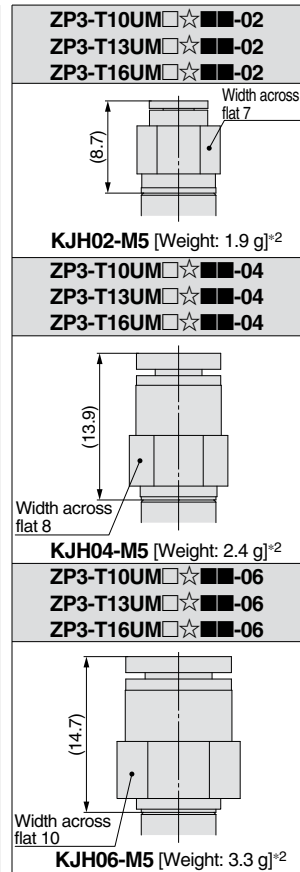

\*1 Refer to "ZP3-T▲▲UM  $\square$  ☆  $\blacksquare$  B5" for dimensions.

\*2 When calculating the weight, add the weight of the fitting to "ZP3-T▲▲UM  $\square$  ☆  $\blacksquare$  B5".

Pad Unit  
Vertical  
With Adapter: Vacuum Inlet  
Vertical  
With Buffer: Vacuum Inlet  
Lateral  
With Adapter: Vacuum Inlet  
Lateral  
With Buffer: Vacuum Inlet  
Construction  
Adapter Applicable Pad List  
Buffer Applicable Pad List  
Mounting Adapter Part No.  
Buffer Assembly Part No.



Pad diameter  $\varnothing 4$  to  $\varnothing 8$

Pad type **Bellows**

Stroke **15, 20 mm**

Dimensions/With Buffer: Vacuum Inlet **Vertical**

ZP3-T04B□JB■-B5

ZP3-T04B□K■-B5

ZP3-T06B□JB■-B5

ZP3-T06B□K■-B5

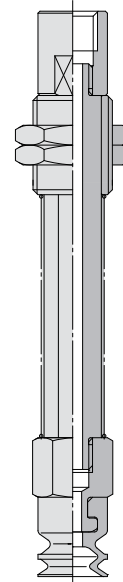
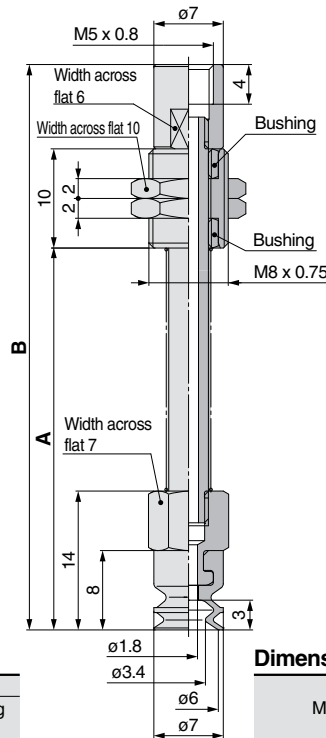
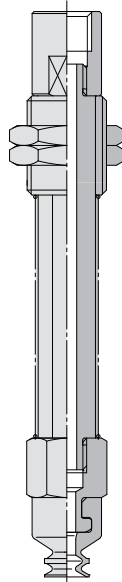
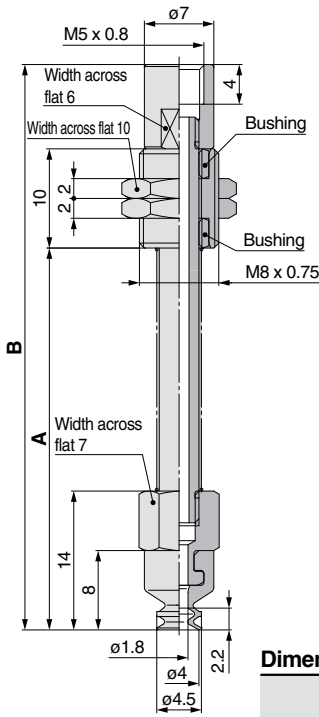

Dimensions (per stroke)

Model	A	B	Weight (g)	
			Non-rotating (J)	Rotating (K)
ZP3-T04B□☆15-B5	38.5	57	10.3	12.3
ZP3-T04B□☆20-B5	46	64.5	10.9	13.4

Note 1) □ in the table indicates the pad material "N, S, U, F, GN, GS."

Note 2) The symbol "☆" indicates buffer type "JB" or "K".

Dimensions (per stroke)

Model	A	B	Weight (g)	
			Non-rotating (J)	Rotating (K)
ZP3-T06B□☆15-B5	38.5	57	10.3	12.3
ZP3-T06B□☆20-B5	46	64.5	10.9	13.4

Note 1) □ in the table indicates the pad material "N, S, U, F, GN, GS."

Note 2) The symbol "☆" indicates buffer type "JB" or "K".

ZP3-T08B□JB■-B5

ZP3-T08B□K■-B5

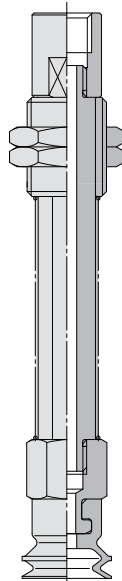
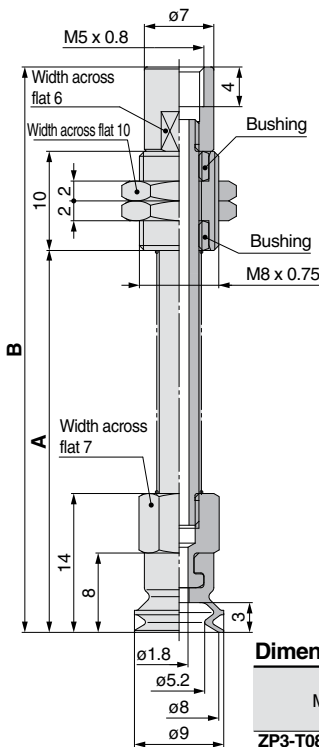

Dimensions (per stroke)

Model	A	B	Weight (g)	
			Non-rotating (J)	Rotating (K)
ZP3-T08B□☆15-B5	38.5	57	10.4	12.4
ZP3-T08B□☆20-B5	46	64.5	11.0	13.5

Note 1) □ in the table indicates the pad material "N, S, U, F, GN, GS."

Note 2) The symbol "☆" indicates buffer type "JB" or "K".

Vacuum Inlet Dimensions

Barb fitting	One-touch fitting
<p>ZP3-T04B□☆■-U2 ZP3-T06B□☆■-U2 ZP3-T08B□☆■-U2</p> <p>M-5AU-2 [Weight: 1.5 g]*2</p>	<p>ZP3-T04B□☆■-02 ZP3-T06B□☆■-02 ZP3-T08B□☆■-02</p> <p>KJH02-M5 [Weight: 1.9 g]*2</p>
<p>ZP3-T04B□☆■-U4 ZP3-T06B□☆■-U4 ZP3-T08B□☆■-U4</p> <p>M-5AU-4-X83 [Weight: 1.6 g]*2</p>	<p>ZP3-T04B□☆■-04 ZP3-T06B□☆■-04 ZP3-T08B□☆■-04</p> <p>KJH04-M5 [Weight: 2.4 g]*2</p>

\*1 Refer to "ZP3-T▲▲B□☆■-B5" for dimensions.

\*2 When calculating the weight, add the weight of the fitting to "ZP3-T▲▲B□☆■-B5".

Pad Unit  
Vertical  
With Adapter: Vacuum Inlet  
Vertical  
With Buffer: Vacuum Inlet  
Lateral  
With Adapter: Vacuum Inlet  
Lateral  
With Buffer: Vacuum Inlet  
Construction  
Adapter Applicable Pad List  
Buffer Applicable Pad List  
Mounting Adapter Part No.  
Buffer Assembly Part No.

Pad diameter  $\phi 10$  to  $\phi 16$

Pad type Bellows

Stroke 3, 6, 10 mm

## Dimensions/With Buffer: Vacuum Inlet **Vertical**

ZP3-T10B□J■-B5

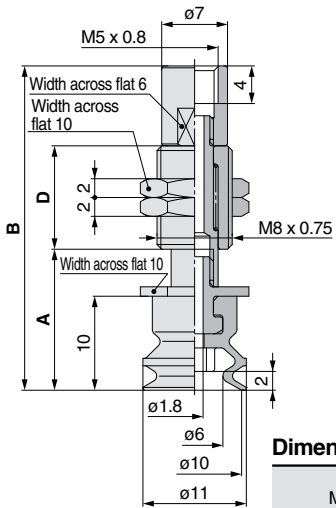

ZP3-T10B□K■-B5

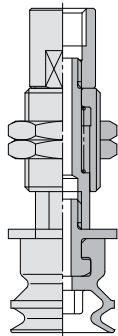

ZP3-T13B□J■-B5

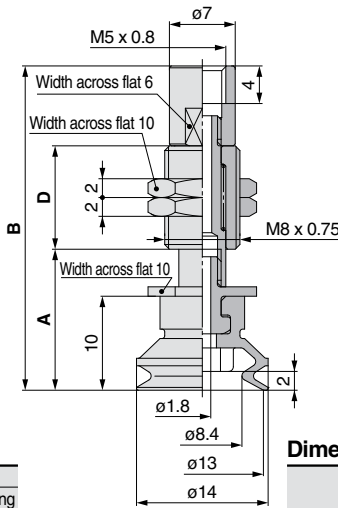

ZP3-T13B□K■-B5

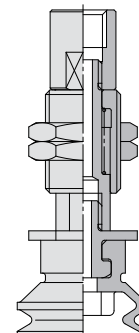

Dimensions (per stroke)

Model	A	B	D	Weight (g)	
				Non-rotating (J)	Rotating (K)
ZP3-T10B□☆3-B5	15	34.5	11	8.6	8.5
ZP3-T10B□☆6-B5	18	41	14.5	9.7	9.7
ZP3-T10B□☆10-B5	22	51	20.5	11.7	11.7

Note 1) □ in the table indicates the pad material "N, S, U, F, GN, GS."

Note 2) The symbol "☆" indicates buffer type "J" or "K".

Dimensions (per stroke)

Model	A	B	D	Weight (g)	
				Non-rotating (J)	Rotating (K)
ZP3-T13B□☆3-B5	15	34.5	11	8.7	8.6
ZP3-T13B□☆6-B5	18	41	14.5	9.8	9.8
ZP3-T13B□☆10-B5	22	51	20.5	11.8	11.8

Note 1) □ in the table indicates the pad material "N, S, U, F, GN, GS."

Note 2) The symbol "☆" indicates buffer type "J" or "K".

ZP3-T16B□J■-B5

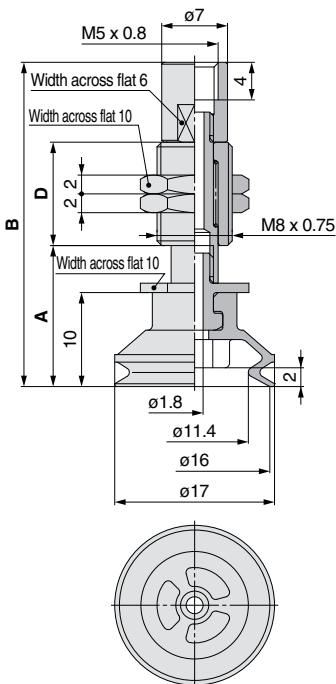

ZP3-T16B□K■-B5

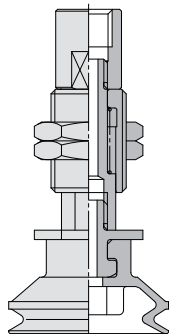

Dimensions (per stroke)

Model	A	B	D	Weight (g)	
				Non-rotating (J)	Rotating (K)
ZP3-T16B□☆3-B5	15	34.5	11	8.8	8.7
ZP3-T16B□☆6-B5	18	41	14.5	9.9	9.9
ZP3-T16B□☆10-B5	22	51	20.5	11.9	11.9

Note 1) □ in the table indicates the pad material "N, S, U, F, GN, GS."

Note 2) The symbol "☆" indicates buffer type "J" or "K".

## Vacuum Inlet Dimensions

Barb fitting

ZP3-T10B□☆■-U2  
ZP3-T13B□☆■-U2  
ZP3-T16B□☆■-U2

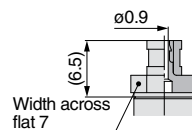

M-5AU-2 [Weight: 1.5 g]<sup>\*2</sup>

ZP3-T10B□☆■-U4  
ZP3-T13B□☆■-U4  
ZP3-T16B□☆■-U4

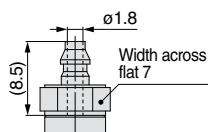

M-5AU-4-X83 [Weight: 1.6 g]<sup>\*2</sup>

ZP3-T10B□☆■-U6  
ZP3-T13B□☆■-U6  
ZP3-T16B□☆■-U6

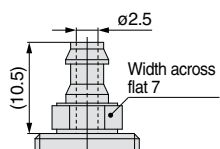

M-5AU-6-X83 [Weight: 1.8 g]<sup>\*2</sup>

One-touch fitting

ZP3-T10B□☆■-02  
ZP3-T13B□☆■-02  
ZP3-T16B□☆■-02

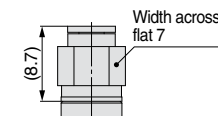

KJH02-M5 [Weight: 1.9 g]<sup>\*2</sup>

ZP3-T10B□☆■-04  
ZP3-T13B□☆■-04  
ZP3-T16B□☆■-04

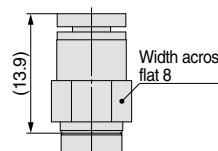

KJH04-M5 [Weight: 2.4 g]<sup>\*2</sup>

ZP3-T10B□☆■-06  
ZP3-T13B□☆■-06  
ZP3-T16B□☆■-06

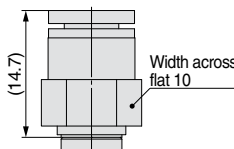

KJH06-M5 [Weight: 3.3 g]<sup>\*2</sup>

\*1 Refer to "ZP3-T▲▲B□☆■-B5" for dimensions.

\*2 When calculating the weight, add the weight of the fitting to "ZP3-T▲▲B□☆■-B5".



Pad diameter  $\phi 10$  to  $\phi 16$

Pad type **Bellows**

Stroke **15, 20 mm**

Dimensions/With Buffer: Vacuum Inlet **Vertical**

ZP3-T10B□JB■-B5

ZP3-T10B□K■-B5

ZP3-T13B□JB■-B5

ZP3-T13B□K■-B5

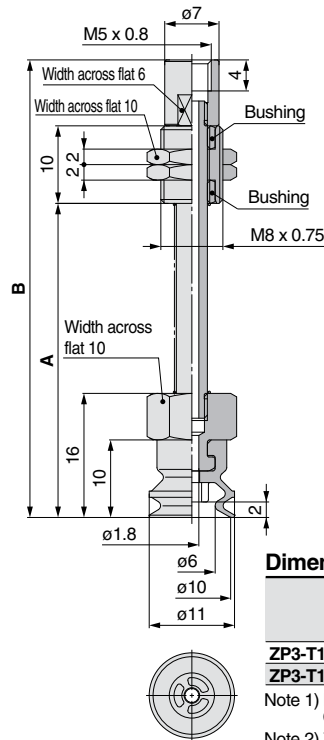

Dimensions (per stroke)

Model	A	B	Weight (g)	
			Non-rotating (J)	Rotating (K)
ZP3-T10B□☆15-B5	40.5	59	13.3	15.3
ZP3-T10B□☆20-B5	48	66.5	16.4	16.4

Note 1) □ in the table indicates the pad material "N, S, U, F, GN, GS."

Note 2) The symbol "☆" indicates buffer type "JB" or "K".

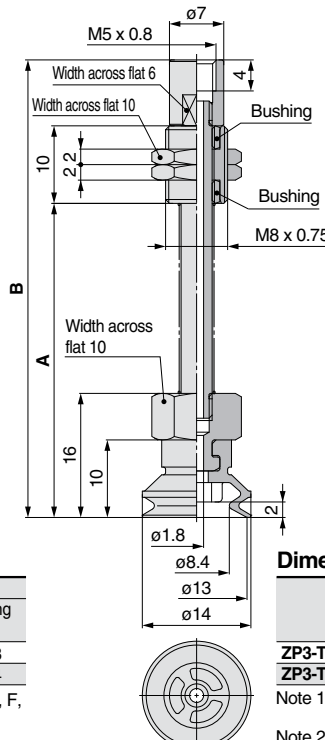

Dimensions (per stroke)

Model	A	B	Weight (g)	
			Non-rotating (J)	Rotating (K)
ZP3-T13B□☆15-B5	40.5	59	13.5	15.5
ZP3-T13B□☆20-B5	48	66.5	16.6	16.6

Note 1) □ in the table indicates the pad material "N, S, U, F, GN, GS."

Note 2) The symbol "☆" indicates buffer type "JB" or "K".

ZP3-T16B□JB■-B5

ZP3-T16B□K■-B5

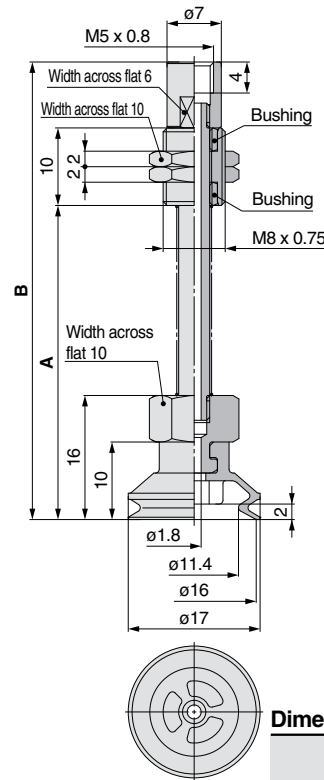

Dimensions (per stroke)

Model	A	B	Weight (g)	
			Non-rotating (J)	Rotating (K)
ZP3-T16B□☆15-B5	40.5	59	13.6	15.6
ZP3-T16B□☆20-B5	48	66.5	16.7	16.7

Note 1) □ in the table indicates the pad material "N, S, U, F, GN, GS."

Note 2) The symbol "☆" indicates buffer type "JB" or "K".

Vacuum Inlet Dimensions

Barb fitting

ZP3-T10B□☆■-U2  
ZP3-T13B□☆■-U2  
ZP3-T16B□☆■-U2

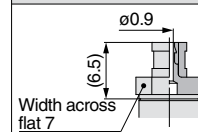

M-5AU-2 [Weight: 1.5 g]<sup>\*2</sup>

ZP3-T10B□☆■-U4  
ZP3-T13B□☆■-U4  
ZP3-T16B□☆■-U4

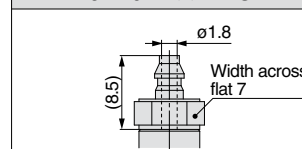

M-5AU-4-X83 [Weight: 1.6 g]<sup>\*2</sup>

ZP3-T10B□☆■-U6  
ZP3-T13B□☆■-U6  
ZP3-T16B□☆■-U6

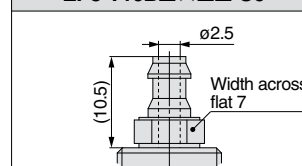

M-5AU-6-X83 [Weight: 1.8 g]<sup>\*2</sup>

One-touch fitting

ZP3-T10B□☆■-02  
ZP3-T13B□☆■-02  
ZP3-T16B□☆■-02

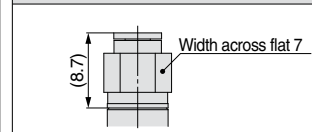

KJH02-M5 [Weight: 1.9 g]<sup>\*2</sup>

ZP3-T10B□☆■-04  
ZP3-T13B□☆■-04  
ZP3-T16B□☆■-04

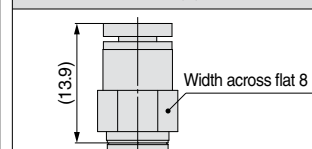

KJH04-M5 [Weight: 2.4 g]<sup>\*2</sup>

ZP3-T10B□☆■-06  
ZP3-T13B□☆■-06  
ZP3-T16B□☆■-06

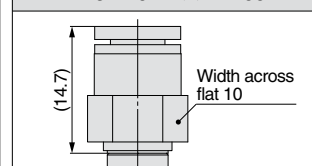

KJH06-M5 [Weight: 3.3 g]<sup>\*2</sup>

\*1 Refer to "ZP3-T▲▲B□☆■-B5" for dimensions.

\*2 When calculating the weight, add the weight of the fitting to "ZP3-T▲▲B□☆■-B5".



## How to Order

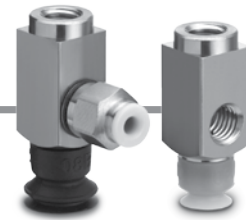

Lateral vacuum inlet/  
With adapter

ZP3 – Y 015 U N – B3 – B3

• Vacuum inlet direction

Symbol	Direction
Y	Lateral

• Pad diameter

Symbol	Pad diameter
015	ø1.5
02	ø2
035	ø3.5
04	ø4
06	ø6
08	ø8
10	ø10
13	ø13
16	ø16

• Vacuum inlet (◇)

	Symbol	Connection	ø1.5 to ø3.5	ø4 to ø8	ø10 to ø16
Female thread	B3	M3 x 0.5	●	—	—
	B5	M5 x 0.8	—	●	●
Barb fitting	U2	ø2 tubing *1	—	●	●
	U4	ø4 tubing *2	●	●	●
	U6	ø6 tubing *2	—	—	●
One-touch fitting	02	ø2	—	●	●
	04	ø4	●	●	●
	06	ø6	—	—	●

\*1 Polyurethane tube piping

\*2 Soft nylon/Polyurethane tube piping

• Mounting thread size

	Symbol	Thread size	ø1.5 to ø3.5	ø4 to ø16
Female thread	B3	M3 x 0.5	●	—
	B5	M5 x 0.8	—	●

• Pad material (□)

Symbol	Material
N	NBR
S	Silicone rubber
U	Urethane rubber
F	FKM
GN	Conductive NBR
GS	Conductive silicone rubber

• Pad type – Pad diameter

Pad type	Pad diameter (Symbol)								
	015	02	035	04	06	08	10	13	16
U (Flat)	●	●	●	—	—	—	—	—	—
UM (Flat with groove)	—	—	—	●	●	●	●	●	●
B (Bellows)	—	—	—	●	●	●	●	●	●

## Specifications

### Pad diameter: ø1.5 to ø3.5

Model	Pad unit part no.	Adapter part no.
ZP3-Y(015/02/035)U□-B3-◇	ZP3-(015/02/035)U□	ZP3A-Y1-B3

Note 1) ● in the table indicates the pad material.

Note 2) ◆ in the table indicates the vacuum inlet.

Note 3) Fitting is ordered separately.

Suffix of how to order (◆) U2: M-3AU-2, U4: M-3AU-4-X83  
02: KJH02-M3, 04: KJH04-M3-X83

### Pad diameter: ø4 to ø8

Model	Pad unit part no.	Adapter part no.
ZP3-Y(04/06/08)UM□-B5-◇	ZP3-(04/06/08)UM□	ZP3A-Y2-B5
ZP3-Y(04/06/08)B□-B5-◇	ZP3-(04/06/08)B□	

Note 1) □ in the table indicates the pad material.

Note 2) ◇ in the table indicates the vacuum inlet.

Note 3) Fitting is ordered separately.

Suffix of how to order (◇) U2: M-5AU-2, U4: M-5AU-4-X83  
02: KJH02-M5, 04: KJH04-M5

### Pad diameter: ø10 to ø16

Model	Pad unit part no.	Adapter part no.
ZP3-Y(10/13/16)UM□-B5-◇	ZP3-(10/13/16)UM◆	ZP3A-Y3-B5
ZP3-Y(10/13/16)B□-B5-◇	ZP3-(10/13/16)B◆	

Note 1) ● in the table indicates the pad material.

Note 2) ◆ in the table indicates the vacuum inlet.

Note 3) Fitting is ordered separately.

Suffix of how to order (◆) U2: M-5AU-2, U4: M-5AU-4-X83  
U6: M-5AU-6-X83, 02: KJH02-M5  
04: KJH04-M5, 06: KJH06-M5

Pad diameter  $\phi 1.5$  to  $\phi 3.5$

Pad type Flat

Dimensions/With Adapter: Vacuum Inlet **Lateral**

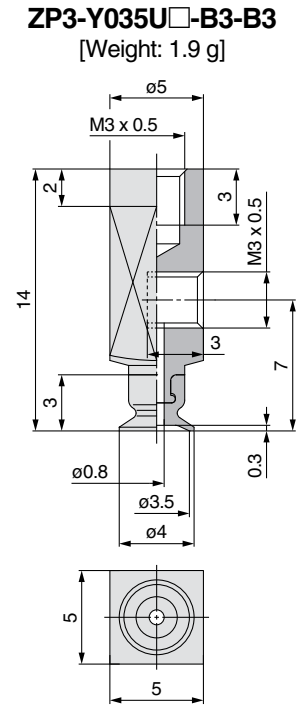
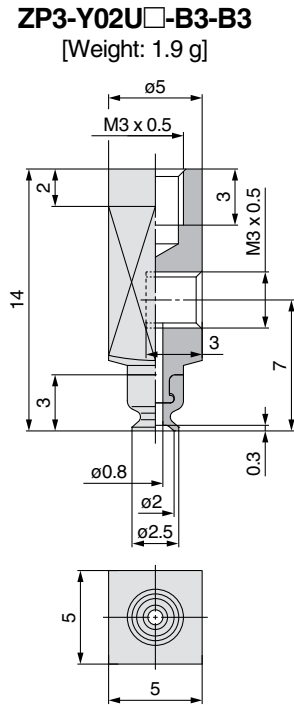
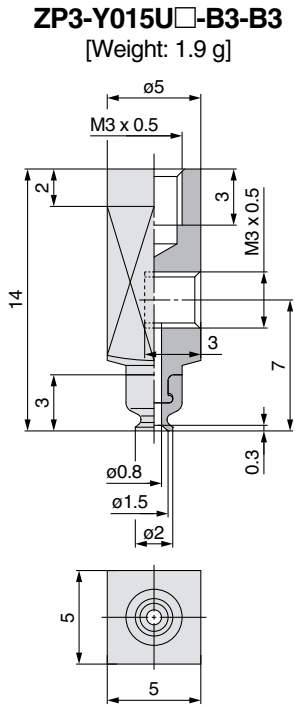

Vacuum Inlet Dimensions

Barb fitting	<p>ZP3-Y015U□-B3-U2 ZP3-Y02U□-B3-U2 ZP3-Y035U□-B3-U2</p> <p><b>M-3AU-2</b> [Weight: 0.7 g]<sup>*2</sup></p>	<p>ZP3-Y015U□-B3-U4 ZP3-Y02U□-B3-U4 ZP3-Y035U□-B3-U4</p> <p><b>M-3AU-4-X83</b> [Weight: 0.7 g]<sup>*2</sup></p>
	<p>ZP3-Y015U□-B3-02 ZP3-Y02U□-B3-02 ZP3-Y035U□-B3-02</p> <p><b>KJH02-M3</b> [Weight: 1.1 g]<sup>*2</sup></p>	<p>ZP3-Y015U□-B3-04 ZP3-Y02U□-B3-04 ZP3-Y035U□-B3-04</p> <p><b>KJH04-M3-X83</b> [Weight: 1.9 g]<sup>*2</sup></p>

\*1 Refer to "ZP3-Y▲▲▲U□-B3-B3" for dimensions. \*2 When calculating the weight, add the weight of the fitting to "ZP3-Y▲▲▲U□-B3-B3".

Pad Unit

Vertical  
With Adapter: Vacuum Inlet

Vertical  
With Buffer: Vacuum Inlet

Lateral  
With Adapter: Vacuum Inlet

Lateral  
With Buffer: Vacuum Inlet

Construction

Adapter Applicable  
Pad List

Buffer Applicable  
Pad List

Mounting Adapter  
Part No.

Buffer Assembly  
Part No.



Dimensions/With Adapter: Vacuum Inlet

**Lateral**

Pad diameter  $\phi 10$  to  $\phi 16$

Pad type Flat with groove

**ZP3-Y10UM□-B5-B5**  
[Weight: 7.7 g]

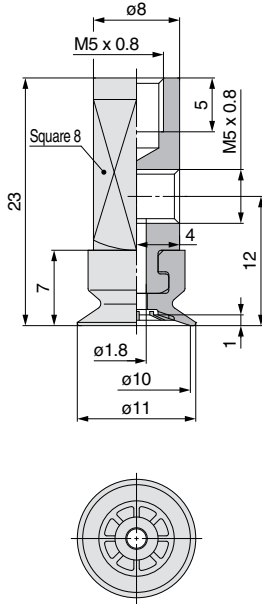

**ZP3-Y13UM□-B5-B5**  
[Weight: 7.8 g]

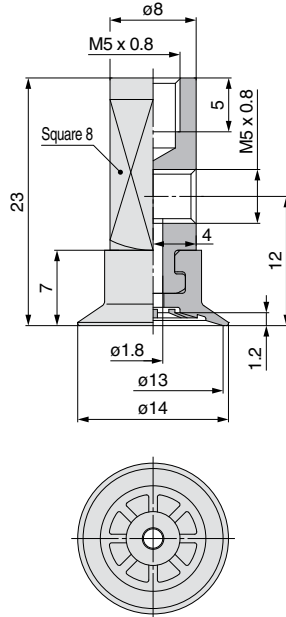

**ZP3-Y16UM□-B5-B5**  
[Weight: 7.9 g]

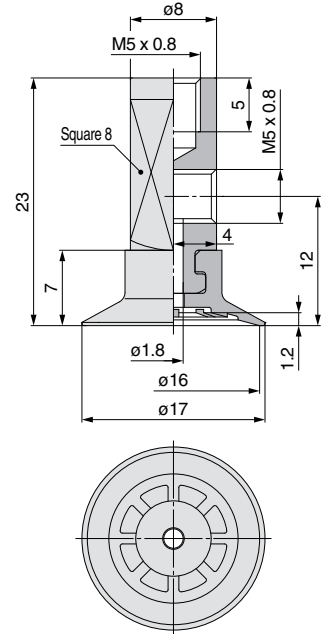

**Vacuum Inlet Dimensions**

Barb fitting	<p><b>ZP3-Y10UM□-B5-U2</b> <b>ZP3-Y13UM□-B5-U2</b> <b>ZP3-Y16UM□-B5-U2</b></p> <p><b>M-5AU-2</b> [Weight: 1.5 g]<sup>2</sup></p>	<p><b>ZP3-Y10UM□-B3-U4</b> <b>ZP3-Y13UM□-B3-U4</b> <b>ZP3-Y16UM□-B3-U4</b></p> <p><b>M-5AU-4-X83</b> [Weight: 1.6 g]<sup>2</sup></p>	<p><b>ZP3-Y10UM□-B5-U6</b> <b>ZP3-Y13UM□-B5-U6</b> <b>ZP3-Y16UM□-B5-U6</b></p> <p><b>M-5AU-6-X83</b> [Weight: 1.8 g]<sup>2</sup></p>	
	One-touch fitting	<p><b>ZP3-Y10UM□-B5-02</b> <b>ZP3-Y13UM□-B5-02</b> <b>ZP3-Y16UM□-B5-02</b></p> <p><b>KJH02-M5</b> [Weight: 1.9 g]<sup>2</sup></p>	<p><b>ZP3-Y10UM□-B3-04</b> <b>ZP3-Y13UM□-B3-04</b> <b>ZP3-Y16UM□-B3-04</b></p> <p><b>KJH04-M5</b> [Weight: 2.4 g]<sup>2</sup></p>	<p><b>ZP3-Y10UM□-B5-06</b> <b>ZP3-Y13UM□-B5-06</b> <b>ZP3-Y16UM□-B5-06</b></p> <p><b>KJH06-M5</b> [Weight: 3.3 g]<sup>2</sup></p>

\*1 Refer to "ZP3-Y▲▲UM□-B5-B5" for dimensions.

\*2 When calculating the weight, add the weight of the fitting to "ZP3-Y▲▲UM□-B5-B5".

**Pad Unit**  
 With Adapter: Vacuum Inlet  
 With Buffer: Vacuum Inlet  
 With Adapter: Vacuum Inlet  
 With Buffer: Vacuum Inlet  
**Construction**  
**Adapter Applicable Pad List**  
**Buffer Applicable Pad List**  
**Mounting Adapter Part No.**  
**Buffer Assembly Part No.**

Pad diameter  $\phi 4$  to  $\phi 8$

Pad type Bellows

## Dimensions/With Adapter: Vacuum Inlet **Lateral**

**ZP3-Y04B□-B5-B5**  
[Weight: 7.0 g]

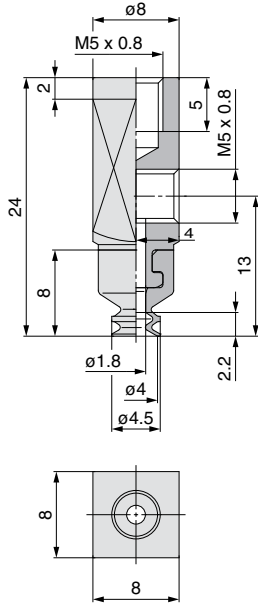

**ZP3-Y06B□-B5-B5**  
[Weight: 7.0 g]

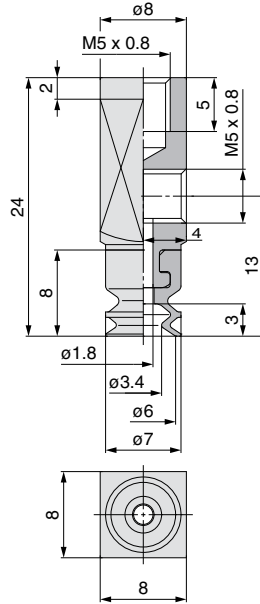

**ZP3-Y08B□-B5-B5**  
[Weight: 7.1 g]

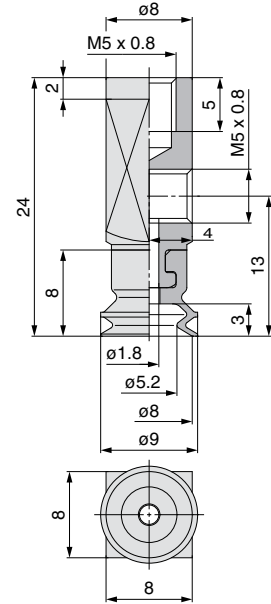

### Vacuum Inlet Dimensions

Barb fitting	<p>ZP3-Y04B□-B5-U2 ZP3-Y06B□-B5-U2 ZP3-Y08B□-B5-U2</p> <p><b>M-5AU-2</b> [Weight: 0.7 g]<sup>*2</sup></p>	<p>ZP3-Y04B□-B5-U4 ZP3-Y06B□-B5-U4 ZP3-Y08B□-B5-U4</p> <p><b>M-5AU-4-X83</b> [Weight: 0.7 g]<sup>*2</sup></p>
	One-touch fitting	<p>ZP3-Y04B□-B5-02 ZP3-Y06B□-B5-02 ZP3-Y08B□-B5-02</p> <p><b>KJH02-M5</b> [Weight: 1.1 g]<sup>*2</sup></p>

\*1 Refer to "ZP3-Y▲▲B□-B5-B5" for dimensions.

\*2 When calculating the weight, add the weight of the fitting to "ZP3-Y▲▲B□-B5-B5".

Pad diameter  $\phi 10$  to  $\phi 16$

Pad type **Bellows**

Dimensions/With Adapter: Vacuum Inlet **Lateral**

**ZP3-Y10B□-B5-B5**  
[Weight: 7.9 g]

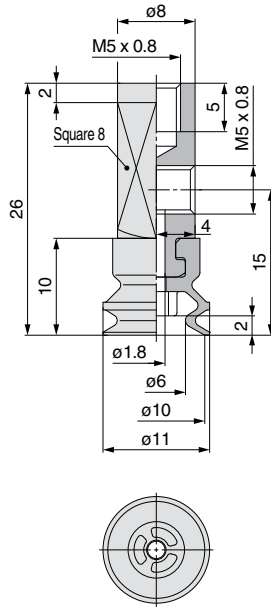

**ZP3-Y13B□-B5-B5**  
[Weight: 8.1 g]

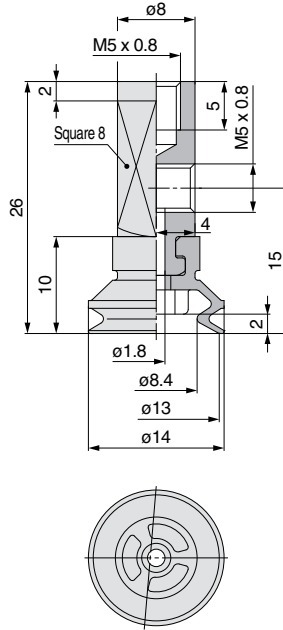

**ZP3-Y16B□-B5-B5**  
[Weight: 8.2 g]

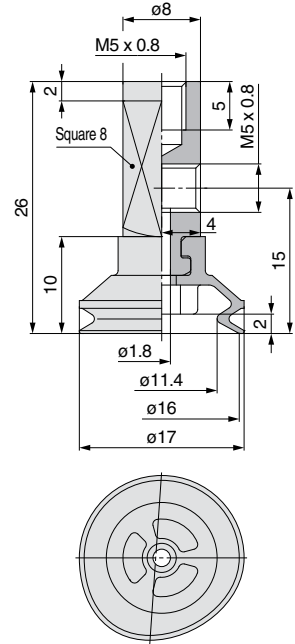

**Vacuum Inlet Dimensions**

	ZP3-Y10B□-B5-U2 ZP3-Y13B□-B5-U2 ZP3-Y16B□-B5-U2	ZP3-Y10B□-B5-U4 ZP3-Y13B□-B5-U4 ZP3-Y16B□-B5-U4	ZP3-Y10B□-B5-U6 ZP3-Y13B□-B5-U6 ZP3-Y16B□-B5-U6
<b>Barb fitting</b>			
	<b>M-5AU-2</b> [Weight: 1.5 g] <sup>*2</sup>	<b>M-5AU-4-X83</b> [Weight: 1.6 g] <sup>*2</sup>	<b>M-5AU-6-X83</b> [Weight: 1.8 g] <sup>*2</sup>
<b>One-touch fitting</b>	ZP3-Y10B□-B5-02 ZP3-Y13B□-B5-02 ZP3-Y16B□-B5-02	ZP3-Y10B□-B5-04 ZP3-Y13B□-B5-04 ZP3-Y16B□-B5-04	ZP3-Y10B□-B5-06 ZP3-Y13B□-B5-06 ZP3-Y16B□-B5-06
	<b>KJH02-M5</b> [Weight: 1.9 g] <sup>*2</sup>	<b>KJH04-M5</b> [Weight: 2.4 g] <sup>*2</sup>	<b>KJH06-M5</b> [Weight: 3.3 g] <sup>*2</sup>

\*1 Refer to "ZP3-Y▲▲B□-B5-B5" for dimensions.

\*2 When calculating the weight, add the weight of the fitting to "ZP3-Y▲▲B□-B5-B5".

Pad Unit

Vertical With Adapter: Vacuum Inlet

Vertical With Buffer: Vacuum Inlet

Lateral With Adapter: Vacuum Inlet

Lateral With Buffer: Vacuum Inlet

Construction

Adapter Applicable Pad List

Buffer Applicable Pad List

Mounting Adapter Part No.

Buffer Assembly Part No.

## How to Order

Lateral vacuum inlet/  
With buffer

### ZP3-Y 015 U N J 3 - B3

Vacuum inlet direction ●

Symbol	Direction
Y	Lateral

Pad diameter ●

Symbol	Pad diameter
015	ø1.5
02	ø2
035	ø3.5
04	ø4
06	ø6
08	ø8
10	ø10
13	ø13
16	ø16

Pad type – Pad diameter ●

Pad diameter (Symbol)	015	02	035	04	06
U (Flat)	●	●	●	—	—
UM (Flat with groove)	—	—	—	●	●
B (Bellows)	—	—	—	●	●

Pad diameter (Symbol)	08	10	13	16
U (Flat)	—	—	—	—
UM (Flat with groove)	●	●	●	●
B (Bellows)	●	●	●	●

Vacuum inlet (◇)

	Symbol	Connection	ø1.5 to ø3.5	ø4 to ø8	ø10 to ø16
Female thread	B3	M3 x 0.5	●	—	—
	B5	M5 x 0.8	—	●	●
Barb fitting	U2	ø2 tubing *1	●	●	●
	U4	ø4 tubing *2	●	●	●
	U6	ø6 tubing *2	—	—	●
One-touch fitting	02	ø2 tubing	●	●	●
	04	ø4 tubing	●	●	●
	06	ø6 tubing	—	—	●

\*1 Polyurethane tube piping

\*2 Soft nylon/Polyurethane tube piping

Stroke (■)—Buffer specifications

Stroke	ø1.5 to ø3.5		ø4 to ø16		
	J	K	J	JB	K
3	●	●	●	—	●
6	●	●	●	—	●
10	—	—	●	—	●
15	—	—	—	●	●
20	—	—	—	●	●

Buffer specifications (☆)

J	Non-rotating
JB	Non-rotating, With bushing
K	Rotating

Pad material (□)

Symbol	Material
N	NBR
S	Silicone rubber
U	Urethane rubber
F	FKM
GN	Conductive NBR
GS	Conductive silicone rubber

## Specifications

Pad diameter	Buffer specifications	Stroke (mm)	Tightening torque lbf-ft (N-m)	Mounting	Spring reactive force	
					At 0 stroke lbf (N)	At full stroke lbf (N)
ø1.5 to ø3.5	J	3, 6	1.1 to 1.33 (1.5 to 1.8) 1.48 to 1.84 (2.0 to 2.5)	M6 x 0.75 M8 x 0.75	0.045 (0.2)	0.09 (0.4) 0.11 (0.5)
	K					
ø4 to ø16	J	3, 6, 10	1.48 to 1.84 (2.0 to 2.5)	M8 x 0.75	0.045 (0.2)	0.11 (0.5)
	JB	15, 20				
	K	3, 6, 10, 15, 20				

## Replacement Part No.

Pad diameter: ø1.5 to ø3.5

Model	Pad unit part no.	Buffer assembly part no. (Note 3)
ZP3-Y(015/02/035)U□(J/K)3-◇	ZP3-(015/02/035)U●	ZP3B-Y1(J/K)3-B3
ZP3-Y(015/02/035)U□(J/K)6-◇		ZP3B-Y1(J/K)6-B3

Note 1) □ in the table indicates the pad material.

Note 2) ◇ in the table indicates the vacuum inlet.

Note 3) Fitting is ordered separately.

Suffix of how to order (◇) U2: M-3AU-2, U4: M-3AU-4-X83  
02: KJH02-M3, 04: KJH04-M3-X83

Pad diameter: ø4 to ø8

Model	Pad unit part no.	Buffer assembly part no. (Note 3)
ZP3-Y(04/06/08)UM□(J/K)3-◇	ZP3-(04/06/08)UM□	ZP3B-Y2A(J/K)3-B5
ZP3-Y(04/06/08)B□(J/K)3-◇	ZP3-(04/06/08)B□	
ZP3-Y(04/06/08)UM□(J/K)6-◇	ZP3-(04/06/08)UM□	ZP3B-Y2A(J/K)6-B5
ZP3-Y(04/06/08)B□(J/K)6-◇	ZP3-(04/06/08)B□	
ZP3-Y(04/06/08)UM□(J/K)10-◇	ZP3-(04/06/08)UM□	ZP3B-Y2A(J/K)10-B5
ZP3-Y(04/06/08)B□(J/K)10-◇	ZP3-(04/06/08)B□	
ZP3-Y(04/06/08)UM□(JB/K)15-◇	ZP3-(04/06/08)UM□	ZP3B-Y2A(JB/K)15-B5
ZP3-Y(04/06/08)B□(JB/K)15-◇	ZP3-(04/06/08)B□	
ZP3-Y(04/06/08)UM□(JB/K)20-◇	ZP3-(04/06/08)UM□	ZP3B-Y2A(JB/K)20-B5
ZP3-Y(04/06/08)B□(JB/K)20-◇	ZP3-(04/06/08)B□	

Note 1) □ in the table indicates the pad material.

Note 2) ◇ in the table indicates the vacuum inlet.

Note 3) Fitting is ordered separately.

Suffix of how to order (◇) U2: M-5AU-2, U4: M-5AU-4-X83  
02: KJH02-M5, 04: KJH04-M5

Pad diameter: ø10 to ø16

Model	Pad unit part no.	Buffer assembly part no. (Note 3)
ZP3-Y(10/13/16)UM□(J/K)3-◇	ZP3-(10/13/16)UM□	ZP3B-Y2B(J/K)3-B5
ZP3-Y(10/13/16)B□(J/K)3-◇	ZP3-(10/13/16)B□	
ZP3-Y(10/13/16)UM□(J/K)6-◇	ZP3-(10/13/16)UM□	ZP3B-Y2B(J/K)6-B5
ZP3-Y(10/13/16)B□(J/K)6-◇	ZP3-(10/13/16)B□	
ZP3-Y(10/13/16)UM□(J/K)10-◇	ZP3-(10/13/16)UM□	ZP3B-Y2B(J/K)10-B5
ZP3-Y(10/13/16)B□(J/K)10-◇	ZP3-(10/13/16)B□	
ZP3-Y(10/13/16)UM□(JB/K)15-◇	ZP3-(10/13/16)UM□	ZP3B-Y2B(JB/K)15-B5
ZP3-Y(10/13/16)B□(JB/K)15-◇	ZP3-(10/13/16)B□	
ZP3-Y(10/13/16)UM□(JB/K)20-◇	ZP3-(10/13/16)UM□	ZP3B-Y2B(JB/K)20-B5
ZP3-Y(10/13/16)B□(JB/K)20-◇	ZP3-(10/13/16)B□	

Note 1) □ in the table indicates the pad material.

Note 2) ◇ in the table indicates the vacuum inlet.

Note 3) Fitting is ordered separately.

Suffix of how to order (◇) U2: M-5AU-2, U4: M-5AU-4-X83  
U6: M-5AU-6-X83, 02: KJH02-M5  
04: KJH04-M5, 06: KJH06-M5

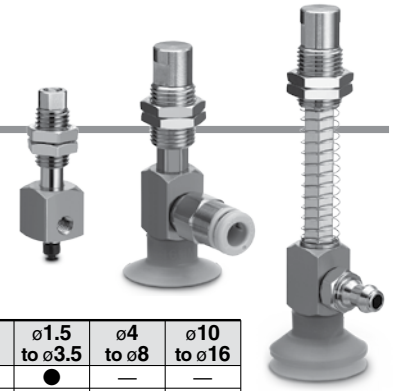



Pad diameter  $\varnothing 1.5$  to  $\varnothing 3.5$

Pad type **Flat**

Stroke **3, 6 mm**

Dimensions/With Buffer: Vacuum Inlet **Lateral**

Pad Unit

Vertical

With Adapter: Vacuum Inlet

Vertical  
With Buffer: Vacuum Inlet

Lateral  
With Adapter: Vacuum Inlet

Lateral  
With Buffer: Vacuum Inlet

Lateral  
With Buffer: Vacuum Inlet

Construction

Adapter Applicable  
Pad List

Buffer Applicable  
Pad List

Mounting Adapter  
Part No.

Buffer Assembly  
Part No.

ZP3-Y015U□J■-B3

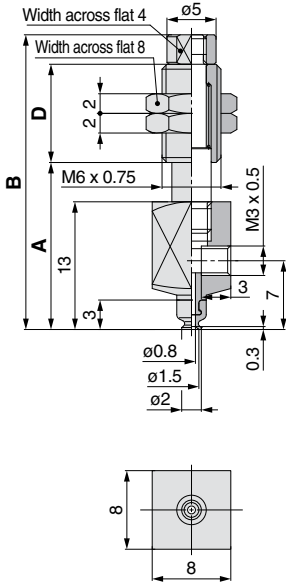

ZP3-Y015U□K■-B3

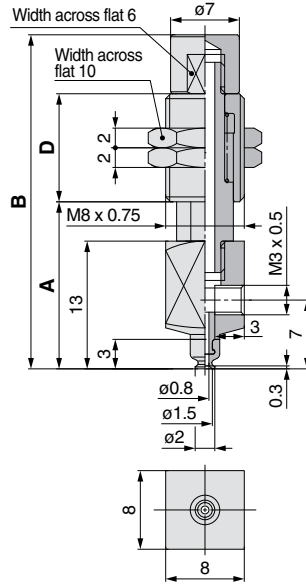

ZP3-Y02U□J■-B3

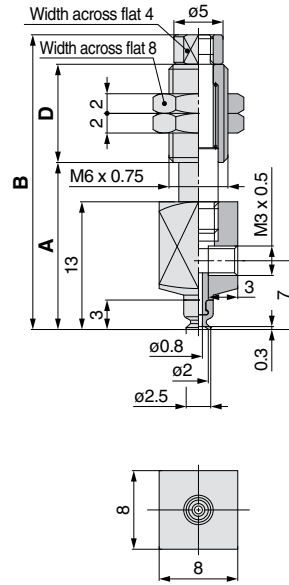

ZP3-Y02U□K■-B3

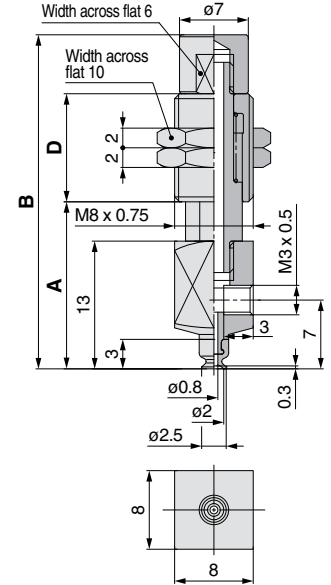

Dimensions (per stroke)

Model	A	B	D	Weight (g)
ZP3-Y015U□J3-B3	17	30	10	7.7
ZP3-Y015U□J6-B3	20	37	14	8.6

Note) □ in the table indicates the pad material "N, S, U, F, GN, GS."

Dimensions (per stroke)

Model	A	B	D	Weight (g)
ZP3-Y015U□K3-B3	17	34	11	11.0
ZP3-Y015U□K6-B3	20	40.5	14.5	12.2

Note) □ in the table indicates the pad material "N, S, U, F, GN, GS."

Dimensions (per stroke)

Model	A	B	D	Weight (g)
ZP3-Y02U□J3-B3	17	30	10	7.7
ZP3-Y02U□J6-B3	20	37	14	8.6

Note) □ in the table indicates the pad material "N, S, U, F, GN, GS."

Dimensions (per stroke)

Model	A	B	D	Weight (g)
ZP3-Y02U□K3-B3	17	34	11	11.0
ZP3-Y02U□K6-B3	20	40.5	14.5	12.2

Note) □ in the table indicates the pad material "N, S, U, F, GN, GS."

ZP3-Y035U□J■-B3

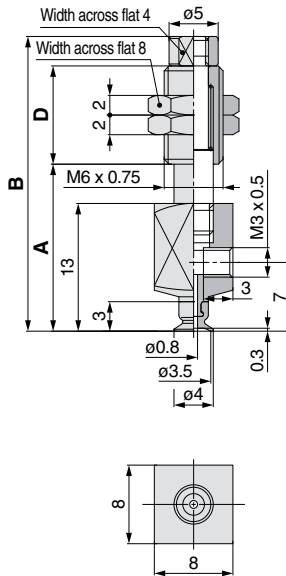

ZP3-Y035U□K■-B3

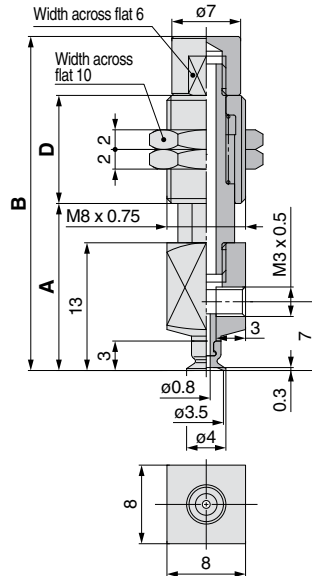

Dimensions (per stroke)

Model	A	B	D	Weight (g)
ZP3-Y035U□J3-B3	17	30	10	7.7
ZP3-Y035U□J6-B3	20	37	14	8.6

Note) □ in the table indicates the pad material "N, S, U, F, GN, GS."

Dimensions (per stroke)

Model	A	B	D	Weight (g)
ZP3-Y035U□K3-B3	17	34	11	11.0
ZP3-Y035U□K6-B3	20	40.5	14.5	12.2

Note) □ in the table indicates the pad material "N, S, U, F, GN, GS."

Vacuum Inlet Dimensions

Barb fitting

ZP3-Y015U□J■-U2  
ZP3-Y02U□J■-U2  
ZP3-Y035U□J■-U2

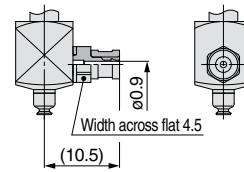

M-3AU-2 [Weight: 0.7 g]<sup>\*2</sup>

ZP3-Y015U□J■-U4  
ZP3-Y02U□J■-U4  
ZP3-Y035U□J■-U4

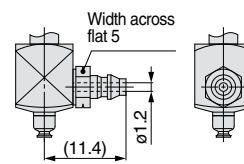

M-3AU-4-X83 [Weight: 0.7 g]<sup>\*2</sup>

One-touch fitting

ZP3-Y015U□K■-02  
ZP3-Y02U□K■-02  
ZP3-Y035U□K■-02

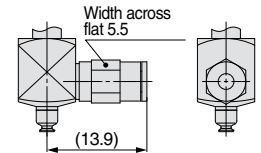

KJH02-M3 [Weight: 1.1 g]<sup>\*2</sup>

ZP3-Y015U□J■-04  
ZP3-Y02U□J■-04  
ZP3-Y035U□J■-04

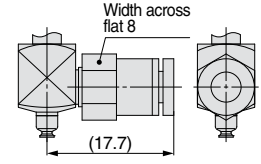

KJH04-M3-X83 [Weight: 1.9 g]<sup>\*2</sup>

\*1 Refer to "ZP3-Y▲▲▲U□☆■-B3" for dimensions.

\*2 When calculating the weight, add the weight of the fitting to "ZP3-Y▲▲▲U□☆■-B3".



Pad diameter  $\phi 4$  to  $\phi 8$

Pad type Flat with groove

Stroke 3, 6, 10 mm

## Dimensions/With Buffer: Vacuum Inlet **Lateral**

ZP3-Y04UM□J■-B5

ZP3-Y04UM□K■-B5

ZP3-Y06UM□J■-B5

ZP3-Y06UM□K■-B5

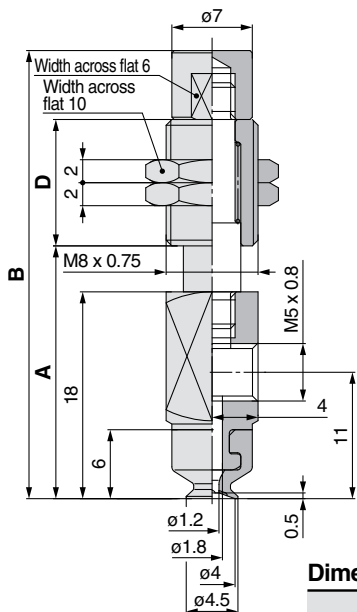

Dimensions (per stroke)

Model	A	B	D	Weight (g)	
				Non-rotating (J)	Rotating (K)
ZP3-Y04UM□☆3-B5	22.5	40	11	12.8	12.2
ZP3-Y04UM□☆6-B5	25	46	14.5	14.2	13.4
ZP3-Y04UM□☆10-B5	29	56	20.5	16.6	15.4

Note 1) □ in the table indicates the pad material "N, S, U, F, GN, GS."

Note 2) The symbol "☆" indicates buffer type "J" or "K".

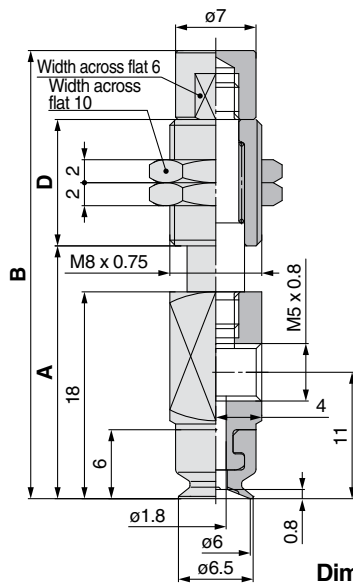

Dimensions (per stroke)

Model	A	B	D	Weight (g)	
				Non-rotating (J)	Rotating (K)
ZP3-Y06UM□☆3-B5	22.5	40	11	12.8	12.2
ZP3-Y06UM□☆6-B5	25	46	14.5	14.2	13.4
ZP3-Y06UM□☆10-B5	29	56	20.5	16.6	15.4

Note 1) □ in the table indicates the pad material "N, S, U, F, GN, GS."

Note 2) The symbol "☆" indicates buffer type "J" or "K".

ZP3-Y08UM□J■-B5

ZP3-Y08UM□K■-B5

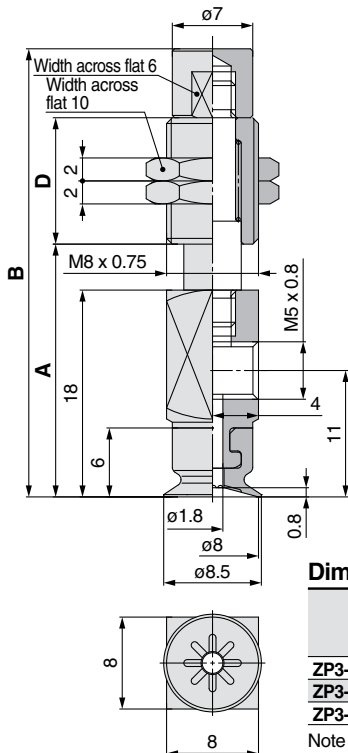

Dimensions (per stroke)

Model	A	B	D	Weight (g)	
				Non-rotating (J)	Rotating (K)
ZP3-Y08UM□☆3-B5	22.5	40	11	12.8	12.2
ZP3-Y08UM□☆6-B5	25	46	14.5	14.2	13.4
ZP3-Y08UM□☆10-B5	29	56	20.5	16.6	15.4

Note 1) □ in the table indicates the pad material "N, S, U, F, GN, GS."

Note 2) The symbol "☆" indicates buffer type "J" or "K".

## Vacuum Inlet Dimensions

### Barb fitting

ZP3-Y04UM□☆■-U2  
ZP3-Y06UM□☆■-U2  
ZP3-Y08UM□☆■-U2

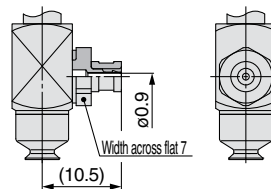

M-5AU-2 [Weight: 1.5 g]<sup>\*2</sup>

ZP3-Y04UM□☆■-U4  
ZP3-Y06UM□☆■-U4  
ZP3-Y08UM□☆■-U4

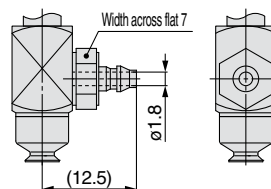

M-5AU-4-X83 [Weight: 1.6 g]<sup>\*2</sup>

### One-touch fitting

ZP3-Y04UM□☆■-02  
ZP3-Y06UM□☆■-02  
ZP3-Y08UM□☆■-02

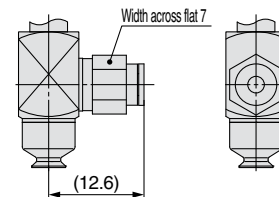

KJH02-M5 [Weight: 1.9 g]<sup>\*2</sup>

ZP3-Y04UM□☆■-04  
ZP3-Y06UM□☆■-04  
ZP3-Y08UM□☆■-04

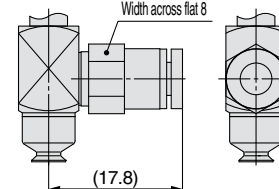

KJH04-M5 [Weight: 2.4 g]<sup>\*2</sup>

\*1 Refer to "ZP3-Y▲▲UM□☆■-B5" for dimensions.

\*2 When calculating the weight, add the weight of the fitting to "ZP3-Y▲▲UM□☆■-B5".

Pad diameter  $\phi 4$  to  $\phi 8$

Pad type Flat with groove

Stroke 15, 20 mm

Dimensions/With Buffer: Vacuum Inlet **Lateral**

Pad Unit

Vertical

With Adapter: Vacuum Inlet

Vertical

With Buffer: Vacuum Inlet

Lateral

With Adapter: Vacuum Inlet

Lateral

With Buffer: Vacuum Inlet

Construction

Adapter Applicable Pad List

Buffer Applicable Pad List

Mounting Adapter Part No.

Buffer Assembly Part No.

ZP3-Y04UM  $\square$ JB  $\blacksquare$ -B5

ZP3-Y04UM  $\square$ K  $\blacksquare$ -B5

ZP3-Y06UM  $\square$ JB  $\blacksquare$ -B5

ZP3-Y06UM  $\square$ K  $\blacksquare$ -B5

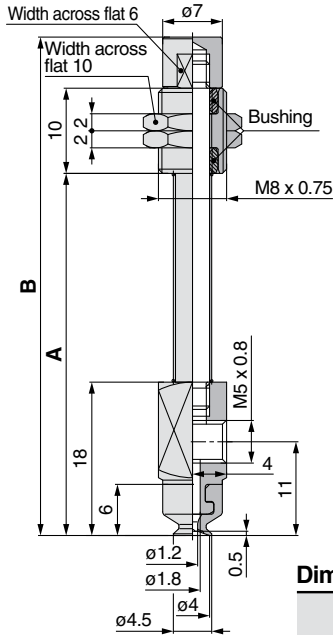

Dimensions (per stroke)

Model	A	B	Weight (g)	
			Non-rotating (J)	Rotating (K)
ZP3-Y04UM $\square$ ☆15-B5	42.5	59	14.3	15.5
ZP3-Y04UM $\square$ ☆20-B5	50	66.5	15.1	16.6

Note 1)  $\square$  in the table indicates the pad material "N, S, U, F, GN, GS."

Note 2) The symbol "☆" indicates buffer type "JB" or "K".

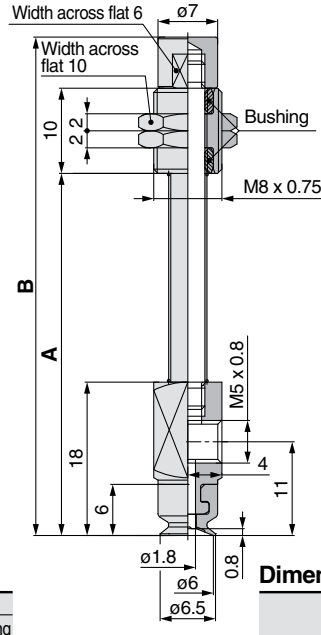

Dimensions (per stroke)

Model	A	B	Weight (g)	
			Non-rotating (J)	Rotating (K)
ZP3-Y06UM $\square$ ☆15-B5	42.5	59	14.3	15.5
ZP3-Y06UM $\square$ ☆20-B5	50	66.5	15.1	16.6

Note 1)  $\square$  in the table indicates the pad material "N, S, U, F, GN, GS."

Note 2) The symbol "☆" indicates buffer type "JB" or "K".

ZP3-Y08UM  $\square$ JB  $\blacksquare$ -B5

ZP3-Y08UM  $\square$ K  $\blacksquare$ -B5

Vacuum Inlet Dimensions

Barb fitting

One-touch fitting

ZP3-Y04UM  $\square$ ☆  $\blacksquare$ -U2  
ZP3-Y06UM  $\square$ ☆  $\blacksquare$ -U2  
ZP3-Y08UM  $\square$ ☆  $\blacksquare$ -U2

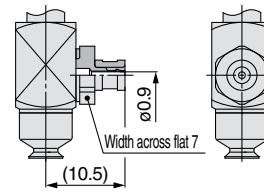

M-5AU-2 [Weight: 1.5 g]<sup>\*2</sup>

ZP3-Y04UM  $\square$ ☆  $\blacksquare$ -U4  
ZP3-Y06UM  $\square$ ☆  $\blacksquare$ -U4  
ZP3-Y08UM  $\square$ ☆  $\blacksquare$ -U4

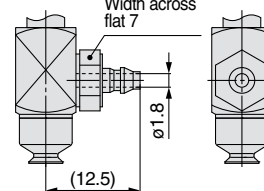

M-5AU-4-X83 [Weight: 1.6 g]<sup>\*2</sup>

ZP3-Y04UM  $\square$ ☆  $\blacksquare$ -02  
ZP3-Y06UM  $\square$ ☆  $\blacksquare$ -02  
ZP3-Y08UM  $\square$ ☆  $\blacksquare$ -02

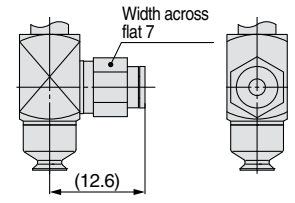

KJH02-M5 [Weight: 1.9 g]<sup>\*2</sup>

ZP3-Y04UM  $\square$ ☆  $\blacksquare$ -04  
ZP3-Y06UM  $\square$ ☆  $\blacksquare$ -04  
ZP3-Y08UM  $\square$ ☆  $\blacksquare$ -04

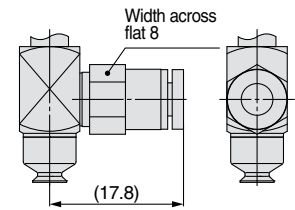

KJH04-M5 [Weight: 2.4 g]<sup>\*2</sup>

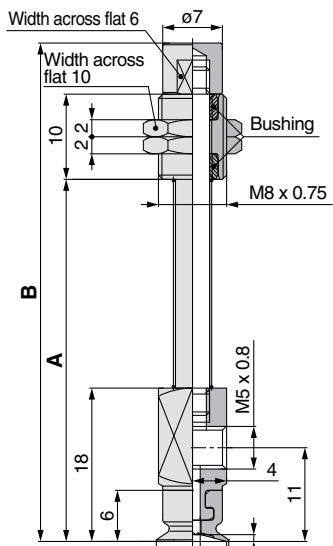

Dimensions (per stroke)

Model	A	B	Weight (g)	
			Non-rotating (J)	Rotating (K)
ZP3-Y08UM $\square$ ☆15-B5	42.5	59	14.3	15.5
ZP3-Y08UM $\square$ ☆20-B5	50	66.5	15.1	16.6

Note 1)  $\square$  in the table indicates the pad material "N, S, U, F, GN, GS."

Note 2) The symbol "☆" indicates buffer type "JB" or "K".

\*1 Refer to "ZP3-Y▲▲UM  $\square$ ☆  $\blacksquare$ -B5" for dimensions.

\*2 When calculating the weight, add the weight of the fitting to "ZP3-Y▲▲UM  $\square$ ☆  $\blacksquare$ -B5".

Pad diameter  $\phi 10$  to  $\phi 16$

Pad type Flat with groove

Stroke 3, 6, 10 mm

## Dimensions/With Buffer: Vacuum Inlet **Lateral**

ZP3-Y10UM□J■-B5

ZP3-Y10UM□K■-B5

ZP3-Y13UM□J■-B5

ZP3-Y13UM□K■-B5

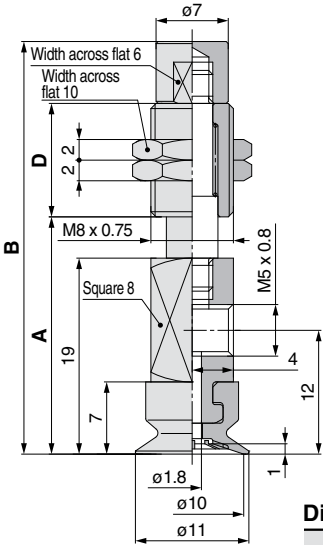

Dimensions (per stroke)

Model	A	B	D	Weight (g)	
				Non-rotating (J)	Rotating (K)
ZP3-Y10UM□☆3-B5	23.5	41	11	13.6	13.0
ZP3-Y10UM□☆6-B5	26	47	14.5	14.9	14.2
ZP3-Y10UM□☆10-B5	30	57	20.5	17.3	16.1

Note 1) □ in the table indicates the pad material "N, S, U, F, GN, GS."  
Note 2) The symbol "☆" indicates buffer type "J" or "K".

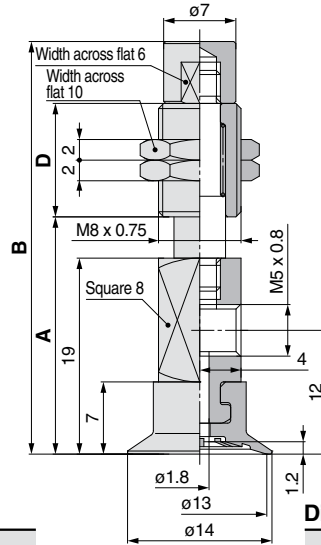
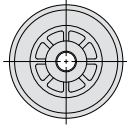

Dimensions (per stroke)

Model	A	B	D	Weight (g)	
				Non-rotating (J)	Rotating (K)
ZP3-Y13UM□☆3-B5	23.5	41	11	13.7	13.1
ZP3-Y13UM□☆6-B5	26	47	14.5	15.0	14.3
ZP3-Y13UM□☆10-B5	30	57	20.5	17.4	16.2

Note 1) □ in the table indicates the pad material "N, S, U, F, GN, GS."  
Note 2) The symbol "☆" indicates buffer type "J" or "K".

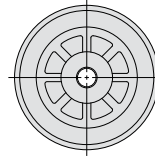

ZP3-Y16UM□J■-B5

ZP3-Y16UM□K■-B5

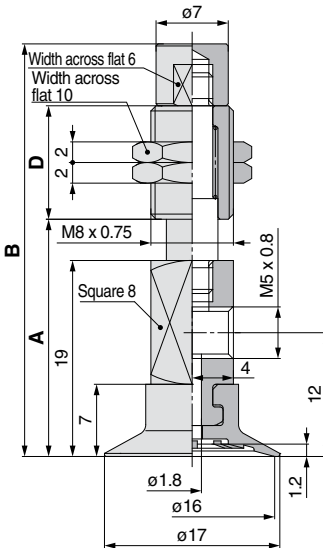

Dimensions (per stroke)

Model	A	B	D	Weight (g)	
				Non-rotating (J)	Rotating (K)
ZP3-Y16UM□☆3-B5	23.5	41	11	13.8	13.2
ZP3-Y16UM□☆6-B5	26	47	14.5	15.1	14.4
ZP3-Y16UM□☆10-B5	30	57	20.5	17.5	16.3

Note 1) □ in the table indicates the pad material "N, S, U, F, GN, GS."  
Note 2) The symbol "☆" indicates buffer type "J" or "K".

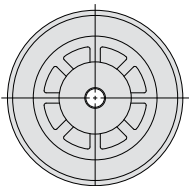

## Vacuum Inlet Dimensions

### Barb fitting

ZP3-Y10UM□☆■-U2  
ZP3-Y13UM□☆■-U2  
ZP3-Y16UM□☆■-U2

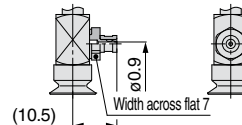

M-5AU-2 [Weight: 1.5 g]<sup>\*2</sup>

ZP3-Y10UM□☆■-U4  
ZP3-Y13UM□☆■-U4  
ZP3-Y16UM□☆■-U4

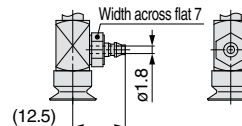

M-5AU-4-X83 [Weight: 1.6 g]<sup>\*2</sup>

ZP3-Y10UM□☆■-U6  
ZP3-Y13UM□☆■-U6  
ZP3-Y16UM□☆■-U6

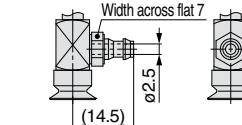

M-5AU-6-X83 [Weight: 1.8 g]<sup>\*2</sup>

### One-touch fitting

ZP3-Y10UM□☆■-02  
ZP3-Y13UM□☆■-02  
ZP3-Y16UM□☆■-02

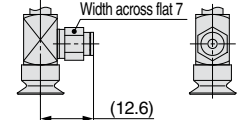

KJH02-M5 [Weight: 1.9 g]<sup>\*2</sup>

ZP3-Y10UM□☆■-04  
ZP3-Y13UM□☆■-04  
ZP3-Y16UM□☆■-04

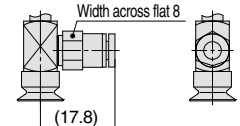

KJH04-M5 [Weight: 2.4 g]<sup>\*2</sup>

ZP3-Y10UM□☆■-06  
ZP3-Y13UM□☆■-06  
ZP3-Y16UM□☆■-06

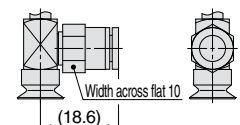

KJH06-M5 [Weight: 3.3 g]<sup>\*2</sup>

\*1 Refer to "ZP3-Y▲▲UM□☆■-B5" for dimensions.

\*2 When calculating the weight, add the weight of the fitting to "ZP3-Y▲▲UM□☆■-B5".

Pad diameter  $\phi 10$  to  $\phi 16$

Pad type Flat with groove

Stroke 15, 20 mm

Dimensions/With Buffer: Vacuum Inlet **Lateral**

ZP3-Y10UM  $\square$  JB  $\blacksquare$  B5

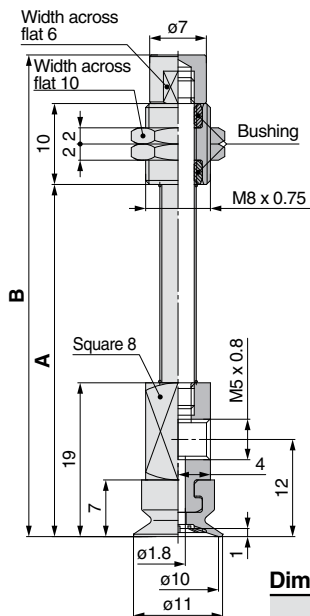

ZP3-Y10UM  $\square$  K  $\blacksquare$  B5

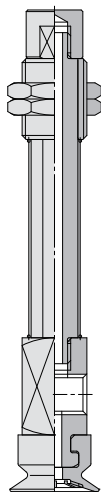

ZP3-Y13UM  $\square$  JB  $\blacksquare$  B5

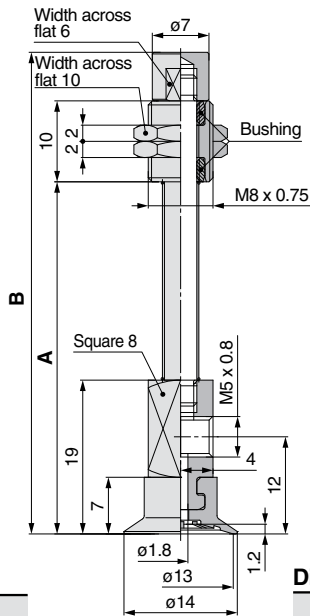

ZP3-Y13UM  $\square$  K  $\blacksquare$  B5

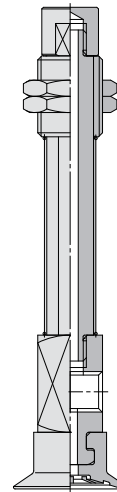

Dimensions (per stroke)

Model	A	B	Weight (g)	
			Non-rotating (J)	Rotating (K)
ZP3-Y10UM $\square$ $\star$ 15-B5	43.5	60	15.0	16.2
ZP3-Y10UM $\square$ $\star$ 20-B5	51	67.5	15.8	17.3

Note 1)  $\square$  in the table indicates the pad material "N, S, U, F, GN, GS."  
Note 2) The symbol " $\star$ " indicates buffer type "JB" or "K".

Dimensions (per stroke)

Model	A	B	Weight (g)	
			Non-rotating (J)	Rotating (K)
ZP3-Y13UM $\square$ $\star$ 15-B5	43.5	60	15.1	16.3
ZP3-Y13UM $\square$ $\star$ 20-B5	51	67.5	15.9	17.4

Note 1)  $\square$  in the table indicates the pad material "N, S, U, F, GN, GS."  
Note 2) The symbol " $\star$ " indicates buffer type "JB" or "K".

ZP3-Y16UM  $\square$  JB  $\blacksquare$  B5

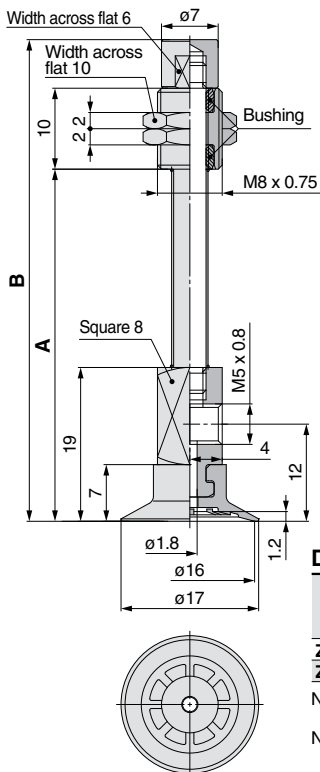

ZP3-Y16UM  $\square$  K  $\blacksquare$  B5

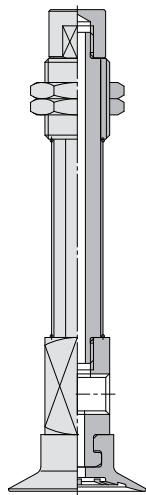

Dimensions (per stroke)

Model	A	B	Weight (g)	
			Non-rotating (J)	Rotating (K)
ZP3-Y16UM $\square$ $\star$ 15-B5	43.5	60	15.2	16.4
ZP3-Y16UM $\square$ $\star$ 20-B5	51	67.5	16.0	17.5

Note 1)  $\square$  in the table indicates the pad material "N, S, U, F, GN, GS."  
Note 2) The symbol " $\star$ " indicates buffer type "JB" or "K".

Vacuum Inlet Dimensions

Barb fitting

One-touch fitting

ZP3-Y10UM  $\square$   $\star$   $\blacksquare$  U2  
ZP3-Y13UM  $\square$   $\star$   $\blacksquare$  U2  
ZP3-Y16UM  $\square$   $\star$   $\blacksquare$  U2

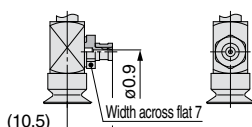

M-5AU-2 [Weight: 1.5 g]<sup>\*2</sup>

ZP3-Y10UM  $\square$   $\star$   $\blacksquare$  U4  
ZP3-Y13UM  $\square$   $\star$   $\blacksquare$  U4  
ZP3-Y16UM  $\square$   $\star$   $\blacksquare$  U4

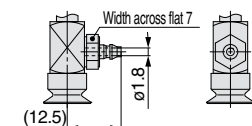

M-5AU-4-X83 [Weight: 1.6 g]<sup>\*2</sup>

ZP3-Y10UM  $\square$   $\star$   $\blacksquare$  U6  
ZP3-Y13UM  $\square$   $\star$   $\blacksquare$  U6  
ZP3-Y16UM  $\square$   $\star$   $\blacksquare$  U6

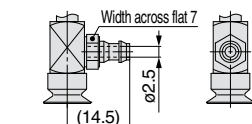

M-5AU-6-X83 [Weight: 1.8 g]<sup>\*2</sup>

ZP3-Y10UM  $\square$   $\star$   $\blacksquare$  O2  
ZP3-Y13UM  $\square$   $\star$   $\blacksquare$  O2  
ZP3-Y16UM  $\square$   $\star$   $\blacksquare$  O2

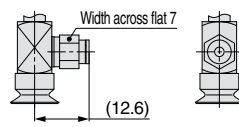

KJH02-M5 [Weight: 1.9 g]<sup>\*2</sup>

ZP3-Y10UM  $\square$   $\star$   $\blacksquare$  O4  
ZP3-Y13UM  $\square$   $\star$   $\blacksquare$  O4  
ZP3-Y16UM  $\square$   $\star$   $\blacksquare$  O4

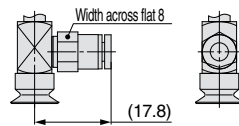

KJH04-M5 [Weight: 2.4 g]<sup>\*2</sup>

ZP3-Y10UM  $\square$   $\star$   $\blacksquare$  O6  
ZP3-Y13UM  $\square$   $\star$   $\blacksquare$  O6  
ZP3-Y16UM  $\square$   $\star$   $\blacksquare$  O6

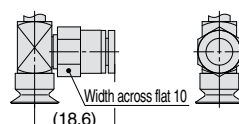

KJH06-M5 [Weight: 3.3 g]<sup>\*2</sup>

\*1 Refer to "ZP3-Y  $\blacktriangle$   $\blacktriangle$  UM  $\square$   $\star$   $\blacksquare$  B5" for dimensions.

\*2 When calculating the weight, add the weight of the fitting to "ZP3-Y  $\blacktriangle$   $\blacktriangle$  UM  $\square$   $\star$   $\blacksquare$  B5".

Pad Unit

Vertical

With Adapter:  
Vacuum Inlet

Vertical

With Buffer:  
Vacuum Inlet

Lateral

With Adapter:  
Vacuum Inlet

Lateral

With Buffer:  
Vacuum Inlet

Vertical

Construction

Adapter Applicable  
Pad List

Buffer Applicable  
Pad List

Mounting Adapter  
Part No.

Buffer Assembly  
Part No.

Pad diameter  $\phi 4$  to  $\phi 8$

Pad type Bellows

Stroke 3, 6, 10 mm

## Dimensions/With Buffer: Vacuum Inlet **Lateral**

ZP3-Y04B□J■-B5

ZP3-Y04B□K■-B5

ZP3-Y06B□J■-B5

ZP3-Y06B□K■-B5

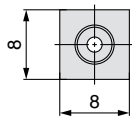
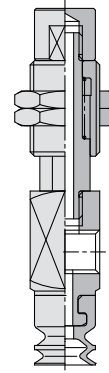
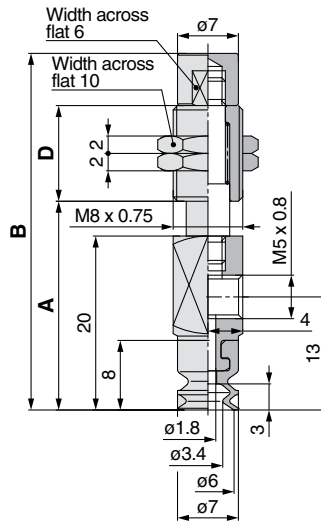
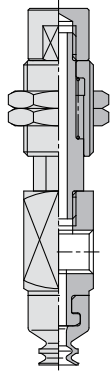
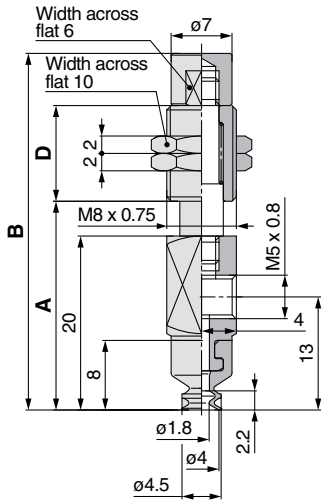

### Dimensions (per stroke)

Model	A	B	D	Weight (g)	
				Non-rotating (J)	Rotating (K)
ZP3-Y04B□☆3-B5	24.5	42	11	12.8	12.2
ZP3-Y04B□☆6-B5	27	48	14.5	14.2	13.4
ZP3-Y04B□☆10-B5	31	58	20.5	16.6	15.4

Note 1) □ in the table indicates the pad material "N, S, U, F, GN, GS."

Note 2) The symbol "☆" indicates buffer type "J" or "K".

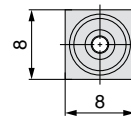

### Dimensions (per stroke)

Model	A	B	D	Weight (g)	
				Non-rotating (J)	Rotating (K)
ZP3-Y06B□☆3-B5	24.5	42	11	12.8	12.2
ZP3-Y06B□☆6-B5	27	48	14.5	14.2	13.4
ZP3-Y06B□☆10-B5	31	58	20.5	16.6	15.4

Note 1) □ in the table indicates the pad material "N, S, U, F, GN, GS."

Note 2) The symbol "☆" indicates buffer type "J" or "K".

ZP3-Y08B□J■-B5

ZP3-Y08B□K■-B5

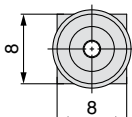
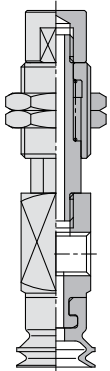
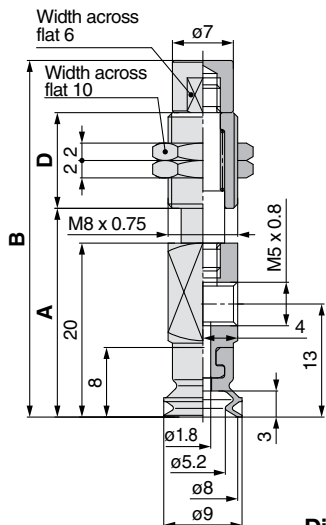

### Dimensions (per stroke)

Model	A	B	D	Weight (g)	
				Non-rotating (J)	Rotating (K)
ZP3-Y08B□☆3-B5	24.5	42	11	12.9	12.3
ZP3-Y08B□☆6-B5	27	48	14.5	14.3	13.5
ZP3-Y08B□☆10-B5	31	58	20.5	16.7	15.5

Note 1) □ in the table indicates the pad material "N, S, U, F, GN, GS."

Note 2) The symbol "☆" indicates buffer type "J" or "K".

## Vacuum Inlet Dimensions

### Barb fitting

ZP3-Y04B□☆■-U2  
ZP3-Y06B□☆■-U2  
ZP3-Y08B□☆■-U2

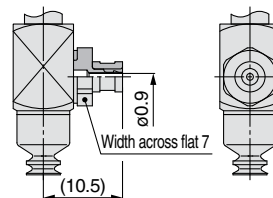

M-5AU-2 [Weight: 1.5 g]<sup>\*2</sup>

ZP3-Y04B□☆■-U4  
ZP3-Y06B□☆■-U4  
ZP3-Y08B□☆■-U4

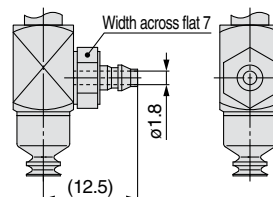

M-5AU-4-X83 [Weight: 1.6 g]<sup>\*2</sup>

### One-touch fitting

ZP3-Y04B□☆■-02  
ZP3-Y06B□☆■-02  
ZP3-Y08B□☆■-02

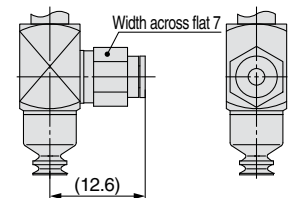

KJH02-M5 [Weight: 1.9 g]<sup>\*2</sup>

ZP3-Y04B□☆■-04  
ZP3-Y06B□☆■-04  
ZP3-Y08B□☆■-04

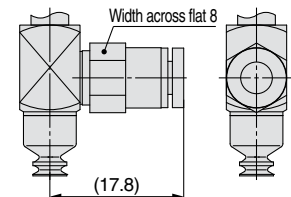

KJH04-M5 [Weight: 2.4 g]<sup>\*2</sup>

\*1 Refer to "ZP3-Y▲▲B□☆■-B5" for dimensions.

\*2 When calculating the weight, add the weight of the fitting to "ZP3-Y▲▲B□☆■-B5".

Pad diameter  $\phi 4$  to  $\phi 8$

Pad type **Bellows**

Stroke **15, 20 mm**

Dimensions/With Buffer: Vacuum Inlet **Lateral**

ZP3-Y04B□JB■-B5

ZP3-Y04B□K■-B5

ZP3-Y06B□JB■-B5

ZP3-Y06B□K■-B5

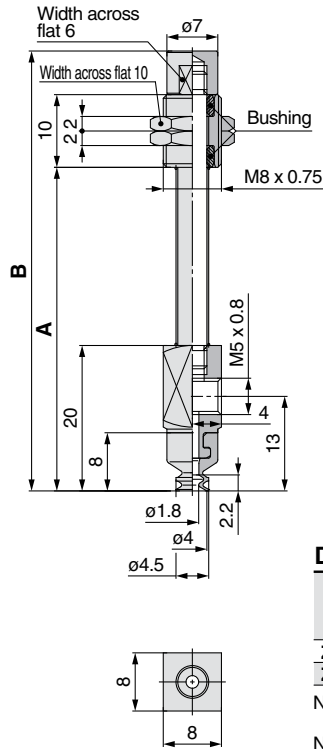

Dimensions (per stroke)

Model	A	B	Weight (g)	
			Non-rotating (J)	Rotating (K)
ZP3-Y04B□☆15-B5	44.5	61	14.3	15.5
ZP3-Y04B□☆20-B5	52	68.5	15.1	16.6

Note 1) □ in the table indicates the pad material "N, S, U, F, GN, GS."  
 Note 2) The symbol "☆" indicates buffer type "JB" or "K".

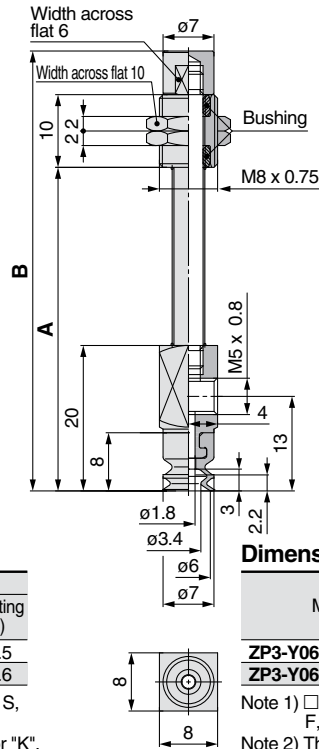

Dimensions (per stroke)

Model	A	B	Weight (g)	
			Non-rotating (J)	Rotating (K)
ZP3-Y06B□☆15-B5	44.5	61	14.3	15.5
ZP3-Y06B□☆20-B5	52	68.5	15.1	16.6

Note 1) □ in the table indicates the pad material "N, S, U, F, GN, GS."  
 Note 2) The symbol "☆" indicates buffer type "JB" or "K".

ZP3-Y08B□JB■-B5

ZP3-Y08B□K■-B5

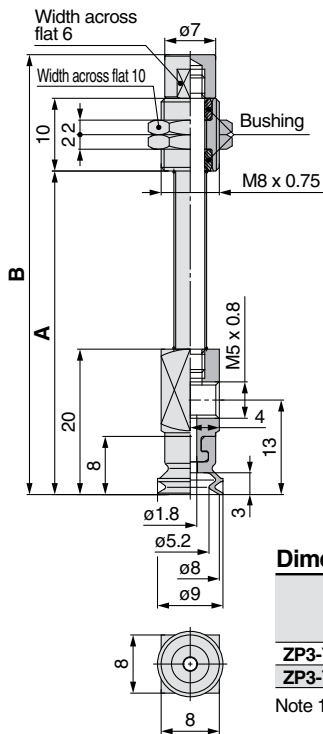

Dimensions (per stroke)

Model	A	B	Weight (g)	
			Non-rotating (J)	Rotating (K)
ZP3-Y08B□☆15-B5	44.5	61	14.4	15.6
ZP3-Y08B□☆20-B5	52	68.5	15.2	16.7

Note 1) □ in the table indicates the pad material "N, S, U, F, GN, GS."  
 Note 2) The symbol "☆" indicates buffer type "JB" or "K".

Vacuum Inlet Dimensions

Barb fitting

ZP3-Y04B□☆■-U2  
 ZP3-Y06B□☆■-U2  
 ZP3-Y08B□☆■-U2

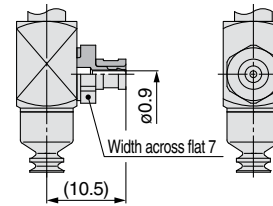

M-5AU-2 [Weight: 1.5 g]<sup>\*2</sup>

ZP3-Y04B□☆■-U4  
 ZP3-Y06B□☆■-U4  
 ZP3-Y08B□☆■-U4

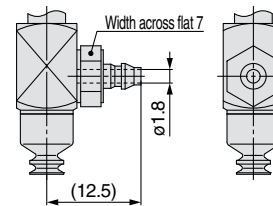

M-5AU-4-X83 [Weight: 1.6 g]<sup>\*2</sup>

One-touch fitting

ZP3-Y04B□☆■-02  
 ZP3-Y06B□☆■-02  
 ZP3-Y08B□☆■-02

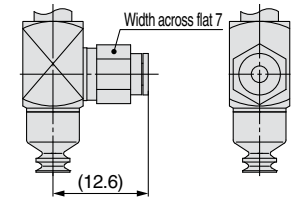

KJH02-M5 [Weight: 1.9 g]<sup>\*2</sup>

ZP3-Y04B□☆■-04  
 ZP3-Y06B□☆■-04  
 ZP3-Y08B□☆■-04

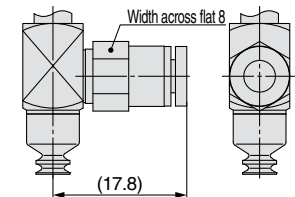

KJH04-M5 [Weight: 2.4 g]<sup>\*2</sup>

\*1 Refer to "ZP3-Y▲▲B□☆■-B5" for dimensions.

\*2 When calculating the weight, add the weight of the fitting to "ZP3-Y▲▲B□☆■-B5".



Pad diameter  $\varnothing 10$  to  $\varnothing 16$

Pad type **Bellows**

Stroke **3, 6, 10 mm**

## Dimensions/With Buffer: Vacuum Inlet **Lateral**

ZP3-Y10B□J■■■-B5

ZP3-Y10B□K■■■-B5

ZP3-Y13B□J■■■-B5

ZP3-Y13B□K■■■-B5

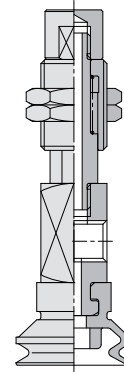
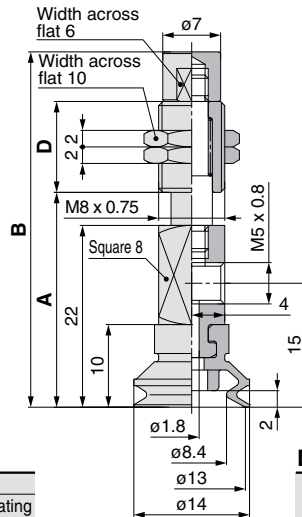
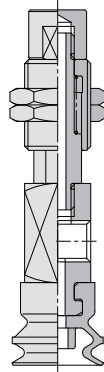
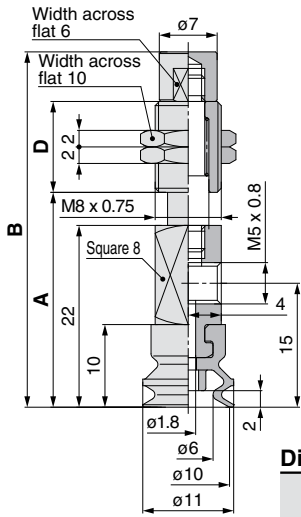

Dimensions (per stroke)

Model	A	B	D	Weight (g)	
				Non-rotating (J)	Rotating (K)
ZP3-Y10B□☆3-B5	26.5	44	11	13.8	13.2
ZP3-Y10B□☆6-B5	29	50	14.5	15.1	14.2
ZP3-Y10B□☆10-B5	33	60	20.5	17.5	16.3

Note 1) □ in the table indicates the pad material "N, S, U, F, GN, GS."  
Note 2) The symbol "☆" indicates buffer type "J" or "K".

Dimensions (per stroke)

Model	A	B	D	Weight (g)	
				Non-rotating (J)	Rotating (K)
ZP3-Y13B□☆3-B5	26.5	44	11	14.0	13.4
ZP3-Y13B□☆6-B5	29	50	14.5	15.3	14.4
ZP3-Y13B□☆10-B5	33	60	20.5	17.7	16.5

Note 1) □ in the table indicates the pad material "N, S, U, F, GN, GS."  
Note 2) The symbol "☆" indicates buffer type "J" or "K".

ZP3-Y16B□J■■■-B5

ZP3-Y16B□K■■■-B5

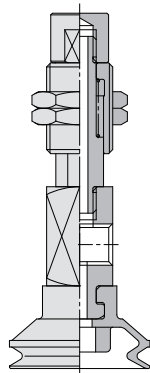
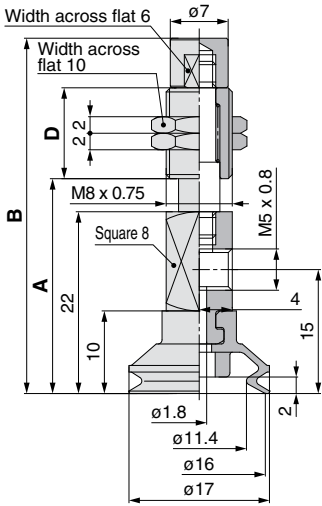

Dimensions (per stroke)

Model	A	B	D	Weight (g)	
				Non-rotating (J)	Rotating (K)
ZP3-Y16B□☆3-B5	26.5	44	11	14.1	13.5
ZP3-Y16B□☆6-B5	29	50	14.5	15.4	14.5
ZP3-Y16B□☆10-B5	33	60	20.5	17.8	16.6

Note 1) □ in the table indicates the pad material "N, S, U, F, GN, GS."  
Note 2) The symbol "☆" indicates buffer type "J" or "K".

## Vacuum Inlet Dimensions

Barb fitting

One-touch fitting

ZP3-Y10B□☆■■■-U2  
ZP3-Y13B□☆■■■-U2  
ZP3-Y16B□☆■■■-U2

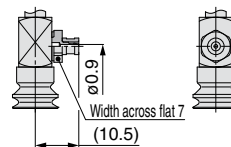

M-5AU-2 [Weight: 1.5 g]\*2

ZP3-Y10B□☆■■■-02  
ZP3-Y13B□☆■■■-02  
ZP3-Y16B□☆■■■-02

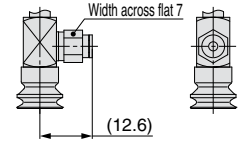

KJH02-M5 [Weight: 1.9 g]\*2

ZP3-Y10B□☆■■■-U4  
ZP3-Y13B□☆■■■-U4  
ZP3-Y16B□☆■■■-U4

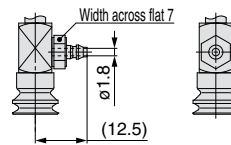

M-5AU-4-X83 [Weight: 1.6 g]\*2

ZP3-Y10B□☆■■■-04  
ZP3-Y13B□☆■■■-04  
ZP3-Y16B□☆■■■-04

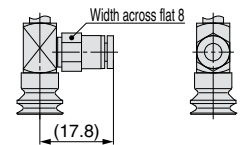

KJH04-M5 [Weight: 2.4 g]\*2

ZP3-Y10B□☆■■■-U6  
ZP3-Y13B□☆■■■-U6  
ZP3-Y16B□☆■■■-U6

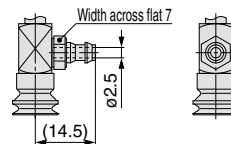

M-5AU-6-X83 [Weight: 1.8 g]\*2

ZP3-Y10B□☆■■■-06  
ZP3-Y13B□☆■■■-06  
ZP3-Y16B□☆■■■-06

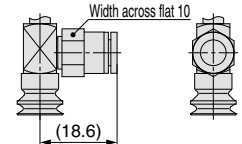

KJH06-M5 [Weight: 3.3 g]\*2

\*1 Refer to "ZP3-Y▲▲B□☆■■■-B5" for dimensions.

\*2 When calculating the weight, add the weight of the fitting to "ZP3-Y▲▲B□☆■■■-B5".

Pad diameter  $\varnothing 10$  to  $\varnothing 16$

Pad type **Bellows**

Stroke **15, 20 mm**

Dimensions/With Buffer: Vacuum Inlet **Lateral**

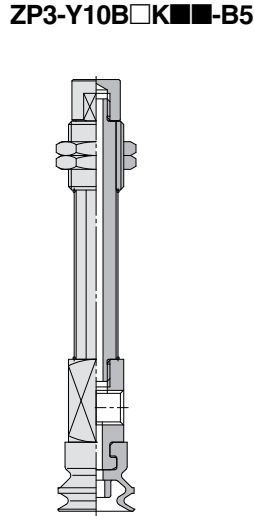
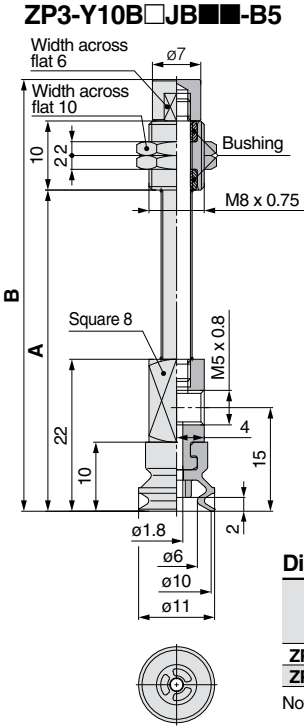

Dimensions (per stroke)

Model	A	B	Weight (g)	
			Non-rotating (J)	Rotating (K)
ZP3-Y10B $\square$ $\star$ 15-B5	46.5	63	15.2	16.4
ZP3-Y10B $\square$ $\star$ 20-B5	54	70.5	16.0	17.5

Note 1)  $\square$  in the table indicates the pad material "N, S, U, F, GN, GS."  
 Note 2) The symbol " $\star$ " indicates buffer type "JB" or "K".

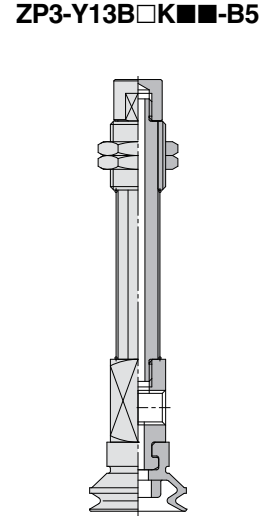
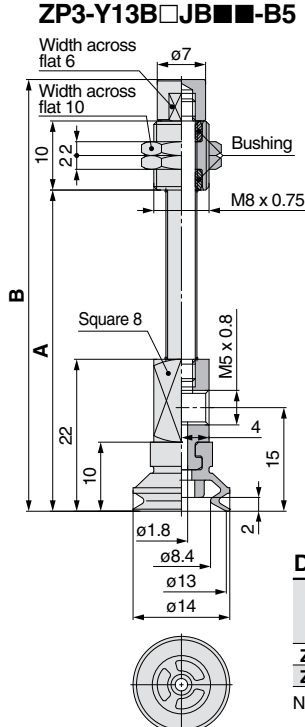

Dimensions (per stroke)

Model	A	B	Weight (g)	
			Non-rotating (J)	Rotating (K)
ZP3-Y13B $\square$ $\star$ 15-B5	46.5	63	15.4	16.6
ZP3-Y13B $\square$ $\star$ 20-B5	54	70.5	16.2	17.7

Note 1)  $\square$  in the table indicates the pad material "N, S, U, F, GN, GS."  
 Note 2) The symbol " $\star$ " indicates buffer type "JB" or "K".

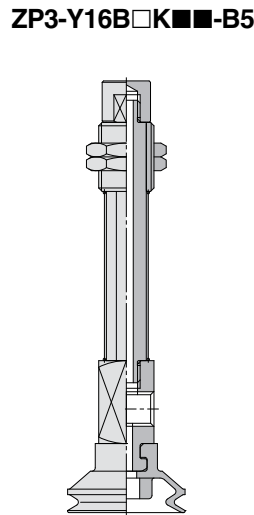
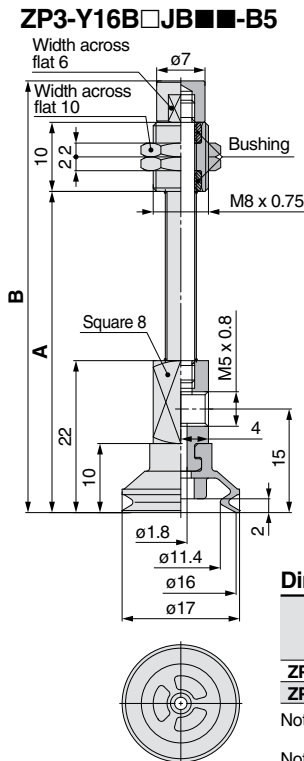

Dimensions (per stroke)

Model	A	B	Weight (g)	
			Non-rotating (J)	Rotating (K)
ZP3-Y16B $\square$ $\star$ 15-B5	46.5	63	15.5	16.7
ZP3-Y16B $\square$ $\star$ 20-B5	54	70.5	16.3	17.8

Note 1)  $\square$  in the table indicates the pad material "N, S, U, F, GN, GS."  
 Note 2) The symbol " $\star$ " indicates buffer type "JB" or "K".

Vacuum Inlet Dimensions

Barb fitting	One-touch fitting
<p>ZP3-Y10B <math>\square</math> <math>\star</math> <math>\blacksquare</math> <b>-U2</b>                      ZP3-Y13B <math>\square</math> <math>\star</math> <math>\blacksquare</math> <b>-U2</b>                      ZP3-Y16B <math>\square</math> <math>\star</math> <math>\blacksquare</math> <b>-U2</b></p> <p><b>M-5AU-2</b> [Weight: 1.5 g]<sup>*2</sup></p>	<p>ZP3-Y10B <math>\square</math> <math>\star</math> <math>\blacksquare</math> <b>-02</b>                      ZP3-Y13B <math>\square</math> <math>\star</math> <math>\blacksquare</math> <b>-02</b>                      ZP3-Y16B <math>\square</math> <math>\star</math> <math>\blacksquare</math> <b>-02</b></p> <p><b>KJH02-M5</b> [Weight: 1.9 g]<sup>*2</sup></p>
<p>ZP3-Y10B <math>\square</math> <math>\star</math> <math>\blacksquare</math> <b>-U4</b>                      ZP3-Y13B <math>\square</math> <math>\star</math> <math>\blacksquare</math> <b>-U4</b>                      ZP3-Y16B <math>\square</math> <math>\star</math> <math>\blacksquare</math> <b>-U4</b></p> <p><b>M-5AU-4-X83</b> [Weight: 1.6 g]<sup>*2</sup></p>	<p>ZP3-Y10B <math>\square</math> <math>\star</math> <math>\blacksquare</math> <b>-04</b>                      ZP3-Y13B <math>\square</math> <math>\star</math> <math>\blacksquare</math> <b>-04</b>                      ZP3-Y16B <math>\square</math> <math>\star</math> <math>\blacksquare</math> <b>-04</b></p> <p><b>KJH04-M5</b> [Weight: 2.4 g]<sup>*2</sup></p>
<p>ZP3-Y10B <math>\square</math> <math>\star</math> <math>\blacksquare</math> <b>-U6</b>                      ZP3-Y13B <math>\square</math> <math>\star</math> <math>\blacksquare</math> <b>-U6</b>                      ZP3-Y16B <math>\square</math> <math>\star</math> <math>\blacksquare</math> <b>-U6</b></p> <p><b>M-5AU-6-X83</b> [Weight: 1.8 g]<sup>*2</sup></p>	<p>ZP3-Y10B <math>\square</math> <math>\star</math> <math>\blacksquare</math> <b>-06</b>                      ZP3-Y13B <math>\square</math> <math>\star</math> <math>\blacksquare</math> <b>-06</b>                      ZP3-Y16B <math>\square</math> <math>\star</math> <math>\blacksquare</math> <b>-06</b></p> <p><b>KJH06-M5</b> [Weight: 3.3 g]<sup>*2</sup></p>

\*1 Refer to "ZP3-Y $\blacktriangle$  $\blacktriangle$ B  $\square$   $\star$   $\blacksquare$  **-B5**" for dimensions.  
 \*2 When calculating the weight, add the weight of the fitting to "ZP3-Y $\blacktriangle$  $\blacktriangle$ B  $\square$   $\star$   $\blacksquare$  **-B5**".

Pad Unit  
 Vertical  
 With Adapter: Vacuum Inlet  
 Vertical  
 With Buffer: Vacuum Inlet  
 Lateral  
 With Adapter: Vacuum Inlet  
 Lateral  
 With Buffer: Vacuum Inlet  
 Lateral  
 With Buffer: Vacuum Inlet  
 Construction  
 Adapter Applicable Pad List  
 Buffer Applicable Pad List  
 Mounting Adapter Part No.  
 Buffer Assembly Part No.



# Series ZP3 Construction

## Component Parts List

### Pad with adapter

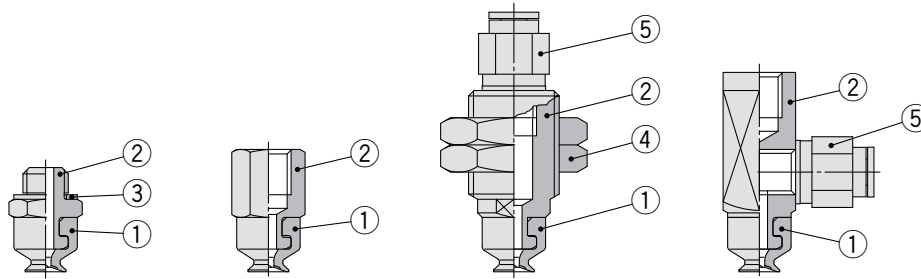

### Component Parts

No.	Description	Material (Surface treatment)	Note
1	Pad	NBR/Silicone rubber Urethane rubber/FKM Conductive NBR/Conductive silicone rubber	
2	Adapter	Brass(Electroless nickel plated)	
3	Gasket	Stainless steel 304/NBR	
4	Nut	Structural steel(Trivalent chromated)	M6 x 0.75 M8 x 0.75 M12 x 1
		Brass(Nickel plated)	M10 x 1
5	Fitting	—	

### Pad with buffer

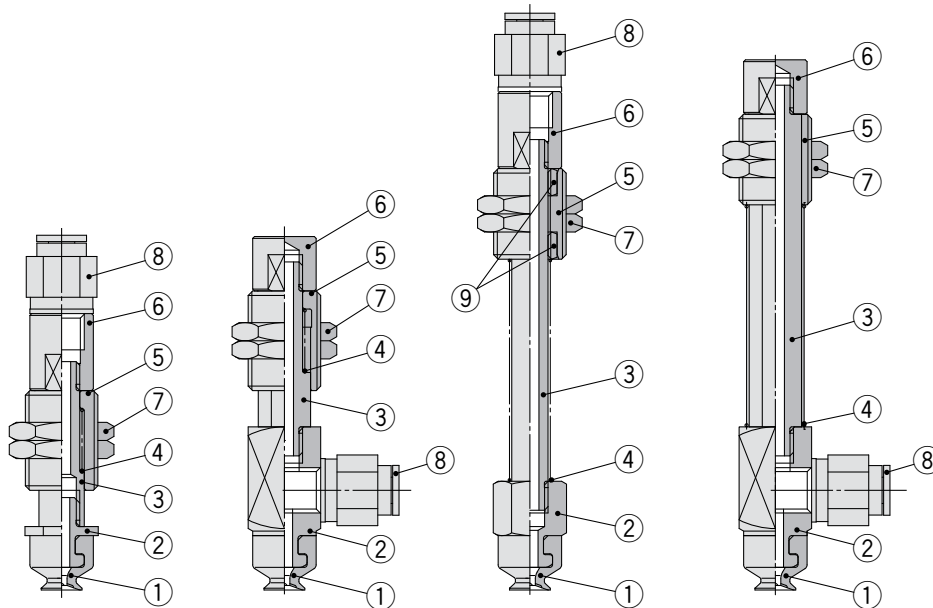







### Component Parts





No.	Description	Material (Surface treatment)	Note
1	Pad	NBR/Silicone rubber Urethane rubber/FKM Conductive NBR/Conductive silicone rubber	
2	Adapter	Brass(Electroless nickel plated)	
3	Piston rod	Stainless steel	
4	Return spring	Stainless steel	
5	Buffer body	Brass(Electroless nickel plated)	
6	Buffer adapter	Brass(Electroless nickel plated)	
7	Nut	Structural steel(Trivalent chromated)	
8	Fitting	—	
9	Bushing	—	

# Series ZP3

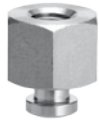
# Adapter Applicable Pad List

## Series ZP3 Mounting Adapter Part No.

Adapter part no.	Applicable pad part no. Series ZP3	Page
	ZP3-015U□ ZP3-02U□ ZP3-035U□	P.47
	ZP3-015U□ ZP3-02U□ ZP3-035U□	P.47
	ZP3-04UM□ ZP3-06UM□ ZP3-08UM□ ZP3-04B□ ZP3-06B□ ZP3-08B□	P.47
	ZP3-04UM□ ZP3-06UM□ ZP3-08UM□ ZP3-04B□ ZP3-06B□ ZP3-08B□	P.47
	ZP3-04UM□ ZP3-06UM□ ZP3-08UM□ ZP3-04B□ ZP3-06B□ ZP3-08B□	P.47
	ZP3-04UM□ ZP3-06UM□ ZP3-08UM□ ZP3-04B□ ZP3-06B□ ZP3-08B□	P.47
	ZP3-10UM□ ZP3-13UM□ ZP3-16UM□ ZP3-10B□ ZP3-13B□ ZP3-16B□	P.47
	ZP3-10UM□ ZP3-13UM□ ZP3-16UM□ ZP3-10B□ ZP3-13B□ ZP3-16B□	P.48

Adapter part no.	Applicable pad part no. Series ZP3	Page
	ZP3-10UM□ ZP3-13UM□ ZP3-16UM□ ZP3-10B□ ZP3-13B□ ZP3-16B□	P.48
	ZP3-10UM□ ZP3-13UM□ ZP3-16UM□ ZP3-10B□ ZP3-13B□ ZP3-16B□	P.48
	ZP3-015U□ ZP3-02U□ ZP3-035U□	P.48
	ZP3-04UM□ ZP3-06UM□ ZP3-08UM□ ZP3-04B□ ZP3-06B□ ZP3-08B□	P.48
	ZP3-10UM□ ZP3-13UM□ ZP3-16UM□ ZP3-10B□ ZP3-13B□ ZP3-16B□	P.48

Pad Unit

Vertical  
With Adapter:  
Vacuum Inlet

Vertical  
With Buffer:  
Vacuum Inlet

Lateral  
With Adapter:  
Vacuum Inlet

Lateral  
With Buffer:  
Vacuum Inlet

Construction

Adapter Applicable  
Pad List

Buffer Applicable  
Pad List

Mounting Adapter  
Part No.

Buffer Assembly  
Part No.

# Series ZP3



# Buffer Applicable Pad List



Buffer Assembly Part No.

Buffer assembly part no.	Applicable pad part no. Series ZP3	Page
ZP3B-T1J3-B3	ZP3-015U□ ZP3-02U□ ZP3-035U□	P.49
ZP3B-T1J6-B3	ZP3-015U□ ZP3-02U□ ZP3-035U□	P.49
ZP3B-T1K3-B3	ZP3-015U□ ZP3-02U□ ZP3-035U□	P.49
ZP3B-T1K6-B3	ZP3-015U□ ZP3-02U□ ZP3-035U□	P.49
ZP3B-T2AJ3-B5	ZP3-04UM□ ZP3-06UM□ ZP3-08UM□ ZP3-04B□ ZP3-06B□ ZP3-08B□	P.49
ZP3B-T2AJ6-B5	ZP3-04UM□ ZP3-06UM□ ZP3-08UM□ ZP3-04B□ ZP3-06B□ ZP3-08B□	P.49
ZP3B-T2AJ10-B5	ZP3-04UM□ ZP3-06UM□ ZP3-08UM□ ZP3-04B□ ZP3-06B□ ZP3-08B□	P.49

Buffer assembly part no.	Applicable pad part no. Series ZP3	Page
ZP3B-T2AK3-B5	ZP3-04UM□ ZP3-06UM□ ZP3-08UM□ ZP3-04B□ ZP3-06B□ ZP3-08B□	P.49
ZP3B-T2AK6-B5	ZP3-04UM□ ZP3-06UM□ ZP3-08UM□ ZP3-04B□ ZP3-06B□ ZP3-08B□	P.49
ZP3B-T2AK10-B5	ZP3-04UM□ ZP3-06UM□ ZP3-08UM□ ZP3-04B□ ZP3-06B□ ZP3-08B□	P.49
ZP3B-T2AJB15-B5	ZP3-04UM□ ZP3-06UM□ ZP3-08UM□ ZP3-04B□ ZP3-06B□ ZP3-08B□	P.49
ZP3B-T2AJB20-B5	ZP3-04UM□ ZP3-06UM□ ZP3-08UM□ ZP3-04B□ ZP3-06B□ ZP3-08B□	P.49
ZP3B-T2AK15-B5	ZP3-04UM□ ZP3-06UM□ ZP3-08UM□ ZP3-04B□ ZP3-06B□ ZP3-08B□	P.49
ZP3B-T2AK20-B5	ZP3-04UM□ ZP3-06UM□ ZP3-08UM□ ZP3-04B□ ZP3-06B□ ZP3-08B□	P.49

**Buffer Assembly Part No.**

Buffer assembly part no.		Applicable pad part no. Series ZP3	Page
ZP3B-T2BJ3-B5		ZP3-10UM <input type="checkbox"/> ZP3-13UM <input type="checkbox"/> ZP3-16UM <input type="checkbox"/> ZP3-10B <input type="checkbox"/> ZP3-13B <input type="checkbox"/> ZP3-16B <input type="checkbox"/>	P.50
ZP3B-T2BJ6-B5		ZP3-10UM <input type="checkbox"/> ZP3-13UM <input type="checkbox"/> ZP3-16UM <input type="checkbox"/> ZP3-10B <input type="checkbox"/> ZP3-13B <input type="checkbox"/> ZP3-16B <input type="checkbox"/>	P.50
ZP3B-T2BJ10-B5		ZP3-10UM <input type="checkbox"/> ZP3-13UM <input type="checkbox"/> ZP3-16UM <input type="checkbox"/> ZP3-10B <input type="checkbox"/> ZP3-13B <input type="checkbox"/> ZP3-16B <input type="checkbox"/>	P.50
ZP3B-T2BK3-B5		ZP3-10UM <input type="checkbox"/> ZP3-13UM <input type="checkbox"/> ZP3-16UM <input type="checkbox"/> ZP3-10B <input type="checkbox"/> ZP3-13B <input type="checkbox"/> ZP3-16B <input type="checkbox"/>	P.50
ZP3B-T2BK6-B5		ZP3-10UM <input type="checkbox"/> ZP3-13UM <input type="checkbox"/> ZP3-16UM <input type="checkbox"/> ZP3-10B <input type="checkbox"/> ZP3-13B <input type="checkbox"/> ZP3-16B <input type="checkbox"/>	P.50
ZP3B-T2BK10-B5		ZP3-10UM <input type="checkbox"/> ZP3-13UM <input type="checkbox"/> ZP3-16UM <input type="checkbox"/> ZP3-10B <input type="checkbox"/> ZP3-13B <input type="checkbox"/> ZP3-16B <input type="checkbox"/>	P.50
ZP3B-T2BJB15-B5		ZP3-10UM <input type="checkbox"/> ZP3-13UM <input type="checkbox"/> ZP3-16UM <input type="checkbox"/> ZP3-10B <input type="checkbox"/> ZP3-13B <input type="checkbox"/> ZP3-16B <input type="checkbox"/>	P.50
ZP3B-T2BJB20-B5		ZP3-10UM <input type="checkbox"/> ZP3-13UM <input type="checkbox"/> ZP3-16UM <input type="checkbox"/> ZP3-10B <input type="checkbox"/> ZP3-13B <input type="checkbox"/> ZP3-16B <input type="checkbox"/>	P.50

Buffer assembly part no.		Applicable pad part no. Series ZP3	Page
ZP3B-T2BK15-B5		ZP3-10UM <input type="checkbox"/> ZP3-13UM <input type="checkbox"/> ZP3-16UM <input type="checkbox"/> ZP3-10B <input type="checkbox"/> ZP3-13B <input type="checkbox"/> ZP3-16B <input type="checkbox"/>	P.50
ZP3B-T2BK20-B5		ZP3-10UM <input type="checkbox"/> ZP3-13UM <input type="checkbox"/> ZP3-16UM <input type="checkbox"/> ZP3-10B <input type="checkbox"/> ZP3-13B <input type="checkbox"/> ZP3-16B <input type="checkbox"/>	P.50
ZP3B-Y1J3-B3		ZP3-015U <input type="checkbox"/> ZP3-02U <input type="checkbox"/> ZP3-035U <input type="checkbox"/>	P.51
ZP3B-Y1J6-B3		ZP3-015U <input type="checkbox"/> ZP3-02U <input type="checkbox"/> ZP3-035U <input type="checkbox"/>	P.51
ZP3B-Y1K3-B3		ZP3-015U <input type="checkbox"/> ZP3-02U <input type="checkbox"/> ZP3-035U <input type="checkbox"/>	P.51
ZP3B-Y1K6-B3		ZP3-015U <input type="checkbox"/> ZP3-02U <input type="checkbox"/> ZP3-035U <input type="checkbox"/>	P.51

Pad Unit

Vertical  
With Adapter:  
Vacuum Inlet

Vertical  
With Buffer:  
Vacuum Inlet

Lateral  
With Adapter:  
Vacuum Inlet

Lateral  
With Buffer:  
Vacuum Inlet

Construction

Adapter Applicable  
Pad List





Buffer Applicable  
Pad List

Mounting  
Adapter Part No.

Buffer Assembly  
Part No.

# Series ZP3

## Buffer Assembly Part No.

Buffer assembly part no.		Applicable pad part no.	Page	Buffer assembly part no.		Applicable pad part no.	Page
		Series ZP3				Series ZP3	
ZP3B-Y2AJ3-B5		ZP3-04UM <input type="checkbox"/>	P.51	ZP3B-Y2AJB15-B5		ZP3-04UM <input type="checkbox"/>	P.51
ZP3B-Y2AJ6-B5		ZP3-06UM <input type="checkbox"/>				ZP3-06UM <input type="checkbox"/>	
ZP3B-Y2AJ10-B5		ZP3-08UM <input type="checkbox"/>				ZP3-08UM <input type="checkbox"/>	
ZP3B-Y2AK3-B5		ZP3-04B <input type="checkbox"/>	P.51	ZP3B-Y2AK15-B5		ZP3-04B <input type="checkbox"/>	P.51
ZP3B-Y2AK6-B5		ZP3-06B <input type="checkbox"/>				ZP3-06B <input type="checkbox"/>	
ZP3B-Y2AK10-B5		ZP3-08B <input type="checkbox"/>				ZP3-08B <input type="checkbox"/>	
		ZP3-04UM <input type="checkbox"/>				ZP3-04UM <input type="checkbox"/>	
		ZP3-06UM <input type="checkbox"/>		ZP3B-Y2AK20-B5		ZP3-06UM <input type="checkbox"/>	P.51
		ZP3-08UM <input type="checkbox"/>				ZP3-08UM <input type="checkbox"/>	
		ZP3-04B <input type="checkbox"/>				ZP3-04B <input type="checkbox"/>	
		ZP3-06B <input type="checkbox"/>				ZP3-06B <input type="checkbox"/>	
		ZP3-08B <input type="checkbox"/>				ZP3-08B <input type="checkbox"/>	

**Buffer Assembly Part No.**

Buffer assembly part no.	Applicable pad part no. Series ZP3	Page
ZP3B-Y2BJ3-B5	ZP3-10UM <input type="checkbox"/> ZP3-13UM <input type="checkbox"/> ZP3-16UM <input type="checkbox"/> ZP3-10B <input type="checkbox"/> ZP3-13B <input type="checkbox"/> ZP3-16B <input type="checkbox"/>	P.52
ZP3B-Y2BJ6-B5	ZP3-10UM <input type="checkbox"/> ZP3-13UM <input type="checkbox"/> ZP3-16UM <input type="checkbox"/> ZP3-10B <input type="checkbox"/> ZP3-13B <input type="checkbox"/> ZP3-16B <input type="checkbox"/>	P.52
ZP3B-Y2BJ10-B5	ZP3-10UM <input type="checkbox"/> ZP3-13UM <input type="checkbox"/> ZP3-16UM <input type="checkbox"/> ZP3-10B <input type="checkbox"/> ZP3-13B <input type="checkbox"/> ZP3-16B <input type="checkbox"/>	P.52
ZP3B-Y2BK3-B5	ZP3-10UM <input type="checkbox"/> ZP3-13UM <input type="checkbox"/> ZP3-16UM <input type="checkbox"/> ZP3-10B <input type="checkbox"/> ZP3-13B <input type="checkbox"/> ZP3-16B <input type="checkbox"/>	P.52
ZP3B-Y2BK6-B5	ZP3-10UM <input type="checkbox"/> ZP3-13UM <input type="checkbox"/> ZP3-16UM <input type="checkbox"/> ZP3-10B <input type="checkbox"/> ZP3-13B <input type="checkbox"/> ZP3-16B <input type="checkbox"/>	P.52
ZP3B-Y2BK10-B5	ZP3-10UM <input type="checkbox"/> ZP3-13UM <input type="checkbox"/> ZP3-16UM <input type="checkbox"/> ZP3-10B <input type="checkbox"/> ZP3-13B <input type="checkbox"/> ZP3-16B <input type="checkbox"/>	P.52



Buffer assembly part no.	Applicable pad part no. Series ZP3	Page
ZP3B-Y2BJB15-B5	ZP3-10UM <input type="checkbox"/> ZP3-13UM <input type="checkbox"/> ZP3-16UM <input type="checkbox"/> ZP3-10B <input type="checkbox"/> ZP3-13B <input type="checkbox"/> ZP3-16B <input type="checkbox"/>	P.52
ZP3B-Y2BJB20-B5	ZP3-10UM <input type="checkbox"/> ZP3-13UM <input type="checkbox"/> ZP3-16UM <input type="checkbox"/> ZP3-10B <input type="checkbox"/> ZP3-13B <input type="checkbox"/> ZP3-16B <input type="checkbox"/>	P.52
ZP3B-Y2BK15-B5	ZP3-10UM <input type="checkbox"/> ZP3-13UM <input type="checkbox"/> ZP3-16UM <input type="checkbox"/> ZP3-10B <input type="checkbox"/> ZP3-13B <input type="checkbox"/> ZP3-16B <input type="checkbox"/>	P.52
ZP3B-Y2BK20-B5	ZP3-10UM <input type="checkbox"/> ZP3-13UM <input type="checkbox"/> ZP3-16UM <input type="checkbox"/> ZP3-10B <input type="checkbox"/> ZP3-13B <input type="checkbox"/> ZP3-16B <input type="checkbox"/>	P.52

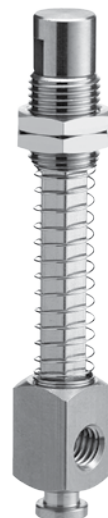

Vertical  
With Adapter:  
Vacuum Inlet

Vertical  
With Buffer:  
Vacuum Inlet

Lateral  
With Adapter:  
Vacuum Inlet

Lateral  
With Buffer:  
Vacuum Inlet

Construction

Adapter Applicable  
Pad List

Buffer Applicable  
Pad List

Mounting  
Adapter Part No.

Buffer Assembly  
Part No.

# Series ZP3

# Mounting Adapter Part No.

Vacuum Inlet Direction **Vertical**

Adapter part no.	<b>ZP3A-T1-A3</b> [Weight: 0.5 g]
Applicable pad part no.	
<b>ZP3-015U</b> <b>ZP3-02U</b> <b>ZP3-035U</b>	

Adapter part no.	<b>ZP3A-T2-B5</b> [Weight: 2.0 g]
Applicable pad part no.	
<b>ZP3-04UM</b> <b>ZP3-06UM</b> <b>ZP3-08UM</b> <b>ZP3-04B</b> <b>ZP3-06B</b> <b>ZP3-08B</b>	

Adapter part no.	<b>ZP3A-T1-B3</b> [Weight: 0.8 g]
Applicable pad part no.	
<b>ZP3-015U</b> <b>ZP3-02U</b> <b>ZP3-035U</b>	

Adapter part no.	<b>ZP3A-T2-A10-B5</b> [Weight: 10.7 g]
Applicable pad part no.	
<b>ZP3-04UM</b> <b>ZP3-06UM</b> <b>ZP3-08UM</b> <b>ZP3-04B</b> <b>ZP3-06B</b> <b>ZP3-08B</b>	

Adapter part no.	<b>ZP3A-T1-A6-B3</b> [Weight: 2.7 g]
Applicable pad part no.	
<b>ZP3-015U</b> <b>ZP3-02U</b> <b>ZP3-035U</b>	

Adapter part no.	<b>ZP3A-T2-A10-04</b> [Weight: 9.9 g]
Applicable pad part no.	
<b>ZP3-04UM</b> <b>ZP3-06UM</b> <b>ZP3-08UM</b> <b>ZP3-04B</b> <b>ZP3-06B</b> <b>ZP3-08B</b>	

Adapter part no.	<b>ZP3A-T2-A5</b> [Weight: 1.4 g]
Applicable pad part no.	
<b>ZP3-04UM</b> <b>ZP3-06UM</b> <b>ZP3-08UM</b> <b>ZP3-04B</b> <b>ZP3-06B</b> <b>ZP3-08B</b>	

Adapter part no.	<b>ZP3A-T3-A5</b> [Weight: 2.4 g]
Applicable pad part no.	
<b>ZP3-10UM</b> <b>ZP3-13UM</b> <b>ZP3-16UM</b> <b>ZP3-10B</b> <b>ZP3-13B</b> <b>ZP3-16B</b>	



Vacuum Inlet Direction **Vertical**

Adapter part no.	<b>ZP3A-T3-B5</b> [Weight: 5.1 g]
------------------	-----------------------------------

Applicable pad part no.
ZP3-10UM
ZP3-13UM
ZP3-16UM
ZP3-10B
ZP3-13B
ZP3-16B

Adapter part no.	<b>ZP3A-T3-A12-04</b> [Weight: 19.6 g]
------------------	--

Applicable pad part no.
ZP3-10UM
ZP3-13UM
ZP3-16UM
ZP3-10B
ZP3-13B
ZP3-16B

Adapter part no.	<b>ZP3A-T3-A12-B5</b> [Weight: 18.2 g]
------------------	--

Applicable pad part no.
ZP3-10UM
ZP3-13UM
ZP3-16UM
ZP3-10B
ZP3-13B
ZP3-16B

Adapter part no.	<b>ZP3A-T3-A12-06</b> [Weight: 17.5 g]
------------------	--

Applicable pad part no.
ZP3-10UM
ZP3-13UM
ZP3-16UM
ZP3-10B
ZP3-13B
ZP3-16B

Vacuum Inlet Direction **Lateral**

Adapter part no.	<b>ZP3A-Y1-B3</b> [Weight: 1.8 g]
------------------	-----------------------------------

Applicable pad part no.
ZP3-015U
ZP3-02U
ZP3-035U

Adapter part no.	<b>ZP3A-Y2-B5</b> [Weight: 6.7 g]
------------------	-----------------------------------

Applicable pad part no.
ZP3-04UM
ZP3-06UM
ZP3-08UM
ZP3-04B
ZP3-06B
ZP3-08B

Adapter part no.	<b>ZP3A-Y3-B5</b> [Weight: 7.1 g]
------------------	-----------------------------------

Applicable pad part no.
ZP3-10UM
ZP3-13UM
ZP3-16UM
ZP3-10B
ZP3-13B
ZP3-16B

Pad Unit

Vertical

With Adapter: Vacuum Inlet

Vertical

With Buffer: Vacuum Inlet

Lateral

With Adapter: Vacuum Inlet

Lateral

With Buffer: Vacuum Inlet

Construction

Adapter Applicable Pad List

Buffer Applicable Pad List

Mounting Adapter Part No.

Buffer Assembly Part No.



# Series ZP3

# Buffer Assembly Part No.

Vacuum Inlet Direction

**Vertical**

Buffer assembly part no.	Weight(g)
ZP3B-T1J3-B3	3.5
ZP3B-T1J6-B3	4.3
ZP3B-T1K3-B3	6.7
ZP3B-T1K6-B3	8.1

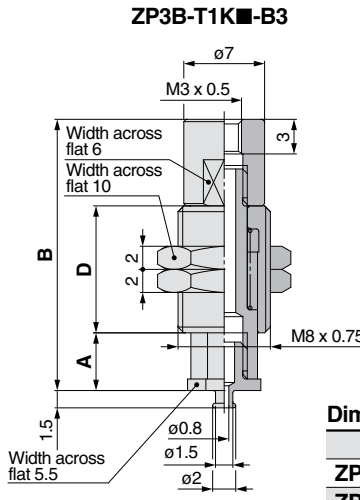
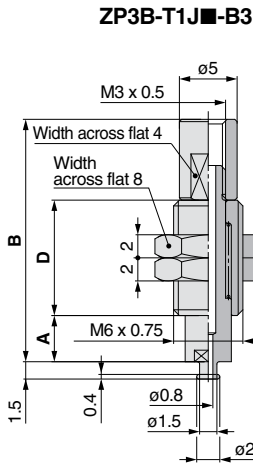

Applicable pad part no.
ZP3-015U
ZP3-02U
ZP3-035U

**Dimensions (per stroke)**

Model	A	B	D
ZP3B-T1J3-B3	4	21	10
ZP3B-T1J6-B3	7	28	14

**Dimensions (per stroke)**

Model	A	B	D
ZP3B-T1K3-B3	5	23.5	11
ZP3B-T1K6-B3	8	30	14.5

Buffer assembly part no.	Weight(g)
ZP3B-T2AJ3-B5	7.1
ZP3B-T2AJ6-B5	8.3
ZP3B-T2AJ10-B5	10.2
ZP3B-T2AK3-B5	7.0
ZP3B-T2AK6-B5	8.3
ZP3B-T2AK10-B5	10.2

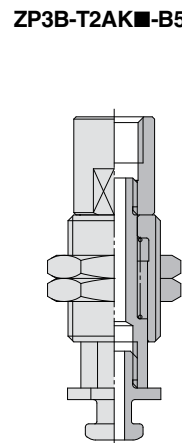
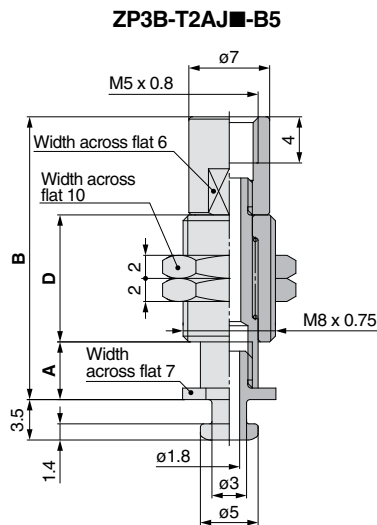

Applicable pad part no.
ZP3-04UM
ZP3-06UM
ZP3-08UM
ZP3-04B
ZP3-06B
ZP3-08B

**Dimensions (per stroke)**

Model	A	B	D
ZP3B-T2A☆3-B5	5	24.5	11
ZP3B-T2A☆6-B5	8	31	14.5
ZP3B-T2A☆10-B5	12	41	20.5

Note) The symbol "☆" indicates buffer type "J" or "K".

Buffer assembly part no.	Weight(g)
ZP3B-T2AJB15-B5	10.0
ZP3B-T2AJB20-B5	10.6
ZP3B-T2AK15-B5	12.0
ZP3B-T2AK20-B5	13.1

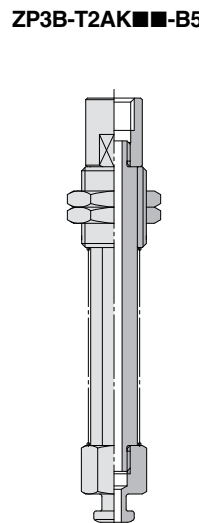
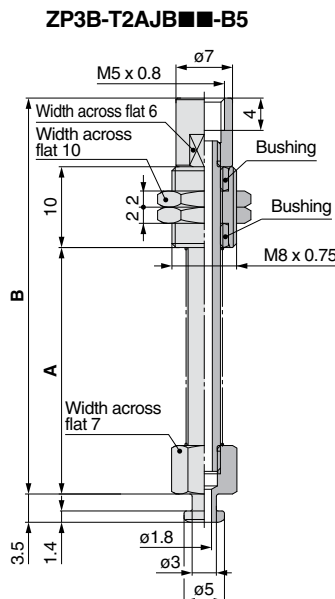

Applicable pad part no.
ZP3-04UM
ZP3-06UM
ZP3-08UM
ZP3-04B
ZP3-06B
ZP3-08B

**Dimensions (per stroke)**

Model	A	B
ZP3B-T2A☆15-B5	30.5	49
ZP3B-T2A☆20-B5	38	56.5

Note) The symbol "☆" indicates buffer type "JB" or "K".

\* Refer to the front matter 25 for nut tightening torque.

## Vacuum Inlet Direction **Vertical**

Buffer assembly part no.	Weight(g)
ZP3B-T2BJ3-B5	7.8
ZP3B-T2BJ6-B5	8.9
ZP3B-T2BJ10-B5	10.9
ZP3B-T2BK3-B5	7.7
ZP3B-T2BK6-B5	8.9
ZP3B-T2BK10-B5	10.9

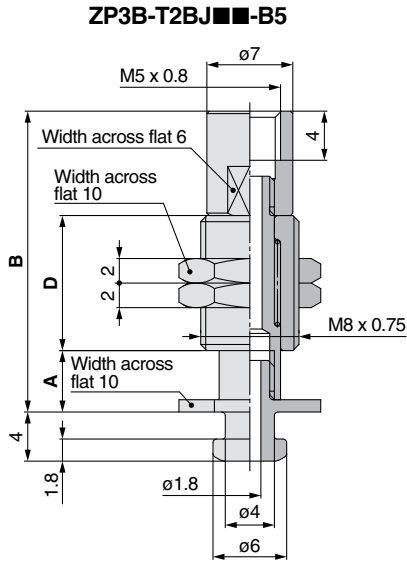

Applicable pad part no.

ZP3-10UM  
ZP3-13UM  
ZP3-16UM  
ZP3-10B  
ZP3-13B  
ZP3-16B

### Dimensions (per stroke)

Model	A	B	D
ZP3B-T2B☆3-B5	5	24.5	11
ZP3B-T2B☆6-B5	8	31	14.5
ZP3B-T2B☆10-B5	12	41	20.5

Note) The symbol "☆" indicates buffer type "J" or "K".

Buffer assembly part no.	Weight(g)
ZP3B-T2BJB15-B5	12.5
ZP3B-T2BJB20-B5	15.6
ZP3B-T2BK15-B5	14.5
ZP3B-T2BK20-B5	15.6

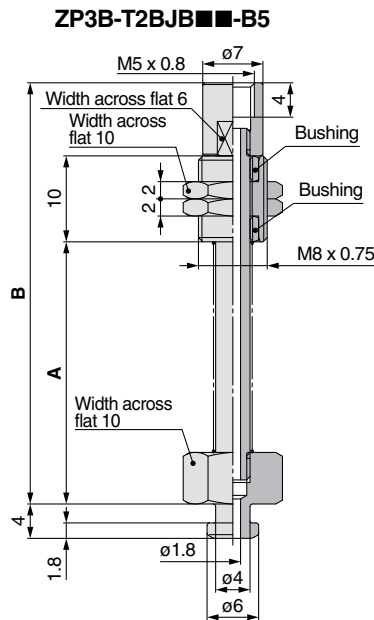

Applicable pad part no.

ZP3-10UM  
ZP3-13UM  
ZP3-16UM  
ZP3-10B  
ZP3-13B  
ZP3-16B

### Dimensions (per stroke)

Model	A	B
ZP3B-T2B☆15-B5	30.5	49
ZP3B-T2B☆20-B5	38	56.5

Note) The symbol "☆" indicates buffer type "JB" or "K".

Pad Unit

Vertical

With Adapter:  
Vacuum Inlet

Vertical

With Buffer:  
Vacuum Inlet

Lateral

With Adapter:  
Vacuum Inlet

Lateral

With Buffer:  
Vacuum Inlet

Construction

Adapter Applicable  
Pad List

Buffer Applicable  
Pad List

Mounting Adapter  
Part No.

Buffer Assembly  
Part No.

# Series ZP3

## Vacuum Inlet Direction **Lateral**

Buffer assembly part no.	Weight(g)
ZP3B-Y1J3-B3	7.6
ZP3B-Y1J6-B3	8.5
ZP3B-Y1K3-B3	10.9
ZP3B-Y1K6-B3	12.1

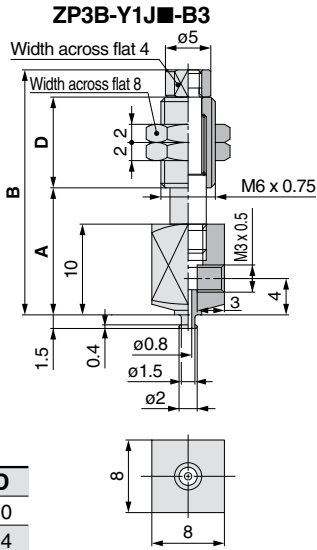

### Dimensions (per stroke)

Model	A	B	D
ZP3B-Y1J3-B3	14	27	10
ZP3B-Y1J6-B3	17	34	14

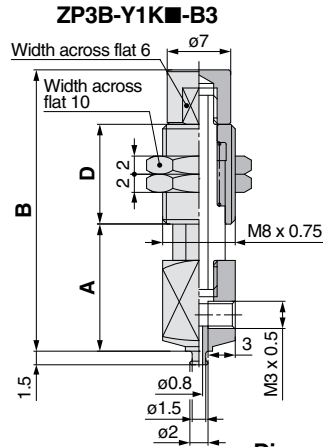

### Dimensions (per stroke)

Model	A	B	D
ZP3B-Y1K3-B3	14	31	11
ZP3B-Y1K6-B3	17	37.5	14.5

Applicable pad part no.

ZP3-015U  
ZP3-02U  
ZP3-035U

Buffer assembly part no.	Weight(g)
ZP3B-Y2AJ3-B5	12.5
ZP3B-Y2AJ6-B5	13.9
ZP3B-Y2AJ10-B5	16.3
ZP3B-Y2AK3-B5	11.9
ZP3B-Y2AK6-B5	13.1
ZP3B-Y2AK10-B5	15.1

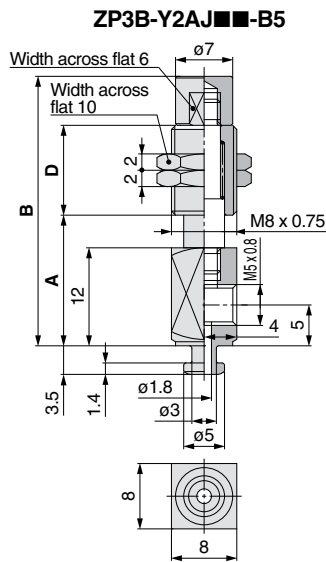

### ZP3B-Y2AK

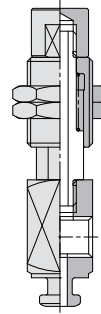

### Dimensions (per stroke)

Model	A	B	D
ZP3B-Y2A☆3-B5	16.5	34	11
ZP3B-Y2A☆6-B5	19	40	14.5
ZP3B-Y2A☆10-B5	23	50	20.5

Note) The symbol "☆" indicates buffer type "J" or "K".

Applicable pad part no.

ZP3-04UM  
ZP3-06UM  
ZP3-08UM  
ZP3-04B  
ZP3-06B  
ZP3-08B

Buffer assembly part no.	Weight(g)
ZP3B-Y2AJB15-B5	14.0
ZP3B-Y2AJB20-B5	14.8
ZP3B-Y2AK15-B5	15.2
ZP3B-Y2AK20-B5	16.3

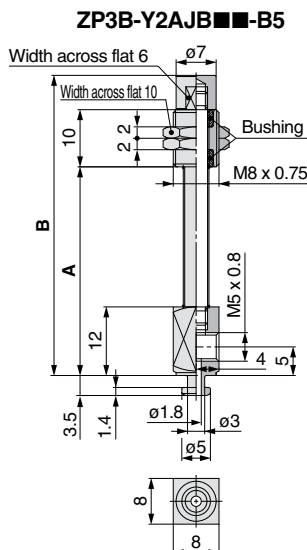

### ZP3B-Y2AK

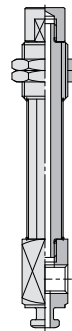

### Dimensions (per stroke)

Model	A	B
ZP3B-Y2A☆15-B5	36.5	53
ZP3B-Y2A☆20-B5	44	60.5

Note) The symbol "☆" indicates buffer type "JB" or "KB".

Applicable pad part no.

ZP3-04UM  
ZP3-06UM  
ZP3-08UM  
ZP3-04B  
ZP3-06B  
ZP3-08B

\* Refer to the front matter 25 for nut tightening torque.

## Vacuum Inlet Direction **Lateral**

Buffer assembly part no.	Weight(g)
ZP3B-Y2BJ3-B5	13.0
ZP3B-Y2BJ6-B5	14.3
ZP3B-Y2BJ10-B5	16.7
ZP3B-Y2BK3-B5	12.4
ZP3B-Y2BK6-B5	13.6
ZP3B-Y2BK10-B5	15.5

**ZP3B-Y2BJB■-B5**

**ZP3B-Y2BK■-B5**

Applicable pad part no.
ZP3-10UM
ZP3-13UM
ZP3-16UM
ZP3-10B
ZP3-13B
ZP3-16B

**Dimensions (per stroke)**

Model	A	B	D
ZP3B-Y2B☆3-B5	16.5	34	11
ZP3B-Y2B☆6-B5	19	40	14.5
ZP3B-Y2B☆10-B5	23	50	20.5

Note) The symbol "☆" indicates buffer type "J" or "K".

Buffer assembly part no.	Weight(g)
ZP3B-Y2BJB15-B5	14.4
ZP3B-Y2BJB20-B5	15.2
ZP3B-Y2BK15-B5	15.6
ZP3B-Y2BK20-B5	16.7

**ZP3B-Y2BJB■-B5**

**ZP3B-Y2BK■-B5**

Applicable pad part no.
ZP3-10UM
ZP3-13UM
ZP3-16UM
ZP3-10B
ZP3-13B
ZP3-16B

**Dimensions (per stroke)**

Model	A	B
ZP3B-Y2B☆15-B5	36.5	53
ZP3B-Y2B☆20-B5	44	60.5

Note) The symbol "☆" indicates buffer type "JB" or "K".

**Pad Unit**  
**Vertical**  
 With Adapter: Vacuum Inlet  
**Vertical**  
 With Buffer: Vacuum Inlet  
**Lateral**  
 With Adapter: Vacuum Inlet  
**Lateral**  
 With Buffer: Vacuum Inlet  
**Construction**  
**Adapter Applicable Pad List**  
**Buffer Applicable Pad List**  
**Mounting Adapter Part No.**  
**Buffer Assembly Part No.**



# Vacuum Equipment Precautions 1

Be sure to read this before handling.

## Design/Selection

### Warning

#### 1. Confirm the specifications.

Products represented in this catalog are designed only for use in compressed air systems (including vacuum). Do not operate at pressures or temperatures, etc., beyond the range of specifications, as this can cause damage or malfunction. (Refer to the specifications.) Please contact SMC when using a fluid other than compressed air (including vacuum). We do not guarantee against any damage if the product is used outside of the specification range.

#### 2. Safe designs should be developed, which account for the possibility of accidents resulting from a drop in vacuum pressure due to power failure or trouble with the air supply, etc.

If vacuum pressure drops and there is a loss of vacuum pad adsorption force, workpieces being carried may fall, causing human injury or damage to machinery. Sufficient safety measures should be implemented, such as drop prevention, to avoid any accidents.

#### 3. Follow vacuum specifications for vacuum switching valves and vacuum release valves.

If non-vacuum equipment is installed in a vacuum piping, vacuum leakage will occur. Therefore, select only equipment for vacuum specifications.

#### 4. Select an ejector which has a suitable suction flow rate.

<When there is vacuum leakage from the workpiece or the piping>  
If the ejector's suction flow rate is too low, the adsorption will be poor.  
<When piping is long or the diameter is large>  
The adsorption response time will delay due to the increased volume of the piping.  
Select an ejector with a suitable suction flow rate by referring to the technical data.

#### 5. If the suction flow rate is too high, setting of vacuum switch will become difficult.

Setting the vacuum switch when absorbing a small (few millimeter) workpiece will sometimes become difficult, if the selected ejector has a high suction rate and there is a small pressure difference when absorbing and releasing the workpiece.

#### 6. When two or more pads are piped to one ejector, if one pad releases its workpiece, the other pads will also release.

When one pad releases its workpiece, there is a drop in vacuum pressure which causes the other pad to release its workpiece as well.

#### 7. When separating the pad from the workpiece, break the vacuum and confirm that the pressure is atmospheric pressure.

Do not separate them forcibly while vacuum pressure exists between them. This may cause cracking, tearing, or distortion of the pad, or cause the pad to come off the adapter.

#### 8. Do not apply lateral load (force) such as rotation or sliding force of the workpiece to the adsorption surface of the pad during adsorption of the workpiece.

This may cause deformation, cracking, tearing, or distortion of the pad, or cause the pad to come off the adapter.

#### 9. Do not disassemble the product or make any modifications, including additional machining.

It may cause human injury and/or an accident. When disassembling or assembling the product for the purpose of replacing parts, etc., be certain to follow the operation manual or catalogs.

#### 10. Check valve

SMC can issue no guarantees regarding the maintenance of workpiece adsorption when using check valves. Take separate safety measures to prevent workpieces from dropping in the case of an electrical power outage, etc. Please consult with SMC when using check valves as a means of preventing interference caused by the exhaust from nearby ejectors.

### Caution

#### 1. Mounting the suction filter

Because the suction of vacuum equipment acts not only on workpieces but also on dust or water droplets in the surrounding atmosphere, steps must be taken to prevent their penetration into the equipment's interior. Even when using equipment equipped with filters, if there is a considerable amount of dust in the environment, use a separately ordered large-size filter as well.

If there is a possibility of water droplets being sucked in by the vacuum, use a drain separator for vacuum.

#### 2. The maximum vacuum pressure of the vacuum ejector is affected by the atmospheric pressure of the operating environment.

As atmospheric pressure changes based on altitude, climate, etc., the actual maximum vacuum pressure may not reach the value listed in the specifications.

#### 3. For information on related items, such as directional control equipment and drive equipment, refer to the caution sections in each respective catalog.

#### 4. Do not use the product in an environment that exposes it to vibration. If the product is used in such an environment, we can offer a lock nut type product to prevent it from loosening. Please contact SMC for model number.

## Mounting

### Warning

#### 1. Operation manual

Install the products and operate them only after reading the operation manual carefully and understanding its contents. Also, keep the manual available whenever necessary.

#### 2. Ensure sufficient space for maintenance activities.

When installing the products, allow access for maintenance.

#### 3. Tighten threads with the proper tightening torque.

When installing the products, follow the listed torque specifications.

#### 4. Do not obstruct the exhaust port of the ejector.

If the exhaust port is obstructed when mounted, a vacuum will not be generated. Also, do not obstruct the exhaust port with the goal of removing the workpiece. It may cause damage to the equipment.



# Vacuum Equipment Precautions 2

Be sure to read this before handling.

## Piping

### ⚠ Caution

**1. Refer to the Fittings and Tubing Precautions (Best Pneumatics No. 6) for handling onetouch fittings.**

**2. Preparation before piping**

Before piping is connected, it should be thoroughly blown out with air (flushing) or washed to remove chips, cutting oil and other debris from inside the pipe.

**3. Wrapping of pipe tape**

When screwing piping or fittings into ports, ensure that chips from the pipe threads or sealing material do not enter the piping. Also, if pipe tape is used, leave 1.5 to 2 thread ridges exposed at the end of the threads.

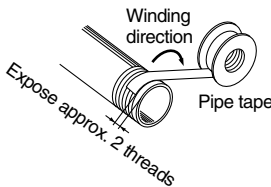

**4. Use piping with an adequate conductance.**

Select equipment and piping for the vacuum side which has an adequate conductance so that the ejector's maximum suction flow rate can be accommodated by the piping.

Also, make sure that there are no unnecessary restrictions or leaks, etc., along the course of the piping. Furthermore, design of the air supply should be performed while taking into consideration the ejector's maximum air consumption and the air consumption of other pneumatic circuits.

**5. Avoid disorganized piping.**

Piping which is direct and of the shortest possible length should be used for both the vacuum and supply sides.

Disorganized piping should be avoided. Unnecessary length increases the piping volume, and thus increases the response time.

**6. Use piping with a large conductance on the exhaust side of the ejector.**

If the exhaust piping is restrictive, there will be a decline in the ejector's performance.

**7. Be certain that there are no crushed areas in the piping due to damage or bending.**

## Air Supply

### ⚠ Warning

**1. Type of fluids**

Please consult with SMC when using the product in applications other than compressed air.

**2. When there is a large amount of drainage.**

Compressed air containing a large amount of drainage can cause malfunction of pneumatic equipment. An air dryer or water separator should be installed upstream from filters.

## Air Supply

### ⚠ Warning

**3. Drain flushing**

If condensation in the water separator and drain bowl is not emptied on a regular basis, the bowl will overflow and allow the condensation to enter the compressed air lines. It causes malfunction of pneumatic equipment.

If the drain bowl is difficult to check and remove, installation of a drain bowl with an auto drain option is recommended.

For compressed air quality, refer to SMC's Best Pneumatics catalog.

**4. Use clean air.**

Do not use compressed air that contains chemicals, synthetic oils including organic solvents, salt or corrosive gases, etc., as it can cause damage or malfunction.

## Operating Environment

### ⚠ Warning

- 1. Do not use in an atmosphere having corrosive gases, chemicals, sea water, water, water steam, or where there is direct contact with any of these.**
- 2. Do not use in a place subject to heavy vibration and/or shock.**
- 3. Do not use in an environment where flammable gas or explosive gas exists. Usage may cause a fire or explosion. The products do not have an explosion proof construction.**
- 4. The valve should not be exposed to prolonged sunlight. Use a protective cover.**
- 5. Remove any sources of excessive heat.**
- 6. In locations where there is contact with spatter from water, oil, solder, etc., take suitable protective measures.**
- 7. In cases where the vacuum unit is surrounded by other equipment, etc., or the unit is energized for an extended time, take measures to exhaust excess heat so that the temperature should be within specifications.**

### ⚠ Caution

- 1. Under certain conditions, the exhaust of the vacuum ejector may generate intermittent noises, and vacuum pressure may be uneven.**

Using the ejector under these conditions will not result in decreased performance, but if the intermittent noise becomes a nuisance, or there is an adverse effect on the operation of the vacuum pressure switch, try lowering or raising the supply pressure of the vacuum ejector to find a supply pressure level at which the intermittent noise ceases.



# Vacuum Equipment Precautions 3

Be sure to read this before handling.

## Maintenance

### Warning

#### 1. Perform maintenance inspection according to the procedures indicated in the operation manual.

If handled improperly, malfunction and damage of machinery or equipment may occur.

#### 2. Maintenance work

If handled improperly, compressed air can be dangerous. Assembly, handling, repair and element replacement of pneumatic systems should be performed by a knowledgeable and experienced person.

#### 3. Drain flushing

Remove drainage regularly from the water separator, air filters, vacuum drain separator, etc.

#### 4. Removal of equipment, and supply/exhaust of compressed air

When components are removed, first confirm that measures are in place to prevent workpieces from dropping, run-away equipment, etc. Then, cut off the supply pressure and electric power, and exhaust all compressed air from the system using the residual pressure release function.

When machinery is restarted after remounting or replacement, first confirm that measures are in place to prevent lurching of actuators, etc. Then, confirm that the equipment is operating normally.

#### 5. Clean suction filters and silencers on a regular basis.

The performance of an ejector will deteriorate due to clogged filters and silencers. High flow filters should be used, especially in dusty locations.



## Safety Instructions

These safety instructions are intended to prevent hazardous situations and/or equipment damage. These instructions indicate the level of potential hazard with the labels of “**Caution**,” “**Warning**” or “**Danger**.” They are all important notes for safety and must be followed in addition to International Standards (ISO/IEC)\*1), and other safety regulations.

 **Caution:** **Caution** indicates a hazard with a low level of risk which, if not avoided, could result in minor or moderate injury.

 **Warning:** **Warning** indicates a hazard with a medium level of risk which, if not avoided, could result in death or serious injury.

 **Danger:** **Danger** indicates a hazard with a high level of risk which, if not avoided, will result in death or serious injury.

\*1) ISO 4414: Pneumatic fluid power – General rules relating to systems.  
ISO 4413: Hydraulic fluid power – General rules relating to systems.  
IEC 60204-1: Safety of machinery – Electrical equipment of machines.  
(Part 1: General requirements)  
ISO 10218-1: Manipulating industrial robots - Safety.  
etc.

### Warning

**1. The compatibility of the product is the responsibility of the person who designs the equipment or decides its specifications.**

Since the product specified here is used under various operating conditions, its compatibility with specific equipment must be decided by the person who designs the equipment or decides its specifications based on necessary analysis and test results. The expected performance and safety assurance of the equipment will be the responsibility of the person who has determined its compatibility with the product. This person should also continuously review all specifications of the product referring to its latest catalog information, with a view to giving due consideration to any possibility of equipment failure when configuring the equipment.

**2. Only personnel with appropriate training should operate machinery and equipment.**

The product specified here may become unsafe if handled incorrectly. The assembly, operation and maintenance of machines or equipment including our products must be performed by an operator who is appropriately trained and experienced.

**3. Do not service or attempt to remove product and machinery/equipment until safety is confirmed.**

1. The inspection and maintenance of machinery/equipment should only be performed after measures to prevent falling or runaway of the driven objects have been confirmed.
2. When the product is to be removed, confirm that the safety measures as mentioned above are implemented and the power from any appropriate source is cut, and read and understand the specific product precautions of all relevant products carefully.
3. Before machinery/equipment is restarted, take measures to prevent unexpected operation and malfunction.

**4. Contact SMC beforehand and take special consideration of safety measures if the product is to be used in any of the following conditions.**

1. Conditions and environments outside of the given specifications, or use outdoors or in a place exposed to direct sunlight.
2. Installation on equipment in conjunction with atomic energy, railways, air navigation, space, shipping, vehicles, military, medical treatment, combustion and recreation, or equipment in contact with food and beverages, emergency stop circuits, clutch and brake circuits in press applications, safety equipment or other applications unsuitable for the standard specifications described in the product catalog.
3. An application which could have negative effects on people, property, or animals requiring special safety analysis.
4. Use in an interlock circuit, which requires the provision of double interlock for possible failure by using a mechanical protective function, and periodical checks to confirm proper operation.

### Caution

**1. The product is provided for use in manufacturing industries.**

The product herein described is basically provided for peaceful use in manufacturing industries.

If considering using the product in other industries, consult SMC beforehand and exchange specifications or a contract if necessary.

If anything is unclear, contact your nearest sales branch.

## Limited warranty and Disclaimer/ Compliance Requirements

The product used is subject to the following “Limited warranty and Disclaimer” and “Compliance Requirements”.

Read and accept them before using the product.

### Limited warranty and Disclaimer

**1. The warranty period of the product is 1 year in service or 1.5 years after the product is delivered.\*2)**

Also, the product may have specified durability, running distance or replacement parts. Please consult your nearest sales branch.

**2. For any failure or damage reported within the warranty period which is clearly our responsibility, a replacement product or necessary parts will be provided.**

This limited warranty applies only to our product independently, and not to any other damage incurred due to the failure of the product.

**3. Prior to using SMC products, please read and understand the warranty terms and disclaimers noted in the specified catalog for the particular products.**

\*2) **Vacuum pads are excluded from this 1 year warranty.**

A vacuum pad is a consumable part, so it is warranted for a year after it is delivered. Also, even within the warranty period, the wear of a product due to the use of the vacuum pad or failure due to the deterioration of rubber material are not covered by the limited warranty.

### Compliance Requirements

**1. The use of SMC products with production equipment for the manufacture of weapons of mass destruction (WMD) or any other weapon is strictly prohibited.**

**2. The exports of SMC products or technology from one country to another are governed by the relevant security laws and regulations of the countries involved in the transaction. Prior to the shipment of a SMC product to another country, assure that all local rules governing that export are known and followed.**

## Safety Instructions









Be sure to read “Handling Precautions for SMC Products” (M-E03-3) before using.



# Global Manufacturing, Distribution and Service Network

## Worldwide Subsidiaries

### North & South America

-  U.S.A. SMC Corporation of America
-  CANADA SMC Pneumatics (Canada) Ltd.
-  MEXICO SMC Corporation (México), S.A. de C.V.
-  BRAZIL SMC Pneumáticos do Brasil Ltda.
-  CHILE SMC Pneumatics (Chile) S.A.
-  COLOMBIA SMC Colombia Sucursal de SMC Chile S.A.
-  ARGENTINA SMC Argentina S.A.
-  BOLIVIA SMC Pneumatics Bolivia S.r.l.
-  VENEZUELA SMC Neumatica Venezuela S.A.
-  PERU (Distributor) IMPECO Automatización Industrial S.A.C.
-  ECUADOR (Distributor) ASSISTECH CIA. LTDA.













### Asia/Oceania

-  CHINA SMC (China) Co., Ltd.
-  CHINA SMC Pneumatics (Guangzhou) Ltd.
-  HONG KONG SMC Pneumatics (Hong Kong) Ltd.
-  TAIWAN SMC Pneumatics (Taiwan) Co., Ltd.
-  KOREA SMC Pneumatics Korea Co., Ltd.
-  SINGAPORE SMC Pneumatics (S.E.A.) Pte. Ltd.
-  MALAYSIA SMC Pneumatics (S.E.A.) Sdn. Bhd.
-  THAILAND SMC (Thailand) Ltd.
-  PHILIPPINES Shoketsu SMC Corporation
-  INDIA SMC Pneumatics (India) Pvt. Ltd.
-  ISRAEL (Distributor) Baccara Geva A.C.S. Ltd.
-  INDONESIA (Distributor) PT. Sinar Mutiara Cemerlang
-  VIETNAM (Distributor) Dy Dan Trading Co., Ltd.
-  PAKISTAN (Distributor) Jubilee Corporation

### Asia/Oceania

-  SRI LANKA (Distributor) Electro-Serv (Pvt.) Ltd.
-  IRAN (Distributor) Abzarchian Co. Ltd.
-  U.A.E. (Distributor) Machinery People Trading Co. L.L.C.
-  KUWAIT (Distributor) Esco Kuwait Equip & Petroleum App. Est.
-  SAUDI ARABIA (Distributor) Assaggaff Trading Est.
-  BAHRAIN (Distributor) Mohammed Jalal & Sons W.L.L. Technical & Automotive Services
-  SYRIA (Distributor) Miak Corporation
-  JORDAN (Distributor) Atafawok Trading Est.
-  BANGLADESH (Distributor) Chemie International
-  AUSTRALIA SMC Pneumatics (Australia) Pty. Ltd.
-  NEW ZEALAND SMC Pneumatics (N.Z.) Ltd.
-  JAPAN SMC Corporation

### Europe/Africa

-  GERMANY SMC Pneumatik GmbH
-  SWITZERLAND SMC Pneumatik AG
-  U.K. SMC Pneumatics (U.K.) Ltd.
-  FRANCE SMC Pneumatique SA
-  SPAIN / PORTUGAL SMC España S.A.
-  ITALY SMC Italia S.p.A.
-  GREECE SMC HELLAS E.P.E
-  IRELAND SMC Pneumatics (Ireland) Ltd.
-  NETHERLANDS (Associated company) SMC Pneumatics BV
-  BELGIUM (Associated company) SMC Pneumatics N.V./S.A.
-  DENMARK SMC Pneumatik A/S
-  AUSTRIA SMC Pneumatik GmbH (Austria)

### Europe/Africa

-  CZECH REPUBLIC SMC Industrial Automation CZ s.r.o.
-  HUNGARY SMC Hungary Ipari Automatizálási Kft.
-  POLAND SMC Industrial Automation Polska Sp. z o.o.
-  SLOVAKIA SMC Priemyselna Automatizacia Spol s.r.o.
-  SLOVENIA SMC Industrijska Avtomatika d.o.o.
-  BULGARIA SMC Industrial Automation Bulgaria EOOD
-  CROATIA SMC Industrijska Avtomatika d.o.o.
-  BOSNIA AND HERZEGOVINA (Distributor) A.M. Pneumatik d.o.o.
-  SERBIA (Distributor) Best Pneumatics d.o.o.
-  UKRAINE (Distributor) PNEUMOTEC Corp.
-  FINLAND SMC Pneumatics Finland Oy
-  NORWAY SMC Pneumatics Norway AS
-  SWEDEN SMC Pneumatics Sweden AB
-  ESTONIA SMC Pneumatics Estonia Oü
-  LATVIA SMC Pneumatics Latvia SIA
-  LITHUANIA (LIETUVA) UAB "SMC Pneumatics"
-  ROMANIA SMC Romania S.r.l.
-  RUSSIA SMC Pneumatik LLC.
-  KAZAKHSTAN SMC Kazakhstan, LLC.
-  TURKEY (Distributor) Entek Pnömatik Sanayi ve Ticaret Şirketi
-  MOROCCO (Distributor) Soraflex
-  TUNISIA (Distributor) Byms
-  EGYPT (Distributor) Saadani Trading & Industrial Services
-  NIGERIA (Distributor) Faraday Engineering Company Ltd.
-  SOUTH AFRICA (Distributor) Hyflo Southern Africa (Pty.) Ltd.

## U.S. & Canadian Sales Offices

### WEST

- Austin
- Dallas
- Los Angeles
- Phoenix
- Portland
- San Francisco
- Vancouver



### EAST

- Atlanta
- Birmingham
- Boston
- Charlotte
- Nashville
- New Jersey
- Richmond
- Rochester
- Tampa
- Montreal

### CENTRAL

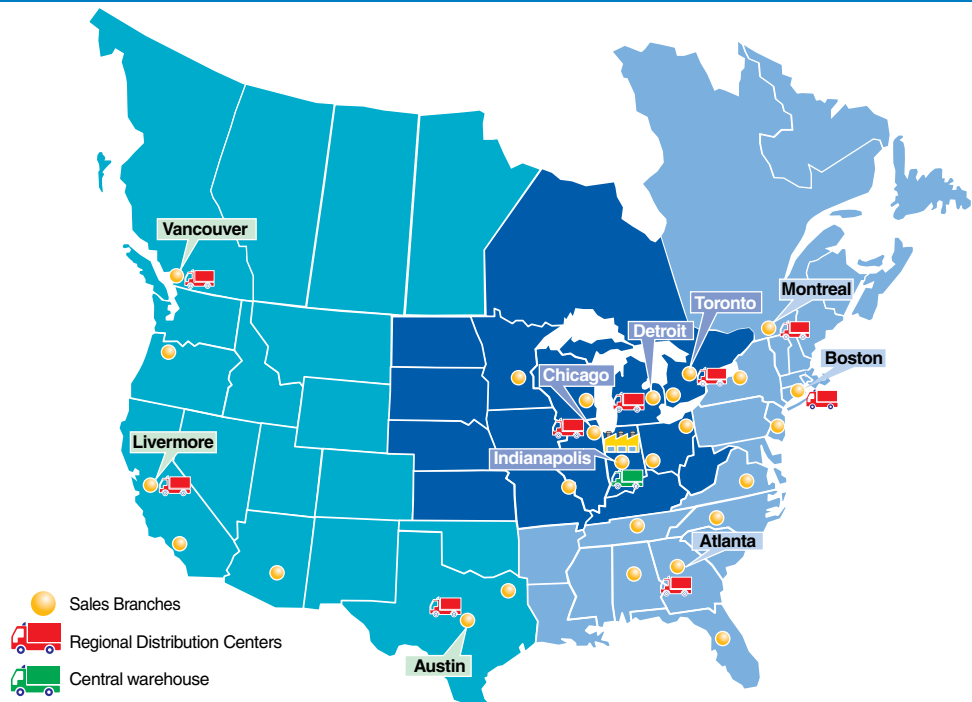
- Chicago
- Cincinnati
- Cleveland
- Detroit
- Indianapolis
- Milwaukee
- Minneapolis
- St. Louis
- Toronto
- Windsor



-  Sales Branches
-  Regional Distribution Centers
-  Central warehouse

### SMC Corporation of America

10100 SMC Blvd., Noblesville, IN 46060

[www.smcusa.com](http://www.smcusa.com)

### SMC Pneumatics (Canada) Ltd.

[www.smcpcanada.ca](http://www.smcpcanada.ca)

**(800) SMC.SMC1 (762-7621)**

**e-mail: [sales@smcusa.com](mailto:sales@smcusa.com)**

**For International inquiries: [www.smcworld.com](http://www.smcworld.com)**

