

Construction

Series ZPT

Series ZPX

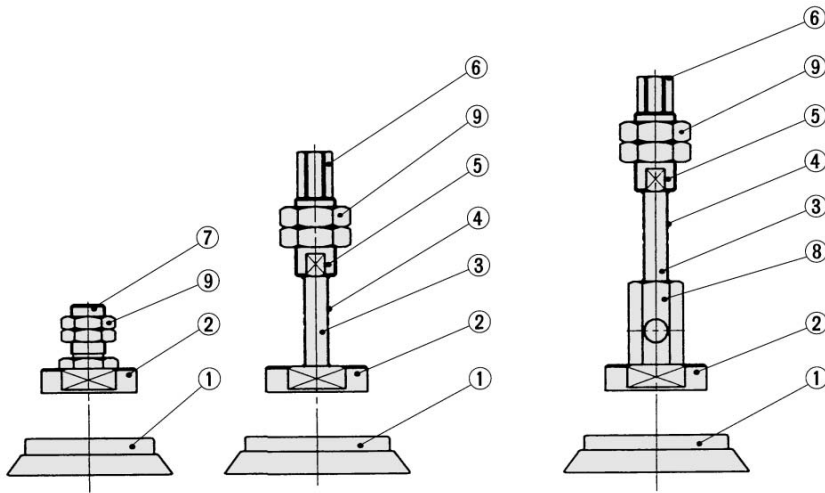

Component Parts

No.	Description	Material	Surface treatment
①	Pad	NBR, Silicone rubber, Urethane rubber, Fluoro rubber, EPR	—
②	Adapter plate	Aluminum	—
③	Piston rod	Carbon steel	Hard chrome plated
④	Spring	Stainless steel	—
⑤	Buffer body	Aluminum	—
⑥	Buffer adaptor	Brass	Electroless nickel plated
⑦	Adaptor A	Brass	Electroless nickel plated
⑧	X type adaptor	Brass	Electroless nickel plated
⑨	Mounting nut	Rolled steel	Black zinc chromated

Replacement Parts/Pad Unit

How to Order Pad Unit

ZP 40 H N

Pad dia. (mm) | Material

Pad dia. (mm)	Material
40	NBR
50	Silicon rubber
63	Urethane rubber
80	Fluoro rubber
100	EPR
125	EPR

Pad type: H Heavy duty

Pad Unit Weight

(NBR)

Model	Weight (g)
ZP40HN	15
ZP50HN	27
ZP63HN	57
ZP80HN	86
ZP100HN	160
ZP125HN	224

Add NBR weight to the table on the right for other materials.

Pad dia.	Silicon rubber	Urethane rubber	Fluoro rubber	EPR
ø40	-1	0	5	-1
ø50	-1	0	8	0
ø63	-2	0	16	0
ø80	-3	1	27	-1
ø100	-5	1	53	-1
ø125	-8	3	84	0

Dimensions

ZP₅₀⁴⁰H□

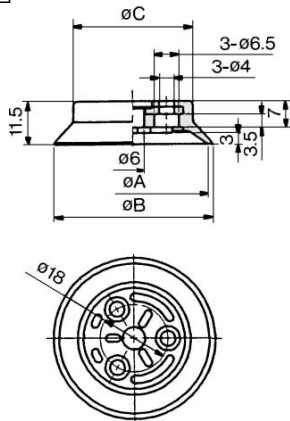

Model	øA	øB	øC
ZP40H□	40	42	32
ZP50H□	50	52	42

ZP₈₀⁶³H□

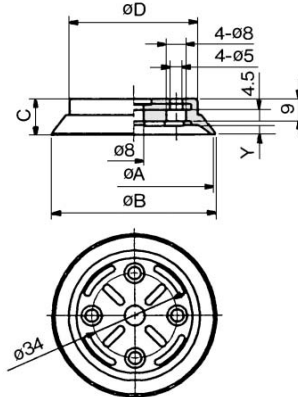

Model	øA	øB	C	D	Y
ZP63H□	63	65	14.5	50	3.5
ZP80H□	80	82	16.5	61	4.5

ZP₁₂₅¹⁰⁰H□

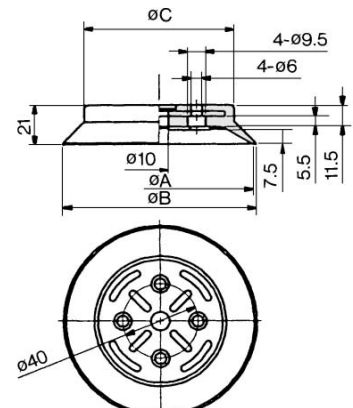

Model	øA	øB	øC
ZP100H□	100	103	80
ZP125H□	125	128	104