



SMC'S SOLUTIONS FOR FOOD  
SAFETY AND COMPLIANCE

**Add food  
safety to  
your recipe**

# Ensuring food safety and compliance

Ensuring compliance to the latest food safety legalisation / benchmarks is vital to the success of any food manufacturing business. With an increasing focus on food safety and hygienic design food manufacturing site auditors are paying close attention to these aspects.

Responding to this need, SMC has developed a range of products known as the **HF1, HF2 and HF3 series** which can help food manufacturers and OEMs satisfy the requirement to **meet their mandatory HACCP** (Hazard Awareness Critical Control Point) requirements for food safety.

# HF Series



# Product categories

## HF1

**When used, lubricants and rust proof agents for food machinery are used**

### HF1 Series

No lubricants or rust proof agents are used on the fluid contact parts.

### HF1A Series

No lubricants or rust proof agents are used on the external parts.

### HF1B Series

No lubricants or rust proof agents are used on the external parts or fluid contact parts.

## HF2

**When used, lubricants and rust proof agents for food machinery are used. In addition, U.S. FDA compliant materials are used**

### HF2 Series

No lubricants or rust proof agents are used on the fluid contact parts.

### HF2A Series

No lubricants or rust proof agents are used on the external parts.

### HF2B Series

No lubricants or rust proof agents are used on the external parts or fluid contact parts.

## HF3

**Certified by a third-party organisation**

### HF3 Series

Products certified by a third-party organisation.<sup>1)</sup>

1) Refer to each product catalogue for certification standards.

### HF3A Series

Uses materials that comply with food contact surface laws and regulations and does not use lubricants or rust proof agents.

# Food application

Find our products suitable for the requirements of diverse food manufacturing processes:

**Transfer**

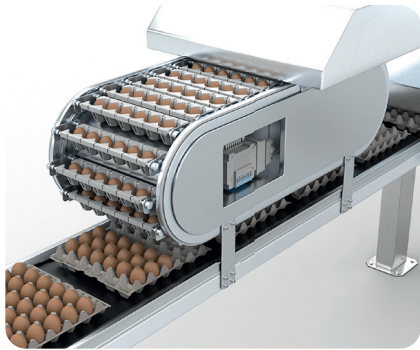

**Box making**

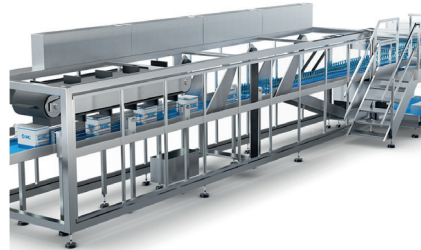

**Stirring and mixing**



**Filling**



**Cleaning**



**Sorting**



**Packaging**

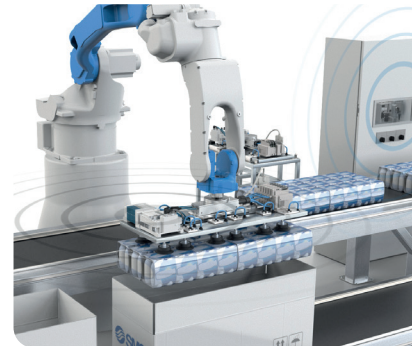

**Drying and cooling**



# HF1

## When used, lubricants and rust proof agents for food machinery are used

### HF1 Series

No lubricants or rust proof agents are used on the fluid contact parts.

#### Combination units



Air combination units  
HF1-AC-D-X7000 Series

#### Pressure regulators



Precision regulator  
HF1-IR1000/2000/3000-A

Electro-pneumatic regulator  
HF1-ITV2000/3000 Series



## Directional control valves

5-port solenoid valve plug-in type  
HF1-SY3000/5000/7000 Series

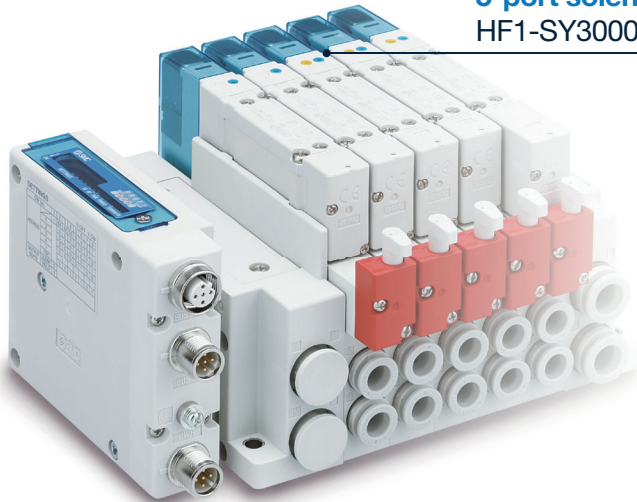

• 5-port solenoid valve body  
ported/single unit  
HF1-SY3000/5000/7000 Series

3-port solenoid valve  
HF1-VP300/500/700 Series

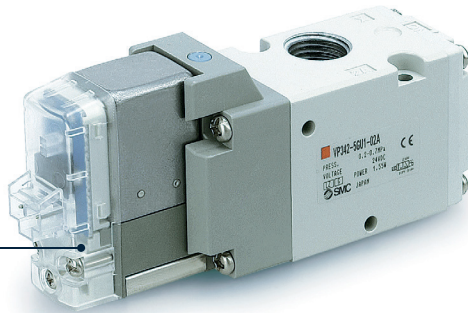

## Vacuum equipment

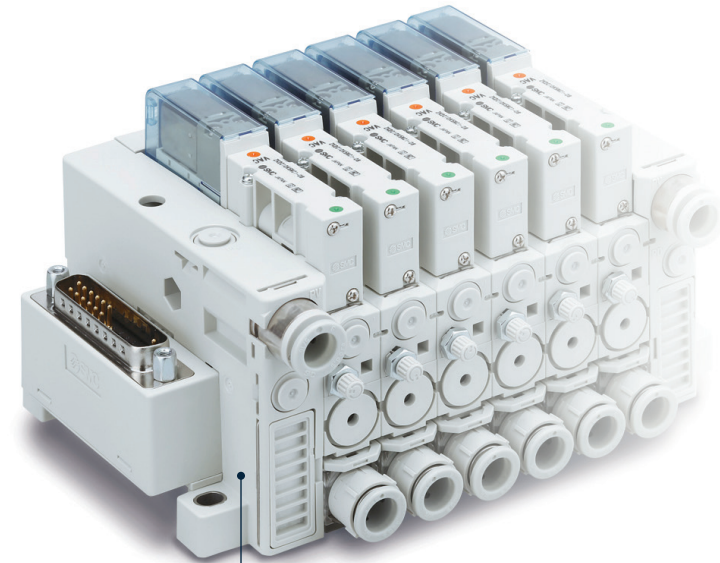

Vacuum unit  
HF1-ZK2□A Series

# HF1A Series

No lubricants or rust proof agents are used on the external parts.

## Electric actuators

- **High rigidity and high precision slider type**  
HF1A-LEKFS Series
- **Rod type**  
HF1A-LEY Series
- **Guide rod type**  
HF1A-LEYG Series

**Slider type**  
HF1A-LEFS Series



## Actuators



**Compact guide cylinder**  
HF1A-MGP Series

### Linear actuators

- **Air cylinder**  
HF1A-CJ2 Series
- **Air cylinder**  
HF1A-CM2 Series
- **Air cylinder**  
HF1A-CG1 Series
- **Free mount cylinder**  
HF1A-CU Series
- **Compact cylinder/Compact type**  
HF1A-CQS Series
- **Compact cylinder**  
HF1A-CQ2 Series
- **Compact cylinder with end lock**  
HF1A-CBQ2 Series

### Guided actuators

- **Dual rod cylinder/Compact type**  
HF1A-CXSJ Series
- **Dual rod cylinder**  
HF1A-CXS2 Series

### ISO cylinders

- **ISO cylinder**  
HF1A-C96 Series
- **ISO cylinder**  
HF1A-CP96 Series

# HF1B Series

No lubricants or rust proof agents are used on the external parts or fluid contact parts.

## Pressure regulators

- **Regulator**  
HF1B-AR-D Series



**Filter regulator**  
HF1B-AW-D Series

## Filters

- **Filter**  
HF1B-AF-D Series
- **Mist separator**  
HF1B-AFM-D Series
- **Micro mist separator**  
HF1B-AFD-D Series

## ISO 8573 compliant

- **Filter**  
HF1B-AFF-D Series
- **Micro mist separator**  
HF1B-AMD-D Series
- **Activated carbon filter**  
HF1B-AMK-D Series

**Mist separator**  
HF1B-AM-D Series



## Pressure relief 3-port valve

- **OSHA standard compliant, pressure relief 3-port valve**  
HF1B-VHS-D Series



## Speed controllers

Speed controller with one-touch fitting (Throttle valve)  
HF1B-AS-F(X214) Series



## Sensors & Switches

Pressure switch, reed switch type  
HF1B-IS10



## Process valves

2-port solenoid valve  
HF1B-JSX/JSXD Series



- Pulse valve  
HF1B-JSXF/JSXFA Series
- Modular mounting type 2-port solenoid valve  
HF1B-JSXM Series
- Mechanical valve  
HF1B-VM Series

## Vacuum equipment

- Vacuum ejector  
HF1B-ZH Series
- In-line type vacuum ejector  
HF1B-ZU□A Series



Multistage ejector  
HF1B-ZL1/3/6 Series

# HF1 compatible

The specifications are the same as those of the products from each series without the “HF-” part number prefix.

## Pressure regulators



Electro-pneumatic regulator  
ITV1000 Series

## Sensors & Switches

- 3-screen display high-precision digital pressure switch  
ZSE20(F)/ISE20-X2 Series
- 3-screen display high-precision digital pressure switch, grease-free  
ISE70/71-X2 Series
- Digital pressure switch, grease-free  
ISE35-X528 Series

3-screen display high-precision  
digital pressure switch  
ZSE20C(F)/ISE20C(H) Series



## Pressure gauges

- Pressure gauge for clean regulator  
G46-SRA, B Series

- Oil-free/external parts  
copper-free pressure gauge  
G46E Series



## Filters

- Clean air filter  
SFD Series

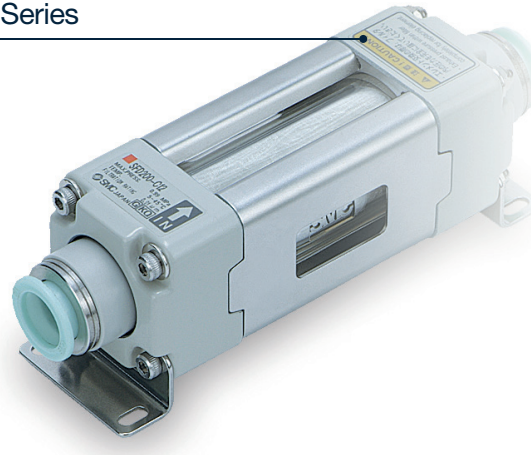

## HF1A compatible

## Pneumatic actuators

- Hygienic design cylinder  
HY□ Series

- Stainless steel cylinder  
CJ5-S/CG5-S/CG5W-S  
Series



## Floating joints

- Floating joint /  
stainless steel type  
JS Series



# HF1B compatible

## Tubing

- Nylon standard tubing, standard T/TIA Series
- Soft nylon general use tubing TS/TISA Series
- Polyurethane standard tubing TU/TIUB Series
- Soft polyurethane tubing TUS Series
- Polyurethane standard tubing, hard polyurethane TUH Series
- Wear resistant tubing, multi-core flat TUZ/TIUZB Series
- Polyurethane coil tubing, standard TCU Series
- Polyurethane general use tubing, multi-core flat TFU Series



## Speed controller

Stainless steel speed controller  
ASG Series



## Fitting

- Insert fittings KF Series
- Self-align fittings H/DL/L/LL Series
- 316 stainless steel, one-touch fittings KQG2 Series
- 316 stainless steel, insert fittings KFG2 Series
- Clean one-touch fittings KP Series
- S couplers Stainless Steel type KKA Series

Miniature fittings  
M Series

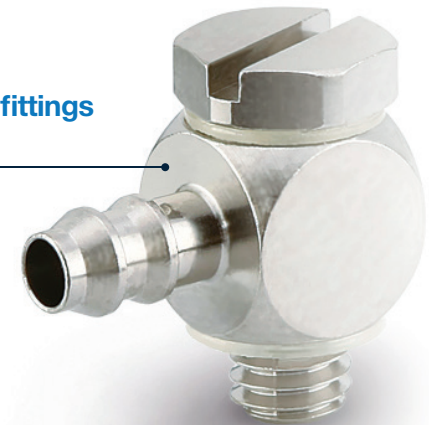

## Directional control valves

Clean design manifold valve  
lead wire type  
JSY5000-H Series

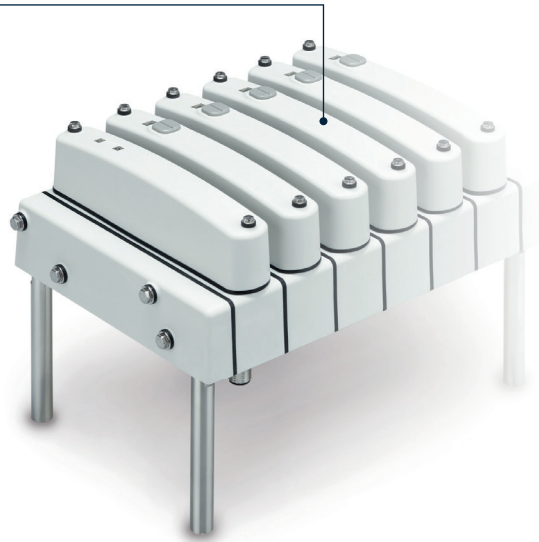

## Membrane air dryers

• Membrane air dryer  
IDG Series



Membrane air  
dryer  
IDG-D Series

## Nitrogen generator



Membrane nitrogen generator  
NMG Series

## Pressure regulators

Clean regulator  
SRH3000/4000 Series



## Pressure gauges

- Pressure gauge for general purpose (O.D. 42 mm)  
G46 Series
- Pressure gauge for general purpose, oil free (O.D. 37 mm)  
G36-X4 Series

Pressure gauge for general purpose (O.D. 37 mm)  
G36 Series



## Process valves



2-port high speed valve  
SX10 Series

## Sensors & Switches

- 2-colour display digital flow switch  
PF2M7 Series
- 2-colour display digital flow switch  
PFMB7 Series
- Flow sensor  
PFMV5 Series
- Flow controller for air  
PFCQ Series

Flow controller for air  
PFCQ Series



# HF2

**When used, lubricants and rust proof agents for food machinery are used. In addition, U.S. FDA compliant materials are used**

## HF2 Series

No lubricants or rust proof agents are used on the fluid contact parts.

### Combination units

Antibacterial air combination unit  
HF2-BAC Series



## HF2A Series

No lubricants or rust proof agents are used on the external parts.

### Actuator

· Stainless steel cylinder  
HF2A-CG5 Series

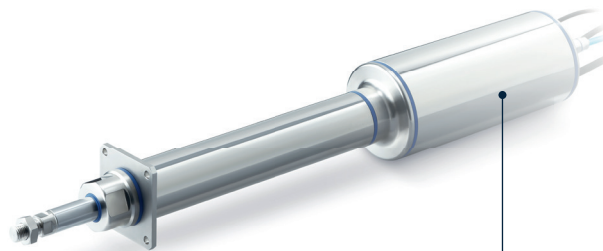

Rod type dust-tight/water-jet-proof  
(IP69K equivalent)  
HF2A-LEY Series

### Speed controllers

Speed controllers, stainless steel,  
simple handle, metal body, water  
resistant, elbow  
HF2A-ASG-V Series



# HF2B Series

No lubricants or rust proof agents are used on the external parts or fluid contact parts.

## Filters

**Bacteria removal filter**  
HF2B-SFDA Series



- **Antibacterial filter, 5 µm**  
HF2B-BFA Series
- **Antibacterial filter, 0.1 µm**  
HF2B-BFB Series
- **Bacteria removal filter**  
HF2B-BFD Series
- **Odour removal filter**  
HF2B-BFC Series

## Speed controllers

**Stainless steel throttle valve with one-touch fittings, in-line type, food compatible**  
HF2B-ASG-TV Series



# HF2A compatible

## Directional control valves

**Clean design manifold valve lead wire type**  
JSY5000-H Series

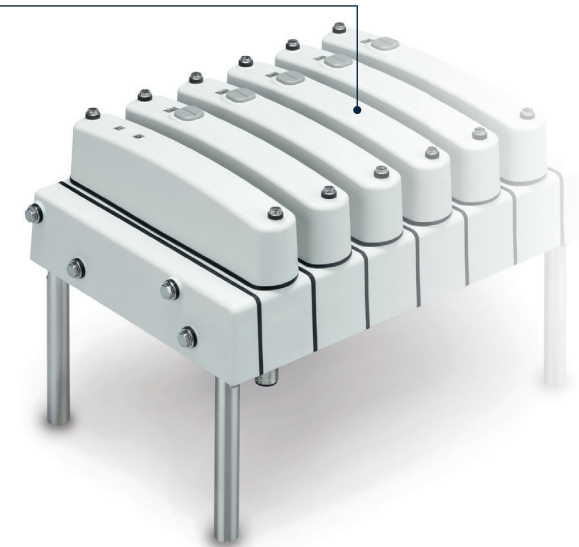

# HF2B compatible

## Fittings



### FDA compliant

- **Insert fitting, clean design**  
KFG2H-C Series
- **One-touch fitting, 316 stainless steel**  
KQG2-F Series
- **One-touch fitting, metal**  
KQB2-F Series
- **Insert fitting, 316 stainless steel**  
KFG2-F Series



**EHEDG compliant, FDA compliant  
male connector insert fitting**  
KFG2H-E Series

## Tubing

- **Clean and chemical resistant tubing, polyurethane, FDA compliant**  
TU-X214 Series
- **Chemical and heat resistant FEP tubing**  
TPH Series
- **Soft polyolefin tubing**  
TPS Series
- **Fluoropolymer tubing**  
TL/TIL Series
- **Fluoropolymer tubing (PFA)**  
TLM/TILM Series
- **Soft fluoropolymer tubing (modified PTFE)**  
TD/TID Series
- **Polyethylene tubing, FDA compliant**  
TX/TIX Series

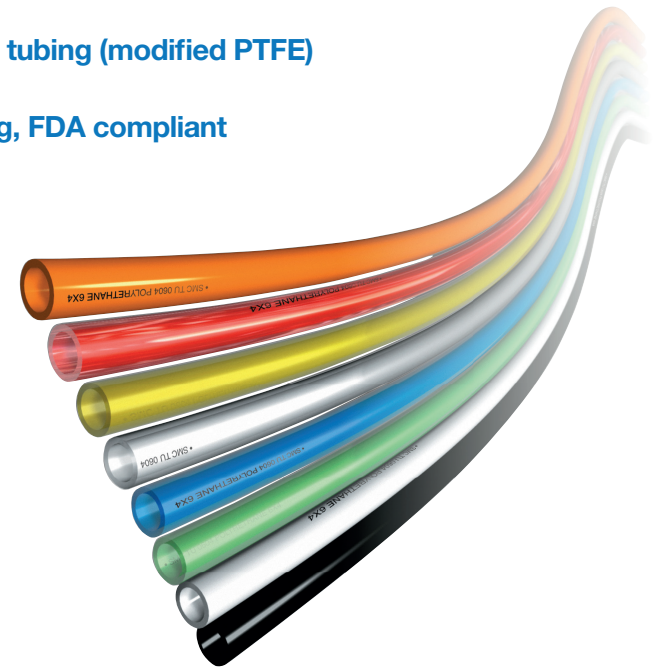

# HF3

## Certified by a third-party organisation

### HF3 Series

Products certified by a third-party organisation.<sup>1)</sup>

1) Refer to each product catalogue for certification standards.

#### Process valves

2-port solenoid valve  
HF3-JSX Series



### HF3A

Uses materials that comply with food contact surface laws and regulations and does not use lubricants or rust proof agents.

#### Vacuum pads

Suction cup, compatible with metal detectors  
HF3A-ZP3F Series



### HF3A compatible

#### Vacuum pads

Bernoulli gripper with coanda grip –  
ZNC-C Series



- Bernoulli gripper  
ZNC Series
- Suction cup, compatible with metal detectors, oval shape  
ZP3F-WJT Series

# SMC Business Continuity Plan

## Sustainable growth also means ensuring uninterrupted operations

We are committed to ensuring that SMC is prepared for any emergency and that our business activities will not stop in the event of such circumstances. SMC aims to fulfil our product supply responsibilities and maintain our customers' trust by contributing to both sustainable growth and the expansion of technological innovations.

SMC, as a comprehensive manufacturer of automatic control equipment that supports automation, is able to promptly provide products that meet our customers' needs anywhere in the world.

## Production BCP

### Ensure customer order fulfilment

Reliable delivery for you thanks to our 9 global logistic centres and 38 production sites worldwide. Moreover, flexibility to rapidly respond to any sudden change in the manufacturing environment.

## Finance BCP

### Safe & Solid financial base

In the event of an emergency, SMC can provide a safe and solid financial base (with cash, deposits, and equity capital) that will sufficiently cover the working capital and funds needed to rebuild buildings and the equipment required for business continuity. This is done to provide peace of mind to our customers and workers alike.

## Information security BCP

### Vital data kept safe

Strengthen information security for protection against computer viruses and cyberattacks, plus the installation of data centres to establish a disaster recovery system. Your information is safe with us.

## Engineering BCP

### Consistent technical support

2,000 engineers at our 5 technical centres around the globe.

## Sales BCP

### Consistent sales support

7,000 sales engineers worldwide ready to recommend the best solution for you. Over 80 global locations to make sure that wherever you are, we are there too.



**SMC Corporation**

1-5-5, Kyobashi,  
Chuo-ku, Tokyo  
104-0031, Japan  
Telephone: 03-6628-3000  
<https://www.smcworld.com>

**[www.smcworld.com](https://www.smcworld.com)**

Release EQ  
FOOD-B GLOBAL

SPECIFICATIONS ARE SUBJECT TO CHANGE WITHOUT PRIOR NOTICE AND ANY OBLIGATION ON THE PART OF THE MANUFACTURER