

Capable of air cylinder multipoint positioning and control

Air Servo Cylinder

IN-777

■ Repeatability for the stopping position: ± 0.5 mm

■ Servo valve and controller integrated cylinder

Built-in position sensor

The servo valve controls the flow rate on the cylinder head side and the rod side.

Self diagnosis function

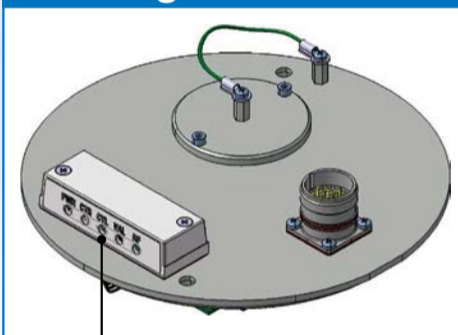

PWR : Power supply
CTR : Controller
CYL : Position sensor
VAL : Valve
RF : Rod friction

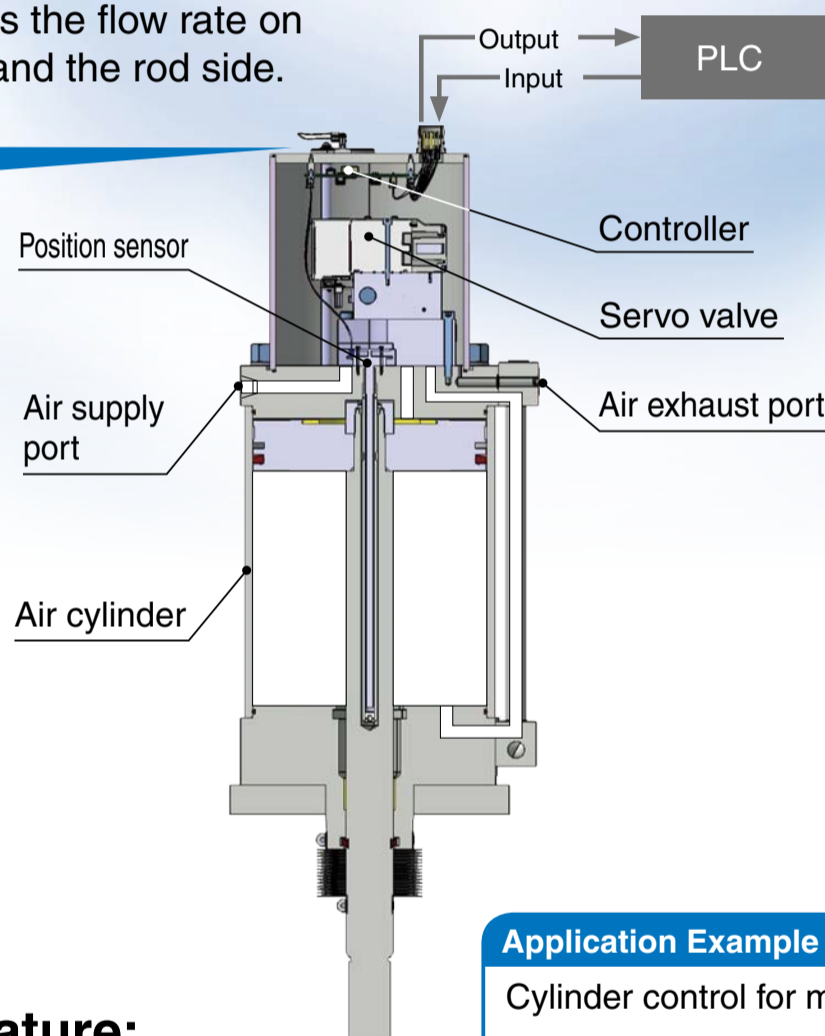

■ IP67

■ Ambient temperature:

-20°C to 60°C (No freezing)

■ Applicable to cylinders with diameters of $\varnothing 125$ to $\varnothing 400$

■ Input signal: 4 to 20 mA

■ With stroke position signal output function (4 to 20 mA)

■ HART transmission

■ With auto calibration function

■ Supports the fail safe function

Application Example

Cylinder control for maintaining a liquid level position

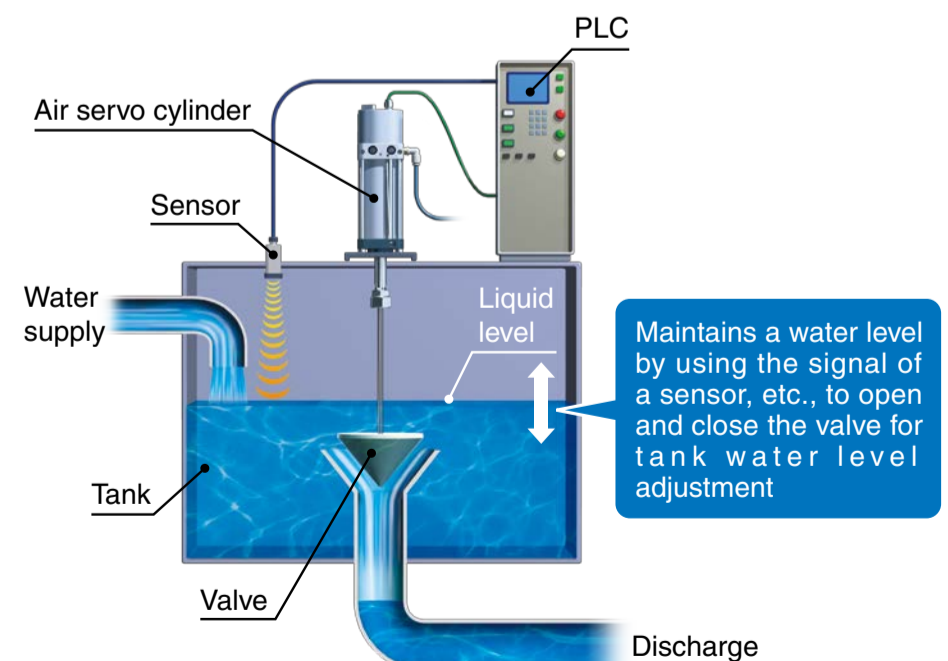

Caution

The application described here is for reference only and performance is not guaranteed. For actual usage in various other applications, please conduct thorough evaluation and validation testing in order to determine the feasibility under your actual usage conditions. Furthermore, please contact your local SMC sales representative for individual pricing and delivery verification.