



Operation Manual

PRODUCT NAME

Air Combination

MODEL / Series / Product Number

AC20(A)-(F,N)01~(F,N)02(C,E,E1,E2,E3,E4,G,M)-(1,2,3,6,C,J,N,R,Z,ZA)-D
AC20B,C,D -(F,N)01~(F,N)02(C,E,E1,E2,E3,E4,G,M)-(1,2,6,C,J,N,R,Z,ZA)-D
AC30(A)-(F,N)02~(F,N)03(C,D,E,E1,E2,E3,E4,G,M)-(1,2,3,6,8,J,N,R,W,Z,ZA)-D
AC30B,C,D -(F,N)02~(F,N)03(C,D,E,E1,E2,E3,E4,G,M)-(1,2,6,8,J,N,R,W,Z,ZA)-D
AC40(A)-(F,N)02~(F,N)04(C,D,E,E1,E2,E3,E4,G,M)-(1,2,3,6,8,J,N,R,W,Z,ZA)-D
AC40B,C,D -(F,N)02~(F,N)04(C,D,E,E1,E2,E3,E4,G,M)-(1,2,6,8,J,N,R,W,Z,ZA)-D
AC40(A)-(F,N)06(C,D,E,E1,E2,E3,E4,G,M)-(1,2,3,6,8,J,N,R,W,Z,ZA)-D
AC40B,C,D-(F,N)06(C,D,E,E1,E2,E3,E4,G,M)-(1,2,6,8,J,N,R,W,Z,ZA)-D
AC50(A)-(F,N)06~(F,N)10(C,D,E,E1,E2,E3,E4,G,M)-(1,2,3,6,8,J,N,R,W,Z,ZA)-D
AC50B-(F,N)06~(F,N)10 (C,D,E,E1,E2,E3,E4,G,M)-(1,2,6,8,J,N,R,W,Z,ZA)-D
AC60(A)-(F,N)10(C,D,E,E1,E2,E3,E4,G,M)-(1,2,3,6,8,J,N,R,W,Z,ZA)-D
AC60B-(F,N)10(C,D,E,E1,E2,E3,E4,G,M)-(1,2,6,8,J,N,R,W,Z,ZA)-D

SMC Corporation

Contents

	Page
1. Safety Instructions	2-10
2. Application	11
3. Specifications	11-15
4. How to Order	16-20
5. Options	21
6. Structural Drawing and Replacement Part	21
7. Trouble Shooting	22
8. How to Replace the Products	23
9. Disassembly Drawing	24
10. Dimensions	25-29



Safety Instructions

These safety instructions are intended to prevent hazardous situations and/or equipment damage. These instructions indicate the level of potential hazard with the labels of "Caution," "Warning" or "Danger." They are all important notes for safety and must be followed in addition to International Standards (ISO/IEC)*1), and other safety regulations.

*1) ISO 4414: Pneumatic fluid power -- General rules relating to systems.

ISO 4413: Hydraulic fluid power -- General rules relating to systems.

IEC 60204-1: Safety of machinery -- Electrical equipment of machines .(Part 1: General requirements)

ISO 10218: Manipulating industrial robots -Safety.

etc.



Caution

Caution indicates a hazard with a low level of risk which, if not avoided, could result in minor or moderate injury.



Warning

Warning indicates a hazard with a medium level of risk which, if not avoided, could result in death or serious injury.



Danger

Danger indicates a hazard with a high level of risk which, if not avoided, will result in death or serious injury.

Warning

1. The compatibility of the product is the responsibility of the person who designs the equipment or decides its specifications.

Since the product specified here is used under various operating conditions, its compatibility with specific equipment must be decided by the person who designs the equipment or decides its specifications based on necessary analysis and test results.

The expected performance and safety assurance of the equipment will be the responsibility of the person who has determined its compatibility with the product.

This person should also continuously review all specifications of the product referring to its latest catalog information, with a view to giving due consideration to any possibility of equipment failure when configuring the equipment.

2. Only personnel with appropriate training should operate machinery and equipment.

The product specified here may become unsafe if handled incorrectly.

The assembly, operation and maintenance of machines or equipment including our products must be performed by an operator who is appropriately trained and experienced.

3. Do not service or attempt to remove product and machinery/equipment until safety is confirmed.

1. The inspection and maintenance of machinery/equipment should only be performed after measures to prevent falling or runaway of the driven objects have been confirmed.

2. When the product is to be removed, confirm that the safety measures as mentioned above are implemented and the power from any appropriate source is cut, and read and understand the specific product precautions of all relevant products carefully.

3. Before machinery/equipment is restarted, take measures to prevent unexpected operation and malfunction.

4. Contact SMC beforehand and take special consideration of safety measures if the product is to be used in any of the following conditions.

1. Conditions and environments outside of the given specifications, or use outdoors or in a place exposed to direct sunlight.

2. Installation on equipment in conjunction with atomic energy, railways, air navigation, space, shipping, vehicles, military, medical treatment, combustion and recreation, or equipment in contact with food and beverages, emergency stop circuits, clutch and brake circuits in press applications, safety equipment or other applications unsuitable for the standard specifications described in the product catalog.

3. An application which could have negative effects on people, property, or animals requiring special safety analysis.

4. Use in an interlock circuit, which requires the provision of double interlock for possible failure by using a mechanical protective function, and periodical checks to confirm proper operation.



Safety Instructions

Caution

The product is provided for use in manufacturing industries.

The product herein described is basically provided for peaceful use in manufacturing industries.

If considering using the product in other industries, consult SMC beforehand and exchange specifications or a contract if necessary.

If anything is unclear, contact your nearest sales branch.

Limited warranty and Disclaimer/Compliance Requirements

The product used is subject to the following “Limited warranty and Disclaimer” and “Compliance Requirements”.

Read and accept them before using the product.

Limited warranty and Disclaimer

1. The warranty period of the product is 1 year in service or 1.5 years after the product is delivered, whichever is first.*2)

Also, the product may have specified durability, running distance or replacement parts. Please consult your nearest sales branch.

2. For any failure or damage reported within the warranty period which is clearly our responsibility, a replacement product or necessary parts will be provided.

This limited warranty applies only to our product independently, and not to any other damage incurred due to the failure of the product.

3. Prior to using SMC products, please read and understand the warranty terms and disclaimers noted in the specified catalog for the particular products.

*2) Vacuum pads are excluded from this 1 year warranty.

A vacuum pad is a consumable part, so it is warranted for a year after it is delivered.

Also, even within the warranty period, the wear of a product due to the use of the vacuum pad or failure due to the deterioration of rubber material are not covered by the limited warranty.

Compliance Requirements

1. The use of SMC products with production equipment for the manufacture of weapons of mass destruction(WMD) or any other weapon is strictly prohibited.

2. The exports of SMC products or technology from one country to another are governed by the relevant security laws and regulation of the countries involved in the transaction. Prior to the shipment of a SMC product to another country, assure that all local rules governing that export are known and followed.

Caution

SMC products are not intended for use as instruments for legal metrology.

Measurement instruments that SMC manufactures or sells have not been qualified by type approval tests relevant to the metrology (measurement) laws of each country.

Therefore, SMC products cannot be used for business or certification ordained by the metrology (measurement) laws of each country.

Precautions for Design

Warning

- (1) Consult SMC if no leakage is allowed due to the environment, or if the operating fluid is not air.
- (2) Polycarbonate resin is used for the external parts including the bowl. Organic solvents including thinner, acetone, alcohol and ethylene chloride; chemicals including sulphuric acid, nitric acid and hydrochloric acid; cutting oil, synthetic oils, ester-based compressor oil, alkali, kerosene, gasoline, lock material of screw are harmful. Do not use the product where these are present.

Chemical resistance of polycarbonate and nylon bowl

Type	Chemical name	Application examples	Material	
			Polycarbonate	Nylon
Acid	Hydrochloric acid Sulfuric acid Phosphoric acid Chromic acid	Acid washing liquid for metals	△	×
Alkaline	Sodium hydroxide (Caustic soda) Potash Calcium hydroxide (Slack lime) Ammonia water Carbotane of soda	Degreasing of metals Industrial salts Water-soluble cutting oil	×	○
Inorganic salts	Sodium sulfide Potassium nitrate Sulfate of soda	-	×	△
Chlorine solvents	Carbon tetrachloride Chloroform Ethylene chloride Methylene chloride	Cleaning liquid for metals Printing ink Dilution	×	△
Aromatic series	Benzene Toluene Paint thinner	Coatings Dry cleaning	×	△
Ketone	Acetone Methyl ethyl ketone Cyclohexane	Photographic film Dry cleaning Textile industries	×	×
Alcohol	Ethyl alcohol IPA Methyl alcohol	Antifreeze Adhesives	△	×
Oil	Gasoline Kerosene	-	×	○
Ester	Phthalic acid dimethyl Phthalic acid diethyl Acetic acid	Synthetic oil Anti-rust additives	×	○
Ether	Methyl ether Ethyl ether	Brake oil additives	×	○
Amino	Methyl amino	Cutting oil Brake oil additives Rubber accelerator	×	×
Others	Thread-lock fluid Sea water Leak tester	-	×	△

○: Essentially safe. △: Some effects may occur. ×: Effects will occur.

When the above factors are present or there is some doubt, use a metal bowl for safety.

- (3) Shield from ultra violet light and radiation with protective cover.

○ Air filter, lubricator, filter regulator and mist separator

- (1) Avoid the application where charge and discharge of pressure to/from a standard bowl is switched frequently. This may damage the bowl. A metal bowl is recommended in these cases.

○ Regulator and filter regulator

- (1) A safety device needs to be installed if output pressure is exceeding the set pressure, otherwise this can cause breakage of outlet device and equipment or lead to malfunction.

⚠ Caution

○ Air filter, filter regulator and mist separator

- (1) AD27-D with auto drain may have leakage of accumulated drain during pressure exhaust (this leakage is allowed in their constructions and not considered failure). Be sure to connect piping for drain.

○ Regulator and filter regulator

- (1) Allowed air consumption from the exhaust port is 0.1 L/min(ANR) or less.

Selection

⚠ Warning

○ Air combination

- (1) Grease used on the internal sliding parts and seals may flow to the outlet side. If this is not acceptable, please consult SMC.

○ Air filter, filter regulator and mist separator

- (1) N.O. type auto drain should be operated under the following conditions to avoid malfunction.
Operating compressor: 0.75 kW or more, Discharged flow rate: 100 L/min (ANR) or more
When using 2 or more auto drains, multiply the value above by the number of auto drains to find the capacity of the compressors you will need. For example, when using 2 auto drains, 1.5 kW (200 L/min (ANR)) of the compressor capacity is required. The operating pressure should be 0.1 MPa or more.
- (2) N.C. type auto drain should be operated under the following conditions to avoid malfunction.
Operating pressure for AD27: 0.1 MPa or more, for AD37 and AD47: 0.15 MPa or more.

○ Regulator and filter regulator

- (1) Residual pressure of product without backflow function is released unstably even though the inlet pressure is released (residual pressure might be left in the product). Please select product with backflow function to release the residual pressure completely.
- (2) Long absence of operation or operation with sealed circuit or balancing circuit on the outlet side may cause set pressure fluctuation. Please consult SMC if this is not acceptable.
- (3) Set range of outlet pressure shall be 85% or less of the inlet pressure. Operating at a setting exceeding 85% causes the outlet pressure to be easily affected by fluctuations in flow rate and inlet pressure, leading to instability.
- (4) Since the safety margin is calculated to the maximum value of the set pressure range shown in the specification table, the pressure setting may be over the maximum value. However, use the product within the specified range.
- (5) If the product is used with circuit which requires high exhaust sensitivity or set precision, please consult SMC.

○ Lubricator

- (1) Please consult SMC when the lubricator is used other than for lubricating pneumatic equipment.
- (2) Please consult SMC when the lubricator is used at high frequency, such as press machine, as the internal components may break or operation failure may occur on the outlet side equipment.
- (3) If the air consumption is small, oil may not drip. Select a proper size of product according to the minimum dripping flow rate.
- (4) Do not flow from the outlet side (backflow) as it may cause breakage of the internal components.
- (5) When the piping is branched on the inlet side, install a check valve to prevent the lubricant from back flowing.

Installation

Warning

○ Air combination

- (1) Do not drop or apply impact during transportation or installation. It will cause damage to the product and result in operation failure.
- (2) Do not install in areas of high humidity or high temperature. Operation outside of the product specification range may cause damage to the product or operation failure, or shorten the product life.
- (3) Connect the product ensuring the direction of "1"(IN) and "2"(OUT) for air direction and indicated arrow. Incorrect connections may cause malfunction.
- (4) Install with adequate space for maintenance beneath the product. Refer to the dimensional drawings for necessary space.
- (5) Tighten the two set screws on the spacer with bracket and spacer evenly. Tighten them to the recommended tightening torque. Insufficient tightening torque may cause loosening or sealing failure, and excessive tightening torque may cause breakage of screws.

Recommended tightening torque

Unit: N m

Applicable models	AC20*-D	AC30*-D	AC40*-D	AC40*-06-D	AC50*-D AC60*-D
Part No. of spacer with bracket	Y200T-D	Y300T-D	Y400T-D	Y500T-D	Y600T-D
Part No. of spacer	Y200-D	Y300-D	Y400-D	Y500-D	Y600-D
Torque	0.36+/-0.036	1.2+/-0.05	1.2+/-0.05	1.4+/-0.05	2.0+/-0.1

○ Air filter, filter regulator and mist separator

- (1) Install vertically so that outlet of drain is downward. It cannot be used in horizontal or upward direction as it may cause operation failure.

○ Lubricator

- (1) Install the lubricator vertically so that the bowl is downward. It cannot be used in horizontal or upward direction.

Caution

○ Air combination

- (1) When the air combination is fixed on the wall with hexagon socket head cap screws, ballpoint driver is recommended as a tool.

○ Air filter, filter regulator and mist separator

- (1) Install the bowl so that the lock button lines up to the groove of the front (or the back) of the body to avoid drop or damage of the bowl.

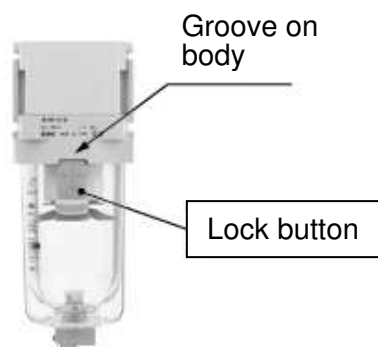

Adjustment

Warning

○ Regulator and filter regulator

- (1) Adjust the set pressure ensuring correct inlet and outlet pressures. Turning the knob excessively can cause damage to the internal parts.
- (2) Do not use tools on the pressure regulator knob as this may cause damage. It must be operated manually.

○ Lubricator

- (1) Adjustment of the oil regulating valve should be carried out manually. The use of tools etc. can result in damage to the unit.
- (2) Turning the oil regulating valve counterclockwise increases the dripping amount, and turning it clockwise reduces the dripping amount. From the fully closed position, three rotations will bring it to the fully open position. Do not rotate it any further than this. Note that the numbered scale markings are guidelines for adjusting the position, and not indicators of the dripping amount.

Caution

○ Regulator and filter regulator

- (1) Check the inlet pressure before setting up.
- (2) Be sure to unlock the knob before adjusting the pressure and lock it after setting the pressure. Failure to follow this procedure can cause damage to the knob and the outlet pressure may fluctuate.
 - Pull the pressure regulator knob to unlock (You can visually verify this with the “orange mark” that appears in the gap).
 - Push the pressure regulator knob to lock. When the knob is not easily locked, turn it left and right a little and then push it (when the knob is locked, the “orange mark”, i.e., the gap will disappear).
- (3) For the product with a pressure gauge, do not apply pressure exceeding the maximum scale of the pressure gauge in order to protect the gauge.
- (4) Adjust the pressure whilst the pressure is increasing. Pressure may become lower than the set pressure if adjusted by decreasing the value. Rotate the knob clockwise to increase the set pressure. Counterclockwise to decrease the pressure. Moreover, please lock the knob after setting pressure.
- (5) Outlet pressure may rise when the inlet pressure is discharged and resupplied after pressure setting. In this case, consume air at the outlet which will bring the pressure closer to the set pressure.
- (6) Outlet pressure may change if the product is used for a long period of time. Please confirm the set pressure regularly.

Piping



Warning

○ Air combination

- (1) Before piping is connected, it should be thoroughly blown out with air (flushing) or washed to remove chips, cutting oil and solid foreign material from inside the pipe. Contamination of piping may cause damage or malfunction.
- (2) When screwing together pipes and fittings, etc., be certain that chips from the pipe threads and sealant do not get inside the pipe. When a sealant tape is used, leave 1.5 to 2 thread ridges exposed at the end of the threads.
- (3) Connect piping/fittings using the recommended torque while holding the female thread side tightly. Insufficient tightening torque leads to cause of loosening or sealing failure, and excessive tightening torque leads to cause of breakage of screws. Tightening without holding female thread applies an excessive force to the piping bracket directly, leading to breakage.

Recommended tightening torque

Unit: N m

Thread size	1/8	1/4	3/8	1/2	3/4	1
Torque	3 to 5	8 to 12	15 to 20	20 to 25	28 to 30	36 to 38

- (4) Before using an SMC fitting and S coupler, please refer to "Tightening the threaded portion of the connection thread" of the Fittings & Tubing Precautions.
- (5) Do not apply torsion or bending moment other than the weight of the product itself. External piping needs to be supported separately as it may cause breakage. If moment applied to the equipment is unavoidable during operation, the moment should be lower than the maximum moment shown below. Non-flexible piping like steel tube is susceptible to excessive moment load or vibration. Insert flexible tubes to prevent this.

Body size	20	30	40	40-06	50	60
Max. moment (M) [N m]	14.5	16	19.5	35	45	45

Max. moment (M) = Length (L) x Load (F)

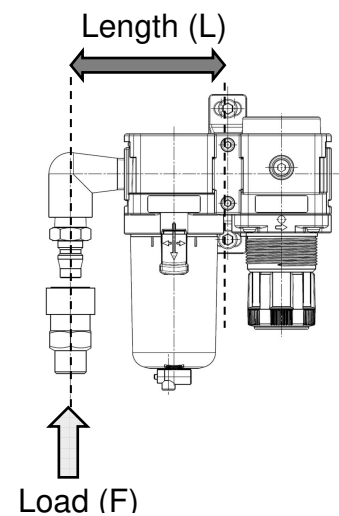

○ Air filter, filter regulator and mist separator

- (1) Drain guide is not equipped with valve function. Be sure to connect piping for drain. No piping for drain allows the drain and compressed air to exhaust freely. Also, the piping installation should be performed with drain guide held by spanner to prevent breakage of bowl.
- (2) The piping for drain from auto drain should be connected under the following requirements to avoid operating failure.

Tubing for AD27-D: I.D. $\phi 2.5$ ($\phi 3/32$ ") or larger, Length 5 m (200 inch) or shorter

Tubing for AD37, 47(N)-D: I.D. $\phi 4$ ($\phi 3/16$ ") or larger, Length 5 m (200 inch) or shorter

Tubing for AD38, 48(N)-D: I.D. $\phi 6.5$ ($\phi 1/4$ ") or larger, Length 5 m (200 inch) or shorter



Caution

○ Lubricator

- (1) Avoid rising piping and piping branches on the outlet piping. Otherwise, lubricating failure may occur.

Air Source

Warning

○ Air combination

- (1) Use clean air. Do not use compressed air containing chemicals, organic solvent, synthetic oil or corrosive gas as it may be cause of breakage of components or operation failure.
- (2) Use an air filter with 5 µm or less filtration rating on the inlet side of the valve to avoid any damage to the seat caused by dust when mounting a pressure relief 3 port valve.
- (3) Air containing too much moisture may cause malfunction. Install an air drier or aftercooler before the air combination.

Maintenance

Warning

○ Air combination

- (1) Maintenance and checks should be done by following the procedure in this operation manual. Incorrect handling of the product may cause breakage or operation failure of the equipment or device.

○ Air filter, lubricator, filter regulator and mist separator

- (1) Perform periodical check to find cracks, flaws or other deterioration on resin bowl. If any of these appear, replace with new parts. Otherwise, breakage may occur. Investigate and/or review the operating conditions if necessary.
- (2) Check for dirt in resin bowl periodically. If any dirt is seen, replace with new bowl. If removing dirt by washing the resin bowl, never use washing material other than neutral detergent. Otherwise, the bowl is damaged.
- (3) Open and close the drain cock manually. The use of tools can result in damage to the product.

○ Air filter, filter regulator and mist separator

- (1) Replace the element every 2 years or when the pressure drop at the output pressure from initial operation becomes 0.1 MPa, whichever comes first, to prevent damage to the element.
- (2) Discharge drain from the bowl before the drain level in the bowl reaches baffle. If drain enters the outlet side, it can cause operation failure of the equipment.

○ Lubricator

- (1) Use class 1 turbine oil (with no additives) ISO VG32. Using other lubricant can cause damage to devices and result in malfunction.
- (2) AL20-D cannot replenish lubricate while being pressurized. Before lubrication, exhaust the inlet pressure and make sure that there is no pressure in the bowl.
- (3) AL30-D, AL40-D, AL50-D and AL60-D have a small amount of leakage from the bowl to oil supply port. Slowly loosen the oil supply plug approximately 1 turn and wait until the pressure in the bowl is released, and then, remove the oil supply plug. Be sure to wear safety goggles when removing the oil supply plug as the pressure in the bowl is released. After removing the oil supply plug, supply oil slowly up to the upper limit of oil level while ensuring that no oil film is created over the oil supply port.
After supplying oil, confirm that the O-ring on the oil supply plug is mounted correctly and mount the oil supply plug. It returns to the original condition by pushing the oil supply plug lightly.

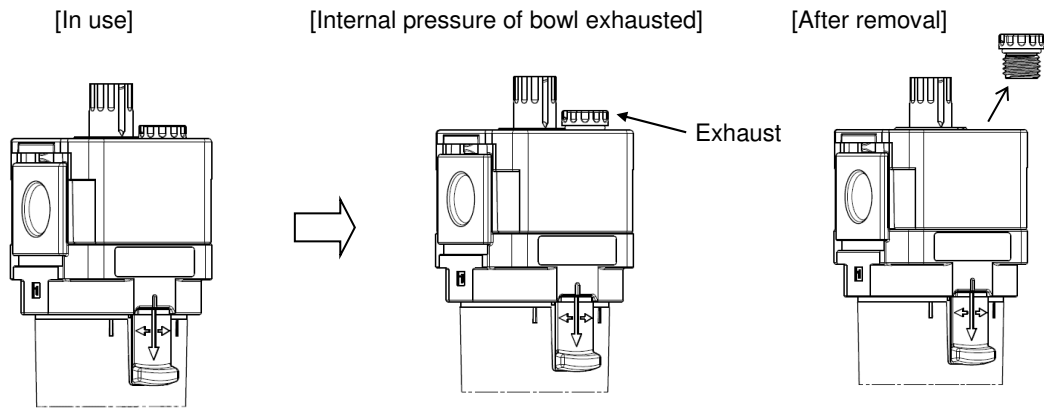

⚠ Caution

○ Regulator and filter regulator

- (1) If an emergency countermeasure is to be taken during setting failure or exhaust leakage, the internal valve seating part should be checked. If failure such as foreign matter is found, remove it before performing the emergency countermeasure.

○ Air filter, filter regulator and mist separator

- (1) Rotate the knob counterclockwise (O←direction) to exhaust drain from the C2SF(-C)-D. Press the push button to exhaust drain from the C3SF(-W)-D and C4SF(-W)-D.
- (2) Check the element periodically and replace it with a new one if necessary. If it is found that outlet pressure drops lower than the normal condition or the flow is restricted during operation, check the condition of the element.
- (3) The emergency manual exhaust of AD27-D can be performed by rotating the knob counterclockwise (O←direction).
The emergency manual exhaust of AD37, 38, 47 and 48-D can be performed by rotating the drain cock counterclockwise (O←direction).

○ Lubricator

- (1) Check the dripping amount once a day. Drip failure can cause damage to the components that need lubrication.
- (2) Use clean oil. Otherwise, it may cause dripping failure or clogging.
- (3) The lubrication amount should be less than the upper limit of oil level of the bowl.
- (4) Discharge drain periodically so that the drain is not accumulated beyond the upper limit of the drain level of the bowl. If a large amount of drain enters lubricator, it may cause dripping failure.

2. Application

This product is used in combination with components which aim to eliminate a certain amount of water vapor and solid foreign matter in the air line, lubricating and controlling pressure of pneumatic products or solenoid valves.

3. Standard Specifications

3-1. AC20-D to AC60-D

Model		AC20-D	AC30-D	AC40-D	AC40-06-D	AC50-D	AC60-D
Component	Air filter [AF]	AF20-D	AF30-D	AF40-D	AF40-06-D	AF50-D	AF60-D
	Regulator [AR]	AR20-D	AR30-D	AR40-D	AR40-06-D	AR50-D	AR60-D
	Lubricator [AL]	AL20-D	AL30-D	AL40-D	AL40-06-D	AL50-D	AL60-D
Port size		1/8, 1/4	1/4, 3/8	1/4, 3/8, 1/2	3/4	3/4, 1	1
Pressure gauge port size ^{Note 1)} [AR]		1/8					
Fluid		Air					
Ambient and fluid temperature ^{Note 2)}		-5 to 60 °C (with no freezing)					
Proof pressure		1.5 MPa					
Max. operating pressure		1.0 MPa					
Min. operating pressure of auto drain	N.C. [AF]	0.1 MPa	0.15 MPa				
	N.O. [AF]	–	0.1 MPa				
Set pressure range [AR]		0.05 to 0.85 MPa					
Filtration rating [AF]		5 μm					
Compressed air quality class ^{Note 3)}		ISO8573-1:2010 [6:4-]					
Drain capacity [AF]		8 cm ³	25 cm ³	45 cm ³			
Min. dripping flow rate ^{Note 4)} [AL]		15 L/min (ANR)	Port size 1/4: 30 L/min(ANR) Port size 3/8: 40 L/min(ANR)	Port size 1/4: 30 L/min(ANR) Port size 3/8: 40 L/min(ANR) Port size 1/2: 50 L/min(ANR)	50 L/min(ANR)	190 L/min(ANR)	220 L/min(ANR)
Oil capacity [AL]		25 cm ³	55 cm ³	135 cm ³			
Recommended lubricant [AL]		Class 1 turbine oil (ISO VG32)					
Bowl material [AF/AL]		Polycarbonate					
Bowl guard [AF/AL]		Semi-standard (Steel)	Standard (Polycarbonate)				
Construction [AR]		Relieving type					
Weight		0.38 kg	0.75 kg	1.42 kg	1.55 kg	3.34 kg	3.60 kg

Note 1) Pressure gauge connection threads are not available for F.R.L. unit with a square embedded type pressure gauge or with a digital pressure switch.

Note 2) -5 to 50°C for the products with the digital pressure switch.

Note 3) Based on ISO8573-1:2010 Compressed air - Part 1: Contaminants and purity classes.

The compressed air quality class on the inlet side is [7:4:4].

Note 4) - The flow rate is 5 drops/min under the following conditions: Inlet pressure of 0.5 MPa; Class 1 turbine oil (ISO VG32); Temperature at 20°C; Oil adjustment valve fully open.

- For a circuit that repeatedly turns ON and OFF on the outlet side, make the adjustment so that the average air consumption per minute becomes equal to the minimum dripping flow rate or more.

3-2. AC20A-D to AC60A-D

Model		AC20A-D	AC30A-D	AC40A-D	AC40A-06-D	AC50A-D	AC60A-D
Component	Filter regulator [AW]	AW20-D	AW30-D	AW40-D	AW40-06-D	AW60-D	AW60-D
	Lubricator [AL]	AL20-D	AL30-D	AL40-D	AL40-06-D	AL50-D	AL60-D
Port size		1/8, 1/4	1/4, 3/8	1/4, 3/8, 1/2	3/4	3/4, 1	1
Pressure gauge port size ^{Note 1)} [AW]		1/8					
Fluid		Air					
Ambient and fluid temperature ^{Note 2)}		-5 to 60 °C (with no freezing)					
Proof pressure		1.5 MPa					
Max. operating pressure		1.0 MPa					
Min. operating pressure of auto drain	N.C. [AW]	0.1 MPa	0.15 MPa				
	N.O. [AW]	–	0.1 MPa				
Set pressure range [AW]		0.05 to 0.85 MPa					
Filtration rating [AW]		5 µm					
Compressed air quality class ^{Note 3)}		ISO8573-1:2010 [6:4-]					
Drain capacity [AW]		8 cm ³	25 cm ³	45 cm ³			
Min. dripping flow rate ^{Note 4)} [AL]		15 L/min(ANR)	Port size 1/4: 30 L/min(ANR) Port size 3/8: 40 L/min(ANR)	Port size 1/4: 30 L/min(ANR) Port size 3/8: 40 L/min(ANR) Port size 1/2: 50 L/min(ANR)	50 L/min(ANR)	190 L/min(ANR)	220 L/min(ANR)
Oil capacity [AL]		25 cm ³	55 cm ³	135 cm ³			
Recommended lubricant [AL]		Class 1 turbine oil (ISO VG32)					
Bowl material [AW/AL]		Polycarbonate					
Bowl guard [AW/AL]		Semi-standard (Steel)	Standard (Polycarbonate)				
Construction [AW]		Relieving type					
Weight		0.31 kg	0.58 kg	1.12 kg	1.22 kg	2.90 kg	2.97 kg

Note 1) Pressure gauge connection threads are not available for F.R.L. unit with a square embedded type pressure gauge or with a digital pressure switch.

Note 2) -5 to 50°C for the products with the digital pressure switch.

Note 3) Based on ISO8573-1:2010 Compressed air - Part 1: Contaminants and purity classes.

The compressed air quality class on the inlet side is [7:4:4].

Note 4) - The flow rate is 5 drops/min under the following conditions: Inlet pressure of 0.5 MPa; Class 1 turbine oil (ISO VG32); Temperature at 20°C; Oil adjustment valve fully open.

- For a circuit that repeatedly turns ON and OFF on the outlet side, make the adjustment so that the average air consumption per minute becomes equal to the minimum dripping flow rate or more.

3-3. AC20B-D to AC60B-D

Model		AC20B-D	AC30B-D	AC40B-D	AC40B-06-D	AC50B-D	AC60B-D
Component	Filter [AF]	AF20-D	AF30-D	AF40-D	AF40-06-D	AF50-D	AF60-D
	Regulator [AR]	AR20-D	AR30-D	AR40-D	AR40-06-D	AR50-D	AR60-D
Port size		1/8, 1/4	1/4, 3/8	1/4, 3/8, 1/2	3/4	3/4, 1	1
Pressure gauge port size ^{Note 1)} [AR]		1/8					
Fluid		Air					
Ambient and fluid temperature ^{Note 2)}		-5 to 60 °C (with no freezing)					
Proof pressure		1.5 MPa					
Max. operating pressure		1.0 MPa					
Min. operating pressure of auto drain	N.C. [AF]	0.1 MPa	0.15 MPa				
	N.O. [AF]	–	0.1 MPa				
Set pressure range [AR]		0.05 to 0.85 MPa					
Filtration rating [AF]		5 µm					
Compressed air quality class ^{Note 3)}		ISO8573-1:2010 [6:4:4]					
Drain capacity [AF]		8 cm ³	25 cm ³	45 cm ³			
Bowl material [AF]		Polycarbonate					
Bowl guard [AF]		Semi-standard (Steel)	Standard (Polycarbonate)				
Construction [AR]		Relieving type					
Weight		0.25 kg	0.51 kg	0.95 kg	1.02 kg	2.20 kg	2.39 kg

Note 1) Pressure gauge connection threads are not available for F.R.L. unit with a square embedded type pressure gauge or with a digital pressure switch.

Note 2) -5 to 50°C for the products with the digital pressure switch.

Note 3) Based on ISO8573-1:2010 Compressed air - Part 1: Contaminants and purity classes.

The compressed air quality class on the inlet side is [7:4:4].

3-4. AC20C-D to AC40C-D

Model		AC20C-D	AC30C-D	AC40C-D	AC40C-06-D
Component	Filter [AF]	AF20-D	AF30-D	AF40-D	AF40-06-D
	Mist separator [AFM]	AFM20-D	AFM30-D	AFM40-D	AFM40-06-D
	Regulator [AR]	AR20-D	AR30-D	AR40-D	AR40-06-D
Port size		1/8, 1/4	1/4, 3/8	1/4, 3/8, 1/2	3/4
Pressure gauge port size ^{Note 1)} [AR]		1/8			
Fluid		Air			
Ambient and fluid temperature ^{Note 2)}		-5 to 60 °C (with no freezing)			
Proof pressure		1.5 MPa			
Max. operating pressure		1.0 MPa			
Min. operating pressure of auto drain	N.C. [AF/AFM]	0.1 MPa	0.15 MPa		
	N.O. [AF/AFM]	–	0.1 MPa		
Set pressure range [AR]		0.05 to 0.85 MPa			
Max. air flow capacity ^{Note 3)} [AFM]		200 L/min(ANR)	450 L/min(ANR)	1,100 L/min(ANR)	
Filtration rating	[AF]	5 µm			
	[AFM]	0.3 µm (99.9% filtered particle size)			
Outlet side oil mist concentration [AFM]		Max. 1.0 mg/m ³ (≒0.8 ppm)			
Compressed air quality class ^{Note 4)}		ISO8573-1:2010 [3:4:3]			
Drain capacity [AF/AFM]		8 cm ³	25 cm ³	45 cm ³	
Bowl material [AF/AFM]		Polycarbonate			
Bowl guard [AF/AFM]		Semi-standard (Steel)	Standard (Polycarbonate)		
Construction [AR]		Relieving type			
Weight		0.38 kg	0.75 kg	1.42 kg	1.54 kg

Note 1) Pressure gauge connection threads are not available for F.R.L. unit with a square embedded type pressure gauge or with a digital pressure switch.

Note 2) -5 to 50°C for the products with the digital pressure switch.

Note 3) When the mist separator inlet pressure is: 0.7 MPa; at 20°C, atmospheric pressure, and relative humidity of 65%.

The maximum air flow capacity varies depending on the inlet pressure. Keep the air flow below the maximum air flow capacity to prevent an outflow of lubricant to the outlet side.

Note 4) Based on ISO8573-1:2010 Compressed air - Part 1: Contaminants and purity classes.

The compressed air quality class on the inlet side is [7:4:4].

3-5. AC20D-D to AC40D-D

Model		AC20D-D	AC30D-D	AC40D-D	AC40D-06-D
Component	Filter regulator [AW]	AW20-D	AW30-D	AW40-D	AW40-06-D
	Mist separator [AFM]	AFM20-D	AFM30-D	AFM40-D	AFM40-06-D
Port size		1/8, 1/4	1/4, 3/8	1/4, 3/8, 1/2	3/4
Pressure gauge port size ^{Note 1)} [AW]		1/8			
Fluid		Air			
Ambient and fluid temperature ^{Note 2)}		-5 to 60 °C (with no freezing)			
Proof pressure		1.5 MPa			
Max. operating pressure		1.0 MPa			
Min. operating pressure of auto drain	N.C. [AW/AFM]	0.1 MPa	0.15 MPa		
	N.O. [AW/AFM]	–	0.1 MPa		
Set pressure range [AW]		0.05 to 0.85 MPa			
Max. air flow capacity ^{Note 3)} [AFM]		200 L/min(ANR)	450 L/min(ANR)	1,100 L/min(ANR)	
Filtration rating	[AW]	5 µm			
	[AFM]	0.3 µm (99.9% filtered particle size)			
Outlet oil mist concentration [AFM]		MAX. 1.0mg/m ³ (≒0.8ppm)			
Compressed air quality class ^{Note 4)}		ISO8573-1:2010 [3:4:3]			
Drain capacity [AW/AFM]		8 cm ³	25 cm ³	45 cm ³	
Bowl material [AW/AFM]		Polycarbonate			
Bowl guard [AW/AFM]		Semi-standard (Steel)	Standard (Polycarbonate)		
Construction [AW]		Relieving type			
Weight		0.30 kg	0.58 kg	1.12 kg	1.21 kg

Note 1) Pressure gauge connection threads are not available for F.R.L. unit with a square embedded type pressure gauge or with a digital pressure switch.

Note 2) -5 to 50°C for the products with the digital pressure switch.

Note 3) When the mist separator inlet pressure is: 0.7 MPa; at 20°C, atmospheric pressure, and relative humidity of 65%.

The maximum air flow capacity varies depending on the inlet pressure. Keep the air flow below the maximum air flow capacity to prevent an outflow of lubricant to the outlet side.

Note 4) Based on ISO8573-1:2010 Compressed air - Part 1: Contaminants and purity classes.

The compressed air quality class on the inlet side is [7:4:4].

4. How to Order

4-1. AC20-D to AC60-D

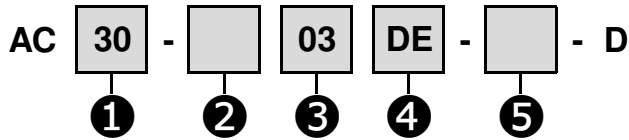

		Symbol	Description	①						
				Body size						
				20	30	40	50	60		
②	Thread type	Nil	Rc	●	●	●	●	●		
		N	NPT	●	●	●	●	●		
		F	G	●	●	●	●	●		
③	Port size	01	1/8	●	-	-	-	-		
		02	1/4	●	●	●	-	-		
		03	3/8	-	●	●	-	-		
		04	1/2	-	-	●	-	-		
		06	3/4	-	-	●	●	-		
		10	1	-	-	-	●	●		
④	Option	a	Float type auto drain	Nil	Without auto drain	●	●	●	●	●
				C	N.C. (Normally closed) Drain port is closed when pressure is not supplied.	●	●	●	●	●
				D	N.O. (Normally opened) Drain port is opened when pressure is not supplied.	-	●	●	●	●
		b	Pressure gauge	Nil	Without pressure gauge	●	●	●	●	●
				E	Square embedded type pressure gauge (with limit indicator)	●	●	●	●	●
				G	Round type pressure gauge (with limit indicator)	●	●	●	●	●
	Digital pressure switch		M	Round type pressure gauge (with color zone)	●	●	●	●	●	
			E1	NPN output / Wiring bottom entry	●	●	●	●	●	
			E2	NPN output/ Wiring top entry	●	●	●	●	●	
		E3	PNP output / Wiring bottom entry	●	●	●	●	●		
	E4	PNP output/ Wiring top entry	●	●	●	●	●			
	⑤	Semi-standard	c	Set pressure	Nil	0.05 to 0.85 MPa setting	●	●	●	●
1					0.02 to 0.2 MPa setting	●	●	●	●	●
d			Bowl	Nil	Polycarbonate bowl	●	●	●	●	●
				2	Metal bowl	●	●	●	●	●
				6	Nylon bowl	●	●	●	●	●
				8	Metal bowl with level gauge	-	●	●	●	●
				C	With bowl guard	●	-	-	-	-
				6C	With bowl guard (Nylon bowl)	●	-	-	-	-
e			Air filter drain port	Nil	With drain cock	●	●	●	●	●
				J	Drain guide 1/8	●	-	-	-	-
					Drain guide 1/4	-	●	●	●	●
				W	Drain cock with barb fitting	-	●	●	●	●
f			Lubricator lubricant exhaust port	Nil	Without drain cock	●	●	●	●	●
				3	Lubricator with drain cock	●	●	●	●	●
g			Exhaust mechanism	Nil	Relieving type	●	●	●	●	●
				N	Non-relieving type	●	●	●	●	●
h			Flow direction	Nil	Flow direction: Left to right	●	●	●	●	●
				R	Flow direction: Right to left	●	●	●	●	●
i			Unit indication	Nil	Product: MPa, °C Pressure gauge: MPa	○ Note 2)	○ Note 2)	○ Note 2)	○ Note 2)	○ Note 2)
				Z	Product: psi, °F Pressure gauge: psi (and MPa)	○ Note 2)	○ Note 2)	○ Note 2)	○ Note 2)	○ Note 2)
				ZA	Digital pressure switch: With unit selection function	△ Note3)	△ Note3)	△ Note3)	△ Note3)	△ Note3)

Note 1) ④Option and ⑤Semi-standard: Select one each for a to i.

Note 2) ○: For NPT thread type only.

Note 3) △: Select with an option E1, E2, E3 or E4.

4-2. AC20A-D to AC60A-D

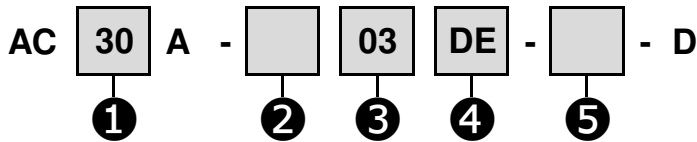

		Symbol	Description	①							
				Body size							
				20	30	40	50	60			
②	Thread type	Nil	Rc	●	●	●	●	●			
		N	NPT	●	●	●	●	●			
		F	G	●	●	●	●	●			
③	Port size	01	1/8	●	-	-	-	-			
		02	1/4	●	●	●	-	-			
		03	3/8	-	●	●	-	-			
		04	1/2	-	-	●	-	-			
		06	3/4	-	-	●	●	-			
		10	1	-	-	-	●	●			
		④	Option	a	Float type auto drain	Without auto drain	●	●	●	●	●
C	N.C. (Normally closed) Drain port is closed when pressure is not supplied.				●	●	●	●	●		
D	N.O. (Normally opened) Drain port is opened when pressure is not supplied.				-	●	●	●	●		
b	Pressure gauge			Nil	Without pressure gauge	●	●	●	●	●	
				E	Square embedded type pressure gauge (with limit indicator)	●	●	●	●	●	
				G	Round type pressure gauge (with limit indicator)	●	●	●	●	●	
	Digital pressure switch		M	Round type pressure gauge (with color zone)	●	●	●	●	●		
			E1	NPN output / Wiring bottom entry	●	●	●	●	●		
			E2	NPN output / Wiring top entry	●	●	●	●	●		
⑤	Semi-standard		c	Set pressure	Nil	0.05 to 0.85 MPa setting	●	●	●	●	●
				1	0.02 to 0.2 MPa setting	●	●	●	●	●	
			d	Bowl	Nil	Polycarbonate bowl	●	●	●	●	●
		2			Metal bowl	●	●	●	●	●	
		6			Nylon bowl	●	●	●	●	●	
		8			Metal bowl with level gauge	-	●	●	●	●	
		C			With bowl guard	●	-	-	-	-	
		6C			With bowl guard (Nylon bowl)	●	-	-	-	-	
		e	Filter regulator drain port	Nil	With drain cock	●	●	●	●	●	
				J	Drain guide 1/8	●	-	-	-	-	
				W	Drain cock with barb fitting	-	●	●	●	●	
		f	Lubricator lubricant exhaust port	Nil	Without drain cock	●	●	●	●	●	
3	Lubricator with drain cock			●	●	●	●	●			
g	Exhaust mechanism	Nil	Relieving type	●	●	●	●	●			
		N	Non-relieving type	●	●	●	●	●			
h	Flow direction	Nil	Flow direction: Left to right	●	●	●	●	●			
		R	Flow direction: Right to left	●	●	●	●	●			
i	Unit indication	Nil	Product: MPa, °C Pressure gauge: MPa	●	●	●	●	●			
		Z	Product: psi, °F Pressure gauge: psi (and MPa)	○ Note 2)	○ Note 2)	○ Note 2)	○ Note 2)	○ Note 2)			
		ZA	Digital pressure switch: With unit selection function	△ Note 3)	△ Note 3)	△ Note 3)	△ Note 3)	△ Note 3)			

Note 1) ④Option and ⑤Semi-standard: Select one each for a to i.

Note 2) ○: For NPT thread type only.

Note 3) △: Select with an option E1, E2, E3 or E4.

4-3. AC20B-D to AC60B-D

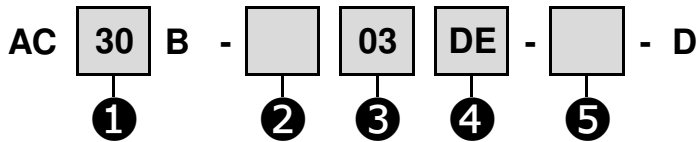

	Symbol	Description	①						
			Body size						
			20	30	40	50	60		
②	Thread type	Nil	Rc	●	●	●	●	●	
		N	NPT	●	●	●	●	●	
		F	G	●	●	●	●	●	
③	Port size	01	1/8	●	-	-	-	-	
		02	1/4	●	●	●	-	-	
		03	3/8	-	●	●	-	-	
		04	1/2	-	-	●	-	-	
		06	3/4	-	-	●	●	-	
		10	1	-	-	-	●	●	
④	a	Float type auto drain	Nil	Without auto drain	●	●	●	●	●
			C	N.C. (Normally closed) Drain port is closed when pressure is not supplied.	●	●	●	●	●
			D	N.O. (Normally opened) Drain port is opened when pressure is not supplied.	-	●	●	●	●
	b	Pressure gauge	Nil	Without pressure gauge	●	●	●	●	●
			E	Square embedded type pressure gauge (with limit indicator)	●	●	●	●	●
			G	Round type pressure gauge (with limit indicator)	●	●	●	●	●
		Digital pressure switch	M	Round type pressure gauge (with color zone)	●	●	●	●	●
			E1	NPN output / Wiring bottom entry	●	●	●	●	●
			E2	NPN output/ Wiring top entry	●	●	●	●	●
			E3	PNP output / Wiring bottom entry	●	●	●	●	●
E4	PNP output/ Wiring top entry	●	●	●	●	●			
⑤	c	Set pressure	Nil	0.05 to 0.85 MPa setting	●	●	●	●	●
			1	0.02 to 0.2 MPa setting	●	●	●	●	●
	d	Bowl	Nil	Polycarbonate bowl	●	●	●	●	●
			2	Metal bowl	●	●	●	●	●
			6	Nylon bowl	●	●	●	●	●
			8	Metal bowl with level gauge	-	●	●	●	●
			C	With bowl guard	●	-	-	-	-
			6C	With bowl guard (Nylon bowl)	●	-	-	-	-
	e	Air filter drain port	Nil	With drain cock	●	●	●	●	●
			J	Drain guide 1/8	●	-	-	-	-
			W	Drain cock with barb fitting	-	●	●	●	●
	f	Exhaust mechanism	Nil	Relieving type	●	●	●	●	●
			N	Non-relieving type	●	●	●	●	●
	g	Flow direction	Nil	Flow direction: Left to right	●	●	●	●	●
			R	Flow direction: Right to left	●	●	●	●	●
	h	Unit indication	Nil	Product: MPa, °C Pressure gauge: MPa	○ Note 2)	○ Note 2)	○ Note 2)	○ Note 2)	○ Note 2)
			Z	Product: psi, °F Pressure gauge: psi (and MPa)	○ Note 2)	○ Note 2)	○ Note 2)	○ Note 2)	○ Note 2)
			ZA	Digital pressure switch: With unit selection function	△ Note 3)	△ Note 3)	△ Note 3)	△ Note 3)	△ Note 3)

Note 1) ④Option and ⑤Semi-standard: Select one each for a to h.

Note 2) ○: For NPT thread type only.

Note 3) △: Select with an option E1, E2, E3 or E4.

4-4. AC20C-D to AC40C-D

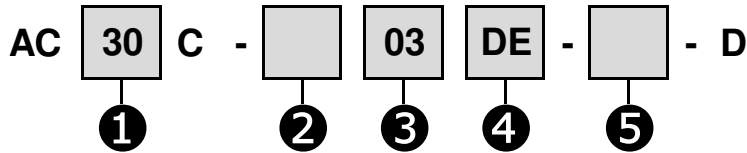

		Symbol	Description	①			
				Body size			
				20	30	40	
②	Thread type	Nil	Rc	●	●	●	
		N	NPT	●	●	●	
		F	G	●	●	●	
③	Port size	01	1/8	●	-	-	
		02	1/4	●	●	●	
		03	3/8	-	●	●	
		04	1/2	-	-	●	
		06	3/4	-	-	●	
		Nil	Without auto drain	●	●	●	
④	a	Float type auto drain	Nil	Without auto drain	●	●	●
		C	N.C. (Normally closed)	Drain port is closed when pressure is not supplied.	●	●	●
		D	N.O. (Normally opened)	Drain port is opened when pressure is not supplied.	-	●	●
	b	Pressure gauge	Nil	Without pressure gauge	●	●	●
			E	Square embedded type pressure gauge (with limit indicator)	●	●	●
			G	Round type pressure gauge (with limit indicator)	●	●	●
			M	Round type pressure gauge (with color zone)	●	●	●
		Digital pressure switch	E1	NPN output / Wiring bottom entry	●	●	●
			E2	NPN output/ Wiring top entry	●	●	●
	E3		PNP output / Wiring bottom entry	●	●	●	
	E4		PNP output/ Wiring top entry	●	●	●	
	⑤	c	Set pressure	Nil	0.05 to 0.85 MPa setting	●	●
1			0.02 to 0.2 MPa setting	●	●	●	
d		Bowl	Nil	Polycarbonate bowl	●	●	●
			2	Metal bowl	●	●	●
			6	Nylon bowl	●	●	●
			8	Metal bowl with level gauge	-	●	●
			C	With bowl guard	●	-	-
			6C	With bowl guard (Nylon bowl)	●	-	-
e		Air filter and mist separator drain port	Nil	With drain cock	●	●	●
			J	Drain guide 1/8	●	-	-
				Drain guide 1/4	-	●	●
			W	Drain cock with barb fitting	-	●	●
f		Exhaust mechanism	Nil	Relieving type	●	●	●
			N	Non-relieving type	●	●	●
g		Flow direction	Nil	Flow direction: Left to right	●	●	●
			R	Flow direction: Right to left	●	●	●
h		Unit indication	Nil	Product: MPa, °C Pressure gauge: MPa	●	●	●
			Z	Product: psi, °F Pressure gauge: psi (and MPa)	○ Note 2)	○ Note 2)	○ Note 2)
			ZA	Digital pressure switch: With unit selection function	△ Note3)	△ Note3)	△ Note3)

Note 1) ④Option and ⑤Semi-standard: Select one each for a to h.

Note 2) ○: For NPT thread type only.

Note 3) △: Select with an option E1, E2, E3 or E4.

4-5. AC20D-D to AC40D-D

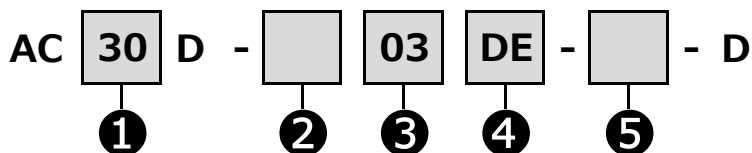

		Symbol	Description	①					
				Body size					
				20	30	40			
②	Thread type	Nil	Rc	●	●	●			
		N	NPT	●	●	●			
		F	G	●	●	●			
③	Port size	01	1/8	●	-	-			
		02	1/4	●	●	●			
		03	3/8	-	●	●			
		04	1/2	-	-	●			
		06	3/4	-	-	●			
④	Option	a	Float type auto drain	Nil	Without auto drain	●	●	●	
			C	N.C. (Normally closed)	Drain port is closed when pressure is not supplied.	●	●	●	
			D	N.O. (Normally opened)	Drain port is opened when pressure is not supplied.	-	●	●	
		b	Pressure gauge	Nil	Without pressure gauge	●	●	●	
				E	Square embedded type pressure gauge (with limit indicator)	●	●	●	
				G	Round type pressure gauge (with limit indicator)	●	●	●	
	Digital pressure switch	M	Round type pressure gauge (with color zone)	●	●	●			
		E1	NPN output / Wiring bottom entry	●	●	●			
		E2	NPN output / Wiring top entry	●	●	●			
		E3	PNP output / Wiring bottom entry	●	●	●			
	⑤	Semi-standard	c	Set pressure	Nil	0.05 to 0.85 MPa setting	●	●	●
				1	0.02 to 0.2 MPa setting	●	●	●	
d			Bowl	Nil	Polycarbonate bowl	●	●	●	
				2	Metal bowl	●	●	●	
				6	Nylon bowl	●	●	●	
				8	Metal bowl with level gauge	-	●	●	
				C	With bowl guard	●	-	-	
				6C	With bowl guard (Nylon bowl)	●	-	-	
e			Air filter and mist separator drain port	Nil	With drain cock	●	●	●	
				J	Drain guide 1/8	●	-	-	
				W	Drain cock with barb fitting	-	●	●	
f			Exhaust mechanism	Nil	Relieving type	●	●	●	
				N	Non-relieving type	●	●	●	
g			Flow direction	Nil	Flow direction: Left to right	●	●	●	
				R	Flow direction: Right to left	●	●	●	
h			Unit indication	Nil	Product: MPa, °C Pressure gauge: MPa	●	●	●	
				Z	Product: psi, °F Pressure gauge: psi (and MPa)	○ Note 2)	○ Note 2)	○ Note 2)	
				ZA	Digital pressure switch: With unit selection function	△ Note3)	△ Note3)	△ Note3)	

Note 1) ④Option and ⑤Semi-standard: Select one each for a to h.

Note 2) ○: For NPT thread type only.

Note 3) △: Select with an option E1, E2, E3 or E4.

5. Options

Refer to the operation manual of each product.

6. Structural Drawing and Replacement Part

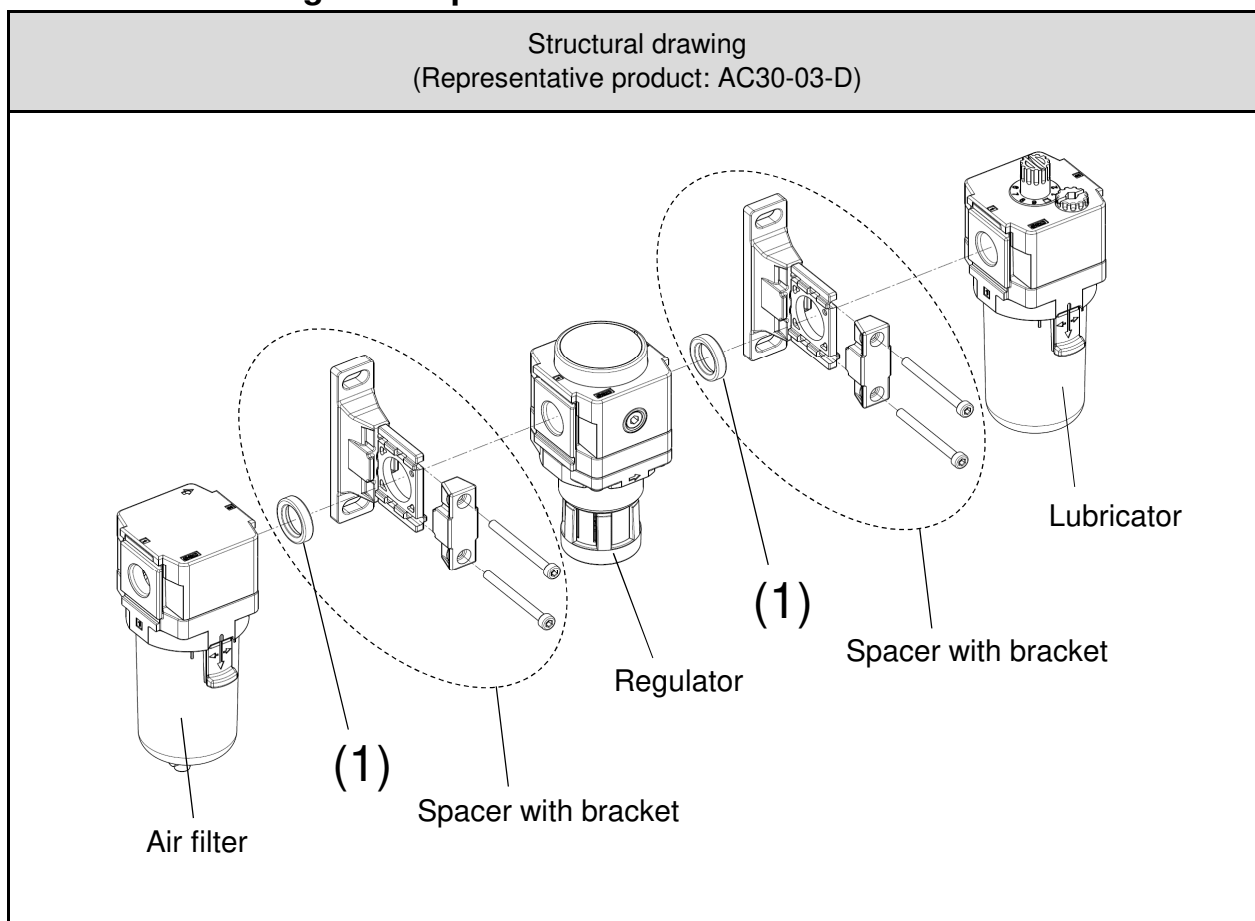

Replacement part

Component No.	Part name	Main material	Part No.				
			AC20(A,B,C,D)-D	AC30(A,B,C,D)-D	AC40(A,B,C,D)-D	AC40(A,B,C,D)-06-D	AC50(A,B)-D AC60(A,B)-D
(1)	Seal	HNBR	Y220P-050S	Y320P-050S	Y420P-050S	Y520P-050S	Y620P-050S

Note 1) The number in the table and structural drawing is consistent with the number in [8. How to Replace the Products] (P23) and [9. Disassembly Drawing] (P24).

Note 2) For individual product, refer to the operation manual or catalog of each product.

7. Troubleshooting

Refer to [8. How to Replace the Products] (P23) and [9. Disassembly Drawing] (P24).

Trouble		Possible cause	Countermeasure	Page for reference
Category	Failure			
Air leakage	Air leaks from the part where products are connected.	1. Seal is damaged.	Replace the seal with a new one.	P23
		2. Screws for retainer are loose.	Tighten screws to the specified torque.	P23

Note) For individual product, refer to the operation manual of each product.

8. How to Replace the Products

Warning

Before replacement, make sure that no pressure remains in the air combination.

Also, make sure to loosen the knob of the regulator or filter regulator so that the set pressure is zero.

After replacement, confirm that the product satisfies specific functions and no external leakage occurs before operating it.

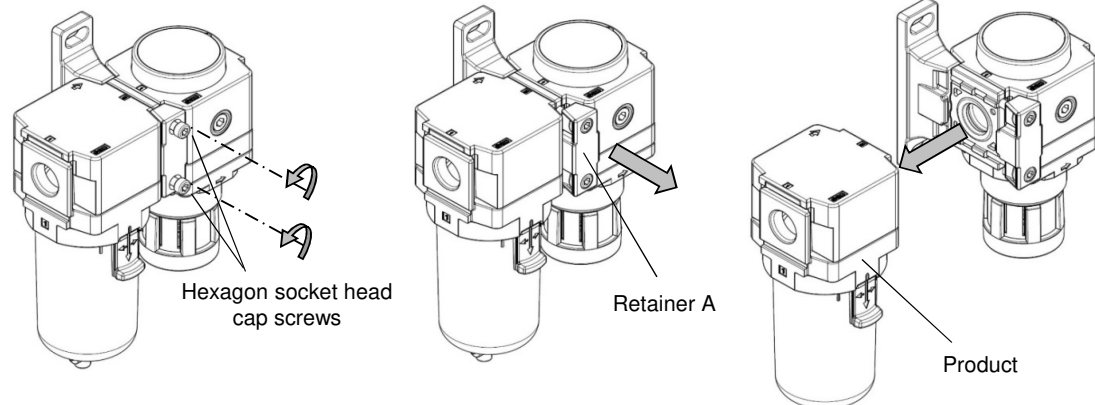
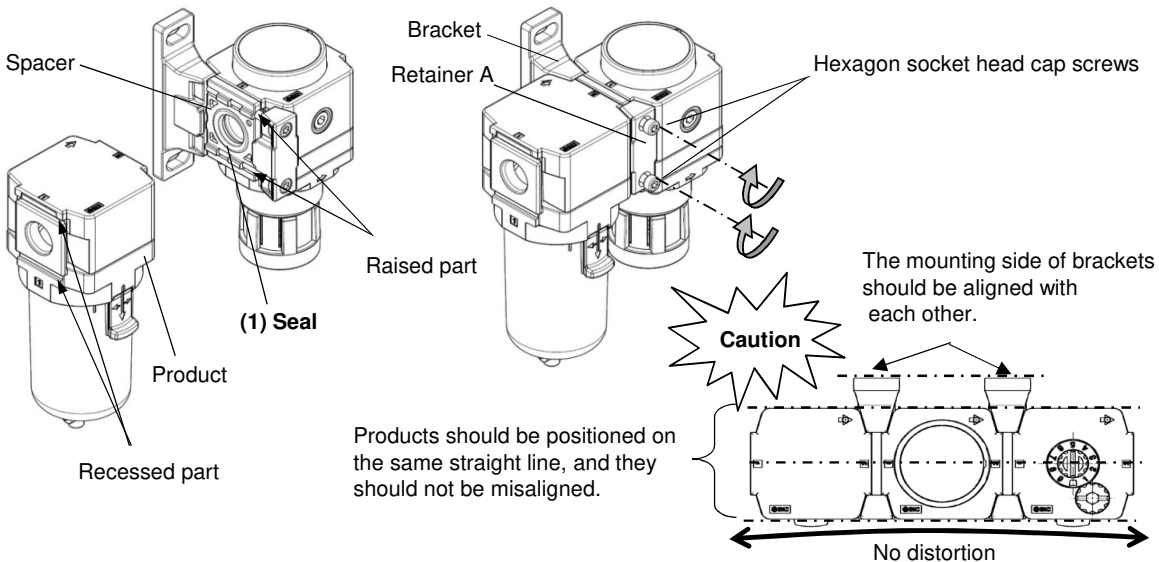
Applicable model	Work category	Procedure	Tool	Criteria
AC20 AC30 AC40 AC50 AC60	Disassembly	1) Untighten the two hexagon socket head cap screws with a hexagon wrench to loosen the retainer A.	Hexagon wrench Nominal size: AC20-D 2 AC30-D AC40-D 3 AC40-06-D AC50-D 4 AC60-D	-
		2) Remove the product.	-	-
 <p>Hexagon socket head cap screws</p> <p>Retainer A</p> <p>Product</p>				
	Work category	Procedure	Tool	Criteria
	Assembly	3) Fit the raised part of the spacer to the recessed part of the product.	-	-
		4) Tighten the retainer A with two hexagon socket head cap screws temporarily.	-	-
		5) Tighten those two hexagon socket head cap screws with a hexagon wrench evenly. Refer to the criteria shown on the right for the tightening torque for the screws.	Hexagon wrench Nominal size: AC20-D 2 AC30-D AC40-D 3 AC40-06-D AC50-D 4 AC60-D	Tightening torque: AC20-D 0.36+/-0.036 N m AC30-D AC40-D 1.2+/-0.05 N m AC40-06-D AC50-D 1.5+/-0.05 N m AC60-D 3.0+/-0.05 N m
 <p>Spacer</p> <p>Bracket</p> <p>Retainer A</p> <p>Hexagon socket head cap screws</p> <p>Raised part</p> <p>(1) Seal</p> <p>Product</p> <p>Recessed part</p> <p>Caution</p> <p>The mounting side of brackets should be aligned with each other.</p> <p>Products should be positioned on the same straight line, and they should not be misaligned.</p> <p>No distortion</p>				

Note) For individual product, refer to the operation manual of each product.

9. Disassembly Drawing

9-1. F.R.L. Combination

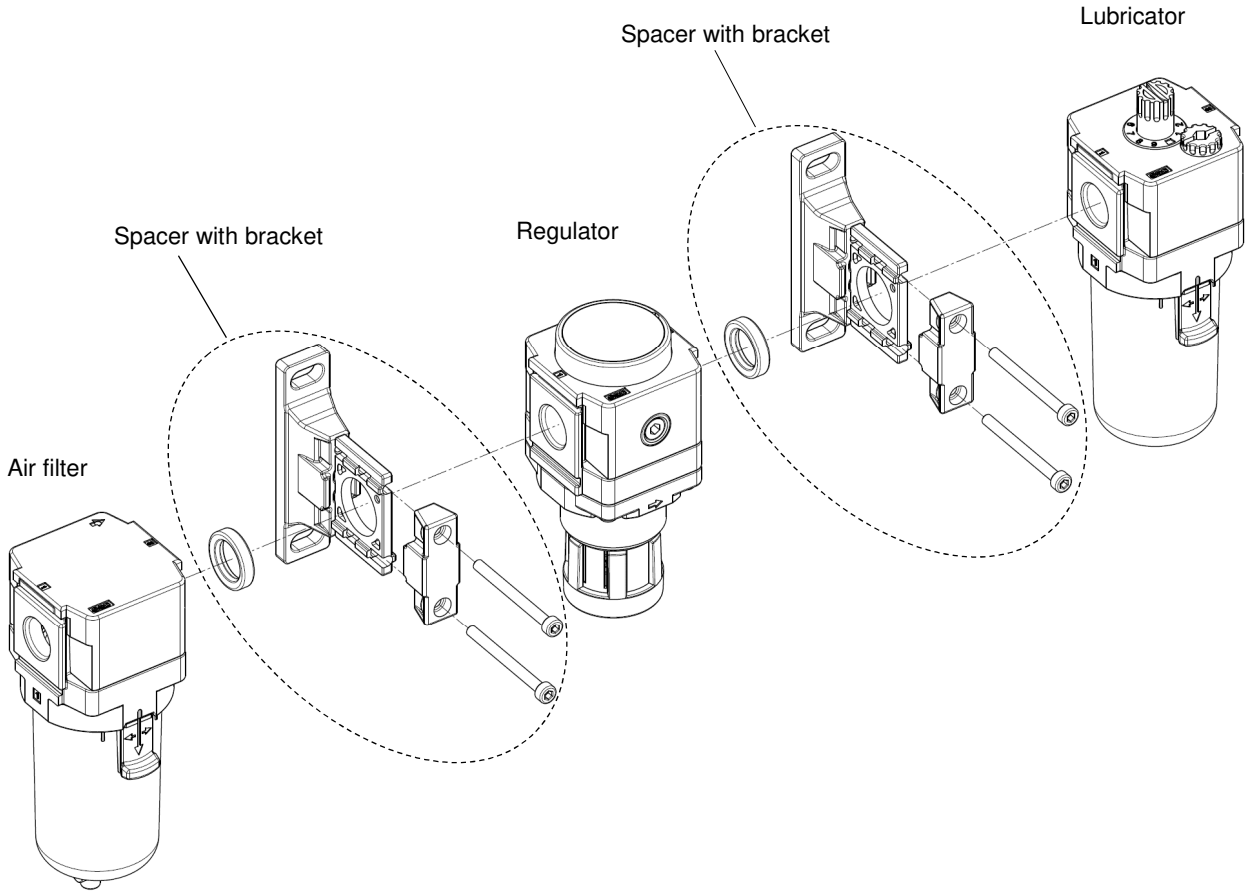

9-2. Spacer with bracket

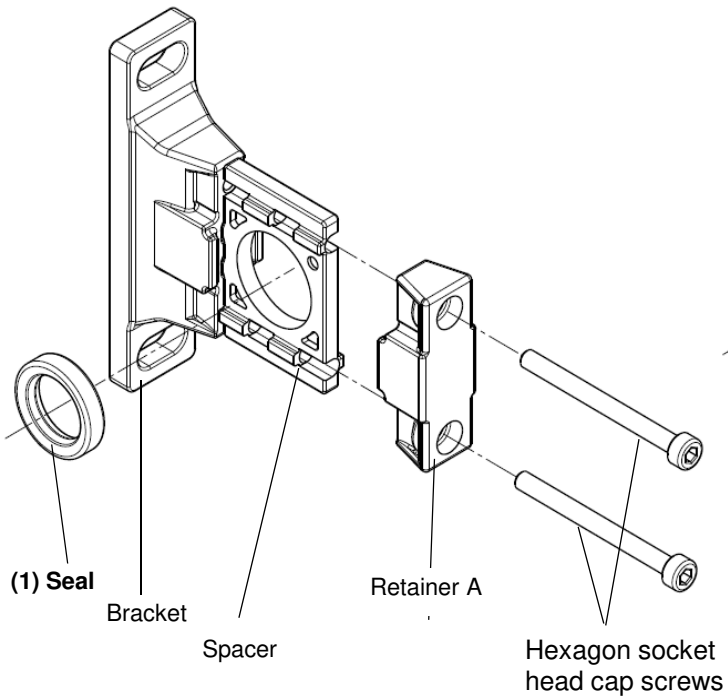

9-3. Spacer

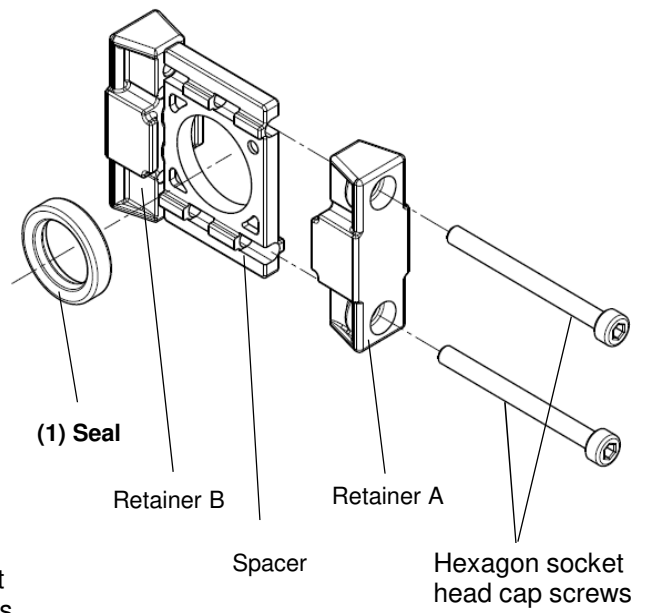

10. Dimensions

10-1. AC20-D to AC60-D

AC20-D

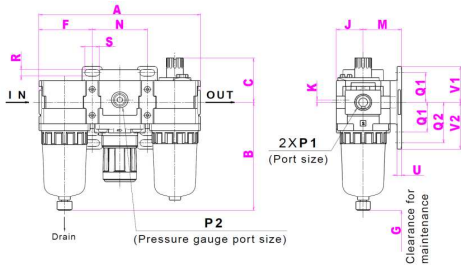

AC30-D

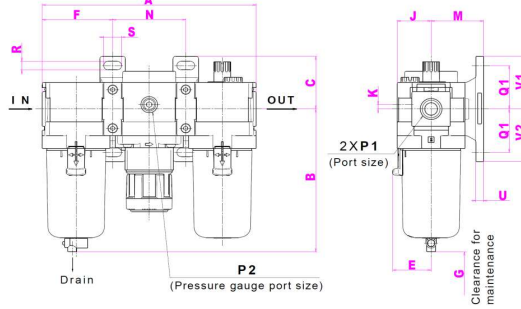

AC40-D to AC60-D

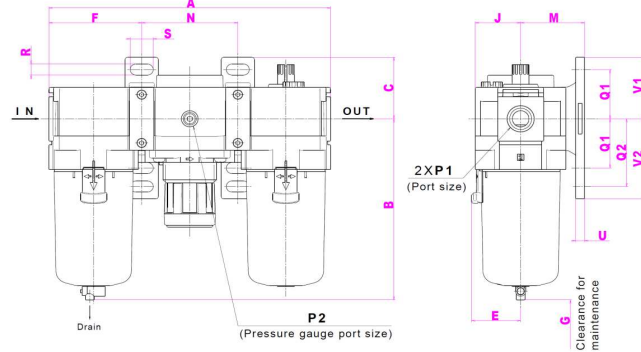

Applicable model	Optional specifications			
	Square embedded type pressure gauge	Digital pressure gauge	Round type pressure gauge	Round type pressure gauge (with color zone)
AC20-D to AC60-D				

Applicable model	Optional specifications	Semi-standard specifications					
	With auto drain	PC/PA bowl		Metal bowl		Metal bowl with level gauge	
		Drain cock with barb fitting	With drain guide	With drain guide	With drain guide	With drain guide	With drain guide
AC20-D							
AC30-D to AC60-D							

Model	Standard specifications													Bracket mount					
	P1	P2	A	B	C	E	F	G	J	K	M	N	Q1	Q2	R	S	U	V1	V2
AC20-D	1/8, 1/4	1/8	126.4	87.6	35.9	-	41.6	60	21	2	30	43.2	24	33	5.5	11.5	3.5	29	38
AC30-D	1/4, 3/8	1/8	167.4	115.4	38.1	30	55.1	80	26.5	3.5	41	57.2	35	-	7	14	6	42.5	42.5
AC40-D	1/4, 3/8, 1/2	1/8	220.4	147.1	44	38.4	72.6	110	35.5	0	50	75.2	40	55	9	18	7	50	65
AC40-06-D	3/4	1/8	235.4	149.1	44	38.4	77.6	110	35.5	0	50	80.2	40	55	9	18	7	50	65
AC50-D	3/4, 1	1/8	282.4	220.1	48	38.4	93.1	110	45	0	70	96.2	50	70	11	20	8	60	80
AC60-D	1	1/8	297.4	234.1	48	38.4	98.1	110	45	0	70	101.2	50	70	11	20	8	60	80

Model	Optional specifications										Semi-standard specifications						
	Square embedded type pressure gauge		Digital pressure switch		Round type pressure gauge		Round type pressure gauge (Semi-standard: Z)		Round type pressure gauge (With color zone)		With auto drain	PC/PA bowl		Metal bowl		Metal bowl with level gauge	
	H	J	H	J	H	J	H	J	H	J	B	With barb fitting	With drain guide	With drain cock	With drain guide	With drain cock	With drain guide
AC20-D	□28	27	□27.8	37.5	φ37.5	57.5	φ37.5	58.5	φ37.5	58.5	104.9	-	91.4	87.4	93.9	-	-
AC30-D	□28	32.5	□27.8	43	φ37.5	63	φ37.5	64	φ37.5	64	157.1	123.9	122.2	117.8	122.3	137.8	142.3
AC40-D	□28	41.5	□27.8	52	φ42.5	73	φ42.5	73	φ42.5	73	186.9	155.6	153.9	149.5	154	169.5	174
AC40-06-D	□28	41.5	□27.8	52	φ42.5	73	φ42.5	73	φ42.5	73	188.9	157.6	155.9	151.5	156	171.5	176
AC50-D	□28	51	□27.8	61.5	φ42.5	82.5	φ42.5	82.5	φ42.5	82.5	259.9	228.6	226.9	222.5	227	242.5	247
AC60-D	□28	51	□27.8	61.5	φ42.5	82.5	φ42.5	82.5	φ42.5	82.5	273.9	242.6	240.9	236.5	241	256.5	261

10-2. AC20A-D to AC60A-D

AC20A-D

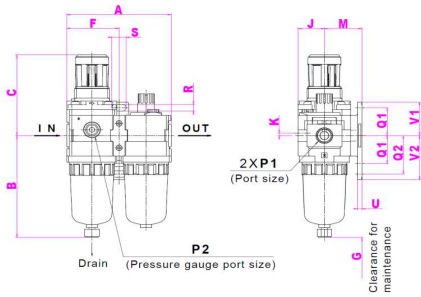

AC30A-D

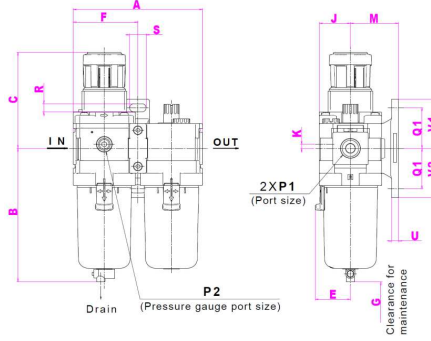

AC40A-D to AC60A-D

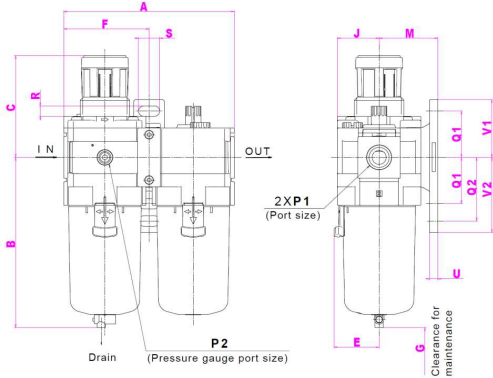

Applicable model	Optional specifications			
	Square embedded type pressure gauge	Digital pressure gauge	Round type pressure gauge	Round type pressure gauge (with color zone)
AC20A-D to AC60A-D				

Applicable model	Optional specifications	Semi-standard specifications				
		PC/PA bowl		Metal bowl		Metal bowl with level gauge
	With auto drain	Drain cock with barb fitting	With drain guide	With drain guide	With drain guide	With drain guide
AC20A-D						
AC30A-D to AC60A-D						

Model	Standard specifications																	
	P1	P2	A	B	C ^{Note}	E	F	G	J	K	Bracket mount							
											M	Q1	Q2	R	S	U	V1	V2
AC20A-D	1/8, 1/4	1/8	83.2	87.6	71.8	-	41.6	60	21	5	30	24	33	5.5	11.5	3.5	29	38
AC30A-D	1/4, 3/8	1/8	110.2	115.3	86.5	30	55.1	80	26.5	3.5	41	35	-	7	14	6	42.5	42.5
AC40A-D	1/4, 3/8, 1/2	1/8	145.2	147.1	91.5	38.4	72.6	110	35.5	0	50	40	55	9	18	7	50	65
AC40A-06-D	3/4	1/8	155.2	149.1	93	38.4	77.6	110	35.5	0	50	40	55	9	18	7	50	65
AC50A-D	3/4, 1	1/8	191.2	234.1	155	38.4	98.1	110	45	0	70	50	70	11	20	8	60	80
AC60A-D	1	1/8	196.2	234.1	155	38.4	98.1	110	45	0	70	50	70	11	20	8	60	80

Model	Options										Semi-standard specification						
	Square embedded type pressure gauge		Digital pressure switch		Round type pressure gauge		Round type pressure gauge (Semi-standard: Z)		Round type pressure gauge (With color zone)		With auto drain	PC/PA bowl		Metal bowl		Metal bowl with level gauge	
	H	J	H	J	H	J	H	J	H	J	B	With barb fitting	With drain guide	With drain cock	With drain guide	With drain cock	With drain guide
AC20A-D	□28	27	□27.8	37.5	φ37.5	57.5	φ37.5	58.5	φ37.5	58.5	104.9	-	91.4	87.4	93.9	-	-
AC30A-D	□28	32.5	□27.8	43	φ37.5	63	φ37.5	64	φ37.5	64	157.1	123.9	122.2	118	122	138	142
AC40A-D	□28	41.5	□27.8	52	φ42.5	73	φ42.5	73	φ42.5	73	186.9	155.6	153.9	150	154	170	174
AC40A-06-D	□28	41.5	□27.8	52	φ42.5	73	φ42.5	73	φ42.5	73	188.9	157.6	155.9	151.5	156	171.5	176
AC50A-D	□28	51	□27.8	61.5	φ42.5	82.5	φ42.5	82.5	φ42.5	82.5	259.9	242.6	240.9	236.5	241	256.5	261
AC60A-D	□28	51	□27.8	61.5	φ42.5	82.5	φ42.5	82.5	φ42.5	82.5	273.9	242.6	240.9	236.5	241	256.5	261

Note) Dimension C shows the distance when the filter regulator knob is unlocked.

10-3. AC20B-D to AC60B-D

AC20B-D

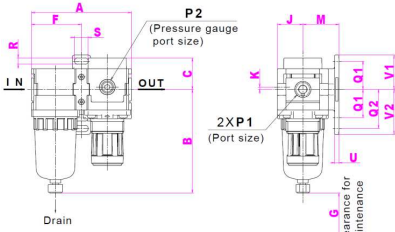

AC30B-D

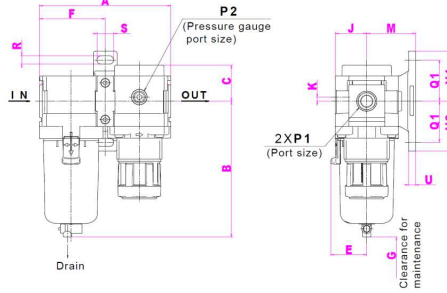

AC40B-D to AC60B-D

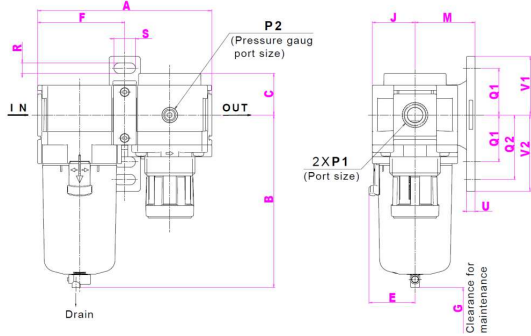

Applicable model	Optional specifications			
	Square embedded type pressure gauge	Digital pressure gauge	Round type pressure gauge	Round type pressure gauge (with color zone)
AC20B-D to AC60B-D				

Applicable model	Optional specifications	Semi-standard specifications					
	With auto drain	PC/PA bowl		Metal bowl		Metal bowl with level gauge	
		Drain cock with barb fitting	With drain guide		With drain guide		With drain guide
AC20B-D							
AC30B-D to AC60B-D	N.O.: Black N.C.: Gray Thread type/Rc: G φ10 One-touch fitting Thread type/NPT: φ3/8" One-touch fitting						

Model	Standard specifications																	
	P1	P2	A	B	C	E	F	G	J	K	Bracket mount							
											M	Q1	Q2	R	S	U	V1	V2
AC20B-D	1/8, 1/4	1/8	83.2	87.6	26.5	-	41.6	25	21	2	30	24	33	5.5	11.5	3.5	29	38
AC30B-D	1/4, 3/8	1/8	110.2	115.4	30.5	30	55.1	35	26.5	3.5	41	35	-	7	14	6	42.5	42.5
AC40B-D	1/4, 3/8, 1/2	1/8	145.2	147.1	35.5	38.4	72.6	40	35.5	0	50	40	55	9	18	7	50	65
AC40B-06-D	3/4	1/8	155.2	149.1	35.5	38.4	77.6	40	35.5	0	50	40	55	9	18	7	50	65
AC50B-D	3/4, 1	1/8	186.2	220.1	43	38.4	93.1	30	45	0	70	50	70	11	20	8	60	80
AC60B-D	1	1/8	196.2	234.1	45	38.4	98.1	30	45	0	70	50	70	11	20	8	60	80

Model	Options										Semi-standard specifications						
	Square embedded type pressure gauge		Digital pressure switch	Round type pressure gauge		Round type pressure gauge (Semi-standard: Z)		Round type pressure gauge (With color zone)		With auto drain	PC/PA bowl		Metal bowl		Metal bowl with level gauge		
	H	J	H	J	H	J	H	J	H	J	B	With barb fitting	With drain guide	With drain cock	With drain guide	With drain cock	With drain guide
AC20B-D	□28	27	□27.8	37.5	φ37.5	57.5	φ37.5	58.5	φ37.5	58.5	104.9	-	91.4	87.4	93.9	-	-
AC30B-D	□28	32.5	□27.8	43	φ37.5	63	φ37.5	64	φ37.5	64	157.1	123.9	122.2	118	122	138	142
AC40B-D	□28	41.5	□27.8	52	φ42.5	73	φ42.5	73	φ42.5	73	186.9	155.6	153.9	150	154	170	174
AC40B-06-D	□28	41.5	□27.8	52	φ42.5	73	φ42.5	73	φ42.5	73	188.9	157.6	155.9	151.5	156	171.5	176
AC50B-D	□28	51	□27.8	61.5	φ42.5	82.5	φ42.5	82.5	φ42.5	82.5	259.9	228.6	226.9	222.5	227	242.5	247
AC60B-D	□28	51	□27.8	61.5	φ42.5	82.5	φ42.5	82.5	φ42.5	82.5	273.9	242.6	240.9	236.5	241	256.5	261

10-4. AC20C-D to AC40C-D

AC20C-D

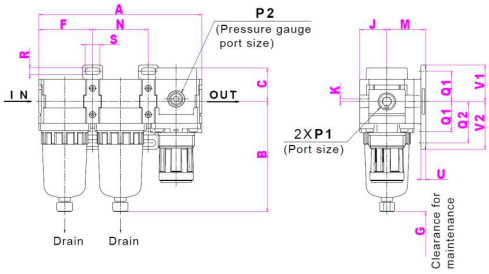

AC30C-D

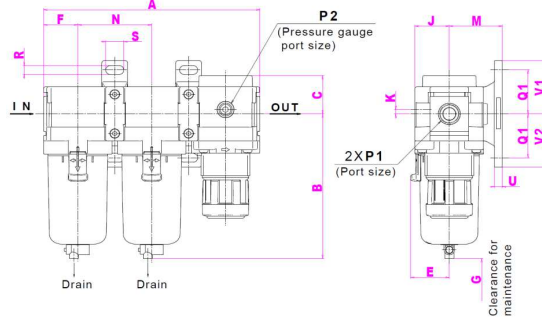

AC40C-D

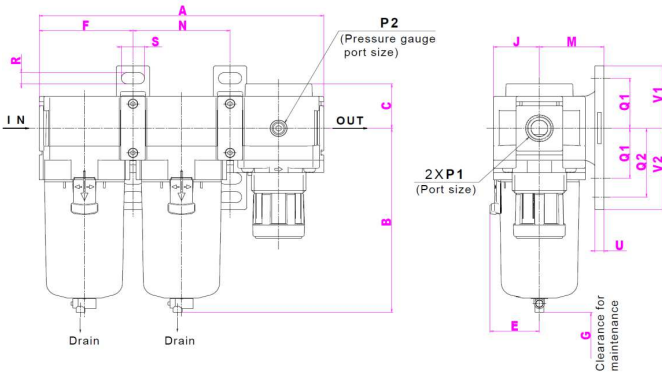

Applicable model	Optional specifications			
	Square embedded type pressure gauge	Digital pressure gauge	Round type pressure gauge	Round type pressure gauge (with color zone)
AC20C-D to AC40C-D				

Applicable model	Optional specifications	Semi-standard specifications					
	With auto drain	PC/PA bowl		Metal bowl		Metal bowl with level gauge	
		Drain cock with barb fitting	With drain guide		With drain guide		With drain guide
AC20C-D							
AC30C-D to AC40C-D	 N.O.: Black N.C.: Gray Thread type/Rc: G φ10 One-touch fitting Thread type/NPT: φ3/8" One-touch fitting	 Barb fitting applicable tubing: T0604					

Model	Standard specifications																		
	P1	P2	A	B	C	E	F	G	J	K	Bracket mount								
											M	N	Q1	Q2	R	S	U	V1	V2
AC20C-D	1/8, 1/4	1/8	126.4	87.6	26.5	-	41.6	40	21	2	30	43.2	24	33	5.5	11.5	3.5	29	38
AC30C-D	1/4, 3/8	1/8	167.4	115.4	30.5	30	55.1	50	26.5	3.5	41	57.2	35	-	7	14	6	42.5	42.5
AC40C-D	1/4, 3/8, 1/2	1/8	220.4	147.1	35.5	38.4	72.6	75	35.5	0	50	75.2	40	55	9	18	7	50	65
AC40C-06-D	3/4	1/8	235.4	149.1	35.5	38.4	77.6	75	35.5	0	50	80.2	40	55	9	18	7	50	65

Model	Options										Semi-standard specifications						
	Square embedded type pressure gauge		Digital pressure switch		Round type pressure gauge		Round type pressure gauge (Semi-standard: Z)		Round type pressure gauge (With color zone)		With auto drain	PC/PA bowl		Metal bowl		Metal bowl with level gauge	
	H	J	H	J	H	J	H	J	H	J	B	With barb fitting	With drain guide	With drain cock	With drain guide	With drain cock	With drain guide
AC20C-D	□28	27	□27.8	37.5	φ37.5	57.5	φ37.5	58.5	φ37.5	58.5	104.9	-	91.4	87.4	93.9	-	-
AC30C-D	□28	32.5	□27.8	43	φ37.5	63	φ37.5	64	φ37.5	64	157.1	123.9	122.2	117.8	122.3	137.8	142.3
AC40C-D	□28	41.5	□27.8	52	φ42.5	73	φ42.5	73	φ42.5	73	186.9	155.6	153.9	149.5	154	169.5	174
AC40C-06-D	□28	41.5	□27.8	52	φ42.5	73	φ42.5	73	φ42.5	73	188.9	157.6	155.9	151.5	156	171.5	176

10-5. AC20D-D to AC40D-D

AC20D-D

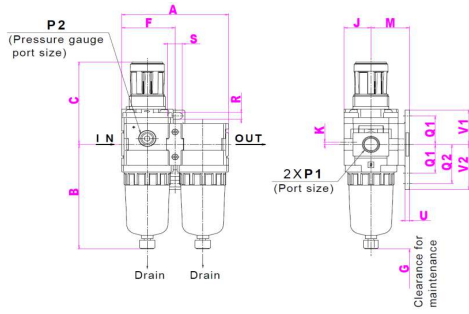

AC30D-D

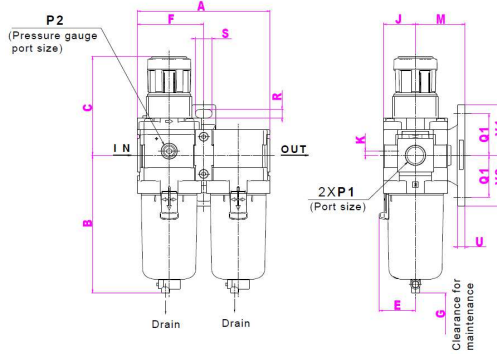

AC40D-D

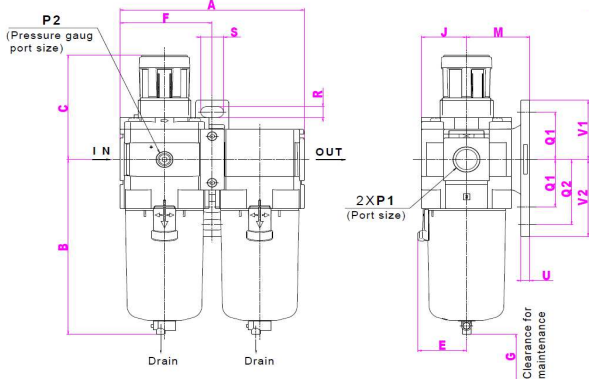

Applicable model	Optional specifications			
	Square embedded type pressure gauge	Digital pressure gauge	Round type pressure gauge	Round type pressure gauge (with color zone)
AC20D-D to AC40D-D				

Applicable model	Optional specifications	Semi-standard specifications				
		PC/PA bowl		Metal bowl		Metal bowl with level gauge
	With auto drain	Drain cock with barb fitting	With drain guide	With drain guide	With drain guide	With drain guide
AC20D-D						
AC30D-D to AC40D-D						

Model	Standard specifications																	
	P1	P2	A	B	C ^{Note)}	E	F	G	J	K	Bracket mount							
											M	Q1	Q2	R	S	U	V1	V2
AC20D-D	1/8, 1/4	1/8	83.2	87.6	71.8	-	41.6	40	21	5	30	24	33	5.5	11.5	3.5	29	38
AC30D-D	1/4, 3/8	1/8	110.2	115.3	86.5	30	55.1	55	26.5	3.5	41	35	-	7	14	6	42.5	42.5
AC40D-D	1/4, 3/8, 1/2	1/8	145.2	147.1	91.5	38.4	72.6	80	35.5	0	50	40	55	9	18	7	50	65
AC40D-06-D	3/4	1/8	155.2	149.1	93	38.4	77.6	80	35.5	0	50	40	55	9	18	7	50	65

Model	Options										Semi-standard specifications						
	Square embedded type pressure gauge		Digital pressure switch		Round type pressure gauge		Round type pressure gauge (Semi-standard: Z)		Round type pressure gauge (With color zone)		With auto drain	PC/PA bowl		Metal bowl		Metal bowl with level gauge	
	H	J	H	J	H	J	H	J	H	J	B	With barb fitting	With drain guide	With drain cock	With drain guide	With drain cock	With drain guide
AC20D-D	□28	27	□27.8	37.5	φ37.5	57.5	φ37.5	58.5	φ37.5	58.5	104.9	-	91.4	87.4	93.9	-	-
AC30D-D	□28	32.5	□27.8	43	φ37.5	63	φ37.5	64	φ37.5	64	157.1	123.9	122.2	117.8	122.3	137.8	142.3
AC40D-D	□28	41.5	□27.8	52	φ42.5	73	φ42.5	73	φ42.5	73	186.9	155.6	153.9	149.5	154	169.5	174
AC40D-06-D	□28	41.5	□27.8	52	φ42.5	73	φ42.5	73	φ42.5	73	188.9	157.6	155.9	151.5	156	171.5	176

Note) Dimension C shows the distance when the filter regulator knob is unlocked.

Revision history

A	Corrected.	Nov.2019.
B	Corrected.	Feb.2020.
C	40-06,50,60 size added.	Nov.2020.

SMC Corporation

4-14-1, Sotokanda, Chiyoda-ku, Tokyo 101-0021 JAPAN

Tel: + 81 3 5207 8249 Fax: +81 3 5298 5362

URL <https://www.smcworld.com>

Note: Specifications are subject to change without prior notice and any obligation on the part of the manufacturer.
© 2019 SMC Corporation All Rights Reserved