



Operation Manual

PRODUCT NAME

Micro Mist Separator

MODEL / Series / Product Number

AMD30-(F,N)02~(F,N)03(B,C,D)(-2,6,8,J,R,W,Z)-D

SMC Corporation

Contents

	Page
1. Safety Instructions	2 to 7
2. Application	8
3. Standard specifications	8
4. How to order	9
5. Construction / Options / Replacement parts	10
6. Bowl assembly specifications	11 to 13
7. Assembly of Optional parts	14
8. Operation and Adjustment	15 to 16
9. Troubleshooting	17
10. Replacement work procedure	18 to 21
1) Element assembly	18 to 19
2) Bowl assembly	20 to 21
11. Exploded Drawing	22
12. Dimensions	23



Micro Misto Separator Safety Instructions

These safety instructions are intended to prevent hazardous situations and/or equipment damage. These instructions indicate the level of potential hazard with the labels of "Caution," "Warning" or "Danger." They are all important notes for safety and must be followed in addition to International Standards (ISO/IEC)*1), and other safety regulations.

*1) ISO 4414: Pneumatic fluid power -- General rules relating to systems.

ISO 4413: Hydraulic fluid power -- General rules relating to systems.

IEC 60204-1: Safety of machinery -- Electrical equipment of machines .(Part 1: General requirements)

ISO 10218: Manipulating industrial robots -Safety.

etc.



Caution

Caution indicates a hazard with a low level of risk which, if not avoided, could result in minor or moderate injury.



Warning

Warning indicates a hazard with a medium level of risk which, if not avoided, could result in death or serious injury.



Danger

Danger indicates a hazard with a high level of risk which, if not avoided, will result in death or serious injury.

Warning

1. The compatibility of the product is the responsibility of the person who designs the equipment or decides its specifications.

Since the product specified here is used under various operating conditions, its compatibility with specific equipment must be decided by the person who designs the equipment or decides its specifications based on necessary analysis and test results.

The expected performance and safety assurance of the equipment will be the responsibility of the person who has determined its compatibility with the product.

This person should also continuously review all specifications of the product referring to its latest catalog information, with a view to giving due consideration to any possibility of equipment failure when configuring the equipment.

2. Only personnel with appropriate training should operate machinery and equipment.

The product specified here may become unsafe if handled incorrectly.

The assembly, operation and maintenance of machines or equipment including our products must be performed by an operator who is appropriately trained and experienced.

3. Do not service or attempt to remove product and machinery/equipment until safety is confirmed.

1. The inspection and maintenance of machinery/equipment should only be performed after measures to prevent falling or runaway of the driven objects have been confirmed.

2. When the product is to be removed, confirm that the safety measures as mentioned above are implemented and the power from any appropriate source is cut, and read and understand the specific product precautions of all relevant products carefully.

3. Before machinery/equipment is restarted, take measures to prevent unexpected operation and malfunction.

4. Contact SMC beforehand and take special consideration of safety measures if the product is to be used in any of the following conditions.

1. Conditions and environments outside of the given specifications, or use outdoors or in a place exposed to direct sunlight.

2. Installation on equipment in conjunction with atomic energy, railways, air navigation, space, shipping, vehicles, military, medical treatment, combustion and recreation, or equipment in contact with food and beverages, emergency stop circuits, clutch and brake circuits in press applications, safety equipment or other applications unsuitable for the standard specifications described in the product catalog.

3. An application which could have negative effects on people, property, or animals requiring special safety analysis.

4. Use in an interlock circuit, which requires the provision of double interlock for possible failure by using a mechanical protective function, and periodical checks to confirm proper operation.



Micro Misto Separator Safety Instructions

Caution

The product is provided for use in manufacturing industries.

The product herein described is basically provided for peaceful use in manufacturing industries. If considering using the product in other industries, consult SMC beforehand and exchange specifications or a contract if necessary.
If anything is unclear, contact your nearest sales branch.

Limited warranty and Disclaimer/Compliance Requirements

The product used is subject to the following "Limited warranty and Disclaimer" and "Compliance Requirements".

Read and accept them before using the product.

Limited warranty and Disclaimer

1. The warranty period of the product is 1 year in service or 1.5 years after the product is delivered, whichever is first. *2)

Also, the product may have specified durability, running distance or replacement parts. Please consult your nearest sales branch.

2. For any failure or damage reported within the warranty period which is clearly our responsibility, a replacement product or necessary parts will be provided.

This limited warranty applies only to our product independently, and not to any other damage incurred due to the failure of the product.

3. Prior to using SMC products, please read and understand the warranty terms and disclaimers noted in the specified catalog for the particular products.

*2) Vacuum pads are excluded from this 1 year warranty.

A vacuum pad is a consumable part, so it is warranted for a year after it is delivered.

Also, even within the warranty period, the wear of a product due to the use of the vacuum pad or failure due to the deterioration of rubber material are not covered by the limited warranty.

Compliance Requirements

1. The use of SMC products with production equipment for the manufacture of weapons of mass destruction (WMD) or any other weapon is strictly prohibited.

2. The exports of SMC products or technology from one country to another are governed by the relevant security laws and regulation of the countries involved in the transaction. Prior to the shipment of a SMC product to another country, assure that all local rules governing that export are known and followed.

Caution

SMC products are not intended for use as instruments for legal metrology.

Measurement instruments that SMC manufactures or sells have not been qualified by type approval tests relevant to the metrology (measurement) laws of each country.

Therefore, SMC products cannot be used for business or certification ordained by the metrology (measurement) laws of each country.

Design

Warning

- 1) Consult SMC if no leakage is allowed due to the environment, or if the operating fluid is not air.
- 2) Polycarbonate resin is used for the external parts including the bowl. Organic solvents including synthetic fluid, chemicals including acetone, alcohol, ethylene chloride, sulphuric acid, nitrate, hydrochloric acid, cutting oil, kerosene, gasoline, lock material of screw are harmful. Do not use the product where these are present. Suitability of organic solvents, chemical atmospheres and chemicals in contact with resin parts. (reference)

Type	Chemical name	Application examples	Material	
			Polycarbonate	Nylon
Acid	Hydrochloric acid Sulfuric acid, Phosphoric acid Chromic acid	Acid washing liquid for metals	△	×
Alkaline	Sodium hydroxide (Caustic soda) Potash Calcium hydroxide (Slack lime) Ammonia water Carbonate of soda	Degreasing of metals Industrial salts Water-soluble cutting	×	○
Inorganic salts	Sodium sulfide Sulfate of potash Sulfate of soda	—	×	△
Chlorine solvents	Carbon tetrachloride Chloroform Ethylene chloride Methylene chloride	Cleansing liquid for metals Printing ink Dilution	×	△
Aromatic series	Benzene Toluene Paint thinner	Coatings Dry cleaning	×	△
Ketone	Acetone Methyl ethyl ketone Cyclohexane	Photographic film Dry cleaning Textile industries	×	×
Alcohol	Ethyl alcohol IPA Methyl alcohol	Antifreeze Adhesives	△	×
Oil	Gasoline Kerosene	—	×	○
Ester	Phthalic acid dimethyl Phthalic acid diethyl Acetic acid	Synthetic oil Anti-rust additives	×	○
Ether	Methyl ether Ethyl ether	Brake oil additives	×	○
Amino	Methyl amino	Cutting oil Brake oil additives Rubber accelerator	×	×
Others	Thread-lock fluid Seawater Leak tester	—	×	△

○: Essentially safe △: Some effects may occur ×: Effects will occur

When the above factors are present, or there is some doubt, use a metal bowl for safety.

- 3) Avoid the application where charge and discharge of pressure to the resin bowl is switched frequently. This may damage the bowl. A metal bowl is recommended in these cases.
- 4) Protect from ultra violet ray and radiation heat by shield.

- 5) Applications in which the difference between the inlet and outlet pressure exceeds 0.1MPa must be avoided. Or the element is broken.
- 6) For air blow applications, prevent airborne particles from the operating environment entering into the compressed air stream, or foreign matter may adhere to the workpiece during the air blow.
- 7) If the air equipment is mounted on the outlet of the product, particles will be generated from the equipment and required cleanliness may not be obtained. Instead, install the air equipment at the inlet.
- 8) Do not install the product in an environment subjected to vibration and impact. This may lead to breakage or malfunction.
- 9) Do not use the product in an environment subjected to sea water, water or (water) vapour. This may damage the bowl.

Selection

Warning

- 1) Grease is used on the internal sliding parts and seals. The grease may flow to the outlet side. Please contact SMC if this is a problem. If this is not acceptable, contact SMC.
- 2) Select the model so that the maximum discharge value (instantaneous) of the flow rate will not exceed the rated air capacity.
- 3) N.O. type auto drain should be used under the following requirements to avoid operating failure. Output of compressor: 0.75kW or more. Discharged flow rate: 100 L/min (ANR) or more. If multiple auto drains are used, confirm used compressor has capacity over the result of multiplying the above capacity and the number of used auto drains. { For example, in case of two auto drain, the compressor need the capacity over 1.5kW [200 L/min (ANR)]. } Set pressure more than 0.1 MPa.
- 4) N.C. type auto drain should be used under the following requirements to avoid operating failure. Operating pressure for AD37-A is 0.15MPa or more.

Mounting

Warning

- 1) Do not drop or apply impact during transportation or installation. It will cause damage to the product or operation failure.
- 2) Do not install in areas of high humidity or high temperature. Operation outside of the product specification range may cause damage to the product or operation failure, or shorten the product life.
- 3) Connect the product ensuring the direction of "1"(IN) and "2"(OUT) for air direction or an arrow. Incorrect connections may cause malfunction.
- 4) Install with adequate space for maintenance beneath the product. Refer to the Dimensions section of each part for necessary space.
- 5) Install vertically so that outlet of drain would turned downward. Use with the outlet of drain turned horizontal or upward causes malfunction.

Piping

Warning

- 1) Before piping, perform flushing or cleaning of the piping, etc. to remove any cutting chips, cutting oil, solid foreign matter, etc. from the piping. Contamination of piping may cause damage or malfunction.
- 2) When installing piping, avoid chips and sealing materials from piping screws entering the inside of equipment. Or malfunction may occur. Also, if sealant tape is used, leave 1.5 to 2 thread ridges exposed at the end of the threads.

- 3) Connect piping/fittings using the recommended torque while holding the female thread side tightly. Insufficient tightening torque can cause loose piping or sealing failure. Over tightening may break the screw. If the female side is not held while tightening, excessive force will be applied to the bracket directly, causing breakage.

Recommended tightening torque		Unit: N · m		
Connection thread	1/8	1/4	3/8	1/2
Torque	7 to 9	12 to 14	22 to 24	28 to 30

- 4) When a SMC one-touch fitting is used, refer to the operation manual for the one-touch fitting.
- 5) Do not apply torsion or bending moment other than the weight of the product itself. External piping needs to be supported separately. Hard piping like steel tube is susceptible to excessive moment load or vibration. Insert the flexible tube to cancel the influence.
- 6) Drain guide is not equipped with valve function. Be sure to connect piping for drain. No piping for drain allows the drain and compressed air to exhaust freely. Also, the piping should be performed with drain guide held by spanner to prevent breakage of bowl. Otherwise, the bowl might be broken.
- 7) The piping for drain from auto drain should be connected under the following requirements to avoid operating failure. Tube I.D. $\phi 4$ ($\phi 3/16$ ") or larger for AD37, $\phi 6.5$ ($\phi 1/4$ ") or larger for AD38. Length: 5m (200 inch) or less.
- 8) Pipework for auto drain discharge which is higher than the auto drain outlet should be avoided. It may cause the the auto drain operation to fail.

Air Supply



Warning

- 1) Use clean air. Compressed air containing chemicals, organic solvent, synthetic oil or corrosive gas may lead to cause breakage of parts or malfunction.
- 2) Air containing too much moisture may deteriorate the performance. Install the refrigerated air dryer or aftercooler before the product.
- 3) Make sure that the operating pressure is not below the minimum operating pressure. If it is used at the minimum operating pressure or less, pressure resistance increase, leading to the decrease of operation or operation failure.



Caution

- 1) Install the mist separator AFM series or AM series as a pre-filter to the inlet of the product in order to avoid the clogging of early stage.

Maintenance



Warning

- 1) Release the pressure in the product to the atmosphere before replacing parts or removing piping.
- 2) Maintenance and checks should be done by following the procedure in the operation manual. Incorrect handling of the product may cause breakage or malfunction of the equipment or device.
- 3) Do not touch the product when operating at high temperature (40 to 60°C). The operators may get burnt. Be sure to confirm that the temperature of the container or operating part is reduced to 40 degrees or less to prevent burns.
- 4) Perform periodical check to find cracks, flaws or other deterioration on resin bowl. If any of them is seen, as malfunction is caused, replace with new bowl or metal bowl. Investigate and/or review the operating conditions if necessary.

- 5) Check for dirt in resin bowl periodically. If any dirt is seen, replace with new bowl. And if removing off the dirt by washing instead of using a replacement, never use washing material other than neutral detergent. Otherwise, the bowl is damaged.
- 6) Open and close drain cock by hand. The use of tools can result in damage to the product.
- 7) The element should be replaced within 2 years from start of use, when the pressure drop (difference between the inlet pressure and outlet pressure) reaches 0.1 MPa or if the element is broken.
- 8) Check the bowl regularly. Discharge it before it reaches the element. Refer to section 8. Operation and Adjustment (P15 to P16) for discharging of drain. When a resin bowl or a bowl with level gauge is used, discharge the drain before the drain reaches the MAX. DRAIN LEVEL.



Caution

- 1) Check the element periodically and replace it with a new one if necessary. If it is found that outlet pressure drops or the flow is restricted, check the condition of the element.
- 2) For the N.O. type auto drain, when there is no pressure, condensate which does not operate the auto drain mechanism will remain in the bowl. It is recommended to release the residual condensate manually at the end of the working day.

2. Application

This product aims at eliminating oil mist and solid foreign matter in the air line.

3. Standard specifications

Model	AMD30
Port size	1/4, 3/8
Fluid	Air
Ambient and fluid temperatures	-5 to 60°C (With no freezing)
Proof pressure	1.5MPa
Maximum operating pressure	1.0MPa
Minimum operating pressure	0.05MPa
Nominal filtration rating ^{Note1)}	0.01µm (Filtration efficiency:99.9%)
Outlet side oil mist concentration ^{Note2)}	Max. 0.1mg/m ³ (ANR)
Rated flow ^{Note3)}	750L/min(ANR)
Drainage capacity	25cm ³
Bowl material	Polycarbonate
Bowl guard	Polycarbonate
Weight	0.39kg

Note 1) Filtration efficiency for conditions below in addition to the rated conditions above
[Test condition ISO12500-3:2009 compliant].

Condition 1: The amount of process air, inlet pressure, and concentration of particles of the product inlet side are stable.

Condition 2: New element

Note 2) Outlet side oil mist concentration for conditions below in addition to the Rated condition above
[ISO12500-1:2007 compliant]

Condition 1: Outlet side oil mist concentration at the inlet = 1mg/m³(ANR)

Condition 2: Inlet temperature 25°C

Condition 3: Flow capacity, inlet pressure, inlet temperature, and the Inlet side oil mist concentration at the product inlet are stable.

Condition 4: New element

Note 3) Input pressure 0.7 MPa;

4. How to order

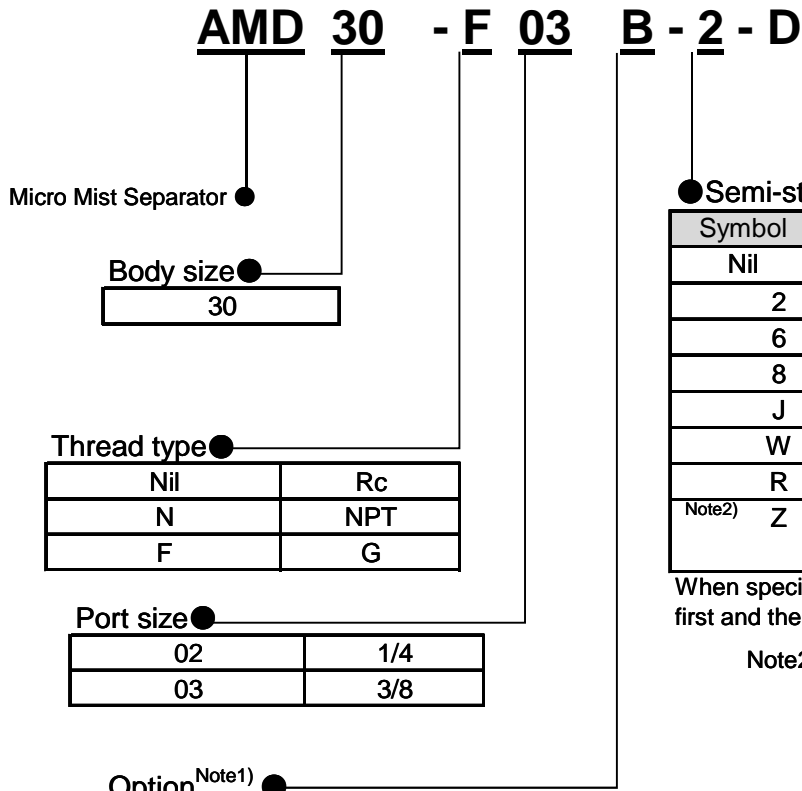

Body size	30
-----------	----

Thread type	
Nil	Rc
N	NPT
F	G

Port size	
02	1/4
03	3/8

● Semi-standard specification

Symbol	Contents
Nil	Polycarbonate bowl
2	Metal bowl
6	Nylon bowl
8	Metal bowl with level gauge
J	With drain guide
W	With drain cock/ Barb fitting
R	Right to left
^{Note2)} Z	Name plate : psi, °F Caution plate for bowl : psi, °F

When specifying more than one option, indicate the number first and then symbols alphabetically.

Note2) Available only for screw type NPT.

This product will not be sold for use in Japan.

Symbol	Contents
Nil	—
B	With bracket
C	Float type auto drain (N.C.)
D	Float type auto drain (N.O.)

When specifying more than one option, indicate the number first and then symbols alphabetically.

Note1) Option in packaged together, but not assembled .
(Note: for B only)

5. Construction / Options / Replacement parts

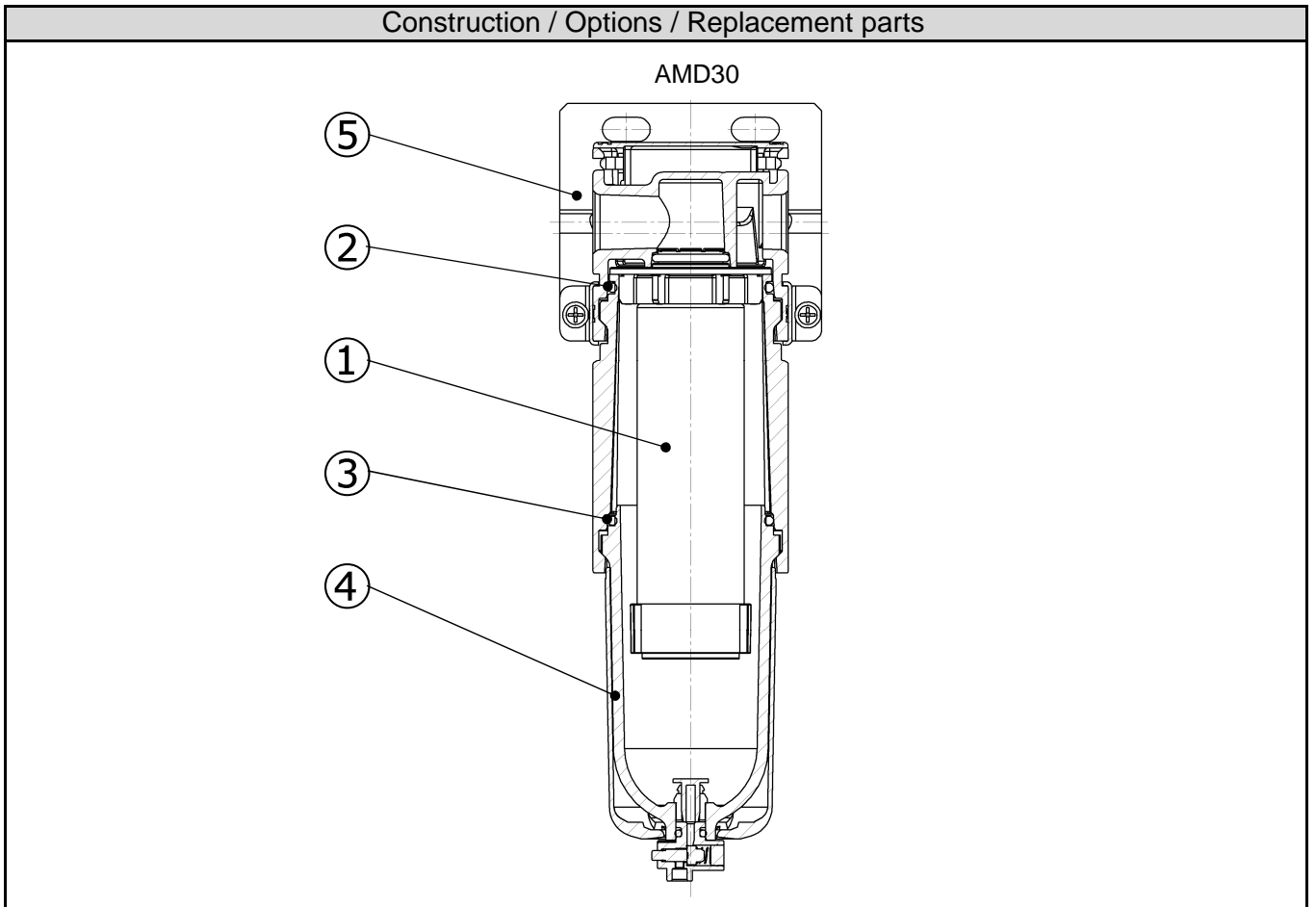

Table of replacement part

part number	description	part number
		AMD30
①	Element assembly	AMD34P-060AS
②	Bowl seal	C3SFP-260S
③		
④	Bowl assembly	Refer to [6.Bowl assembly specifications](P11 to P13).
	Auto drain (N.C.)	
	Auto drain (N.O.)	

Note) The numbers in the table and construction are consistent with the number in [10. Replacement work procedure](P18 to 21) and [11. Disassembly Drawing](P22).

Option

part number	description	part number
		AMD30
⑤	Bracket assembly ^{Note1)}	AF34P-070AS

Note) The numbers in the table and construction are consistent with the number in [10. Replacement work procedure](P18 to 21) and [11. Disassembly Drawing](P22).

Note1) Assembly of the mounting bracket (2 types) and set screw (2pcs.).

6. Bowl assembly specifications

1) AMD30 bowl assembly / auto drain

Option symbol	—		—																													
Semi-standard symbol	—	6	J	6J																												
Appearance and part number	<p>Semi-standard symbol: — (Standard)</p> <table border="1"> <tr> <td>Thead type</td> <td>(4)part number</td> </tr> <tr> <td>Rc</td> <td>C3SF-A</td> </tr> <tr> <td>G</td> <td>C3SF-A</td> </tr> <tr> <td>NPT</td> <td>C3SF-(Z)-A</td> </tr> </table> <p>Semi-standard symbol: 6</p> <table border="1"> <tr> <td>Thead type</td> <td>(4)part number</td> </tr> <tr> <td>Rc</td> <td>C3SF-6-A</td> </tr> <tr> <td>G</td> <td>C3SF-6-A</td> </tr> </table>		Thead type	(4)part number	Rc	C3SF-A	G	C3SF-A	NPT	C3SF-(Z)-A	Thead type	(4)part number	Rc	C3SF-6-A	G	C3SF-6-A	<p>Semi-standard symbol: J</p> <table border="1"> <tr> <td>Thead type</td> <td>(4)part number</td> </tr> <tr> <td>Rc</td> <td>C3SF-J-A</td> </tr> <tr> <td>G</td> <td>C3SFF-J-A</td> </tr> <tr> <td>NPT</td> <td>C3SFN-J(Z)-A</td> </tr> </table> <p>Semi-standard symbol: 6J</p> <table border="1"> <tr> <td>Thead type</td> <td>(4)part number</td> </tr> <tr> <td>Rc</td> <td>C3SF-6J-A</td> </tr> <tr> <td>G</td> <td>C3SFF-6J-A</td> </tr> </table>		Thead type	(4)part number	Rc	C3SF-J-A	G	C3SFF-J-A	NPT	C3SFN-J(Z)-A	Thead type	(4)part number	Rc	C3SF-6J-A	G	C3SFF-6J-A
Thead type	(4)part number																															
Rc	C3SF-A																															
G	C3SF-A																															
NPT	C3SF-(Z)-A																															
Thead type	(4)part number																															
Rc	C3SF-6-A																															
G	C3SF-6-A																															
Thead type	(4)part number																															
Rc	C3SF-J-A																															
G	C3SFF-J-A																															
NPT	C3SFN-J(Z)-A																															
Thead type	(4)part number																															
Rc	C3SF-6J-A																															
G	C3SFF-6J-A																															
Option symbol	—		—																													
Semi-standard symbol	W	6W	—																													
Appearance and part number	<p>Semi-standard symbol: W</p> <table border="1"> <tr> <td>Thead type</td> <td>(4)part number</td> </tr> <tr> <td>Rc</td> <td>C3SF-W-A</td> </tr> <tr> <td>G</td> <td>C3SF-W-A</td> </tr> <tr> <td>NPT</td> <td>C3SF-W(Z)-A</td> </tr> </table> <p>Semi-standard symbol: 6W</p> <table border="1"> <tr> <td>Thead type</td> <td>(4)part number</td> </tr> <tr> <td>Rc</td> <td>C3SF-6W-A</td> </tr> <tr> <td>G</td> <td>C3SF-6W-A</td> </tr> <tr> <td>NPT</td> <td>C3SF-6W(Z)-A</td> </tr> </table>		Thead type	(4)part number	Rc	C3SF-W-A	G	C3SF-W-A	NPT	C3SF-W(Z)-A	Thead type	(4)part number	Rc	C3SF-6W-A	G	C3SF-6W-A	NPT	C3SF-6W(Z)-A	—													
Thead type	(4)part number																															
Rc	C3SF-W-A																															
G	C3SF-W-A																															
NPT	C3SF-W(Z)-A																															
Thead type	(4)part number																															
Rc	C3SF-6W-A																															
G	C3SF-6W-A																															
NPT	C3SF-6W(Z)-A																															
Option symbol	—		—																													
Semi-standard symbol	2		2J																													
Appearance and part number	<p>Semi-standard symbol: 2</p> <table border="1"> <tr> <td>Thead type</td> <td>(4)part number</td> </tr> <tr> <td>Rc</td> <td>C3SF-2-A</td> </tr> <tr> <td>G</td> <td>C3SF-2-A</td> </tr> <tr> <td>NPT</td> <td>C3SF-2(Z)-A</td> </tr> </table>		Thead type	(4)part number	Rc	C3SF-2-A	G	C3SF-2-A	NPT	C3SF-2(Z)-A	<p>Semi-standard symbol: 2J</p> <table border="1"> <tr> <td>Thead type</td> <td>(4)part number</td> </tr> <tr> <td>Rc</td> <td>C3SF-2J-A</td> </tr> <tr> <td>G</td> <td>C3SFF-2J-A</td> </tr> <tr> <td>NPT</td> <td>C3SFN-2J(Z)-A</td> </tr> </table>		Thead type	(4)part number	Rc	C3SF-2J-A	G	C3SFF-2J-A	NPT	C3SFN-2J(Z)-A												
Thead type	(4)part number																															
Rc	C3SF-2-A																															
G	C3SF-2-A																															
NPT	C3SF-2(Z)-A																															
Thead type	(4)part number																															
Rc	C3SF-2J-A																															
G	C3SFF-2J-A																															
NPT	C3SFN-2J(Z)-A																															

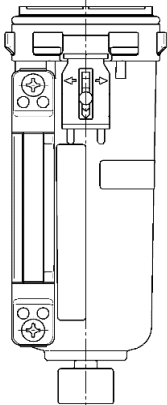
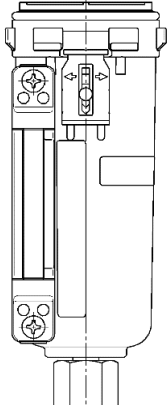
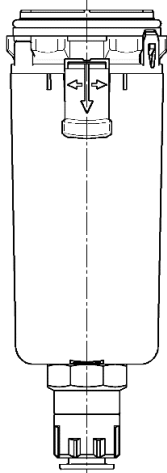
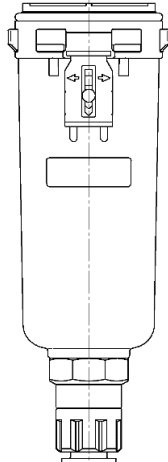
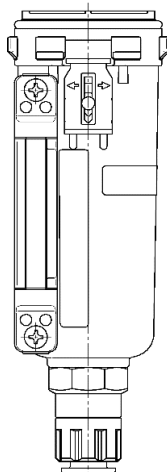
Option symbol	—		—																							
Semi-standard symbol	8		8J																							
Appearance and part number	<p>Semi-standard symbol: 8</p> <table border="1"> <thead> <tr> <th>Thead type</th> <th>(4)part number</th> </tr> </thead> <tbody> <tr> <td>Rc</td> <td>C3LF-8-A</td> </tr> <tr> <td>G</td> <td>C3LF-8-A</td> </tr> <tr> <td>NPT</td> <td>C3LF-8(Z)-A</td> </tr> </tbody> </table> 	Thead type	(4)part number	Rc	C3LF-8-A	G	C3LF-8-A	NPT	C3LF-8(Z)-A	<p>Semi-standard symbol: 8J</p> <table border="1"> <thead> <tr> <th>Thead type</th> <th>(4)part number</th> </tr> </thead> <tbody> <tr> <td>Rc</td> <td>C3LF-8J-A</td> </tr> <tr> <td>G</td> <td>C3LFF-8J-A</td> </tr> <tr> <td>NPT</td> <td>C3LFN-8J(Z)-A</td> </tr> </tbody> </table> 	Thead type	(4)part number	Rc	C3LF-8J-A	G	C3LFF-8J-A	NPT	C3LFN-8J(Z)-A								
Thead type	(4)part number																									
Rc	C3LF-8-A																									
G	C3LF-8-A																									
NPT	C3LF-8(Z)-A																									
Thead type	(4)part number																									
Rc	C3LF-8J-A																									
G	C3LFF-8J-A																									
NPT	C3LFN-8J(Z)-A																									
Option symbol	C ^{Note1)}		C ^{Note1)}																							
Semi-standard symbol	—	6	2																							
Appearance and part number	<p>Semi-standard symbol: —</p> <table border="1"> <thead> <tr> <th>Thead type</th> <th>(4)part number</th> </tr> </thead> <tbody> <tr> <td>Rc</td> <td>AD37-A</td> </tr> <tr> <td>G</td> <td>AD37-A</td> </tr> <tr> <td>NPT</td> <td>AD37N(-Z)-A</td> </tr> </tbody> </table> <p>Semi-standard symbol: 6</p> <table border="1"> <thead> <tr> <th>Thead type</th> <th>(4)part number</th> </tr> </thead> <tbody> <tr> <td>Rc</td> <td>AD37-6-A</td> </tr> <tr> <td>G</td> <td>AD37-6-A</td> </tr> <tr> <td>NPT</td> <td>AD37N-6(Z)-A</td> </tr> </tbody> </table> 	Thead type	(4)part number	Rc	AD37-A	G	AD37-A	NPT	AD37N(-Z)-A	Thead type	(4)part number	Rc	AD37-6-A	G	AD37-6-A	NPT	AD37N-6(Z)-A	<p>Semi-standard symbol: 2</p> <table border="1"> <thead> <tr> <th>Thead type</th> <th>(4)part number</th> </tr> </thead> <tbody> <tr> <td>Rc</td> <td>AD37-2-A</td> </tr> <tr> <td>G</td> <td>AD37-2-A</td> </tr> <tr> <td>NPT</td> <td>AD37N-2(Z)-A</td> </tr> </tbody> </table> 	Thead type	(4)part number	Rc	AD37-2-A	G	AD37-2-A	NPT	AD37N-2(Z)-A
Thead type	(4)part number																									
Rc	AD37-A																									
G	AD37-A																									
NPT	AD37N(-Z)-A																									
Thead type	(4)part number																									
Rc	AD37-6-A																									
G	AD37-6-A																									
NPT	AD37N-6(Z)-A																									
Thead type	(4)part number																									
Rc	AD37-2-A																									
G	AD37-2-A																									
NPT	AD37N-2(Z)-A																									
Option symbol	C ^{Note1)}																									
Semi-standard symbol	8																									
Appearance and part number	<p>Semi-standard symbol: 8</p> <table border="1"> <thead> <tr> <th>Thead type</th> <th>(4)part number</th> </tr> </thead> <tbody> <tr> <td>Rc</td> <td>AD37-8-A</td> </tr> <tr> <td>G</td> <td>AD37-8-A</td> </tr> <tr> <td>NPT</td> <td>AD37N-8(Z)-A</td> </tr> </tbody> </table> 	Thead type	(4)part number	Rc	AD37-8-A	G	AD37-8-A	NPT	AD37N-8(Z)-A	<p>Note1) Min. operating pressure is 0.1 MPa. Note2) (4)Part number includes (3) Bowl seal. Refer to [11. Disassembly Drawing](P22). Note3) [Z] in (4) part number indicates standard specifications. The unit of pressure is psi and °F. Note4) Refer to [4. How to Order](P9) for symbol for options and semi-standard.</p>																
Thead type	(4)part number																									
Rc	AD37-8-A																									
G	AD37-8-A																									
NPT	AD37N-8(Z)-A																									

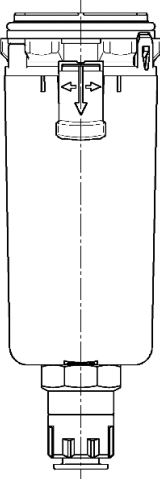
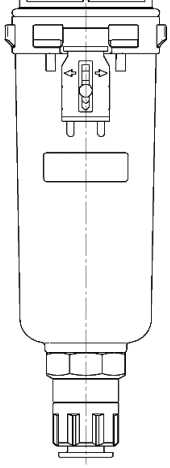
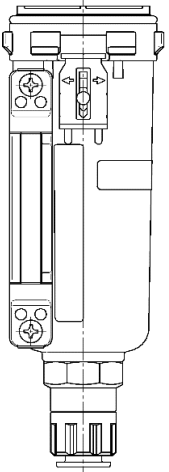
Option symbol	D ^{Note1)}		D ^{Note1)}																			
Semi-standard symbol	—	6	2																			
Appearance and part number	Semi-standard symbol: — <table border="1"> <tr> <td>Thead type</td> <td>(4)part number</td> </tr> <tr> <td>Rc</td> <td>AD38-A</td> </tr> <tr> <td>G</td> <td></td> </tr> <tr> <td>NPT</td> <td>AD38N(-Z)-A</td> </tr> </table>		Thead type	(4)part number	Rc	AD38-A	G		NPT	AD38N(-Z)-A		Semi-standard symbol: 2 <table border="1"> <tr> <td>Thead type</td> <td>(4)part number</td> </tr> <tr> <td>Rc</td> <td>AD38-2-A</td> </tr> <tr> <td>G</td> <td></td> </tr> <tr> <td>NPT</td> <td>AD38N-2(Z)-A</td> </tr> </table>		Thead type	(4)part number	Rc	AD38-2-A	G		NPT	AD38N-2(Z)-A	
	Thead type	(4)part number																				
Rc	AD38-A																					
G																						
NPT	AD38N(-Z)-A																					
Thead type	(4)part number																					
Rc	AD38-2-A																					
G																						
NPT	AD38N-2(Z)-A																					
Semi-standard symbol: 6 <table border="1"> <tr> <td>Thead type</td> <td>(4)part number</td> </tr> <tr> <td>Rc</td> <td>AD38-6-A</td> </tr> <tr> <td>G</td> <td></td> </tr> <tr> <td>NPT</td> <td>AD38N-6(Z)-A</td> </tr> </table>		Thead type	(4)part number	Rc	AD38-6-A	G		NPT	AD38N-6(Z)-A													
Thead type	(4)part number																					
Rc	AD38-6-A																					
G																						
NPT	AD38N-6(Z)-A																					
Option symbol	D ^{Note1)}																					
Semi-standard symbol	8																					
Appearance and part number	Semi-standard symbol: 8 <table border="1"> <tr> <td>Thead type</td> <td>(4)part number</td> </tr> <tr> <td>Rc</td> <td>AD38-8-A</td> </tr> <tr> <td>G</td> <td></td> </tr> <tr> <td>NPT</td> <td>AD38N-8(Z)-A</td> </tr> </table>			Thead type	(4)part number	Rc	AD38-8-A	G		NPT	AD38N-8(Z)-A											
Thead type	(4)part number																					
Rc	AD38-8-A																					
G																						
NPT	AD38N-8(Z)-A																					

Note1) Min. operating pressure is 0.1 MPa.

Note2) (4)Part number includes (3) Bowl seal. Refer to [11. Disassembly Drawing](P22).

Note3) [Z] in (4) Part number indicates standard specifications. The unit of pressure is psi and °F.

Note4) Refer to [4. How to Order](P9) for symbol for options and semi-standard.

7. Assembly of Optional parts

1) Bracket

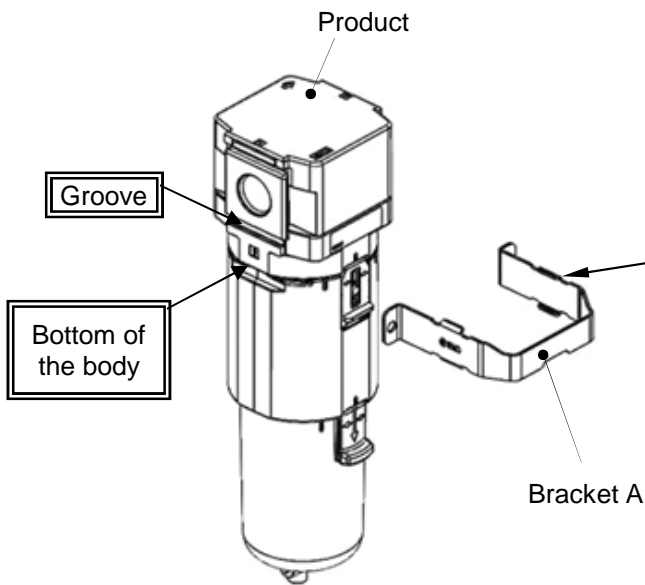

- 1) Mounting of the bracket A
 Insert bracket A from the front side of the product so that the finger of the bracket A engages with the groove and the bottom of the body (see drawing on the left).

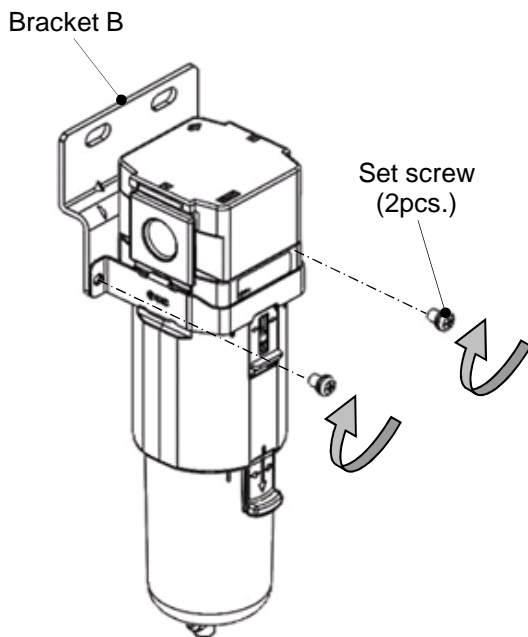

- 2) Mounting of the bracket B
 Fix bracket B with the two set screws included in the package. Refer to the table below for the tightening torque.

Micro Misto Separator	Tools	Tightening torque
AMD30	Phillips screwdrive(+)	0.75+/-0.2 N · m

8. Operation and Adjustment

1) Discharging the product with drain cock

- Pressurize the inside with air when discharging, otherwise the drain will not discharge properly.
- Drain discharge mechanism is different depending on the bowl assembly. Check the bowl assembly and discharge the drain following the correct method below.
Rotation type: After discharging the drain, tighten the drain cock to the opposite direction by hand until the seal inside seals correctly.
Use of a tool can damage the product.

AMD30: With drain cock and barb fitting (push type)
(Polycarbonate / nylon bowl)

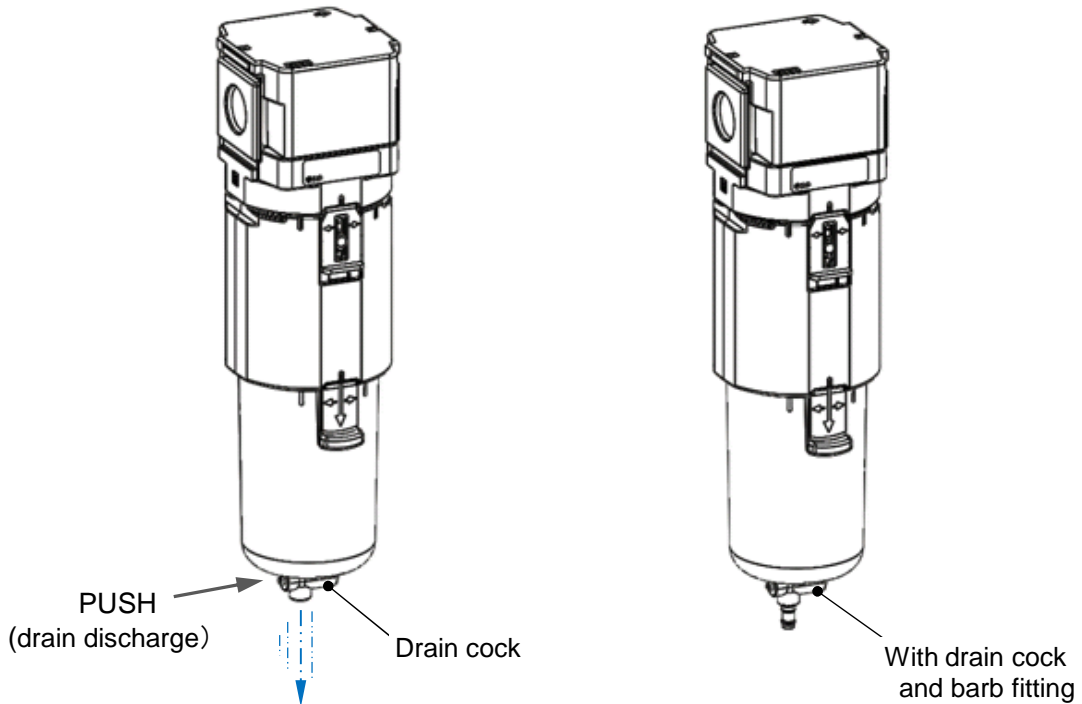

AMD30: Drain cock (rotation type)
(Metal bowl / metal bowl with level gauge)

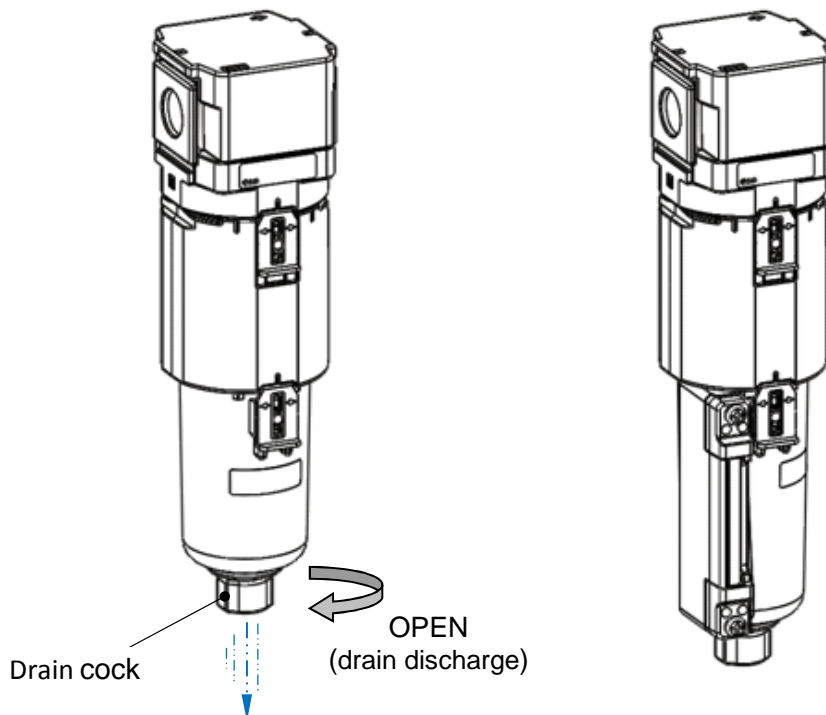

2)Manual discharge of the auto drain

- Pressurize the inside with air when discharging, otherwise the drain will not discharge properly.
- To discharge the auto drain by hand, follow the procedure below.
After discharging the drain, rotate the drain cock to the opposite direction by hand to close the drain valve.
Use of a tool can damage the product.

AMD30: Auto drain

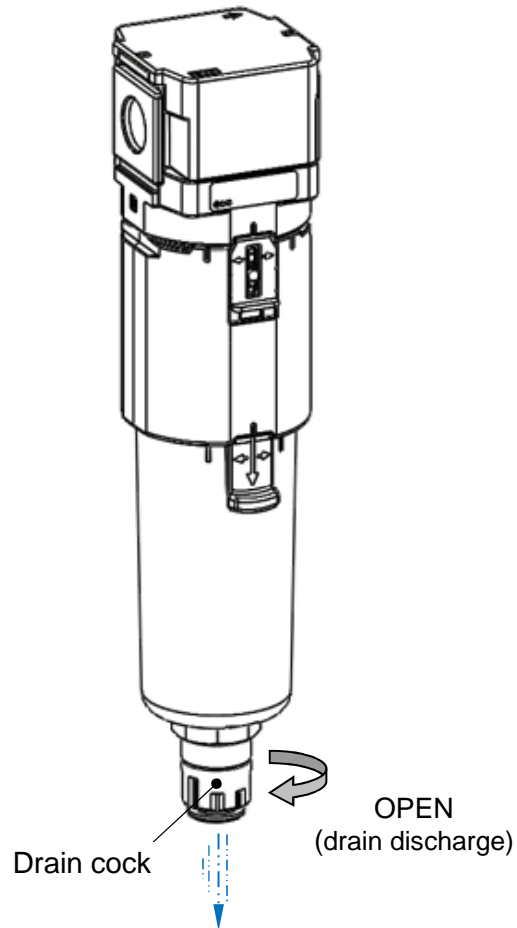

9. Troubleshooting

Refer to [10. Replacement work procedure](P18 to 21) and 11. Disassembly Drawing](P22).

Failure		Possible causes	Countermeasures	Page for reference
Category	Phenomenon			
Flow rate	As pressure drop is large, fluid does not flow.	1. Clog of the element.	Replace the element.	P18 to 19
	Air leakage from between the body and fitting.	1. Breakage of joint seal.	Replace the bowl packing.	P18 to 19
Air leaks	Air leaks between the joint and the bowl.	1. Breakage of the bowl seal.	Replace the bowl packing.	P20 to 21
	Air leakage from the bowl.	1. Bowl is damaged.	Replace the bowl assembly. (If the solvent is considered to be harmful, replacement to the metal bowl is recommended)	P20 to 21
	Air leaks from the drain cock.	1. The foreign matter caught in the valve of the drain cock.	Open the drain cock for a few seconds for blowing.	P15 to 16
		2. Breakage of the seating part of the drain cock.	Replace the bowl assembly.	P20 to 21
	Drainage or air continues blowing out of the drain discharge of the float type auto drain.	1. Low supply pressure.	Ensure that the ball valve of the auto drain is opened.	P11 to 13
		2. The product is not mounted correctly.	Install the drain exhaust so that it will face vertically downward.	-
		3. Foreign matter is caught at the main valve of the auto drain.	Remove the dust by manual drain discharge.	P15 to 16
		4. Main valve of the auto drain is broken.	Replace the bowl assembly.	P20 to 21
		5. Drain piping is long, or I.D. of the piping is small. (Back pressure is applied.)	Be sure to connect the appropriate piping for drain.	P5 to 6
		6. Drain exhaust and bowl seat were broken.	Replace the bowl assembly.	P20 to 21
Operability	Drain is not discharging when the drain cock opens.	1. Blockage of outlet of the drain cock due to solid foreign matter etc.	Replace the bowl assembly.	P20 to 21
	Too much drain comes from the piping of outlet side.	1. Drain level reaches the bottom of the element.	Open the drain cock for draining and replace the element.	P15 to 16 P18 to 19

Note) Fluorine grease is recommended when applying additional grease.

10. Replacement work procedure

⚠ Caution

Before replacement, ensure that this equipment is not pressurized.

After replacement, ensure that specified function is satisfied and external leakage is not found before starting operation.

1-1) Element Replacement - disassembly [AMD30]

Step 1

To remove the joint from the body, rotate for approx. 30 degrees with the lock button held down. Align the mating mark of the body and joint and pull down the bowl assembly to remove it.

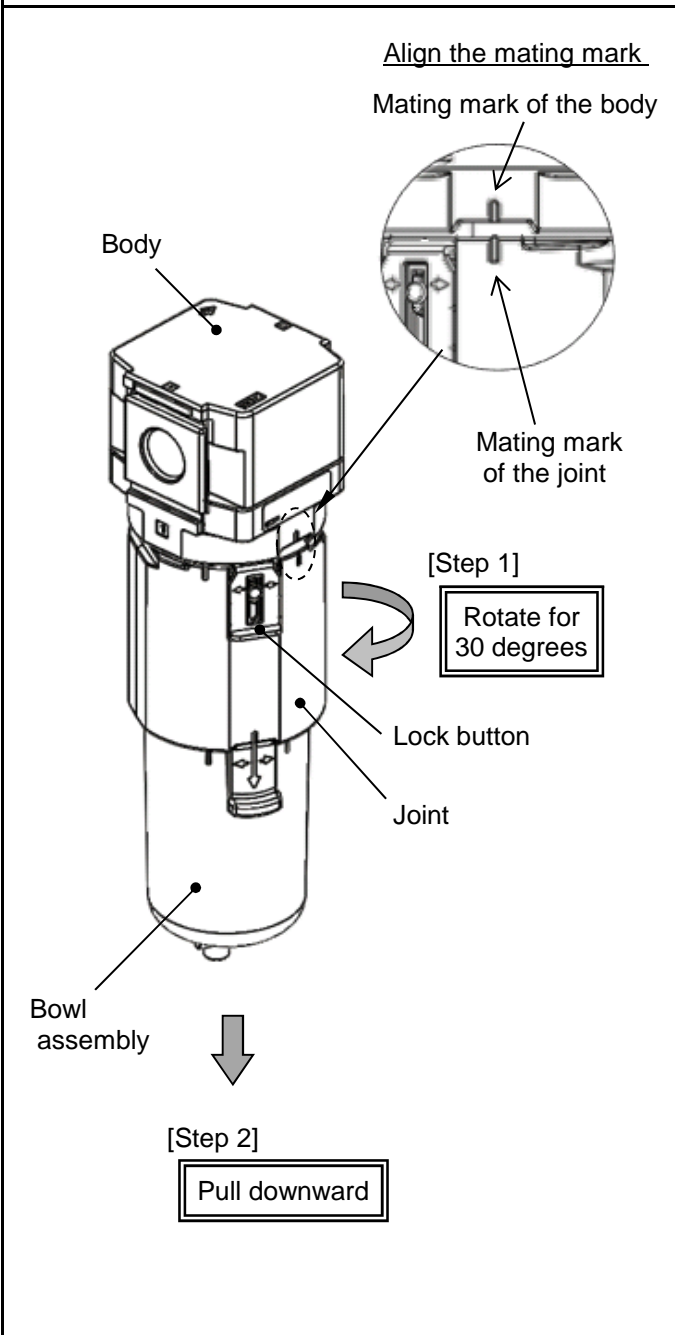

Step 2

Hold the element as shown below and pull upward to remove the element assembly.

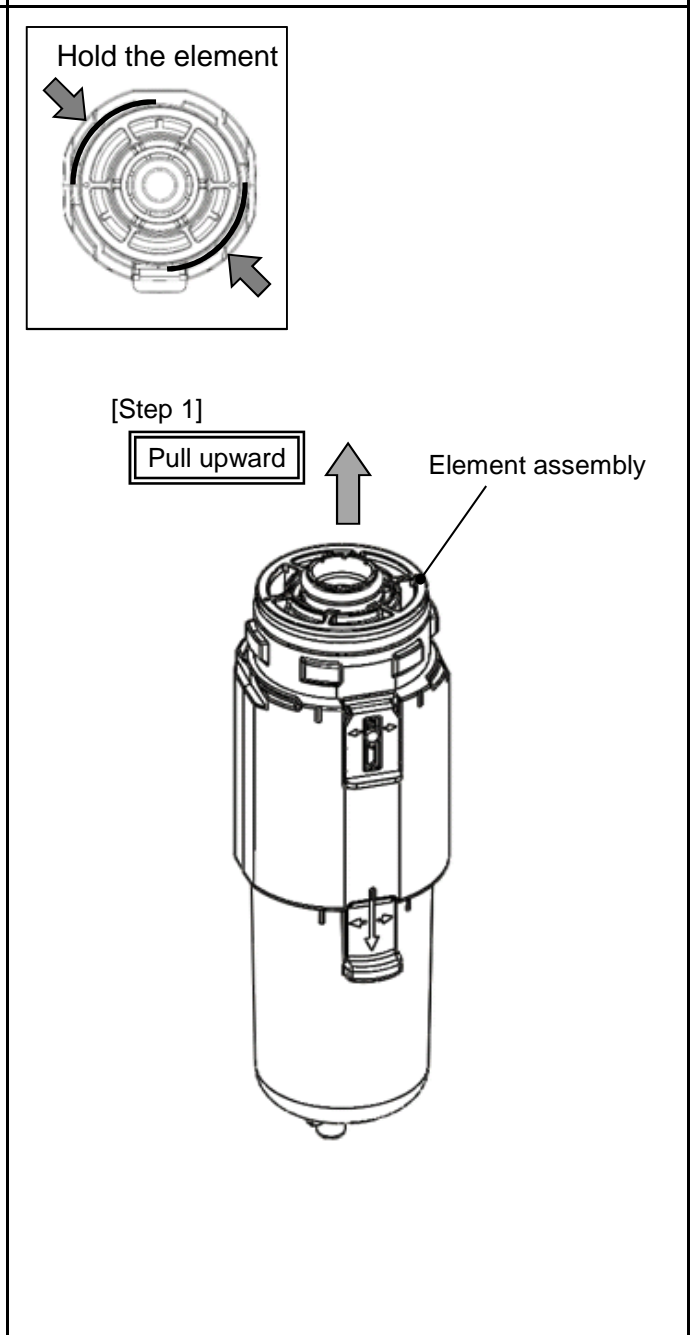

1-2) Element Replacement - Assembly [AMD30]

Step 1

Mount the element so that the arrow mark on top of the element and the joint lock button are in the position shown below. If they are forced to be inserted without aligning, the element will break.

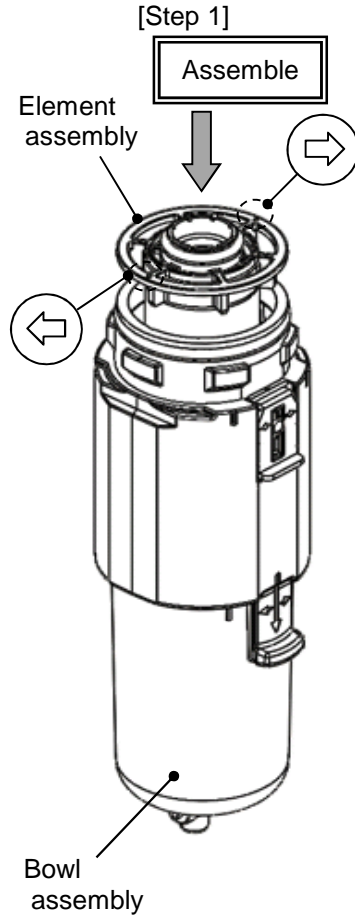
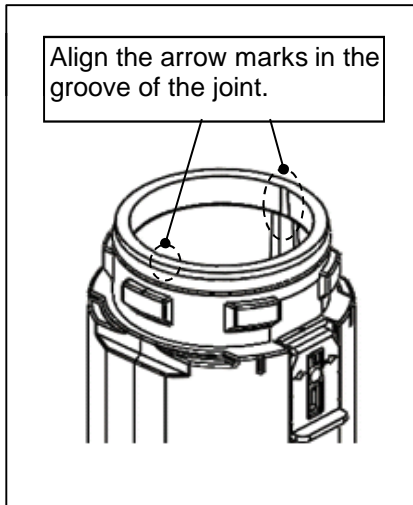
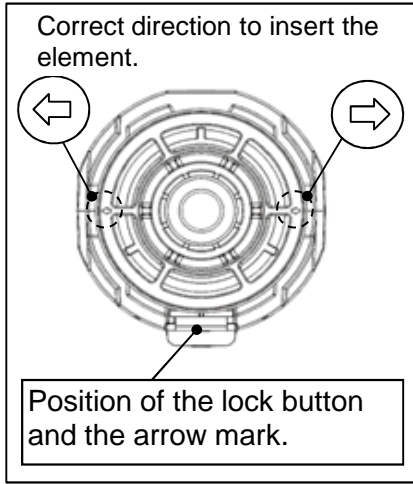

Step 2

While the lock button is held down, mount the body and joint where their marks meet. Rotate the joint until the lock button meets the body groove (approx. 30°).

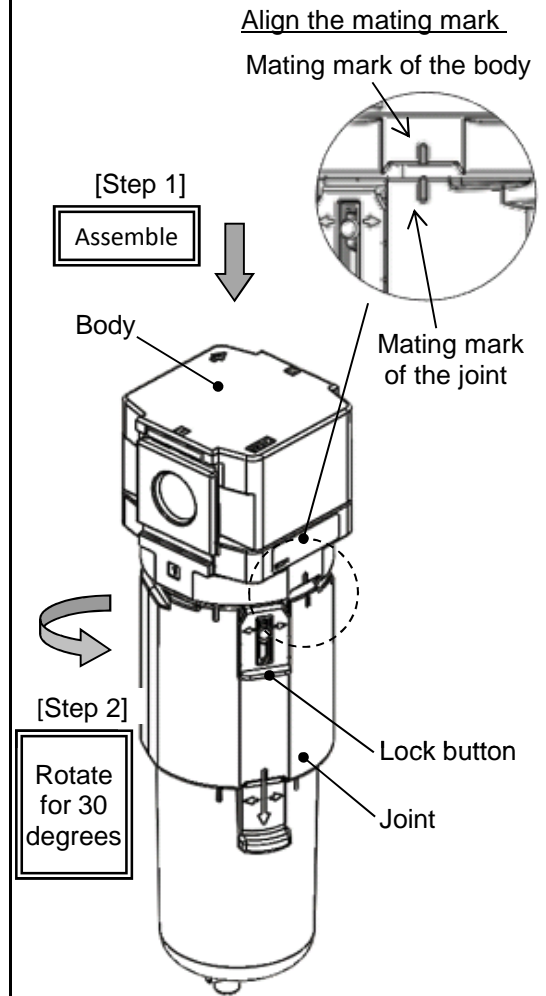

Confirm the lock button is locked to the flute of the product before it pressurizes it.

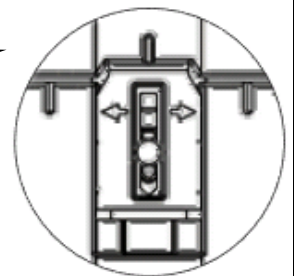

10. Replacement work procedure

2-1) Bowl Replacement - Disassembly [AMD30]

Step 1

To remove the bowl assembly from the product, rotate for approx. 30 degrees while the lock button is held down. Align the mating mark of the joint and bowl assembly and pull the bowl assembly down to remove it.

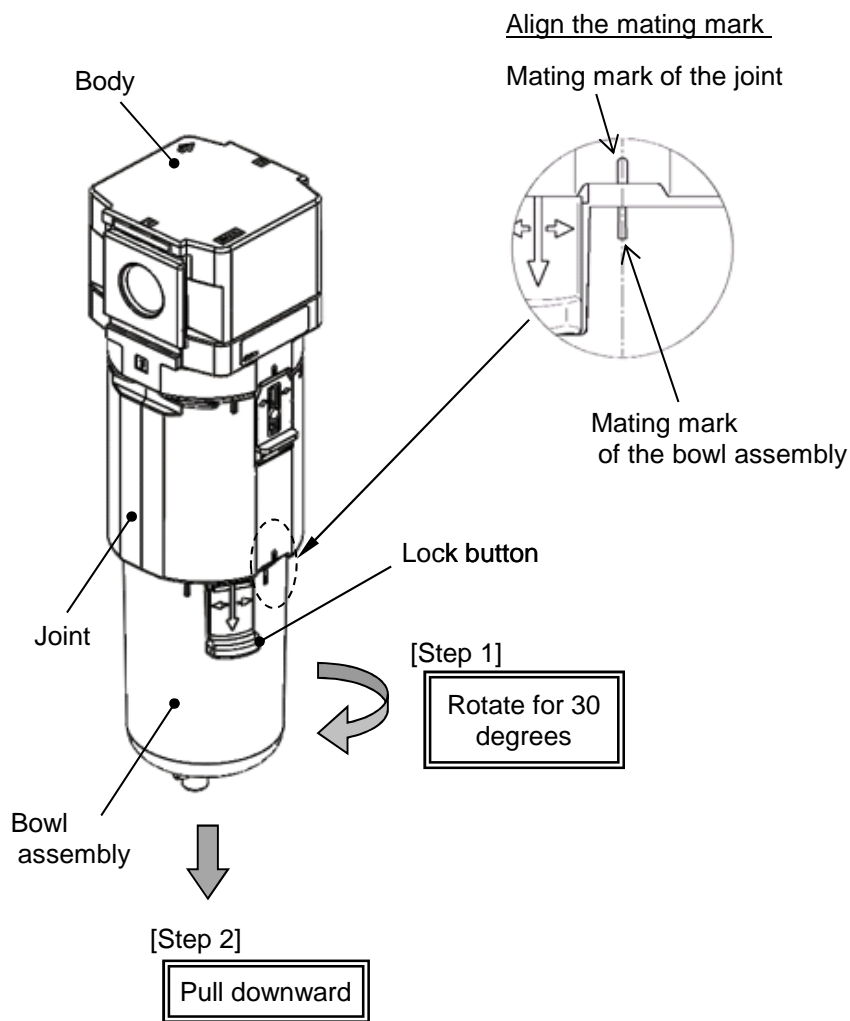

10. Replacement work procedure

2-2) Bowl Replacement - Assembly [AMD30]

Step 1

Mount the bowl assembly at the position where the mating mark of the joint and bowl assembly meet.

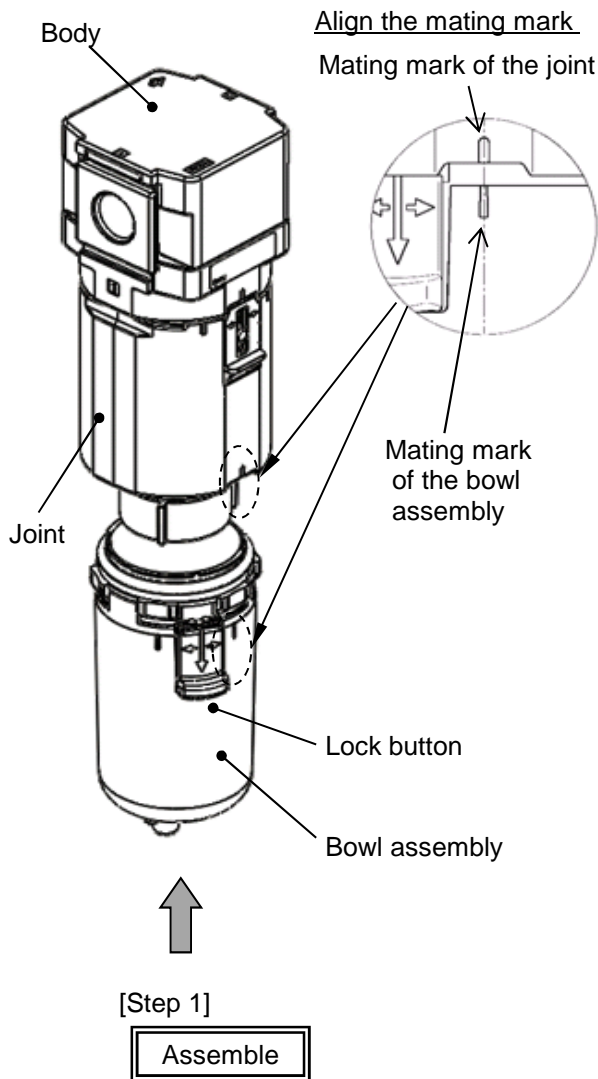

Step 2

While the lock button is held down, rotate the bowl assembly so that the lock button meets the groove of the joint (approx. 30°).

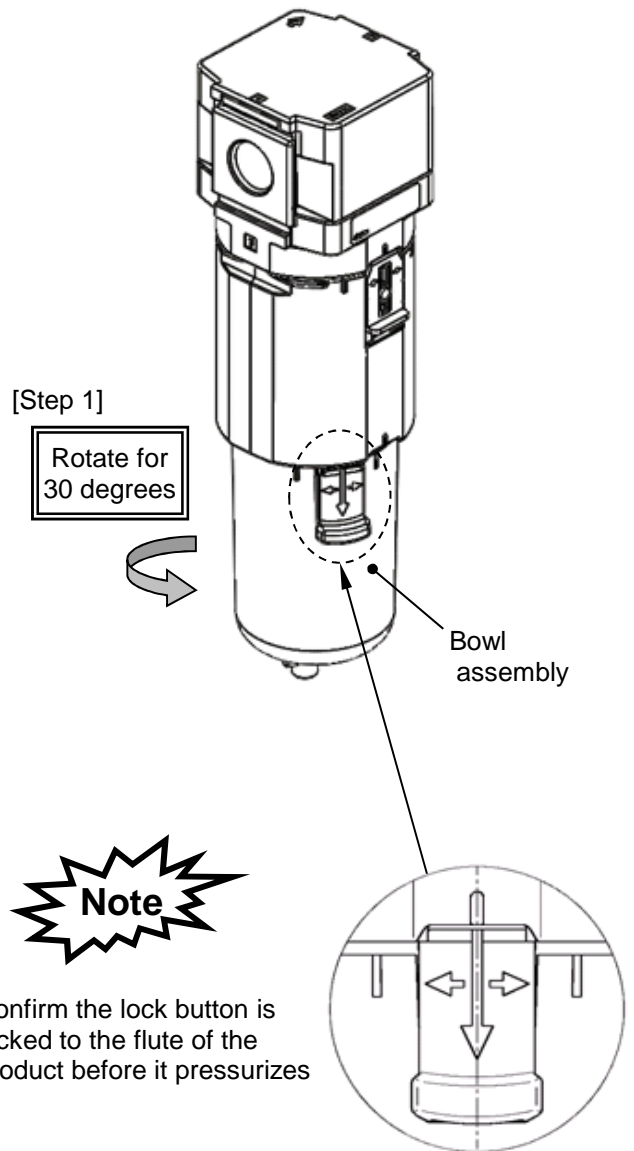

11. Exploded Drawing

1) Exploded drawing of AMD30

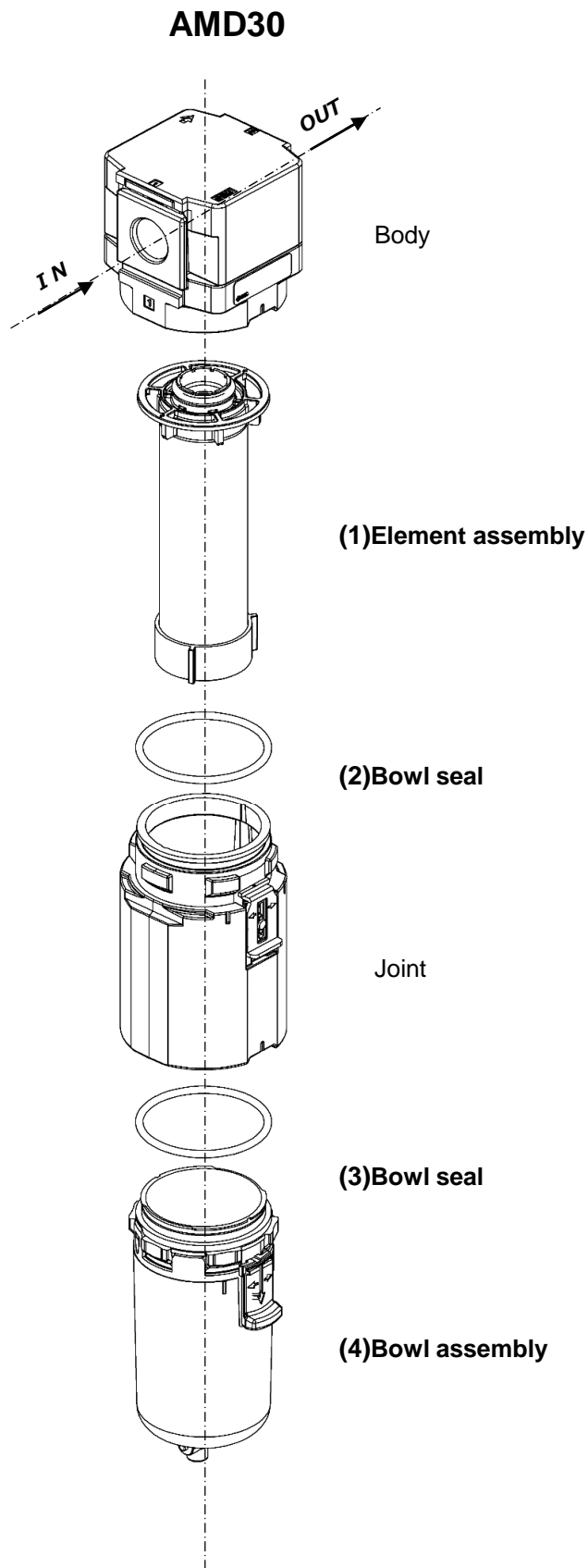

12. Dimensions

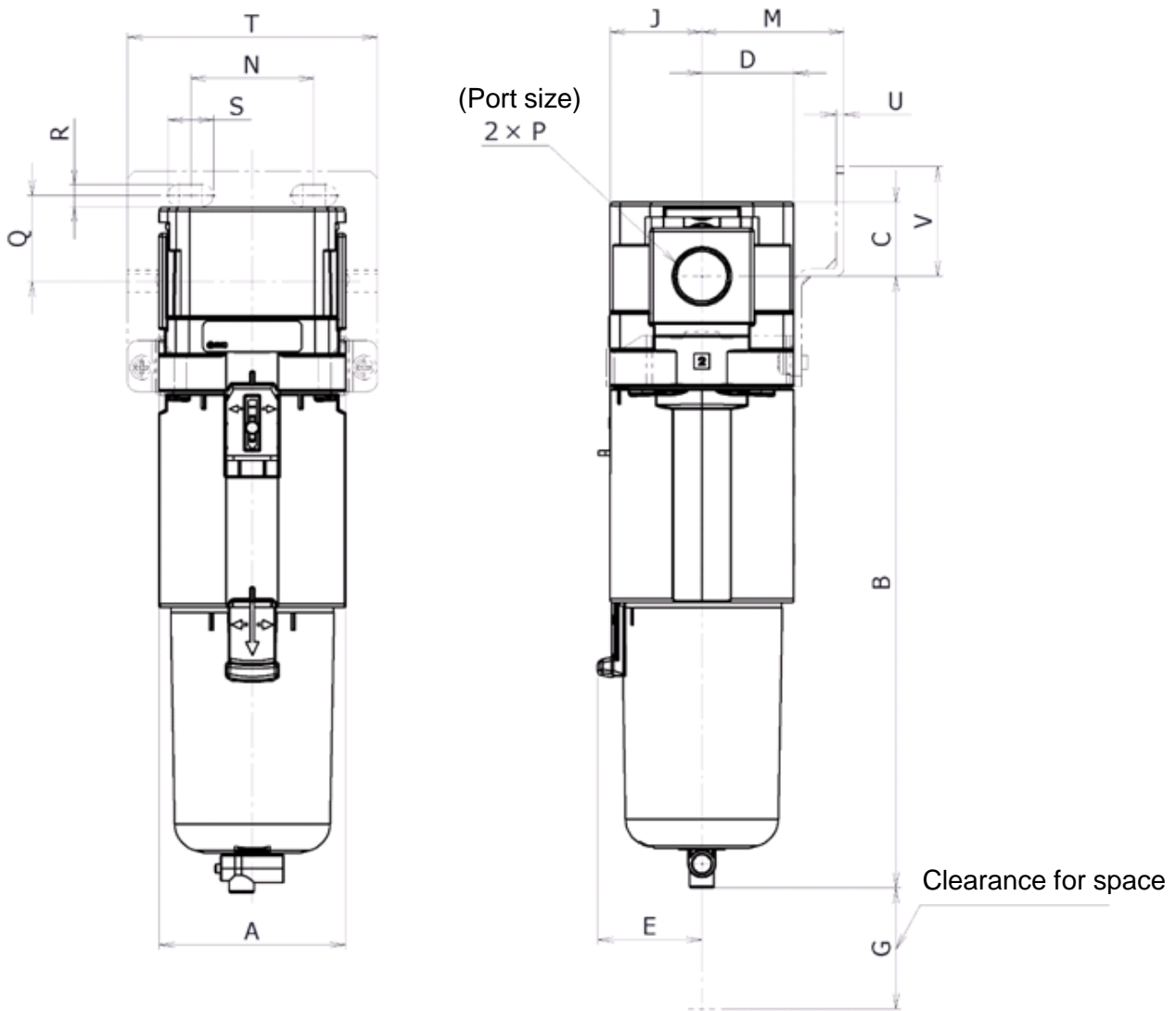

Model	Semi-standard							Bracket mounting dimensions								
	P	A	B	C	D	E	G	J	M	N	Q	R	S	T	U	V
AMD30	1/4•3/8	53	178.1	21.5	26.5	30	35	26.5	41	35	25	6.5	13	71	2.3	32

Auto drain/semi-standard bowl

Model	Auto drain			Semi-standard specification					
	PC/PA bowl	Metal bowl	Metal bowl with level gauge	PC/PA bowl		Metal bowl		Metal bowl with level gauge	
				Barb fitting	With drain guide	With drain cock	With drain guide	With drain cock	With drain guide
B	B	B	B	B	B	B	B	B	B
AMD30	219.8	219.8	219.8	186.6	184.9	180.6	185.1	200.6	205.1

Revision history

SMC Corporation

4-14-1, Sotokanda, Chiyoda-ku, Tokyo 101-0021 JAPAN

Tel: + 81 3 5207 8249 Fax: +81 3 5298 5362

URL <https://www.smcworld.com>

Note: Specifications are subject to change without prior notice and any obligation on the part of the manufacturer.
© 2019 SMC Corporation All Rights Reserved