



# Operation Manual

PRODUCT NAME

Fieldbus system  
(SI unit compatible CompoNet™)

MODEL / Series / Product Number

*EX12#-SCM#*

**SMC Corporation**



## Table of Contents

Safety Instructions	2
Product Summary	7
Model Identification and How to Order	7
Summary of Product parts	8
Mounting and Installation	10
Wiring	10
Setting	14
Mounting of Objects	15
Maintenance	22
Troubleshooting	23
Specifications	26
Specifications	26
Dimensions	27

## Safety Instructions

These safety instructions are intended to prevent hazardous situations and/or equipment damage. These instructions indicate the level of potential hazard with the labels of "Caution", "Warning" or "Danger". They are all important notes for safety and must be followed in addition to International standards (ISO/IEC) \*1) and other safety regulations.

- \*1) ISO 4414: Pneumatic fluid power -- General rules relating to systems.
- ISO 4413: Hydraulic fluid power -- General rules relating to systems.
- IEC 60204-1: Safety of machinery -- Electrical equipment of machines. (Part 1: General requirements)
- ISO 10218-1992: Manipulating industrial robots -Safety.
- etc.

-  **Caution** : CAUTION indicates a hazard with a low level of risk which, if not avoided, could result in minor or moderate injury.
-  **Warning** : WARNING indicates a hazard with a medium level of risk which, if not avoided, could result in death or serious injury.
-  **Danger** : DANGER indicates a hazard with a high level of risk which, if not avoided, will result in death or serious injury.

### **Warning**

- 1. The compatibility of the product is the responsibility of the person who designs the equipment or decides its specifications.**

Since the product specified here is used under various operating conditions, its compatibility with specific equipment must be decided by the person who designs the equipment or decides its specifications based on necessary analysis and test results. The expected performance and safety assurance of the equipment will be the responsibility of the person who has determined its compatibility with the product. This person should also continuously review all specifications of the product referring to its latest catalog information, with a view to giving due consideration to any possibility of equipment failure when configuring the equipment.
- 2. Only personnel with appropriate training should operate machinery and equipment.**

The product specified here may become unsafe if handled incorrectly. The assembly, operation and maintenance of machines or equipment including our products must be performed by an operator who is appropriately trained and experienced.
- 3. Do not service or attempt to remove product and machinery/equipment until safety is confirmed.**
  1. The inspection and maintenance of machinery/equipment should only be performed after measures to prevent falling or runaway of the driven objects have been confirmed.
  2. When the product is to be removed, confirm that the safety measures as mentioned above are implemented and the power from any appropriate source is cut, and read and understand the specific product precautions of all relevant products carefully.
  3. Before machinery/equipment is restarted, take measures to prevent unexpected operation and malfunction.
- 4. Contact SMC beforehand and take special consideration of safety measures if the product is to be used in any of the following conditions.**
  1. Conditions and environments outside of the given specifications, or use outdoors or in a place exposed to direct sunlight.
  2. Installation on equipment in conjunction with atomic energy, railways, air navigation, space, shipping, vehicles, military, medical treatment, combustion and recreation, or equipment in contact with food and beverages, emergency stop circuits, clutch and brake circuits in press applications, safety equipment or other applications unsuitable for the standard specifications described in the product catalog.
  3. An application which could have negative effects on people, property, or animals requiring special safety analysis.
  4. Use in an interlock circuit, which requires the provision of double interlock for possible failure by using a mechanical protective function, and periodical checks to confirm proper operation.

## **Caution**

### **The product is provided for use in manufacturing industries.**

The product herein described is basically provided for peaceful use in manufacturing industries. If considering using the product in other industries, consult SMC beforehand and exchange specifications or a contract if necessary.  
If anything is unclear, contact your nearest sales branch.

## **Limited warranty and Disclaimer/Compliance Requirements**

The product used is subject to the following "Limited warranty and Disclaimer" and "Compliance Requirements".

Read and accept them before using the product.

### **Limited warranty and Disclaimer**

1. The warranty period of the product is 1 year in service or 1.5 years after the product is delivered. \*2)  
Also, the product may have specified durability, running distance or replacement parts. Please consult your nearest sales branch.
2. For any failure or damage reported within the warranty period which is clearly our responsibility, a replacement product or necessary parts will be provided.  
This limited warranty applies only to our product independently, and not to any other damage incurred due to the failure of the product.
3. Prior to using SMC products, please read and understand the warranty terms and disclaimers noted in the specified catalog for the particular products.

\*2) Vacuum pads are excluded from this 1 year warranty.

A vacuum pad is a consumable part, so it is warranted for a year after it is delivered.

Also, even within the warranty period, the wear of a product due to the use of the vacuum pad or failure due to the deterioration of rubber material are not covered by the limited warranty.

### **Compliance Requirements**

1. The use of SMC products with production equipment for the manufacture of weapons of mass destruction (WMD) or any other weapon is strictly prohibited.
2. The exports of SMC products or technology from one country to another are governed by the relevant security laws and regulation of the countries involved in the transaction. Prior to the shipment of a SMC product to another country, assure that all local rules governing that export are known and followed.

## Operator

- ◆ This operation manual is intended for those who have knowledge of machinery using pneumatic equipment, and have sufficient knowledge of assembly, operation and maintenance of such equipment. Only those persons are allowed to perform assembly, operation and maintenance.
- ◆ Read and understand this operation manual carefully before assembling, operating or providing maintenance to the product.

### ■ Precautions

#### **Warning**

- Do not disassemble, modify (including changing the printed circuit board) or repair.  
An injury or failure can result.
- Do not operate the product outside of the specifications.  
Do not use for flammable or harmful fluids.  
Fire, malfunction, or damage to the product can result.  
Verify the specifications before use.
- Do not operate in an atmosphere containing flammable or explosive gases.  
Fire or an explosion can result.  
This product is not designed to be explosion proof.
- If using the product in an interlocking circuit:
  - Provide a double interlocking system, for example a mechanical system.
  - Check the product regularly for proper operationOtherwise malfunction can result, causing an accident.
- The following instructions must be followed during maintenance:
  - Turn off the power supply
  - Stop the air supply, exhaust the residual pressure and verify that the air is released before performing maintenanceOtherwise an injury can result.

#### **Caution**

- After maintenance is complete, perform appropriate functional inspections.  
Stop operation if the equipment does not function properly.  
Safety cannot be assured in the case of unexpected malfunction.
- Provide grounding to assure the safety and noise resistance of the SI unit.  
Individual grounding should be provided close to the product with a short cable.

## ■NOTE

- Follow the instructions given below when designing, selecting and handling the product.
- The instructions on design and selection (installation, wiring, environment, adjustment, operation, maintenance, etc.) described below must also be followed.
  - \*Product specifications
    - When conformity to UL is required, the SI unit should be used with a UL1310 Class 2 power supply.
    - Use the specified voltage.
      - Otherwise failure or malfunction can result.
    - Reserve a space for maintenance.
      - Allow sufficient space for maintenance when designing the system.
    - Do not remove any nameplates or labels.
      - This can lead to incorrect maintenance, or misreading of the operation manual, which could cause damage or malfunction to the product.
- Precautions on handling
  - \*Installation
    - Do not drop, hit or apply excessive shock to the SI unit.
      - Otherwise damage to the product can result, causing malfunction.
    - Tighten to the specified tightening torque. (refer to page 13)
      - If the tightening torque is exceeded the mounting screws may be broken.
    - Never mount a product in a location that will be used as a foothold.
      - The product may be damaged if excessive force is applied by stepping or climbing onto it.
  - \*Wiring
    - Avoid repeatedly bending or stretching the cables, or placing heavy load on them.
      - Repetitive bending stress or tensile stress can cause breakage of the cable.
    - Wire correctly.
      - Incorrect wiring can break the product.
    - Do not perform wiring while the power is on.
      - Otherwise damage to the SI unit and/or I/O device can result, causing malfunction.
    - Do not route wires and cables together with power or high voltage cables.
      - Otherwise the SI unit and/or I/O device can malfunction due to interference of noise and surge voltage from power and high voltage cables to the signal line.
      - Route the wires (piping) of the SI unit and/or I/O device separately from power or high voltage cables.
    - Confirm proper insulation of wiring.
      - Poor insulation (interference from another circuit, poor insulation between terminals, etc.) can lead to excess voltage or current being applied to the product, causing damage.
    - Take appropriate measures against noise, such as using a noise filter, when the SI unit is incorporated into equipment.
      - Otherwise noise can cause malfunction.

#### \*Environment

- Do not use the product in area that is exposed to corrosive gases, chemicals, sea water, water or steam.  
Otherwise failure or malfunction can result.
- Do not use in an area where surges are generated.  
If there is equipment which generates a large amount of surge (solenoid type lifter, high frequency induction furnace, motor, etc.) close to the SI unit, this may cause deterioration or breakage of the internal circuit of the SI unit. Avoid sources of surge generation and crossed lines.
- Prevent foreign matter such as remnant of wires from entering the SI unit to avoid failure and malfunction.
- Mount the product in a place that is not exposed to vibration or impact.  
Otherwise failure or malfunction can result.
- Do not use the product in an environment that is exposed to temperature cycle.  
Heat cycles other than ordinary changes in temperature can adversely affect the inside of the product.
- Do not expose the product to direct sunlight.  
If using in a location directly exposed to sunlight, shade the product from the sunlight.  
Otherwise failure or malfunction can result.
- Keep within the specified ambient temperature range.  
Otherwise malfunction can result.
- Do not operate close to a heat source, or in a location exposed to radiant heat.  
Otherwise malfunction can result.

#### \*Adjustment and Operation

- Set the switches by using a sharp-pointed screwdriver etc.  
It may damage set switches.
- Perform settings suitable for the operating conditions.  
Incorrect setting can cause operation failure.  
For details of each setting, refer to page 14 of this manual.
- Please refer to the PLC manufacturer's manual etc. for details of programming and addresses.  
For the PLC protocol and programming refer to the relevant manufacturer's documentation.

#### \*Maintenance

- Turn off the power supply, stop the supplied air, exhaust the residual pressure and verify the release of air before performing maintenance.  
There is a risk of unexpected malfunction.
- Perform regular maintenance and inspections.  
There is a risk of unexpected malfunction.
- After maintenance is complete, perform appropriate functional inspections.  
Stop operation if the equipment does not function properly.  
Otherwise safety is not assured due to an unexpected malfunction or incorrect operation.
- Do not use solvents such as benzene, thinner etc. to clean the SI unit.  
They could damage the surface of the body and erase the markings on the body.  
Use a soft cloth to remove stains.  
For heavy stains, use a cloth soaked with diluted neutral detergent and fully squeezed, then wipe up the stains again with a dry cloth.

## Product Summary

EX12#-SCM# is an SI (serial interface) unit that can be connected to CompoNet™. The following are the specifications and instructions for handling.

## Model Indication and How to Order

- SI unit series EX120

### EX120-SCM1

Applicable network

CM1	NPN output for CompoNet™
CM3	PNP output for CompoNet™

Valve interface

EX120	Plug-in
EX121	Flat ribbon cable, DIN rail mounting
EX122	Plug-in, DIN rail mounting

- Part number for accessories

### EX9-CCM1

Communication connector (No attached the product.)

CM1	For flat ribbon cable: IDC connector
CM2	For round cable (VCTF): Terminal block connector

### EX9-CP2

Power supply connector

P2	Straight type (Attached the product.)
P3	T-branch type *

\*: EX9-CP3 is not included with the product. Please order separately.



## Summary of Product parts

### •EX120 series

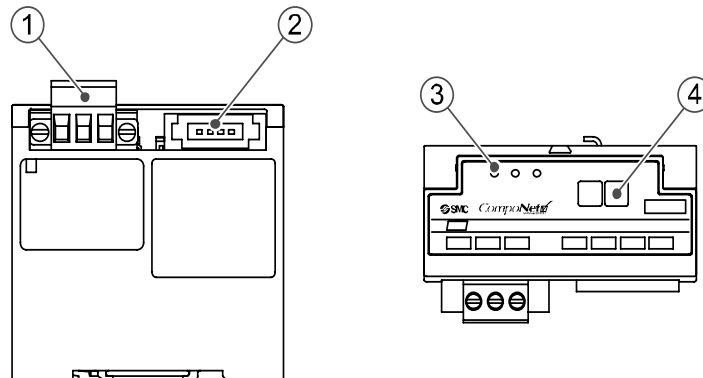

### •EX121 series

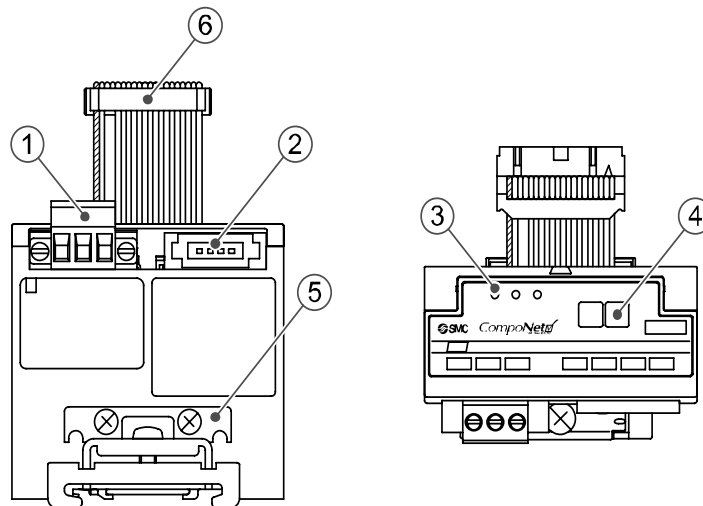

### •EX122 series

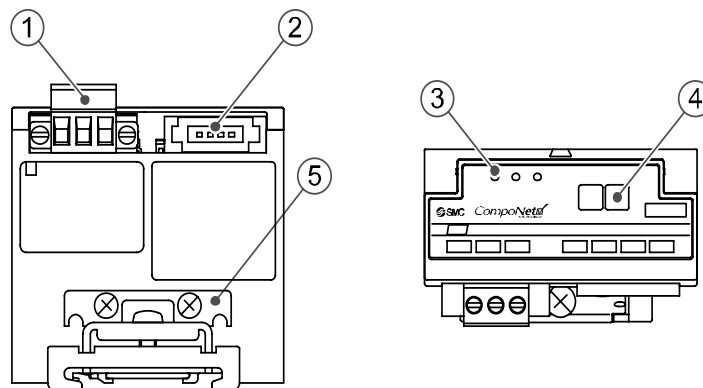

No.	Name	Purpose
1	Power supply connector	Connect to the power supply for solenoid valve.
2	Communication connector	Connect to the CompoNet™ network.
3	Display	The status of the unit is indicated by LED.
4	Setting switch area	For setting the node number.
5	Mounting bracket	For mounting to a DIN rail.
6	MIL connector	Connect to the solenoid valve.

•Accessories

**Communication connector:** IDC connector for flat ribbon cable  
(EX9-CCM1: Not supplied with product)  
Applied when using a flat ribbon cable dedicated for use with CompoNet™ products.

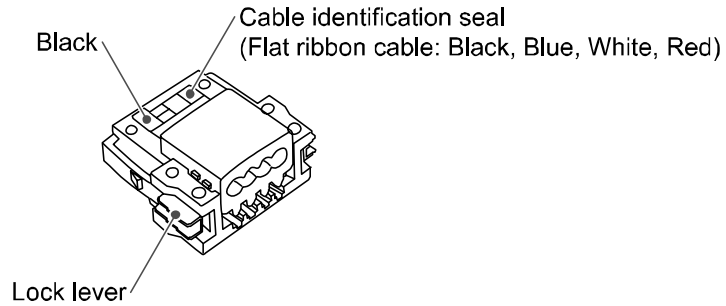

**Communication connector:** Terminal block connector for round cable (VCTF)  
(EX9-CCM2: Not supplied with product)  
Applied when a VCTF cable is used.

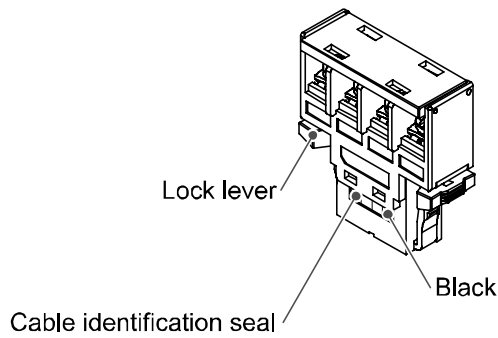

**Power supply connector:** Straight type  
(EX9-CP2: 1 pc. supplied with product)

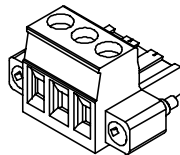

**Power supply connector:** T-branch type  
(EX9-CP3: 1 pc. supplied with product)

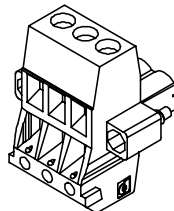

# Mounting and Installation

## ■Wiring

### •Internal circuit

#### •NPN (EX12#-SCM1)

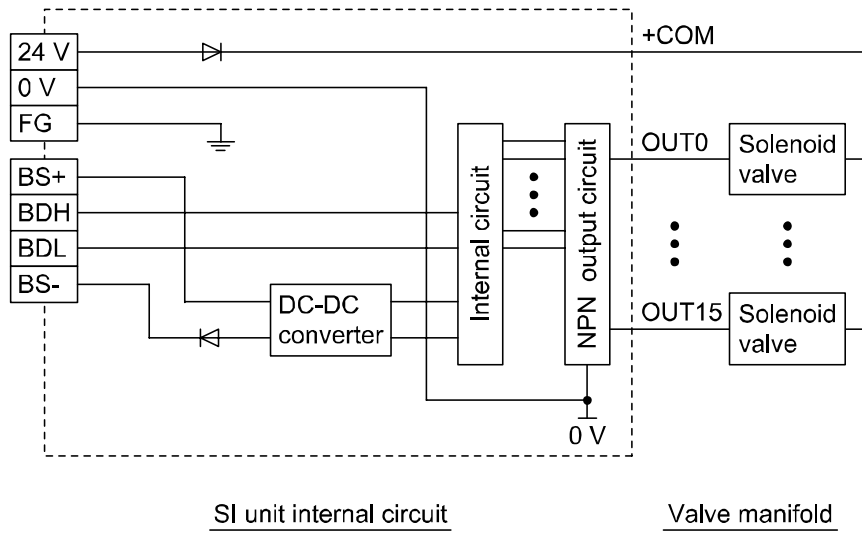

#### •PNP (EX12#-SCM3)

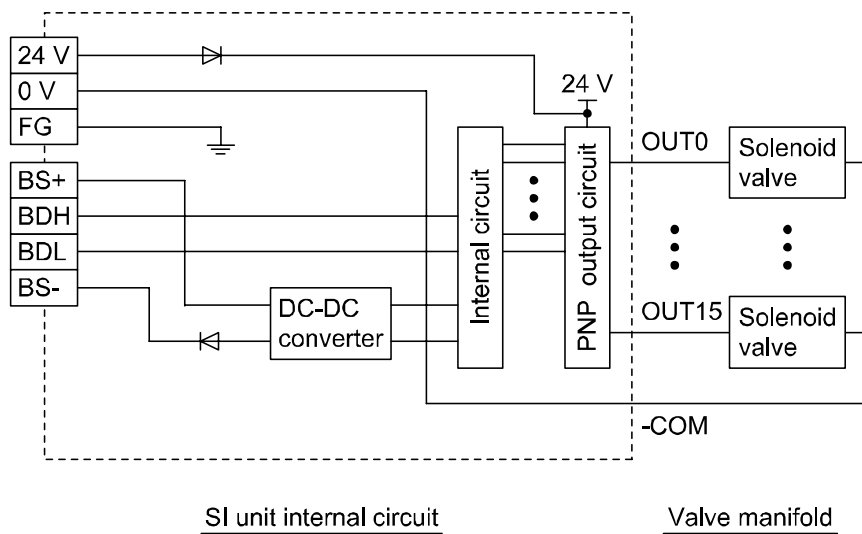

## 1, Communication wiring

The network cable and communication connector for CompoNet™ are connected in the following manner.

<b>Note</b>			
The communication connector for the SI unit should be as shown below.			
	Communication connector		
	SMC	OMRON	HONDA TSUSHIN KOGYO
For flat ribbon cable: IDC connector	EX9-CCM1	DCN4-BR4	-
For round cable: Terminal block connector	EX9-CCM2	-	HCN-TB4LMZG+

We do not provide a tool that is used for wiring IDC connector.  
Please contact OMRON for further details.

### •Connection of IDC connector for flat ribbon cable

#### 1, Cutting of cable

Cut the cable vertically.

Use a tool with sharp edges such as a nipper to prevent short-circuit, and check there are no whiskers of wire sticking out.

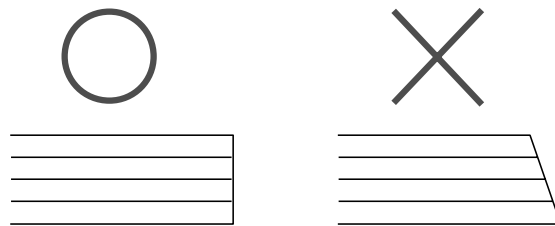

#### 2, Connection of cable

Match the cable identification color with the color of the cable and insert the cable.

The cover is translucent to make it possible to check the cable reaches the end.

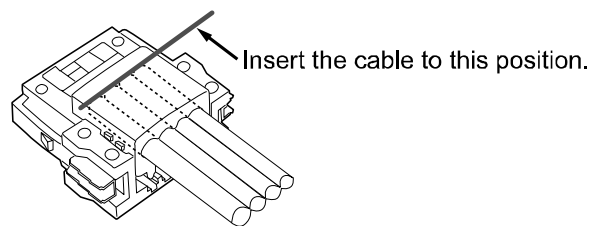

#### 3, Pressure-welding the connector

Use a tool (OMRON, DWT-A01) to connect wires.

(1) As shown below, place the connector cover so that its center (arrowed part) is at the center of the IDC block of the tool.

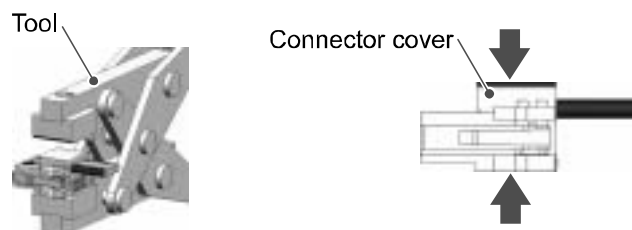

(2) Squeeze firmly on the DWT-A01 Pliers until the lock on the connector clicks into place.

**Note**

- Do not pressure-weld the connector cover at the edges.
- Do not pressure-weld the connector cover at the back of the pressure welding block.
- Set the connector in the correct orientation.

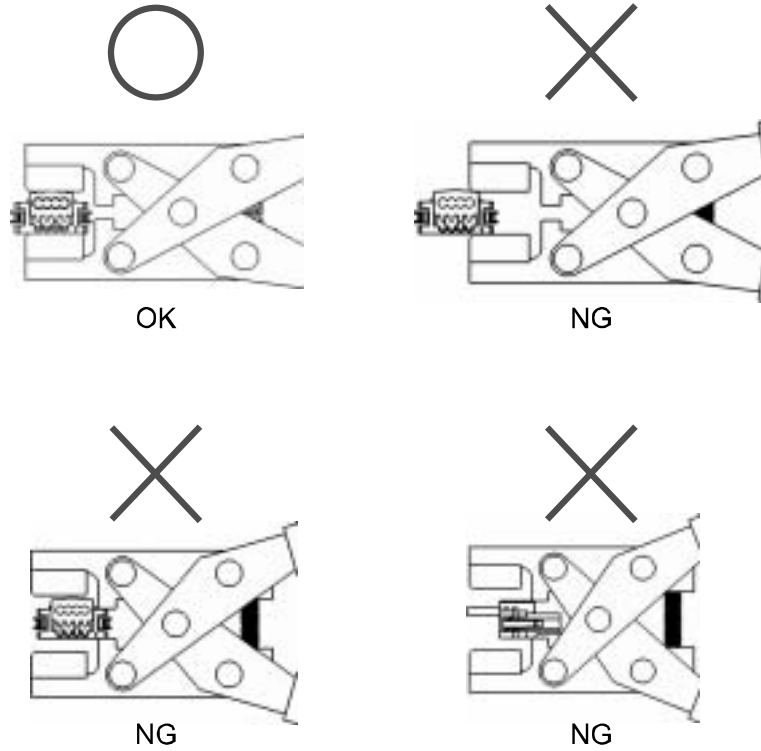

(3) After attaching the cable, confirm that it is properly pressure-welded.

No gap in this face



•Connection of terminal block for round cable

1, Removal of protective coating

Remove the protective coating, taking care not to damage the sheath of the internal signal cable.

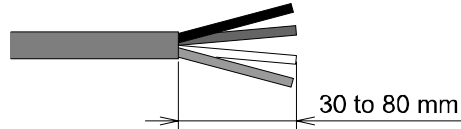

2, Removal of sheath of signal cable

Remove the sheath of the signal cable to a length corresponding to the crimped part of the crimping terminal used.

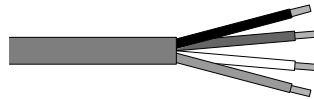

3, Mounting of crimping terminal

Use the crimping terminal for wiring. Do not connect electrical wires which are just twisted directly to the terminal block.

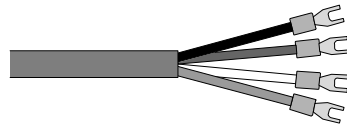

4, Mounting to the connector

The available crimped terminal is M3 type.

The terminal screws should be firmly tightened to 0.3 to 0.5 Nm.

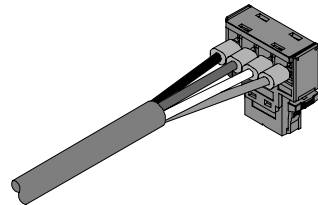

**2. Power supply wiring (Solenoid valve power supply)**

Connect the wiring for the solenoid valve power supply to the power supply connector (EX9-CP2) etc. Tighten the screw with 0.5 to 0.6 Nm of tightening torque.

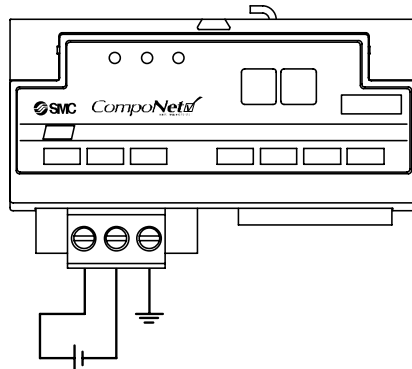

Solenoid valve  
power supply 24 VDC

# Setting

## •LED indication

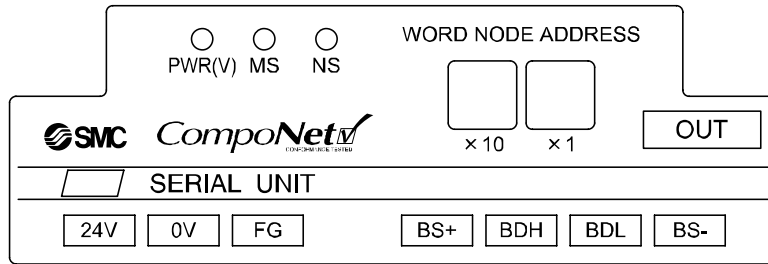

Display	Meaning
PWR (V)	Solenoid valve power supply ON : Lights up Solenoid valve power supply OFF : Goes off
MS	Unit in normal operation : Green lights up Fatal error : Red lights up Minor error : Red flashes Power supply off : All lights go off
NS	On line/Connection completed : Green lights up On line/Connection not completed: Green flashes Fatal communication error : Red lights up Minor communication error : Red flashes Power supply off : All lights go off

## •Switch setting

- The node setting is conducted using the rotary switch inside the unit cover.
- Make sure the switch setting is carried out with the power supply turned off.
- The switch should be set using a small flat screwdriver.
- An automatic transmission speed setup function allows slaves to automatically comply with the transmission speeds set by the master. Therefore, there are no switches to set.

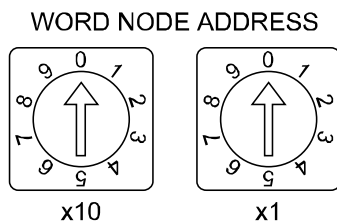

Setting	Setting range
x10	0 to 6
x1	0 to 9

- \*1: The station number should be any number from 00 to 63.  
If a node is set to a number greater than 63, the "NS" LED will light up.  
After turning the power off, set to the correct number.
- \*2: The address number cannot be duplicated.

## Mounting of Objects

This SI unit covers the CompoNet™ object classes below.

### Identity object (0x01)

Object class	Attributes	Unsupport				
	Services	Unsupport				
Object instance	Attributes	ID	Meaning	GET	SET	Value
		0x01	Vendor ID	O	-	7 (7H)
		0x02	Device type	O	-	27 (1BH)
		0x03	Product code	O	-	128 (80H)
		0x04	Revision	O	-	Per unit
		0x05	Status(bits supported)	O	-	Only bit0
		0x06	Serial number	O	-	Per unit
		0x07	Product name	O	-	EX12#-SCM# (ASCII)
	0x64	Product Revision	O	-	Per unit	
	Services	Cord	Meaning	Parameter option		
		0x05	Reset	-		
0x0E		Get_Attribute_Single	-			

\*: The identify class is reset by software. Restart the unit after that.

### Message router object (0x02)

Object class	Attributes	Unsupport
	Services	Unsupport
Object instance	Attributes	Unsupport
	Services	Unsupport
Addition of vendor specific specifications		None

### Assembly object (0x04)

Object class	Attributes	Unsupport						
	Services	Unsupport						
Object instance	Section	Information				Number of maximum		
	Type	Static I/O				1		
	Attributes	ID	Meaning			GET	SET	Value
		0x01	Number of Members in List			-	-	-
		0x02	Member List			-	-	-
	0x03	Data			O	-	-	
	Services	Cord	Meaning			Parameter option		
		0x0E	Get_Attribute_Single			-		

### Digital I/O slave (Output)

Instance	Byte offset	Data							
		bit7				bit0			
35 (0x23)	+0	7	6	5	4	3	2	1	0
	+1	15	14	13	12	11	10	9	8



Connection object (0x05)

Object class	Attributes	ID	Meaning	GET	SET	Value
		0x01	Revision	O	-	0001H
	Services	Cord	Meaning	Parameter option		
		0x0E	Get_Attribute_Single	-		

Object instance	Section	Information			Number of maximum	
	Instance type	POLL			1	
	Production trigger	Cyclic			-	
	Transport type	Server				
	Transport class	3				
	Attributes	ID	Meaning	GET	SET	Value
		0x01	State	O	-	-
		0x02	Instance type	O	-	01H
		0x03	Transport class trigger	O	-	80H
		0x04	Produced connection ID	O	-	-
		0x05	Consumed connection ID	O	-	-
		0x06	Initial comm. characteristics	O	-	01H
		0x07	Produced connection size	O	-	64H
		0x08	Consumed connection size	O	-	64H
		0x09	Expected packed rate	O	-	-
		0x0C	Watchdog timeout action	O	-	00H
		0x0D	Produced connection path length	O	-	00H
		0x0E	Produced connection path	O	-	-
	0x0F	Consumed connection path length	O	-	00H	
	0x10	Consumed connection path	O	-	-	
	Services	Cord	Meaning	Parameter option		
		0x05	Reset	-		
		0x0E	Get_Attribute_Single	-		
0x10		Set_Attribute_Single	-			

CompoNet™ Link object (0xF7)

Object class	Attributes	ID	Meaning	GET	SET	Value
		0x01	Revision	O	-	0001H
Object class	Services	Cord	Meaning	Parameter option		
		0x0E	Get_Attribute_Single	-		
Object instance	Attributes	ID	Meaning	GET	SET	Value
		0x01	MAC ID	O	-	-
		0x02	Data Rate	O	-	-
		0x05	Allocation choice	O	-	-
		0x0A	Explicit message timer	O	O	-
	Services	Cord	Meaning	Parameter option		
		0x0E	Get_Attribute_Single	-		
		0x10	Set_Attribute_Single	-		
		0x4B	Allocate	Allocation choice, EPR, Explicit message timer		
		0x4C	Release	Release choice		

Discrete Output Point (DOP) object (0x09)

Object class	Attributes	ID	Meaning	GET	SET	Value
		0x01	Revision	O	-	0001H
		0x02	Max Instance	O	-	Number of output points
Services	Cord		Meaning	Parameter option		
	0x0E	Get_Attribute_Single		-		

Object instance	Attributes	ID	Meaning	GET	SET	Value
		0x05	Fault Action	O	O	Sets the output condition for communication error. 0: Zero clear 1: Hold output The set value is immediately reflected.
0x07	Idle Action	O	O	Setting of the output when the control is abnormal. 0: Zero clear 1: Hold output The set value is immediately reflected.		
0x65	Maintenance Counter Mode Choice	O	O	Setting of mode of maintenance counter 0: Energizing time mode (hour) 1: Contact counter mode (time) The set value is immediately reflected.		
0x66	Maintenance Counter	O	O	Present value of maintenance counter 0 to 4294967295 (00000000 to FFFFFFFF H)		
0x67	Maintenance Counter Exceed	O	-	Maintenance counter threshold over flag 0: Maintenance counter value < Threshold 1: Maintenance counter value > Threshold		
0x68	Threshold Maintenance Counter	O	O	Threshold of maintenance counter 0 to 4294967295 (00000000 to FFFFFFFF H) The set value is immediately reflected.		
Services	Cord		Meaning	Parameter option		
	0x05	Reset		Only Attribute66		
	0x0E	Get_Attribute_Single		-		
	0x10	Set_Attribute_Single		-		

Unit Manager object (0x95)

Object class	Attributes	ID	Meaning	GET	SET	Value
		0x01	Revision	O	-	0001H
	Services	Cord	Meaning	Parameter option		
		0x0E	GET_Attribute_Single	-		

Object instance	Attributes	ID	Meaning	GET	SET	Value	
		0x65	Generic Status	O	-	General purpose status *1	
		0x6B	Network Power Voltage	O	-	Network power supply voltage 100 mV units (BIN data)	
		0x6C	Max Network Power Voltage	O	-	Max. network power supply voltage	
		0x6D	Min Network Power Voltage	O	-	Min. network power supply voltage	
		0x6E	Threshold Network Power Voltage	O	O	Threshold of network power supply voltage. When the voltage falls below this set value, the status flag will turn on. The set value is immediately reflected. Default: 008CH (14.0 V)	
		0x71	Run Hours	O	-	The unit for energizing time of internal power circuit with the product. Hour 0 to 4294967295 (00000000 to FFFFFFFF H)	
		0x72	Run Hours Exceed	O	-	Energizing time threshold over flag 0: Energizing time < Threshold (default) 1: Energizing time >= Threshold	
		Services	Cord	Meaning	Parameter option		
			0x05	Reset	Attribute6C, 6D		
	0x0E		Get_Attribute_Single	-			
	0x10		Set_Attribute_Single	-			

\*1: General purpose status

Bit	Names	Explanation
0	-	-
1	-	-
2	Network Power Warning	The network power supply voltage has fallen below the threshold value. When it has fallen below the threshold: ON
3	UNIT Total time Warning	The total energizing time of the product has exceeded the threshold value. When it has exceeded the threshold: ON
4	-	-
5	-	-
6	Response Time Warning	Any of monitored operation time is outside of range: ON
7	Maintenance Counter Warning	Any of output monitored operation time is outside of range: ON

Communication Error Log object (0x96)

Object class	Attributes	ID	Meaning	GET	SET	Value
		0x01	Revision	O	-	0003H
		0x02	Max Instance	O	-	0004H
Object class	Services	Cord	Meaning	Parameter option		
		0x0E	Get_Attribute_Single	-		

Object instance	Attributes	ID	Meaning	GET	SET	Value
		0x64	Error Code	O	-	Error code 0: No error 1: Connection Time out 2: Unused 3: MAC ID duplicated Repeater configuration error
		0x67	Network Power Voltage	O	-	Network voltage when error occurs
		0x68	Run Hours	O	-	Energizing time when error occurs. Hour
		0x69	Manchester Error Rate	O	-	Error code
Object instance	Services	Cord	Meaning	Parameter option		
		0x05	Reset	-		
		0x0E	Get_Attribute_Single	-		

Equipment Manager object (0x97)

Object instance	Attributes	ID	Meaning	GET	SET	Value
		0x65	Response time	O	-	Machine response time of output point with the product [ms]
		0x66	Response time exceed	O	-	Relation of response time of machine to threshold of output point with the product 0: Within threshold 1: Over threshold
		0x67	Threshold Response Time	O	O	Response time of machine of output point with the product units [ms] The set value is immediately reflected.
		0x68	Response time peak	O	-	Peak value of response time of machine
Services	Cord	Meaning	Parameter option			
	0x05	Reset	Attribute68			
	0x0E	Get_Attribute_Single	-			
	0x10	Set_Attribute_Single	-			

# Maintenance

## Mounting and wiring

Item to inspect	Criteria	Countermeasure
Confirm the connectors (communication, power supply) of the SI unit are securely connected.	No looseness.	Tighten the connector screws. (refer to "Mounting and Installation" on page 10)
Confirm the connecting cable is not broken.	No signs of breakage.	If any breaks are found, replace the cable.

## Replacement parts

Item to inspect	Criteria	Countermeasure
Cable for moving parts (when used)	No signs of breakage and no error in the conductive resistance value. (For the resistance value, check for exceeding of specified range and balance change in pair cable.)	If any breaks and found, or the conductive resistance is incorrect, replace the cable. Refer to the cable specifications for the conductive resistance.
SI unit	No error in operation and display.	If any error is found in the operation or on the display, replace the unit.

## Power supply

Item to inspect	Criteria	Countermeasure
Confirm the voltage is within the specified range. Measure the voltages at both sides of the power supply for CompoNet™.	14 VDC to 26.4 VDC	Investigate the cause of the voltage fluctuation, and take countermeasures against it.
Confirm the voltage is within the specified range. Measure the voltages at both sides of the power supply for solenoid valves.	24 VDC +10%/-5% (refer to "Unit specification" on page 26)	

# Troubleshooting

## •Troubleshoot

Applicable model: **EX12#-SCM#**

If a SI unit gets an operation failure, look for the problem using the following flow chart.

If any cause of the problem cannot be found, and a new SI unit can operate well after replaced with the old one, the failure of SI unit is conceivable. As the failure of SI unit may happen due to the operation environment (network construction etc), consult us about the countermeasure against that case.

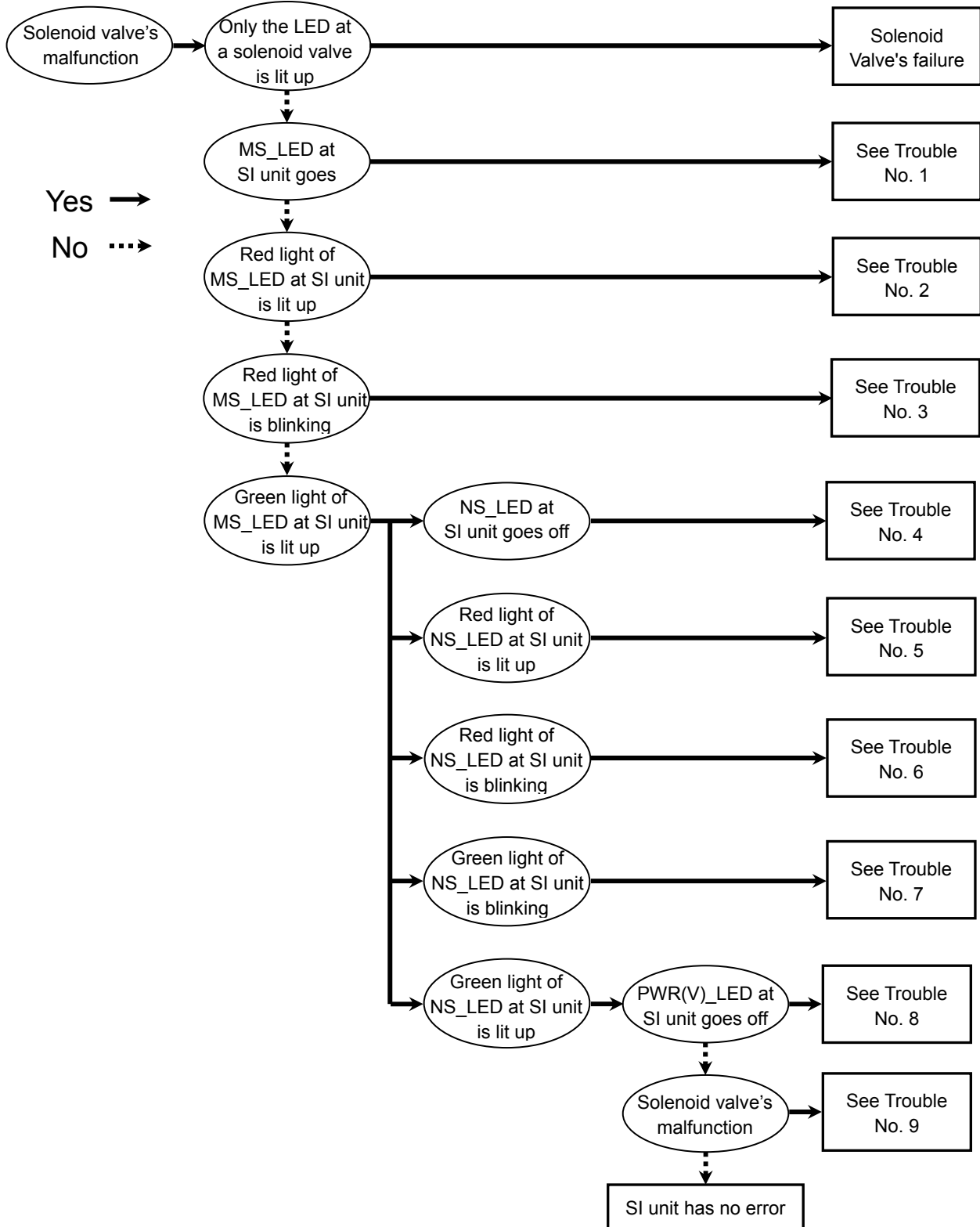



●List of Troubles and Countermeasures

Trouble No.	Problem	Possible cause	Investigation method	Countermeasure
1	MS_LED at SI unit goes off	Failure of wiring	Check the communication power supply cable is not opened, and that there are no loose connections between the power supply cable and terminal. Check there is no repeated bending and pulling force applied to the cable, which will cause breakage.	Connect the power supply cable correctly.
		Failure in power supply	Check proper wiring of communication power supply.	Correct the wiring.
			Check the supply voltage to the power supply	Supply 14 VDC to 26.4 VDC to the power supply for SI unit.
2	Red light of MS_LED at SI unit is lit up	Failure in SI unit	The product has failed.	Replace the SI unit with a new one.
3	Red light of MS_LED of SI unit is blinking	Incorrect setting of node address	Check there is no mistake with the set node address.	Set correctly.
4	SI unit MS_LED green on NS_LED goes off	Master unit power supply failure	Check the master unit is operating properly.	Connect the master unit to a proper power supply.
5	SI unit MS_LED green on NS_LED red on	Duplication of node address	Check the set node address is not duplicated by other slave units.	Set correctly.
6	SI unit MS_LED green on NS_LED red blinking	Communication timeout	Check the communication cable is not opened, and that there are no loose connections between the power supply cable and terminal. Check there is no repeated bending and pulling force applied to the cable, which will cause breakage.	Connect the communication cable correctly.
			Check proper wiring of communication cable.	Correct the wiring.
			Check the terminal resistance (121 Ω) is installed only at both ends of the main line.	Install the terminal resistance (121 Ω) properly.
			Check proper length of the cable (main line and branch line).	Correct the wiring.
			Check the existence of equipment and high voltage line, which cause noise, around the communication and power supply lines.	Separate the cables for communication and power from the noise sources.
			Check that all slaves are properly set.	Correct the wiring.

Trouble No.	Problem	Possible cause	Investigation method	Countermeasure
7	SI unit MS_LED green on NS_LED green blinking	Connecting	Check the master unit is operating properly.	Refer to the Operation Manual of the master unit.
			Check the I/O area of the slave unit is not over the area permitted by the master unit.	
8	SI unit MS_LED green on NS_LED green on PWR(V)_LED goes off	Incorrect wiring of valve power supply	Check the valve power supply cable is not opened, and that there are no loose connections between the power supply cable and terminal. Check there is no repeated bending and pulling force applied to the cable, which will cause breakage.	Connect the valve power supply cable correctly.
		Valve power supply failure	Check there is no incorrect wiring of valve power supply.	Correct the wiring.
			Check proper supply voltage of valve power supply.	Supply 24 VDC -5% +10% to valve communication power supply.
9	Valve malfunction	Valve failure	Check the operation with another valve.	Check the troubleshooting for a valve.
		Connection failure between SI unit and manifold.	Check the connector between SI unit and manifold for the connection failure such as a bent pin	Correct the connection between SI unit and manifold.
		Valves over a total of 16 outputs will not operate.	Check the total number of outputs of the valves connected to the manifold is 16 or less.	The max. number of outputs of the product is 16. Be sure to keep the number of outputs 16 or less.

# Specifications

## ■ Specifications

### ● Unit specifications

Model		EX12#-SCM1	EX12#-SCM3
Power supply voltage	For unit	14 to 26.4 VDC	
	For valve	24 VDC +10%/-5% *1	
Internal current consumption (unit)		100 mA or less	
Output specification	Output type (Valve common polarity)	Sink/NPN (Positive common)	Source/PNP (Negative common)
	Output points	16 points	
	Connection load	24 VDC Solenoid valve with a surge voltage suppressor of 2.1 W or less, made by SMC	
	Output of communication error	Hold/Clear (set through network)	
Environment proof	Enclosure	IP20	
	Operating temperature range	0 to 55 °C (8 valves on) 0 to 50 °C (16 valves on)	
	Operating humidity range	35 to 85%RH (no dew concentration)	
	Withstand voltage	1000 VAC, 1 min. Between external terminals and body	
	Insulation resistance	500 VDC, 2 MΩ or more Between external terminals and body	
	Operating environment	No corrosive gas and no dust	
	Pollution degree	Pollution degree 3 *2	
Standard		CE marking	
Weight		EX120-SCM#: 100 g or less EX121-SCM#: 120 g or less EX122-SCM#: 110 g or less } (Contain the accessories)	
Accessory		Power supply connector 1 pc. (EX9-CP2)	

\*1: The condition for allowable voltage fluctuation to solenoid valve is 24 VDC±10%.

Please confirm the allowable voltage fluctuation range of solenoid valve that is installed in SI unit and set the power supply voltage in consideration of Max. 5% voltage drop across SI unit.

\*2: This product is IP20 rated.

When operating this product in a pollution degree 3 environment, mount it onto an IP54 rate or higher controller board etc.

### ● Communication specifications

Model	Specifications
Protocol	CompoNet™
Communication speed	93.75 kbps/1.5 Mbps/3 Mbps/4 Mbps
Setting file	EDS file (downloaded from our web site)
Occupied area (No. of input/output)	0/16

■Dimensions (unit: mm)

●EX120-SCM#

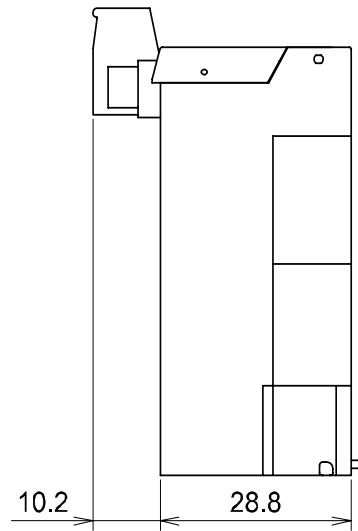
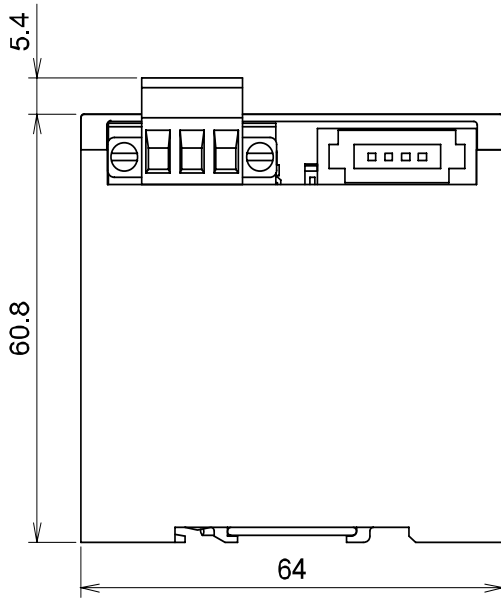
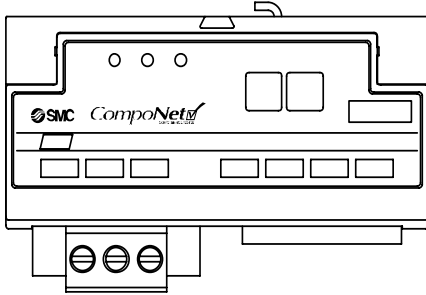

●EX121-SCM#

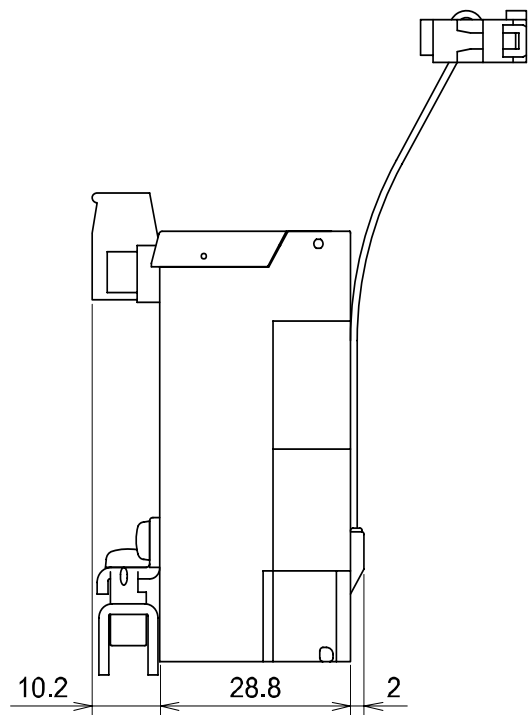
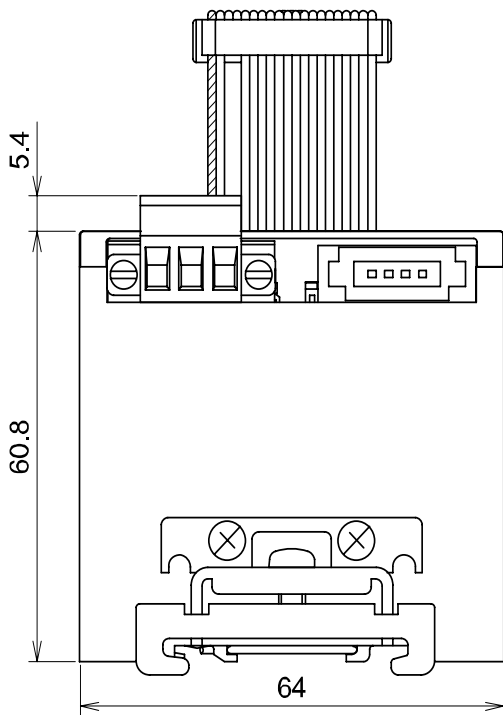
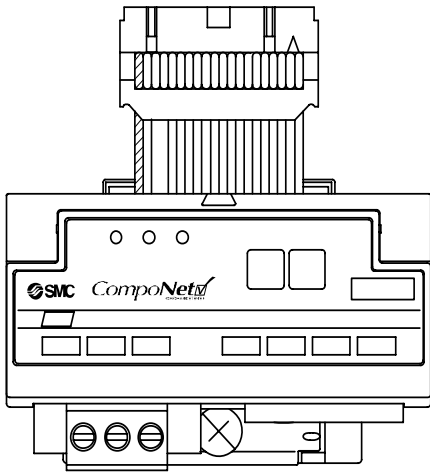

●EX122-SCM#

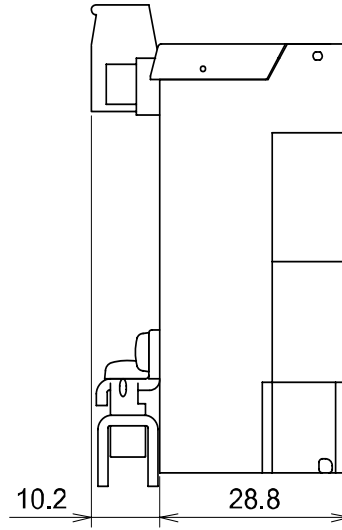
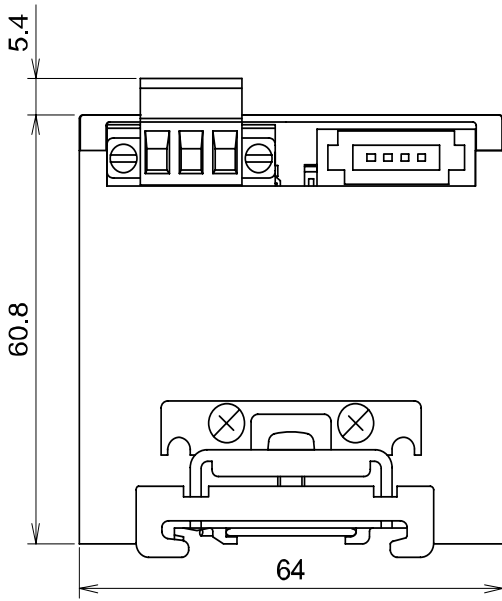
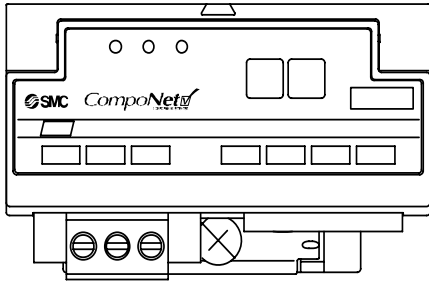

Revision history
A: Add the contents.
B: Revision.
C: Add the contents.

## SMC Corporation

4-14-1, Sotokanda, Chiyoda-ku, Tokyo 101-0021 JAPAN  
Tel: +81 3 5207 8249 Fax: +81 3 5298 5362  
URL <http://www.smcworld.com>

---

Note: Specifications are subject to change without prior notice and any obligation on the part of the manufacturer.  
CompoNet™ is a trademark of ODVA.  
© 2009-2012 SMC Corporation All Rights Reserved

