



Operation Manual

PRODUCT NAME

Regulator

MODEL / Series / Product Number

IR1200-A

IR1210-A

IR1220-A

Contents

Safety Instructions	1 to 5
1. Application	6
2. Specifications	6
3. Construction and Operation Principles	7
4. How to order	8
5. Bracket, gauge and switch assembly (optional)	9
6. Panel mounting	10
7. Troubleshooting	11
8. Dimensions	12



Safety Instructions

These safety instructions are intended to prevent hazardous situations and/or equipment damage. These instructions indicate the level of potential hazard with the labels of “Caution,” “Warning” or “Danger.” They are all important notes for safety and must be followed in addition to International Standards (ISO/IEC)*1), and other safety regulations.

*1) ISO 4414: Pneumatic fluid power -- General rules relating to systems.

ISO 4413: Hydraulic fluid power -- General rules relating to systems.

IEC 60204-1: Safety of machinery -- Electrical equipment of machines .(Part 1: General requirements)

ISO 10218-1992: Manipulating industrial robots -Safety.

etc.



Caution

Caution indicates a hazard with a low level of risk which, if not avoided, could result in minor or moderate injury.



Warning

Warning indicates a hazard with a medium level of risk which, if not avoided, could result in death or serious injury.



Danger

Danger indicates a hazard with a high level of risk which, if not avoided, will result in death or serious injury.

Warning

1. The compatibility of the product is the responsibility of the person who designs the equipment or decides its specifications.

Since the product specified here is used under various operating conditions, its compatibility with specific equipment must be decided by the person who designs the equipment or decides its specifications based on necessary analysis and test results. The expected performance and safety assurance of the equipment will be the responsibility of the person who has determined its compatibility with the product. This person should also continuously review all specifications of the product referring to its latest catalog information, with a view to giving due consideration to any possibility of equipment failure when configuring the equipment.

2. Only personnel with appropriate training should operate machinery and equipment.

The product specified here may become unsafe if handled incorrectly. The assembly, operation and maintenance of machines or equipment including our products must be performed by an operator who is appropriately trained and experienced.

3. Do not service or attempt to remove product and machinery/equipment until safety is confirmed.

1. The inspection and maintenance of machinery/equipment should only be performed after measures to prevent falling or runaway of the driven objects have been confirmed.

2. When the product is to be removed, confirm that the safety measures as mentioned above are implemented and the power from any appropriate source is cut, and read and understand the specific product precautions of all relevant products carefully.

3. Before machinery/equipment is restarted, take measures to prevent unexpected operation and malfunction.

4. Contact SMC beforehand and take special consideration of safety measures if the product is to be used in any of the following conditions.

1. Conditions and environments outside of the given specifications, or use outdoors or in a place exposed to direct sunlight.

2. Installation on equipment in conjunction with atomic energy, railways, air navigation, space, shipping, vehicles, military, medical treatment, combustion and recreation, or equipment in contact with food and beverages, emergency stop circuits, clutch and brake circuits in press applications, safety equipment or other applications unsuitable for the standard specifications described in the product catalog.

3. An application which could have negative effects on people, property, or animals requiring special safety analysis.

4. Use in an interlock circuit, which requires the provision of double interlock for possible failure by using a mechanical protective function, and periodical checks to confirm proper operation.



Safety Instructions

Caution

1. The product is provided for use in manufacturing industries.

The product herein described is basically provided for peaceful use in manufacturing industries. If considering using the product in other industries, consult SMC beforehand and exchange specifications or a contract if necessary.
If anything is unclear, contact your nearest sales branch.

Limited warranty and Disclaimer/Compliance Requirements

The product used is subject to the following “Limited warranty and Disclaimer” and “Compliance Requirements”.

Read and accept them before using the product.

Limited warranty and Disclaimer

1. The warranty period of the product is 1 year in service or 1.5 years after the product is delivered, whichever is first. *2)

Also, the product may have specified durability, running distance or replacement parts. Please consult your nearest sales branch.

2. For any failure or damage reported within the warranty period which is clearly our responsibility, a replacement product or necessary parts will be provided.

This limited warranty applies only to our product independently, and not to any other damage incurred due to the failure of the product.

3. Prior to using SMC products, please read and understand the warranty terms and disclaimers noted in the specified catalog for the particular products.

***2) Vacuum pads are excluded from this 1 year warranty.**

A vacuum pad is a consumable part, so it is warranted for a year after it is delivered.

Also, even within the warranty period, the wear of a product due to the use of the vacuum pad or failure due to the deterioration of rubber material are not covered by the limited warranty.

Compliance Requirements

1. The use of SMC products with production equipment for the manufacture of weapons of mass destruction(WMD) or any other weapon is strictly prohibited.

2. The exports of SMC products or technology from one country to another are governed by the relevant security laws and regulation of the countries involved in the transaction. Prior to the shipment of a SMC product to another country, assure that all local rules governing that export are known and followed.

Operating Environment

Warning

- ① Do not use in an atmosphere containing corrosive gases, chemicals, organic solvent, sea water, water, water steam, or where there is direct contact with any of these.
- ② Do not operate in environments subject to heavy vibration and/or impact.
- ③ The regulator should not be exposed to prolonged sunlight. If used in direct sunlight, a protective cover should be used.
- ④ Do not install close to heat sources. If installed, protect the product against radiated heat from source adequately.
- ⑤ Install suitable protective measures in locations where there is contact with water drop- lets, oil or welding spatter, etc.

Handling Precautions

Caution

- ① Do not use a precision regulator outside of the range of its specifications as this can cause failure.
- ② Be sure to confirm the port indication when installing the product.
- ③ When mounting the bracket or tightening the hexagon panel nut on the panel, tighten them to the recommended tightening torque.
Insufficient tightening torque can cause loose piping. Excessive tightening torque can cause thread damage.

Recommended tightening torque [N-m]

Set nut (for bracket)	1.8 to 2.2
Hexagon panel net (handle type only)	3 to 4

- ④ Adjust the pressure by increasing the pressure. After pressure adjustment, be sure to tighten the lock nut. When tightening the nut, tighten so that the handle does not move due to friction caused by tightening.
The outlet pressure may become lower than set pressure if adjusted by decreasing the pressure. Turning the handle clockwise increases the outlet pressure, and turning it counterclockwise reduces the pressure.
- ⑤ When pressure is applied to the inlet of a regulator, make sure that the outlet port is connected to the circuit. Air blow occurs from the outlet and it depends on the operating conditions.
- ⑥ The set pressure may vary depending on the elapsed time and change in ambient temperature after pressure setting. If the setting value varies, adjust with the handle.
- ⑦ If the directional control valve (solenoid valve, mechanical valve etc.) is mounted and ON-OFF is repeated for a long time, the set pressure may vary. If the setting value varies, adjust with the handle.
- ⑧ There may be pulsation or noise depending on the pressure conditions, piping conditions and ambient environment. In this case, it is possible to improve the problem by changing the pressure conditions and piping conditions.
If the problem is not improved, contact your SMC sales representative.
- ⑨ There is no connection thread on the exhaust port. If it is necessary to mount a silencer to the exhaust port, please contact your SMC sales representative.
- ⑩ When a pressure gauge is mounted to the regulator, please do not exceed the maximum display pressure. It may lead to a malfunction.
- ⑪ A safety device needs to be installed if output pressure is exceeding the set pressure, otherwise this can cause the breakage of outlet device and equipment or malfunction.

Piping

Warning

- ① **Connect piping/fittings using the recommended torque while holding the product tightly.** Looseness or faulty sealing will occur if tightening torque is insufficient, while thread damage will result if the torque is excessive. Furthermore, if the side with the female threads is not held while tightening, excessive force will be applied directly to piping brackets, etc. causing damage or other problems.

Recommended tightening torque [N-m]

Thread	1/8
Torque	7 to 9

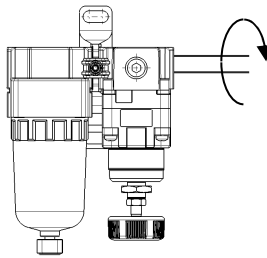

- ② **Do not apply any additional twisting, or bending moments except for the weight of the filter regulator itself.**

Provide separate support for external piping, as damage may otherwise occur.

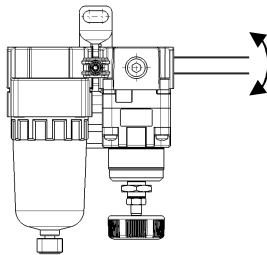

- ③ **Non-flexible piping materials such as steel piping will be subject to excessive moment load and vibration from the piping side, so use a flexible tube for intermediate connections.**

Caution

① Preparation before piping

Before piping is connected, it should be thoroughly blown out with air (flushing) or washed to remove chips, cutting oil and other debris from inside the pipe.

② Wrapping of sealant tape

When screwing piping or fittings into ports, ensure that metal chips from the pipe threads or sealing material do not enter the piping.

Furthermore, when pipe tape is used, leave 1.5 to 2 thread ridges exposed at the end of the threads.

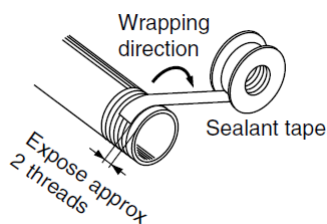

Handling



Caution

- ① **When the precision regulator with pressure gauge is used, do not apply impact to the product by dropping it etc. during transportation or installation.**

This may cause misalignment of the pressure gauge pointer.

Air Supply



Warning

- ① **The operating fluid must be compressed air. Contact SMC if using the product with other fluids.**
- ② **Do not use compressed air that contains chemicals, synthetic oils including organic solvents, salts or corrosive gases etc., as this can cause damage or malfunction.**
- ③ **If condensate in the drain bowl is not emptied on a regular basis, the bowl will overflow and allow the condensate to enter the outlet side. This will cause a malfunction of pneumatic equipment downstream of regulator.**

If the drain bowl is difficult to check and remove, installation of a drain bowl with an auto drain option is recommended.



Caution

- ① **Condensate or dust, etc. in the supply pressure line can cause malfunctions. Please use an air filter (SMC series AF etc.) or mist separator (SMC AM, AFM series).**
Refer to "Air Preparation Equipment Model Selection Guide" (Best Pneumatics No. 5) for model selection based on air quality.
- ② **When a lubricator is used at the supply side of the product, it can cause malfunctions. Do not use a lubricator at the supply side of the product.**

If lubrication is required for terminal devices, connect a lubricator on the output side of the regulator.

Maintenance



Warning

- ① **When the product is removed for maintenance, reduce the set pressure to zero and shut off the supply pressure completely beforehand.**
- ② **When connecting an additional pressure gauge, the set pressure should be reduced to zero before removing the plug.**
- ③ **When using the regulator between a solenoid valve and an actuator, check the pressure gauge periodically.**

Sudden pressure fluctuations may shorten the durability of the pressure gauge. A digital pressure gauge is recommended for such situation applications or as deemed necessary.

1 . Application

This instrument aims at controlling pressure of air lines.

2 . Specifications

Model	IR1200	IR1210-A	IR1220-A
Max. supply pressure [MPa]	1.0		
Min. supply pressure [MPa] ^(Note 1)	Set pressure + 0.05		
Set pressure range [MPa]	0.02 to 0.2	0.02 to 0.4	0.02 to 0.8
Repeatability ^(Note 3)	^(Note 2) within +/- 1.0% of the full span (F.S.)		
Ambient temp. and Fluid temperature [°C]	Standard product: -5 to 60 With digital pressure switch: 0 to 50 (No freezing)		
Port size	1/8		
Pressure gauge port size	1/8 [2 ports]		
Weight [kg]	^(Note 4) 0.13		

(Note 1) When there is no flow rate on the outlet side. Maintain the minimum supply pressure (set pressure + 0.05MPa).

(Note 2) Full span indicates the maximum set pressure of the product. (e.g.IR1200-A: 0.2MPa)

(Note 3) Other characteristics such as aging deterioration and temperature characteristics are not included.

(Note 4) Excluding accessories.

3. Construction and Operation Principles

When the knob is rotated, the flapper is pushed through the spring, and a gap is generated between the nozzle and flapper. The supply pressure flows to the inlet passes through the path between the nozzle and flapper and acts on the supply diaphragm as nozzle pressure. The force generated by the diaphragm pushes down the valve, and the supply pressure flows to the outlet. The discharged air pressure acts on the exhaust diaphragm, and counteracts against the force generated by the supply diaphragm. The air pressure acts on the nozzle diaphragm at the same time, and counteracts against the compression force of the adjusting spring to adjust the set pressure. When the set pressure increases too much, the nozzle diaphragm is pushed up, and a gap is generated between the flapper and nozzle diaphragm. This happens after the flapper closes. The balance of the supply diaphragm and exhaust diaphragm is lost when the nozzle back pressure flows into the atmosphere. The exhaust valve is open after the valve is closed, and excess pressure on the outlet is released to the air. Due to this pilot mechanism, fine pressure variations are detected and precise pressure adjustment is possible.

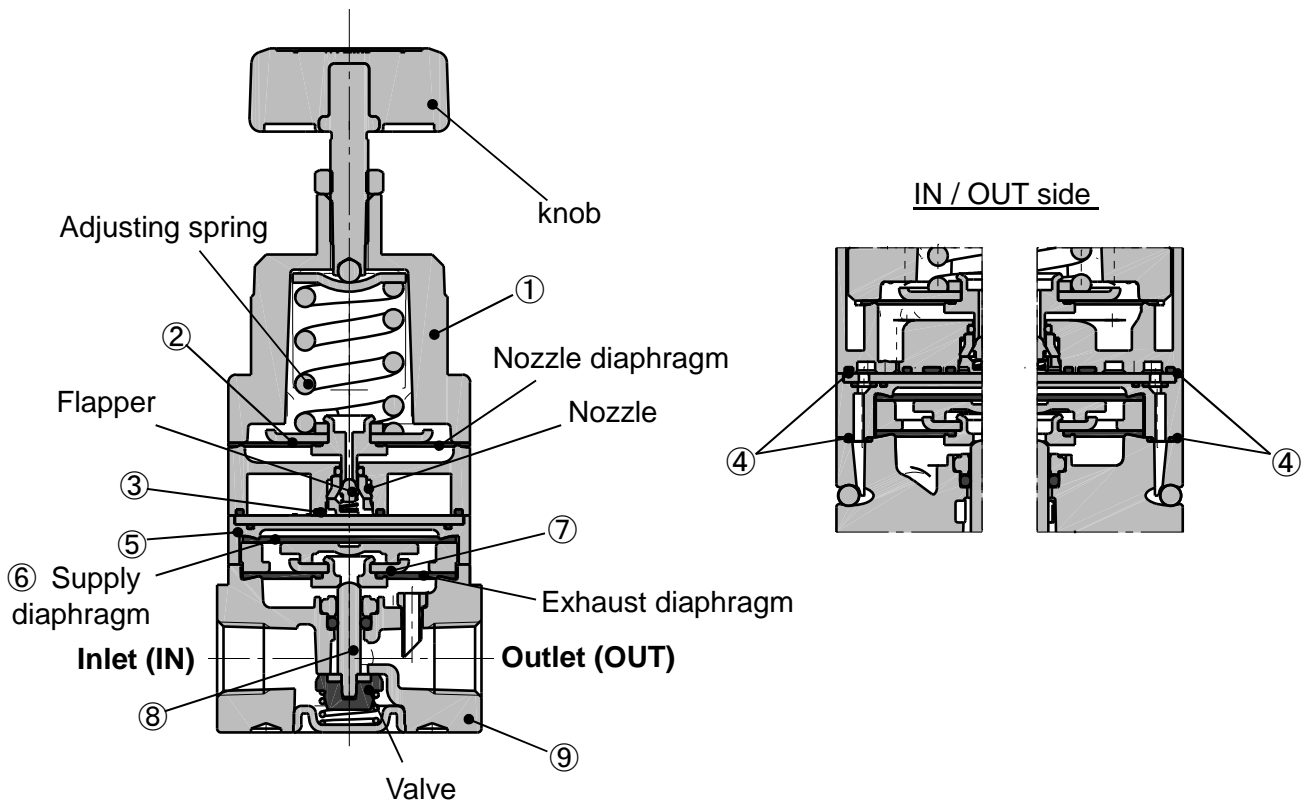

Component parts

No.	Description	Materials
①	Bonnet	Aluminum die-cast
②	Nozzle diaphragm assembly	Aluminum, Weather resistant NBR
③	Seal	HNBR
④	Seal	NBR
⑤	Diaphragm spacer	Polyacetal
⑥	Supply diaphragm	Weather resistant NBR
⑦	Exhaust diaphragm assembly	Aluminum, Weather resistant NBR
⑧	Valve assembly	Aluminum, stainless steel, HNBR
⑨	Body	Aluminum die-cast

Grease: lithium grease

4. How to order

IR 1 2 0 0 — 01 BG — — A

1
2
3
4
5
6

- Option/Semi-standard: Select one each for a to e.
- Option/Semi-standard symbol: When more than one specification is required, indicate in alphanumeric order.

		Symble	Description				
1	Set pressure range	0	0.02~0.2MPa				
		1	0.02~0.4MPa				
		2	0.02~0.8MPa				
+							
2	Exhaust direction	0	Bottom exhaust				
+							
3	Pipe thread type	Nil	Rc				
		N	NPT				
		F	G				
+							
4	Port size	01	1/8				
+							
5	Option <small>Note1)</small>	a	Mounting	Nil	Without pressure gauge		
				B	With bracket		
				H	With hexagon panel nut (for panel mount)		
	+						
	b	With digital pressure switch	Nil	Without pressure gauge			
			G	Round type pressure gauge			
			EA	NPN open collector 1 output			
			EB	PNP open collector 1 output			
			EC	NPN open collector 1 output + Analog voltage output			
	ED	NPN open collector 1 output + Analog current output					
+							
6	Semi-standard	c	Flow direction	Nil	Flow direction : Left to right		
				R	Flow direction : Right to left		
		+					
		d	Knob	Nil	Upward		
				V	Downward		
		+					
e	Pressure unit <small>Note2)</small>	Nil	Name plate and pressure gauge in imperial unit : MPa				
		Z	Name plate and pressure gauge in imperial unit : psi				
		ZA	Digital pressure switch : With unit conversion function				

Note1) Option are shipped together with the product, but not assembled. B and H cannot be select at the same time.

The current bracket cannot be used for this product.

Assembly of a bracket and set nuts.

Note2) See pressure unit table below.

	Pipe thread type	Name plate in imperial units	pressure gauge in imperial units		Sales Note5)
			G	EA, EB, EC, ED	
Nil	Rc	MPa	MPa	Fixed SI unit	Japan, Overseas
	NPT				
	G				
Z <small>注3)</small>	Rc	-	-	-	Only overseas
	NPT	psi	psi	With unit conversion function (Initial value : psi)	
	G	-	-	-	
ZA <small>注4)</small>	Rc	MPa	-	With unit conversion function	Only overseas
	NPT				
	G				

Note3) For pipe thread type : NPT

Note4) For options : EA, EB, EC, ED

Note5) According to the new Measurement Law, only the SI unit type is provided for use in Japan.

5. Bracket, gauge and switch assembly (optional)

1. Bracket

1) Installation of bracket
Mount the bracket to the regulator as shown on the picture. Assemble so that the regulator and rotation stopper of the bracket align properly.

2) Holding with the set nut
Insert the set nut into the bonnet of the regulator so that the knurled tool face of the set nut will face the upper surface of the bracket. It is recommended that the set nut is tightened securely by hand.

*** When retightening**
Please use hook spanner on hook groove of the set nut, and tighten. Please follow the table below for hand tightening and retightening.

Tool size [mm]	Reference torque [N-m]
34/38	1.8 to 2.2

2. Round type pressure gauge, digital pressure switch

1) Instruction for mounting of the round type pressure gauge and digital pressure switch
Confirm that sealant is applied to the round type pressure gauge and digital pressure switch. Mount them into the chosen pressure gauge connection port. Please refer to "Piping" on page 5 when using sealant tape.

*** Position adjustment of the round type pressure gauge and digital pressure switch**
Adjust the round type pressure gauge by tightening the thread. Do not unscrew the gauge as air leakage may occur.

*** Position adjustment of the pressure gauge and digital pressure switch on the back of the regulator**
The pressure gauge connection port on the front of the regulator with round type pressure gauge and digital pressure switch is not plugged. When mounting the round type pressure gauge or digital pressure switch on the back of the regulator, please remove the plug on the back and mount it at the front.

Part name	Tools	Tool size [mm]	Recommended torque [N-m]
Plug	Hexagon wrench key	4	0.55 to 0.65
Round type pressure gauge	Wrench	10	7 to 9
Digital pressure switch	Wrench	12	7 to 9

6. Panel mounting

1. Panel mounting

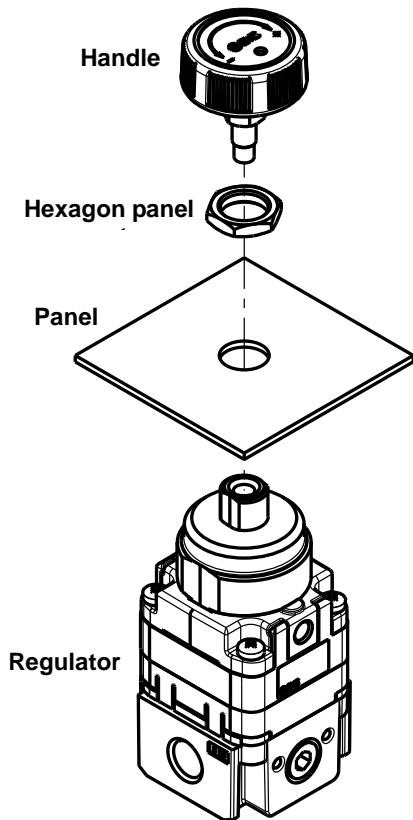

1) Handle removal

Remove the handle from the regulator.

2) Panel mounting

Insert the regulator into the panel.

3) Nut tightening

Adjust the regulator position and tighten the attached hexagon panel nut.

Recommended tightening torque

Wrench size [mm]	Tightening Torque[N-m]
14	3 to 4

4) Handle mounting

Mount the handle back onto the regulator.

* **Excessive tightening of the handle may cause excessive pressure on the outlet side when supplying pressure.**

* Recommended panel dimension

Panel hole diameter [mm]	Panel thickness [mm]
$\phi 10.5$	4 or less

7. Troubleshooting

No.	Problem	Possible causes	Countermeasures	
1	Reduction of the set pressure	Fluctuation of flow rate at the downstream side	Set the pressure again. Return the flow rate at the downstream side to the initial rate.	
		Leakage due to deterioration of the rubber part.	Ozone	Use the ozone resistant product (80- series).
			Temperature	Avoid using at high temperature or low temperature.
			Organic solvent etc.	Take countermeasures to prevent organic solvent from the ambient atmosphere or fluid.
		High frequency ON-OFF operation on the downstream side.	Set the pressure again.	
Pressure in the bonnet is reduced.	Release the pressure in the bonnet which is the reference pressure to the atmosphere.			
2	The set pressure increases or decreases as time passes.	Aging deterioration of the regulator	Set the pressure again.	
3	Increased leakage from the bonnet breathing hole and exhaust port	Leakage due to deterioration of the rubber part.	Ozone	Use the ozone resistant product (80- series).
			Temperature	Avoid using at high temperature or low temperature.
			Organic solvent etc.	Take countermeasures to prevent organic solvent from the ambient atmosphere or fluid.
		Foreign matter caught in the seat	Install a filter or mist separator to clean the air supply.	
			Perform flushing by releasing the downstream side to atmosphere.	
4	The set pressure changes periodically.	Supply pressure fluctuates.	Install the regulator on the front to reduce the fluctuation.	
		Ambient temperature and fluid temperature change	Take countermeasures to prevent temperature changes.	
5	Pressure does not increase.	Insufficient min. supply pressure	Increase the supply pressure.	
6	Repeatability accuracy is bad.	Due to problem 1.	Refer to problem 1.	
		Due to problem 2.	Refer to problem 2.	
7	Oscillation occurs.	Leakage from the downstream side.	Prevent the leakage from the piping.	
		Downstream piping condition	Oscillation occurs depending on the condition. In that case, please contact your SMC sales representative.	
8	There is leakage from the ports other than the bonnet breathing hole and exhaust port.	Leakage due to deterioration of the rubber part.	Consult SMC.	

※ If any of the troubleshooting is not applicable, please contact your SMC sales representative.

8. Dimensions

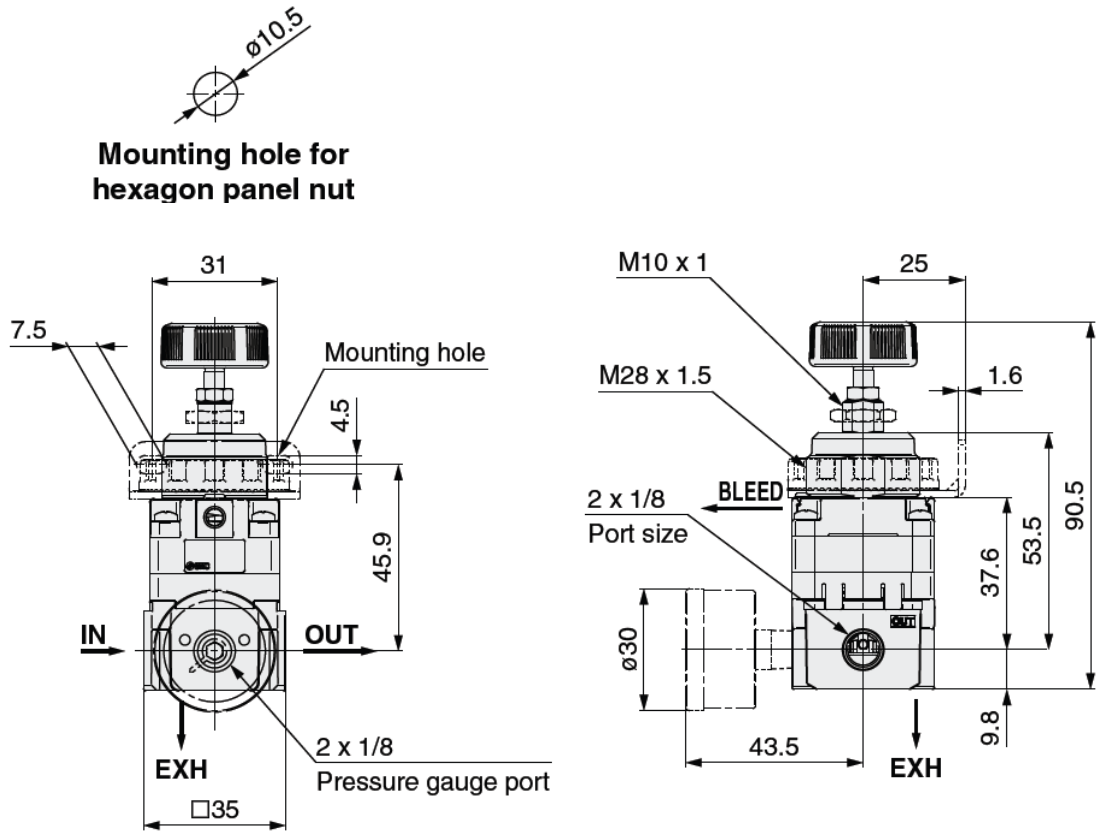

With digital pressure switch:

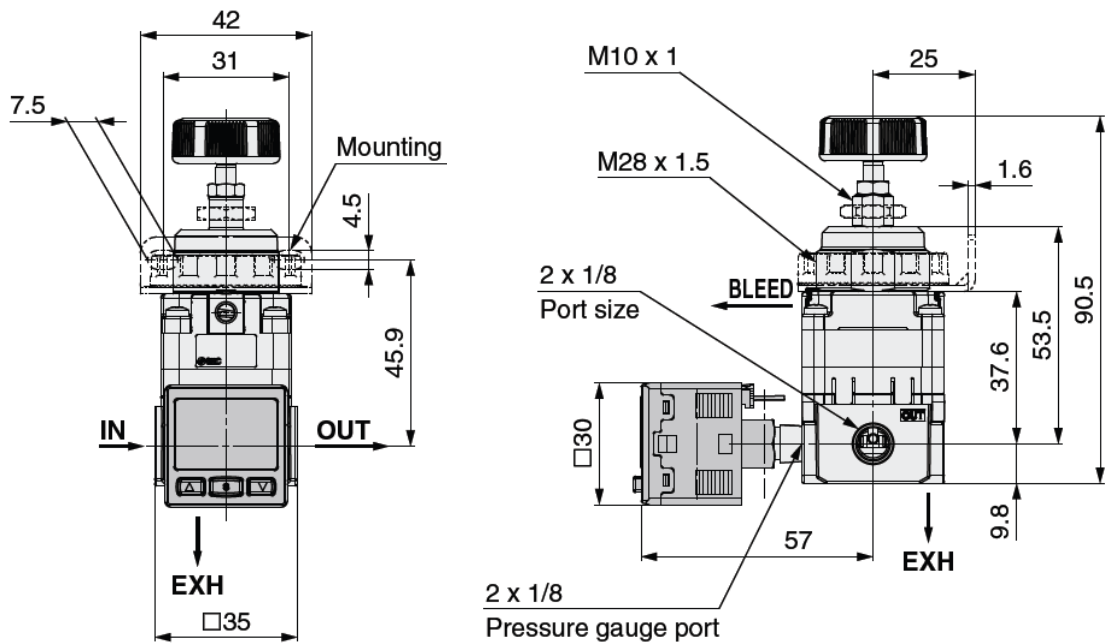

Revision history

SMC Corporation

4-14-1, Sotokanda, Chiyoda-ku, Tokyo 101-0021 JAPAN

Tel: + 81 3 5207 8249 Fax: +81 3 5298 5362

URL <http://www.smcworld.com>

Note: Specifications are subject to change without prior notice and any obligation on the part of the manufacturer.
© 2011 SMC Corporation All Rights Reserved

