



Operation Manual

PRODUCT NAME

S Couplers

MODEL / Series / Product Number

KKA Series

SMC Corporation

Contents

1. Safety Instructions -----	2-11
2. Specifications -----	12
3. Troubleshooting -----	12
4. Construction -----	13
5. Spare Parts -----	14



Safety Instructions

These safety instructions are intended to prevent hazardous situations and/or equipment damage. These instructions indicate the level of potential hazard with the labels of “Caution,” “Warning” or “Danger.” They are all important notes for safety and must be followed in addition to International Standards (ISO/IEC)*1), and other safety regulations.

*1) ISO 4414: Pneumatic fluid power -- General rules relating to systems.

ISO 4413: Hydraulic fluid power -- General rules relating to systems.

IEC 60204-1: Safety of machinery -- Electrical equipment of machines .(Part 1: General requirements)

ISO 10218: Manipulating industrial robots -Safety.

etc.



Caution

Caution indicates a hazard with a low level of risk which, if not avoided, could result in minor or moderate injury.



Warning

Warning indicates a hazard with a medium level of risk which, if not avoided, could result in death or serious injury.



Danger

Danger indicates a hazard with a high level of risk which, if not avoided, will result in death or serious injury.

Warning

1. The compatibility of the product is the responsibility of the person who designs the equipment or decides its specifications.

Since the product specified here is used under various operating conditions, its compatibility with specific equipment must be decided by the person who designs the equipment or decides its specifications based on necessary analysis and test results.

The expected performance and safety assurance of the equipment will be the responsibility of the person who has determined its compatibility with the product.

This person should also continuously review all specifications of the product referring to its latest catalog information, with a view to giving due consideration to any possibility of equipment failure when configuring the equipment.

2. Only personnel with appropriate training should operate machinery and equipment.

The product specified here may become unsafe if handled incorrectly.

The assembly, operation and maintenance of machines or equipment including our products must be performed by an operator who is appropriately trained and experienced.

3. Do not service or attempt to remove product and machinery/equipment until safety is confirmed.

1. The inspection and maintenance of machinery/equipment should only be performed after measures to prevent falling or runaway of the driven objects have been confirmed.

2. When the product is to be removed, confirm that the safety measures as mentioned above are implemented and the power from any appropriate source is cut, and read and understand the specific product precautions of all relevant products carefully.

3. Before machinery/equipment is restarted, take measures to prevent unexpected operation and malfunction.

4. Contact SMC beforehand and take special consideration of safety measures if the product is to be used in any of the following conditions.

1. Conditions and environments outside of the given specifications, or use outdoors or in a place exposed to direct sunlight.

2. Installation on equipment in conjunction with atomic energy, railways, air navigation, space, shipping, vehicles, military, medical treatment, combustion and recreation, or equipment in contact with food and beverages, emergency stop circuits, clutch and brake circuits in press applications, safety equipment or other applications unsuitable for the standard specifications described in the product catalog.

3. An application which could have negative effects on people, property, or animals requiring special safety analysis.

4. Use in an interlock circuit, which requires the provision of double interlock for possible failure by using a mechanical protective function, and periodical checks to confirm proper operation.



Safety Instructions

Caution

The product is provided for use in manufacturing industries.

The product herein described is basically provided for peaceful use in manufacturing industries.

If considering using the product in other industries, consult SMC beforehand and exchange specifications or a contract if necessary.

If anything is unclear, contact your nearest sales branch.

Limited warranty and Disclaimer/Compliance Requirements

The product used is subject to the following “Limited warranty and Disclaimer” and “Compliance Requirements”.

Read and accept them before using the product.

Limited warranty and Disclaimer

1. The warranty period of the product is 1 year in service or 1.5 years after the product is delivered, whichever is first.*2)

Also, the product may have specified durability, running distance or replacement parts. Please consult your nearest sales branch.

2. For any failure or damage reported within the warranty period which is clearly our responsibility, a replacement product or necessary parts will be provided.

This limited warranty applies only to our product independently, and not to any other damage incurred due to the failure of the product.

3. Prior to using SMC products, please read and understand the warranty terms and disclaimers noted in the specified catalog for the particular products.

*2) Vacuum pads are excluded from this 1 year warranty.

A vacuum pad is a consumable part, so it is warranted for a year after it is delivered.

Also, even within the warranty period, the wear of a product due to the use of the vacuum pad or failure due to the deterioration of rubber material are not covered by the limited warranty.

Compliance Requirements

1. The use of SMC products with production equipment for the manufacture of weapons of mass destruction(WMD) or any other weapon is strictly prohibited.

2. The exports of SMC products or technology from one country to another are governed by the relevant security laws and regulation of the countries involved in the transaction. Prior to the shipment of a SMC product to another country, assure that all local rules governing that export are known and followed.

Caution

SMC products are not intended for use as instruments for legal metrology.

Measurement instruments that SMC manufactures or sells have not been qualified by type approval tests relevant to the metrology (measurement) laws of each country.

Therefore, SMC products cannot be used for business or certification ordained by the metrology (measurement) laws of each country.

Selection

Warning

- (1) Check the specifications.
Do not use the product outside of the specified pressure and temperature range, as this may cause breakage or operation failure. (Refer to the specifications.)
SMC does not guarantee against any damage if the product is used outside of the specification range.
- (2) Disassembly and modification prohibited
Do not disassemble the product or make any modifications, including additional machining. This may cause human injury and/or an accident.
- (3) Check if PTFE is compatible with application.
The sealing agent applied to the threads includes PTFE (polytetrafluoroethylene) powder. Check whether or not it could cause issues in your application.
- (4) The product cannot be used as a stop valve to achieve zero leakage. A certain amount of leakage is allowed in the product specifications.
- (5) The KKA series cannot be connected to SMC's KK, KKH, KK13 or KK130 series or other manufacturer's quick couplers. This will cause leakage, damage, and disconnection of the plug. Check the specifications before use.
- (6) Do not connect or remove the product while it is pressurized or residual pressure remains. The pressure can cause disconnection.
- (7) Never pressurize the coupler without check valve in disconnecting condition. The connected pipings may break loose, causing danger.
- (8) The coupler without check valve leaks fluid in the piping when it is disconnected. Be careful especially when fluid which may cause danger, such as fluid with high temperature and pressure, is used. In such cases, we strongly recommend using a product with a stop valve.
- (9) The product will become hot if used with a high temperature fluid. If the hot product comes into contact with peripheral equipment or parts, it may cause fire.
Please attach and detach the plug and socket after keeping the normal temperature.

Caution

- (1) For a plug and socket connection, select a plug and socket with the same body size.
If their body sizes are different, they cannot be connected. This will cause leakage, damage, and disconnection of the plug. Inserting anything other than the special plug into the socket may cause the product failure.
- (2) Do not use in a location where the connecting threads and tubing connection will oscillate or rotate. Oscillation or rotation will disconnect the tubing from the thread.
- (3) Do not use the product with flammable, explosive, or toxic substances such as gas, gas fuel, and refrigerants. Such substances may permeate from inside to outside of the tubing.

(4) Surge pressure must be under the maximum operating pressure.

If the surge pressure exceeds the maximum operating pressure, it will result in damage to fittings and tubings.

(5) Do not use the product with steam.

The metallic parts may be corroded or the sealant may be deteriorated if the product is used with steam for an extended period of time.

Mounting

Warning

(1) Install and operate the product only after reading the Operation Manual carefully and understanding its contents.

Also, keep the manual where it can be referred to as necessary.

(2) Maintenance space

Allow sufficient space for maintenance and inspection.

(3) Tightening of screws

Refer to “Handling Precautions for screw piping” (page 11).

(4) Tubings can become unsecured and break loose while the product is in use, due to the deterioration of the tubing or damage to the fitting. To prevent the tubing from breaking loose, install a protective cover or fix the tubing.

(5) Do not use the product where rotation normally occurs. Otherwise, the product may be damaged.

(6) Avoid applications in which vibration or shock is directly applied to the product.

(7) Install a stop valve on the supply pressure side of the socket. Otherwise, it may not be possible to perform an emergency shutoff.

(8) The plug should be upright to the socket when connected.

Inclined connection can damage the plug and socket.

Caution

(1) Preparation before piping

Before piping is connected, it should be thoroughly flushed with air or washed to remove chips, cutting oil and other debris from inside the pipe.

(2) Wrapping of sealant tape

When screwing piping or fittings into ports, ensure that chips from the pipe threads or sealing material do not enter the piping. Also, if sealant tape is used, leave 1 thread ridge exposed at the end of the threads.

(3) Before mounting, confirm the model, size, etc.

Also, confirm that there are no scratches, dents or cracks in the product.

(4) When connecting a tubing, consider factors such as changes in the tubing length due to pressure, and allow sufficient leeway.

(5) Make sure that no twisting, turning, tensile force or moment load is applied to the S coupler and pipings.

This may cause damage to the fitting or crushing, bursting or disconnection of tubing.

(6) Mount so that tubing is not damaged by becoming entangled or abrasion.

This can cause crushing, bursting or disconnection of tubing, etc.

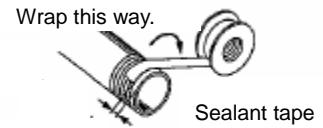

Leave 1 thread exposed.

Air Supply

Warning

(1) When there is a large amount of condensate

Compressed air containing a large amount of condensate can cause the malfunction of pneumatic equipment. An air dryer or water droplet separator should be installed upstream from the filters.

(2) Drain flushing

If condensate in the drain bowl is not emptied on a regular basis, the bowl will overflow and this may cause the malfunction of pneumatic equipment.

If the drain bowl is difficult to check and remove, installation of a drain bowl with an auto drain option is recommended.

For compressed air quality, refer to the SMC catalog "Air Cleaning Systems".

(3) Use clean air.

Do not use compressed air that contains chemicals, synthetic oils including organic solvents, salt or corrosive gases, etc., as it can cause damage or malfunction of equipment.

Caution

(1) Install air filters.

Install an air filter upstream, near the valve. Select an air filter with a filtration size of 5 μ m or smaller.

(2) Take appropriate measures to ensure air quality, such as by providing an aftercooler, air dryer, or water separator.

Compressed air containing a large amount of condensate can cause the malfunction of pneumatic equipment. Take measures to ensure air quality, such as by installing an aftercooler, air dryer, or water separator.

(3) Ensure that the fluid and ambient temperature are within the specified range.

When operating at temperatures below 5°C, moisture in the circuit may freeze and cause breakage of seals or a malfunction. Corrective measures should be taken to prevent freezing.

For detailed information regarding the quality of the compressed air described above, refer to SMC catalog "Air Cleaning Systems".

Operating environment

Warning

- (1) Do not use in an environment where corrosive gases, chemicals, sea water, water or steam are present.
- (2) If using in a location directly exposed to sunlight, shade the product from the sunlight.
- (3) Do not mount the product in locations where it is exposed to radiant heat.
- (4) Do not use the product in a place where static electricity is a problem. It may result in system failure or malfunction. Consult with SMC if using in such an environment.
- (5) Do not use in an environment where the product is directly exposed to cutting oil, lubricant oil or coolant liquid, etc.
Consult with SMC if the product is to be used in an environment where it is directly exposed to cutting oil, lubricant oil or coolant liquid, etc.
- (6) Do not operate in environments subject to heavy vibration and/or impact. Contact SMC when using in this kind of location, as leakage and damage to the fitting can result.
- (7) Do not use the product in a place where spatter can splash or get inside the product. Spatter may cause fire. Consult with SMC if using in such an environment.
- (8) Do not use in an environment where water splashes onto the product frequently.
Rust may be generated easily.
- (9) Do not use the product in a place or environment where foreign matter may get stuck to or get inside the product.
This can cause air leakage or disconnection of the tubing.

Maintenance

Caution

- (1) Maintenance should be performed according to the procedure indicated in the Operation Manual. Improper handling can cause damage and malfunction of equipment and machinery.
- (2) Maintenance work
If handled improperly, compressed air can be dangerous. Assembly, handling, repair and element replacement of pneumatic systems should be performed by a knowledgeable and experienced person.
- (3) Draining
Remove drainage moisture from air filters regularly.
- (4) Removal of equipment, and supply/exhaust of compressed air
When components are removed, first confirm that measures are in place to prevent workpiece from dropping and/or equipment running away, etc. Cut the supply pressure and electric power and exhaust all compressed air from the system. Before restarting the equipment, confirm that measures are taken to prevent sudden action.

- (5) Make sure to wear safety goggles for regular maintenance.
- (6) Please check the following points, and replace the parts as necessary.
 - a) Scratches, damage, wear, or corrosion
 - b) Air leakage
 - c) Squeezing, kinking or twisting of the tubing
 - d) Hardening, deterioration or softening of the tubing
- (7) Do not repair or patch the replaced tubing or coupler for reuse.
- (8) Do not disassemble the product, as it may affect the quality of the product.

Handling

Warning

- (1) When connecting the plug, hold the plug securely.

The plug may be disconnected due to the reaction force of the connection.
- (2) To connect the plug, push it firmly into the socket until it clicks into place.

After connecting the plug, pull it gently to confirm that it will not come out from the socket. If it is not connected firmly, the plug can pop out under pressure. Do not touch the sleeve until it is confirmed that the plug has been inserted firmly. Otherwise, it may cause malfunction.
- (3) The plug should be upright to the socket when connected.

Inclined connection can damage the plug and socket, or cause malfunction.
- (4) When disconnecting the plug, hold the plug securely.

The connected pipings may move due to the reaction force during disconnection or the residual pressure on the plug side.
- (5) The sleeve should be upright to the socket when it is moved.

Rotating in the circumferential direction can cause malfunction.
- (6) Do not push the inside of the socket with a non-compatible plug, or with any type of stick.

Otherwise, the fluid can jet out and cause danger. Also, the seals can pop out along with the jet of fluid, which can break the product.
- (7) If foreign matter adheres to the plug O-ring, wipe it off.

If the air blow is performed with the air gun air outlet close to the plug O-ring, the Plug O-ring may come off.
- (8) If the plug and socket are unable to separate due to a malfunction in the sleeve, do not forcefully pull out the plug. View the sleeve from the insertion side of the plug and turn the sleeve 3-5 turns clockwise. Then, check that the sleeve works properly.

If the sleeve still malfunctions, turn the sleeve counterclockwise for 3 to 5 times.
If the problem is still not solved, loosen the connecting screw for the plug and socket and remove the sleeve from the piping.

(9) Water is an incompressible fluid. The piping design needs to take the fluid characteristics into consideration.

If there is piping with a plug and socket with a check valve that is filled with water, and another valve which is closed while the plug and socket are separated, the pipe from the check valve to the closed valve will also be filled with water. (See the circuit below)

Once the plug and socket are separated in above condition, they cannot be re-connected because the water needs to be compressed.

Circuit Example

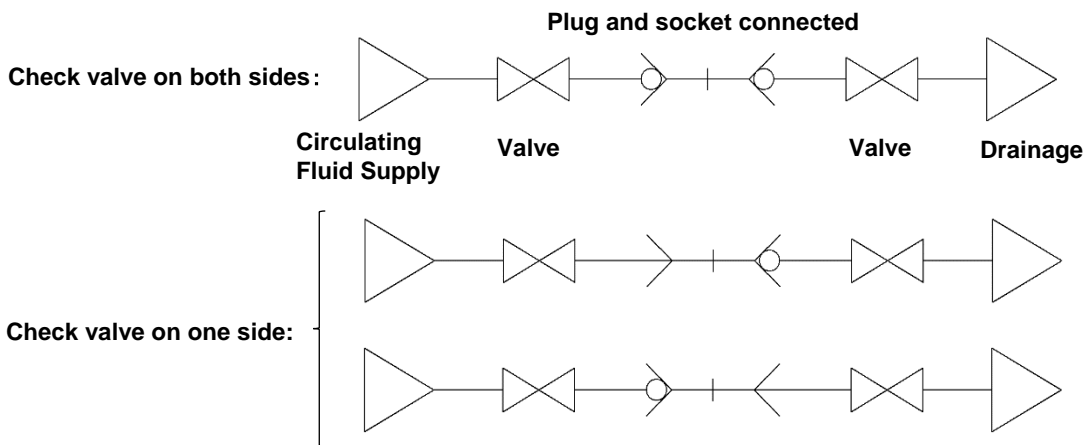

Plug insertion force under pressurized condition

KKA series insertion force

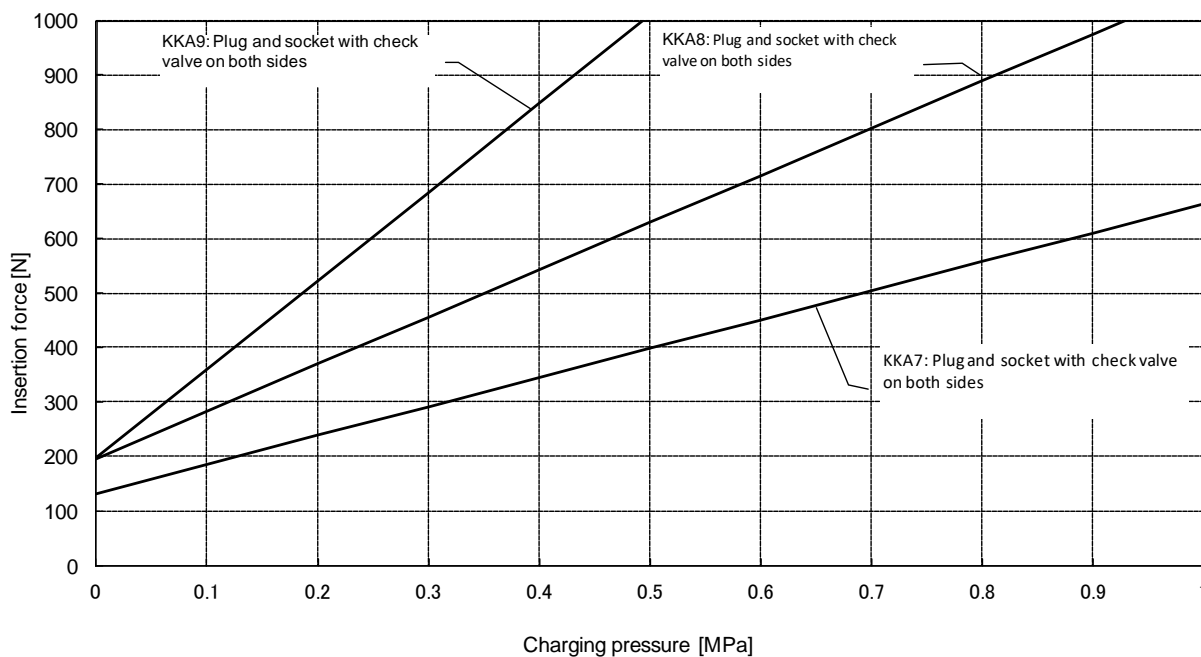
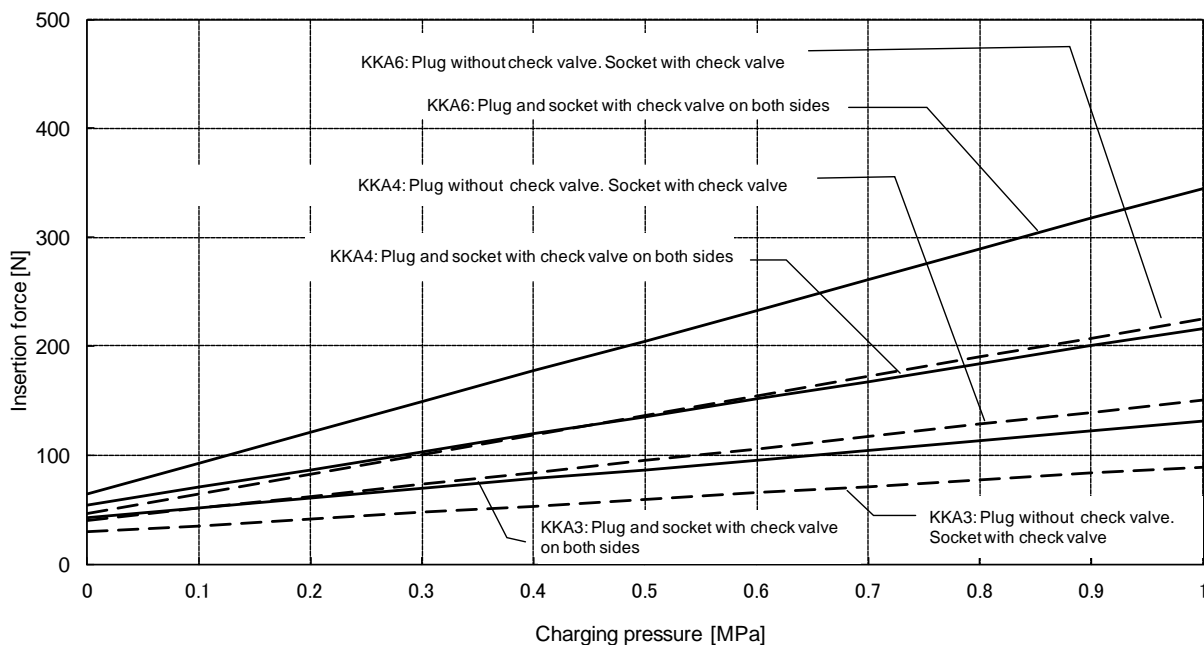

Handling Precautions for screw piping

Caution

(1) Tighten the screws with an appropriate spanner, using the hexagonal face of the S coupler. Position the spanner as close to the thread as possible. Do not apply pliers or pipe wrench to any parts other than the spanner flats. This may cause damage to the product and/or leakage.

(2) Tightening Method

First, tighten the fitting by hand, then use a wrench appropriate for the hexagon flats of the body to tighten it a further two or three turns.

For a tightening torque guide, see the table below.

Thread size	Tightening torque (Nm)
NPT, R1/8	3 to 5
NPT, R1/4	8 to 12
NPT, R3/8	15 to 20
NPT, R1/2	20 to 25
NPT, R3/4	28 to 30
NPT, R1	36 to 38
NPT, R1 1/4	40 to 42
NPT, R1 1/2	48 to 50

(3) If the product is screwed in with excessive torque, a large amount of sealant will seep out. Remove the excess sealant.

(4) Insufficient tightening may cause sealing failure or a loose connection.

(5) Reuse

1) Normally, the fittings with sealant can be reused 2 to 3 times.

2) Remove loose sealant that is stuck to the fitting by blowing air over the threaded portion of the fitting before reusing. If the loose sealant enters adjacent machinery, it may cause air leakage or malfunction.

3) When the sealant loses its sealing effect, re-wrap sealant tape over the thread before using. Use sealant tape only, do not use other types of sealant.

(6) When positioning is required, loosening the piping after it is once tightened may cause air leakage.

2. Specifications

Model No.	KKA3	KKA4 / 6 / 7 / 8 / 9
Fluid	Water, air	
Operating pressure range ^{Note 1}	-100 kPa to 1 MPa	0 to 1 MPa
Proof pressure	10 MPa	
Ambient and fluid temperature	-5 to 150°C (No freezing) NOTE: Do not use the product with steam.	
Non-grease type	No grease used. (Rubber: Fluorine coating, Metallic sliding parts: Fluorine coated)	
Material	SUS304, FKM	
Sealing	Male thread with sealant	

Note 1: The product allows leakage, and should not be used for applications such as holding vacuum in a leak tester.

3. Troubleshooting

In order to maintain product quality, disassembly or repair of the KKA series S coupler is not allowed. Therefore, in cases of failure such as the plug or socket cannot be connected or disconnected; or the fluid does not flow, the whole product needs to be replaced. However, the plug O-ring can be replaced. Refer to "Spare parts" on page 14.

4. Construction

KKA

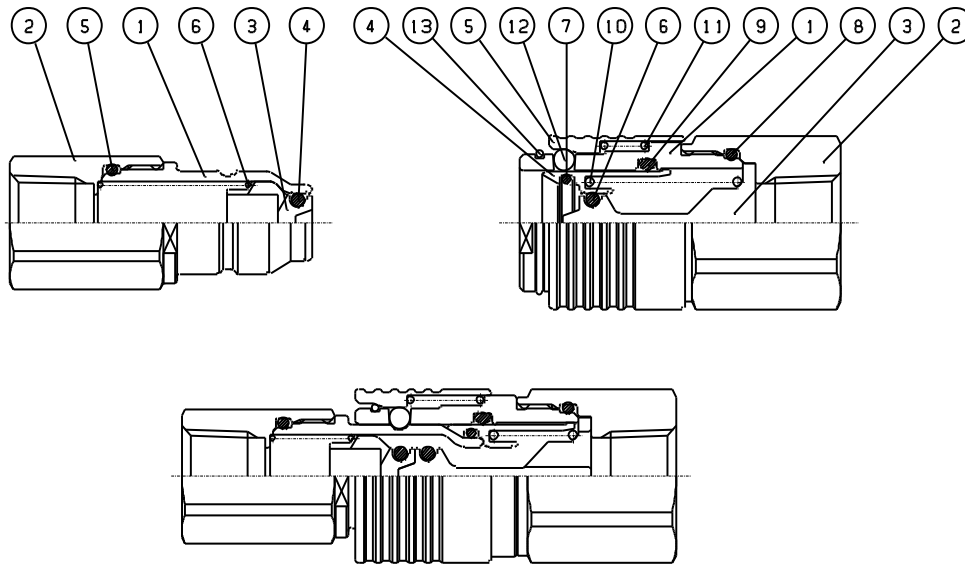

Plug

No.	Description	Material	NOTE
1	Stem	Stainless steel 304	Fluorine coated
2	Rear stem	Stainless steel 304	
3	Plug valve	Stainless steel 304	
4	Valve O-ring	Special FKM	Fluorine coated
5	Stem O-ring	Special FKM	Fluorine coated
6	Plug valve spring	Equivalent to Stainless steel 304	(KKA3)
		Stainless steel 304	(KKA4/6/7/8/9)

Socket

No.	Description	Material	NOTE
1	Body	Stainless steel 304	
2	Rear body	Stainless steel 304	
3	Socket valve	Stainless steel 304	
4	Collar	Stainless steel 304	Fluorine coated
5	Sleeve	Stainless steel 304	Plated with Fluorine-containing material
6	Valve O-ring	Special FKM	Fluorine coated
7	Plug O-ring	Special FKM	Fluorine coated
8	Body O-ring	Special FKM	Fluorine coated
9	Collar seal	Special FKM	Fluorine coated
10	Collar spring	Equivalent to Stainless steel 304	(KKA3/4/6)
		Stainless steel 304	(KKA7/8/9)
11	Sleeve spring	Stainless steel 304	
12	Steel ball	Stainless steel 304	
13	Stopper ring	Stainless steel 304	

5. Spare Parts

Description	Part No.
Plug O-ring	KKA3S-P01
	KKA4S-P01
	KKA6S-P01
	KKA7S-P01
	KKA8S-P01
	KKA9S-P01

Revision history

A :

- Safety Instructions added
- Selection: Warning No. 9 added
- Handling: Warning No.6 added

B :

- Mounting: Warning No.3 changed
- Changed notation of tightening method
- Handling: Warning No.5/8/9 added

SMC Corporation

4-14-1, Sotokanda, Chiyoda-ku, Tokyo 101-0021 JAPAN

Tel: + 81 3 5207 8249 Fax: +81 3 5298 5362

URL <https://www.smcworld.com>

Note: Specifications are subject to change without prior notice and any obligation on the part of the manufacturer.
© 2011 SMC Corporation All Rights Reserved