



Operation Manual

PRODUCT NAME

Coolant valve

MODEL / Series / Product Number

SGC/SGH Series

SMC Corporation

Contents

Safety Instructions -----	2,3
Precautions for Design -----	4
Selection -----	4,5
Mounting -----	5
Piping -----	5
Operating Environment -----	6
Maintenance and Inspection -----	6
Precautions -----	6
Manual Override Operation -----	6
Connecting cable -----	7
Leakage voltage -----	7
Response -----	7
Light/Surge Voltage Suppressor (Pilot valve: V116) -----	8
M12 Connector -----	9
How to Use Conduit terminal (Pilot valve: V116) -----	9
How to Use DIN Terminal (Pilot valve: V116) -----	10
How to Use DIN Terminal (Pilot valve: VO307) -----	11
Light/Surge Voltage Suppressor (Pilot valve: VO307) -----	11
Electrical wiring -----	11
Troubleshooting -----	12



Safety Instructions

These safety instructions are intended to prevent hazardous situations and/or equipment damage. These instructions indicate the level of potential hazard with the labels of "Caution," "Warning" or "Danger." They are all important notes for safety and must be followed in addition to International Standards (ISO/IEC)^{*1)}, and other safety regulations.

*1) ISO 4414: Pneumatic fluid power -- General rules relating to systems.

ISO 4413: Hydraulic fluid power -- General rules relating to systems.

IEC 60204-1: Safety of machinery -- Electrical equipment of machines .(Part 1: General requirements)

ISO 10218-1992: Manipulating industrial robots -Safety.

etc.



Caution

Caution indicates a hazard with a low level of risk which, if not avoided, could result in minor or moderate injury.



Warning

Warning indicates a hazard with a medium level of risk which, if not avoided, could result in death or serious injury.



Danger

Danger indicates a hazard with a high level of risk which, if not avoided, will result in death or serious injury.

Warning

1. The compatibility of the product is the responsibility of the person who designs the equipment or decides its specifications.

Since the product specified here is used under various operating conditions, its compatibility with specific equipment must be decided by the person who designs the equipment or decides its specifications based on necessary analysis and test results.

The expected performance and safety assurance of the equipment will be the responsibility of the person who has determined its compatibility with the product.

This person should also continuously review all specifications of the product referring to its latest catalog information, with a view to giving due consideration to any possibility of equipment failure when configuring the equipment.

2. Only personnel with appropriate training should operate machinery and equipment.

The product specified here may become unsafe if handled incorrectly.

The assembly, operation and maintenance of machines or equipment including our products must be performed by an operator who is appropriately trained and experienced.

3. Do not service or attempt to remove product and machinery/equipment until safety is confirmed.

1. The inspection and maintenance of machinery/equipment should only be performed after measures to prevent falling or runaway of the driven objects have been confirmed.

2. When the product is to be removed, confirm that the safety measures as mentioned above are implemented and the power from any appropriate source is cut, and read and understand the specific product precautions of all relevant products carefully.

3. Before machinery/equipment is restarted, take measures to prevent unexpected operation and malfunction.

4. Contact SMC beforehand and take special consideration of safety measures if the product is to be used in any of the following conditions.

1. Conditions and environments outside of the given specifications, or use outdoors or in a place exposed to direct sunlight.

2. Installation on equipment in conjunction with atomic energy, railways, air navigation, space, shipping, vehicles, military, medical treatment, combustion and recreation, or equipment in contact with food and beverages, emergency stop circuits, clutch and brake circuits in press applications, safety equipment or other applications unsuitable for the standard specifications described in the product catalog.

3. An application which could have negative effects on people, property, or animals requiring special safety analysis.

4. Use in an interlock circuit, which requires the provision of double interlock for possible failure by using a mechanical protective function, and periodical checks to confirm proper operation.



Safety Instructions

Caution

1. The product is provided for use in manufacturing industries.

The product herein described is basically provided for peaceful use in manufacturing industries. If considering using the product in other industries, consult SMC beforehand and exchange specifications or a contract if necessary.
If anything is unclear, contact your nearest sales branch.

Limited warranty and Disclaimer/Compliance Requirements

The product used is subject to the following “Limited warranty and Disclaimer” and “Compliance Requirements”.

Read and accept them before using the product.

Limited warranty and Disclaimer

1. The warranty period of the product is 1 year in service or 1.5 years after the product is delivered, whichever is first.*2)

Also, the product may have specified durability, running distance or replacement parts. Please consult your nearest sales branch.

2. For any failure or damage reported within the warranty period which is clearly our responsibility, a replacement product or necessary parts will be provided.

This limited warranty applies only to our product independently, and not to any other damage incurred due to the failure of the product.

3. Prior to using SMC products, please read and understand the warranty terms and disclaimers noted in the specified catalog for the particular products.

***2) Vacuum pads are excluded from this 1 year warranty.**

A vacuum pad is a consumable part, so it is warranted for a year after it is delivered. Also, even within the warranty period, the wear of a product due to the use of the vacuum pad or failure due to the deterioration of rubber material are not covered by the limited warranty.

Compliance Requirements

1. The use of SMC products with production equipment for the manufacture of weapons of mass destruction (WMD) or any other weapon is strictly prohibited.

2. The exports of SMC products or technology from one country to another are governed by the relevant security laws and regulations of the countries involved in the transaction. Prior to the shipment of a SMC product to another country, assure that all local rules governing that export are known and followed.



SGC / SGH Series Coolant Valve / Precautions 1

Be sure to read this before handling.

Precautions for Design

Warning

1. Cannot be used as an emergency shutoff valve, etc.

The valves presented in this catalogue are not designed for safety applications such as an emergency shutoff valve. If the valves are used in this type of system, other reliable safety assurance measures should also be adopted.

2. This solenoid valve cannot be used for explosion proof applications.

3. Ensure sufficient space for maintenance activities.

When installing the products, allow access for maintenance.

4. Countermeasure against static liquid

In the case of a flowing liquid, provide a bypass valve in the system to maintain continuous fluid flow and prevent pressure increase when the valve is closed.

5. Holding pressure (including vacuum)

Since the valves are subject to air leakage, they cannot be used for applications such as holding pressure (including vacuum) in a pressure vessel.

6. When the conduit type is used as equivalent to an IP65 enclosure, install a wiring conduit, etc.

7. When an impact, such as water hammer, etc., caused by the rapid pressure fluctuation is applied, the solenoid valve may be damaged. Please pay attention to it.

8. Extended periods of continuous energization

If a valve is energized for a long time, the rise in temperature due to heat-up of the coil may cause a decline in solenoid valve performance, reduce service life, or have adverse effects on peripheral equipment. If the total energizing time per day is expected to be longer than the total de-energizing time per day, use a DC specification valve. If AC type is continuously energized for a long period of time, use the air operated valve and continuous duty type pilot valve (VT307).

Selection

Warning

1. Review the specifications.

Give careful consideration to the operating conditions such as the application, fluid and environment, and use within the specified operating ranges in this catalogue.

2. Fluid

Confirm the compatibility with the material.
Please contact SMC if there is any doubt.

3. Fluid quality

The use of a fluid that contains foreign matter can cause problems such as malfunction and seal failure by wearing of the valve body, valve seat and armature, and by sticking to the shaft seal, etc. Install a suitable filter (strainer) immediately upstream from the valve.

As a general rule, use 80 to 100 mesh.

Although the product has a scraper to prevent foreign matter from entering into the product, fluid containing fine foreign matter such as abrasive powder may cause sealing failure by the foreign matter adhering to the rod sliding part.

Selection

Warning

Please perform periodic maintenance or take countermeasures. Sealing failure of the rod sliding surface will allow reverse flow of the fluid in the pilot air piping, entering into the pilot valve or circuit connected to the pilot air piping, causing adverse effects such as operation failure or leakage.

Description	Component No.
Maintenance assembly (See Fig. 1)	SGC(A)□2□□-□□□□ -□□□□-(M)-X400

Note) Maintenance assembly is available only for SGC series. SGH series does not have any maintenance parts. Replace with new product.

Maintenance Procedure

- (1) Loosen four hexagon socket head cap screws on the cover, and then remove them from the body assembly. Make sure to loosen the four head screws evenly a little at a time to avoid galling between the head screws and the threaded parts of the body.
- (2) Remove foreign matter in the body assembly.
- (3) Insert the hexagon socket head cap screws to the maintenance assembly cover, then assemble to the body assembly with the tightening torque in Table 1. According to the head screw tightening procedure shown in Fig. 2, tighten the four screws evenly a little at a time.

Disassembled product is out of the applicable range of product guarantee.

Note) Refer to "Precautions for replacement of the valve".

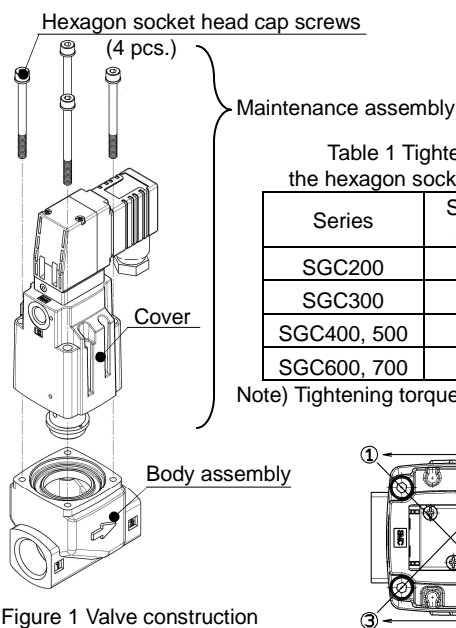

Figure 1 Valve construction

Table 1 Tightening torque of the hexagon socket head cap screw

Series	Screw Size	Tightening Torque
SGC200	M4	1.5N·m
SGC300	M5	3.0N·m
SGC400, 500	M6	5.2N·m
SGC600, 700	M8	12.5N·m

Note) Tightening torque range shall be +/-10%.

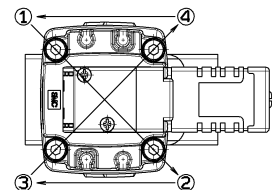

Figure 2 Head screw tightening procedure



SGC / SGH Series Coolant Valve / Precautions 2

Be sure to read this before handling.

Selection

Warning

4. Air quality

1) Use clean air.

Do not use compressed air that contains chemicals, synthetic oils including organic solvents, salt or corrosive gases, etc., as it can cause damage or malfunction.

2) Install air filters.

Install air filters close to valves on the upstream side. A filtration degree of 5 μm or less should be selected.

3) Install an aftercooler or air dryer, etc.

Compressed air that contains excessive drainage may cause malfunction of valves and other pneumatic equipment. To prevent this, install an aftercooler or air dryer, etc.

4) If excessive carbon powder is generated, eliminate it by installing mist separators on the upstream side of valves.

If excessive carbon powder is generated by the compressor, it may adhere to the inside of the valves and cause malfunction.

Refer to SMC's Best Pneumatics catalogue for further details on compressed air quality.

5. Ambient environment

Use within the operable ambient temperature range. Confirm the compatibility between the product's composition materials and the ambient atmosphere. Be certain that the fluid used does not touch the external surface of the product.

6. Countermeasures against static electricity

Take measures to prevent static electricity since some fluids can cause static electricity.

7. Low temperature operation

1) The valve can be used in an ambient temperature down to -5°C. However, take measures to prevent freezing or solidification of impurities, etc.

2) When using valves for water application in cold climates, take appropriate countermeasures to prevent the water from freezing in tubing after cutting the water supply from the pump, by draining the water, etc. When warming by a heater, etc., be careful not to expose the coil portion to a heater. High dew point temperatures coupled with low ambient temperatures, and large flow rates can cause freezing. Please implement measures such as maintaining body temperatures or the installation of air dryers.

Mounting

Warning

1. If air leakage increases or equipment does not operate properly, stop operation.

After mounting is completed, perform a suitable function test to confirm correct mounting.

2. Do not apply external force to the coil section.

When tightening the product, apply a wrench or other tool to the outside of the piping connection parts.

3. Mount a valve with its coil position upwards vertically, not downwards.

If the product is installed vertically downward, foreign matter such as debris in the coolant will accumulate in the plate assembly, shortening the life of the product.

Mounting

Warning

4. Do not warm the coil assembly with a heat insulator, etc.

Use tape, heaters, etc., for freeze prevention on the piping and body only. Heating the coil may burn it out.

5. Secure with brackets, except in the case of steel piping and copper fittings.

6. Avoid sources of vibration, or adjust the arm from the body to the minimum length so that resonance will not occur.

7. Painting and coating

Warnings or specifications printed or labelled on the product should not be erased, removed or covered up.

Piping

Caution

1. Preparation before piping

Before piping is connected, it should be thoroughly blown out with air (flushing) or washed to remove chips, cutting oil and other debris from inside the pipe.

Install piping so that it does not pull, press, bend or apply other forces on the valve body.

2. Wrapping of pipe tape

When screwing piping or fittings into ports, ensure that chips from the pipe threads or sealing material do not enter the piping.

Furthermore, when pipe tape is used, leave 1.5 to 2 thread ridges exposed at the end of the threads.

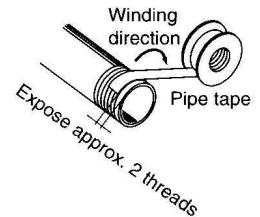

3. Avoid connecting ground lines to piping, as this may cause electric corrosion of the system.

4. Tighten piping with the proper tightening torque.

When attaching piping to valves, tighten with the proper tightening torque shown below.

Tightening Torque for Piping (For coolant valve)

Connection thread	Proper tightening torque (N·m)
Rc1/8	7 to 9
Rc1/4	12 to 14
Rc3/8	22 to 24
Rc1/2	28 to 30
Rc3/4	45 to 50
Rc1	65 to 70
Rc1 1/4	80 to 90
Rc1 1/2	100 to 110
Rc2	140 to 150

5. Connection of piping to products

When connecting piping to a product, refer to its operation manual to avoid mistakes regarding the supply port, etc.



SGC / SGH Series Coolant Valve / Precautions 3

Be sure to read this before handling.

Operating Environment

⚠ Warning

1. Do not use in an atmosphere having corrosive gases, chemicals, sea water, water, steam, or where there is direct contact with any of these .
2. Do not use in explosive atmospheres.
3. Do not use in locations subject to vibration or impact.
4. Do not use in locations where radiated heat will be received from nearby heat sources.
5. Employ suitable protective measures in locations where there is contact with water droplets, oil or welding spatter, etc.
6. If the product is used in an environment where condensation is generated, there may be a risk of rusting.

Maintenance and Inspection

⚠ Warning

1. Removal of product

Valve temperature is high. Confirm that the valve temperature has dropped sufficiently before removing the product. If touched, there is a danger of being burnt.

- 1) Shut off the fluid supply and release the fluid pressure in the system.
- 2) Shut off the power supply.
- 3) Dismount the product.

2. Low frequency operation

Switch valves at least once every 30 days to prevent malfunction. Also conduct a regular inspection once every 6 months, in order to use it under the optimum conditions.

⚠ Caution

1. Filters and strainers

1. Be careful with clogging of filters and strainers.
2. Replace filter elements after a year of use, or earlier if the pressure drop reaches 0.1 MPa.
3. Clean strainers when the pressure drop reaches 0.1 MPa.

2. Lubrication

When using after lubricating, remember to lubricate continuously.

3. Storage

In case of long term storage after use with heated water, thoroughly remove all moisture to prevent rust and deterioration of rubber materials, etc.

4. Exhaust the drainage from an air filter periodically.

Precautions

⚠ Warning

1. Valve temperature is high.

Use caution, as there is a danger of being burnt if a valve is touched directly.

2. When problems are caused by water hammer, install water hammer relief equipment (accumulator, etc.). For details, please contact SMC.

Manual Override Operation

⚠ Warning

When the manual override is operated, connected equipment will be actuated. Confirm safety before operating.

■ Non-locking push type

Press in the direction of the arrow.

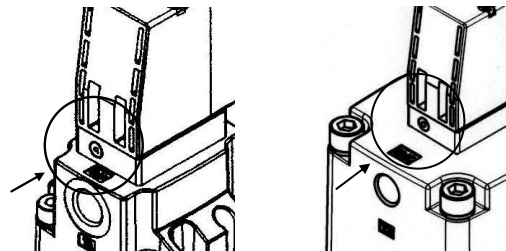

■ Push-turn locking slotted type [D type]

While pressing, turn in the direction of the arrow (90° clockwise). If it is not turned, it can be operated the same way as the non-locking type.

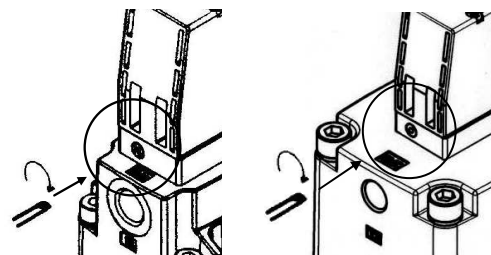

⚠ Caution

When you operate the D type with a screwdriver, turn it gently using a watchmaker's screw driver.

[Tightening torque: Less than 0.1 N·m]

When you lock the manual override of the D type, be sure to push it down before turning. Turning without first pushing it down can cause damage to the manual override and other trouble such as air leakage, etc.



SGC / SGH Series Coolant Valve / Precautions 4

Be sure to read this before handling.

Connecting cable

Caution

1. Applied voltage

When electric power is connected to the solenoid valve, be careful to apply the proper voltage. Improper voltage may cause malfunction or coil damage and void the warranty. It may burn out the coil or cause operation failure.

2. Check the connections.

Check if the connections are correct after completing all wiring.

Leakage voltage

Caution

When a resistor and a switching element are used in parallel or C-R device (surge voltage suppressor) is used for the protection of the switching device, note that leakage voltage will increase because earth leakage current passes through the resistor and C-R device. Keep the leakage voltage as shown below.

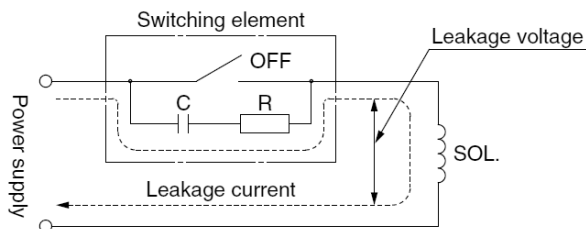

DC coil:

Keep 3% or less of the rated voltage

AC coil:

Pilot valve: V116

Keep 8% or less of the rated voltage

Pilot valve: VO307

Keep 15% or less of the rated voltage

Response

(SGC series)

Caution

Pilot valve V116 is a low power consumption type. The response is slower than VNC series. If the response time is a problem, use products below.

SGC200/300/400: Special request X1(SF4-X240)

SGC500/600/700: Installed pilot valve VO307



SGC / SGH Series Coolant Valve / Precautions 5

Be sure to read this before handling.

Light/Surge Voltage Suppressor

(Pilot Valve: V116)

⚠ Caution

<For DC>

Conduit terminal (Non-polar type)

Surge voltage suppressor (TS)

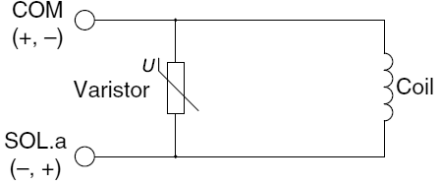

Light/surge voltage suppressor (TZ)

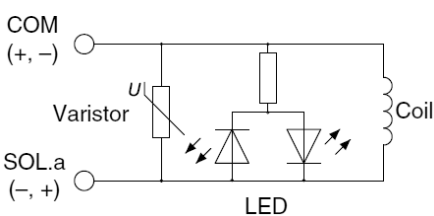

DIN terminal (Non-polar type)

Surge voltage suppressor (DS)

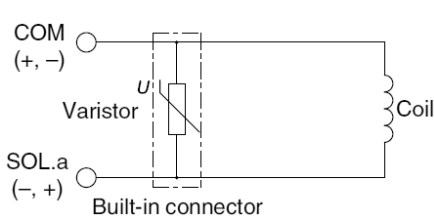

Light/surge voltage suppressor (DZ)

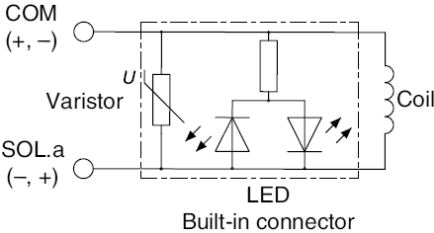

M12 connector type (Non-polar type)

Surge voltage suppressor (WS/VS)

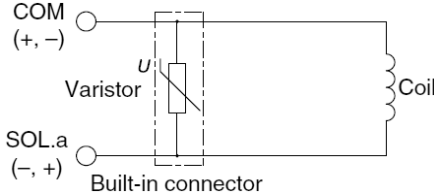

Light/surge voltage suppressor (WZ/VZ)

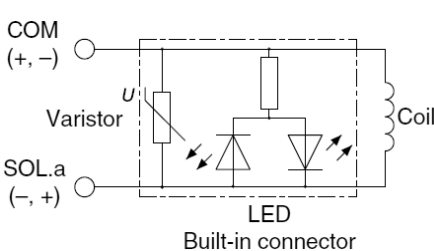

Light/Surge Voltage Suppressor

(Pilot Valve: V116)

⚠ Caution

<For AC>

Conduit terminal

Surge voltage suppressor (TS)

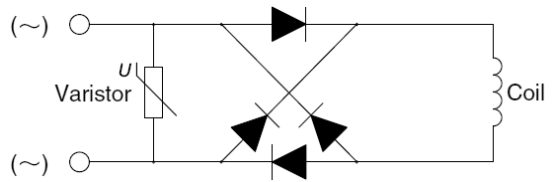

Light/surge voltage suppressor (TZ)

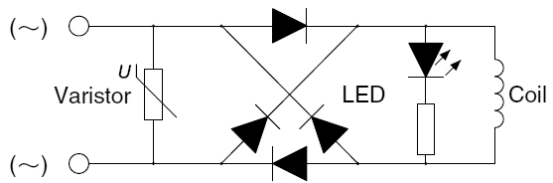

DIN terminal

Surge voltage suppressor (DS)

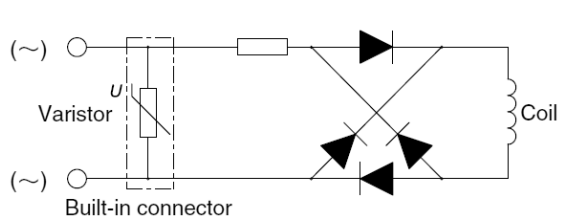

Light/surge voltage suppressor (DZ)

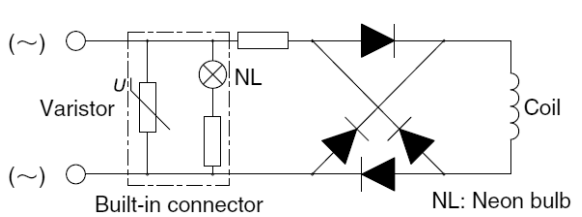

M12 connector type

Surge voltage suppressor (WS/VS)

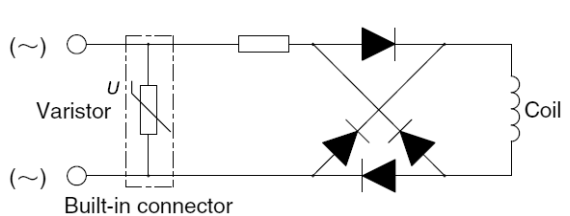

Light/surge voltage suppressor (WZ/VZ)

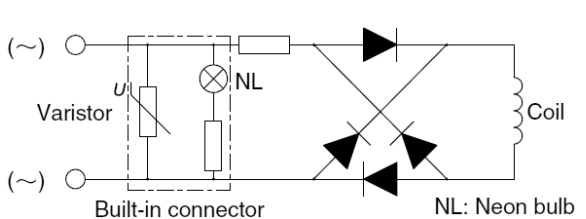



SGC / SGH Series Coolant Valve / Precautions 6

Be sure to read this before handling.

M12 Connector

⚠ Caution

1. M12 connector type of V116 is IP65 compliant. It is protected from dust and water. However, do not use the product under water.
2. Mounting connector using tools may break the connector. Tighten the connector by hand only. (0.4 to 0.6 N·m)
3. IP65 will not be satisfied if excess force is applied to the connector cable. Do not apply force larger than 30N.

If the connector is not tightened adequately, IP65 is not satisfied.

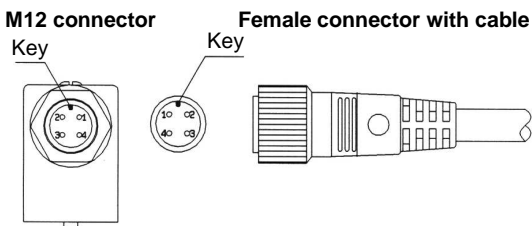

Note) Female connector with cable has orientation. Align the connector key with the M12 connector key of the valve.
If the connector is tightened with force, failure such as the breakage of pin can result.

■ Valve M12 connector pin layout

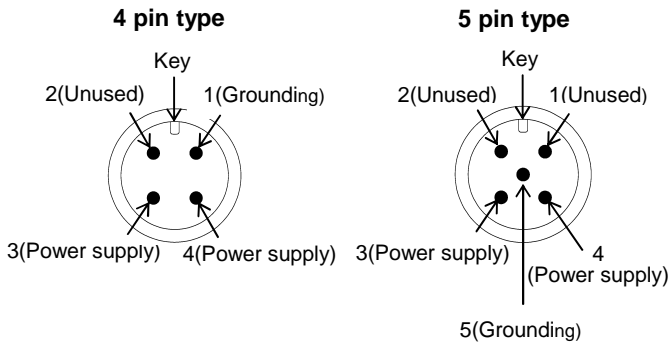

Series	4 pin type		5 pin type	
	DC	AC	DC	AC
SGC	●	●Note)	—	—
SGH	●	●Note)	●	—

Note) AC type is equipped with surge voltage suppressor or light/surge voltage suppressor.

How to Use Conduit terminal

(Pilot Valve: V116)

⚠ Caution

Conduit terminal type is IP65 compliant. It is protected from dust and water. However, do not use the product under water.

Wire connection instructions

- 1) Loosen the mounting screws, then remove the terminal block cover from the terminal block.
- 2) Loosen the terminal block screw and insert the lead wire core or crimp terminal into the terminal and securely fix it with the terminal screw.
- 3) Tighten the ground nut and fix the cord.

If the heavy-duty cord other than specified ($\varnothing 4.5$ to $\varnothing 7$) is used for wiring, IP65 is not satisfied.

Also, be sure to tighten the ground nut and holding screw within their specified torque ranges.

Applicable cable

Cord O.D. $\varnothing 4.5$ to $\varnothing 7$ (Reference) JIS C 3306 equivalent 0.5 to 1.5mm² 2 core or 3 core.

Applicable crimp terminal

O terminal: Product equivalent to R1.25-3 defined by JIS C2805.

Y terminal: Equivalent to 1.25-3Y of Japan Solderless Terminal

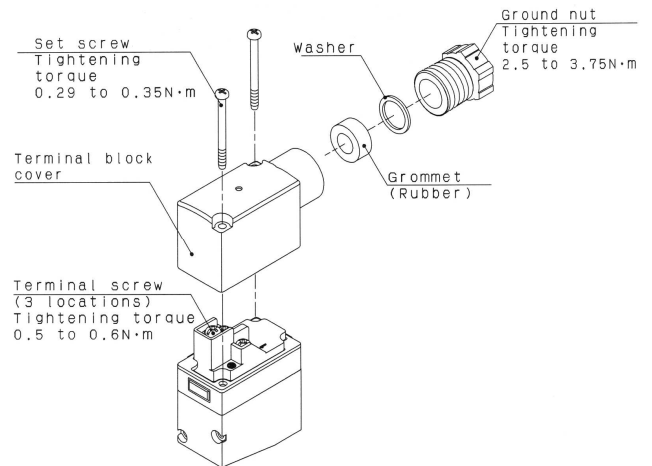



SGC / SGH Series Coolant Valve / Precautions 7

Be sure to read this before handling.

How to Use DIN Terminal

(Pilot Valve: V116)

Caution

DIN terminal type is IP65 compliant. It is protected from dust and water. However, do not use the product under water.

Wire connection instructions

- 1) Loosen the holding screw and pull the connector off of the terminal block of the solenoid valve.
- 2) After removing the holding screw, insert a flat head screw driver into the notch in the lower part of the terminal block to make some clearance and separate the housing from the terminal block.
- 3) Loosen the terminal block screw (slotted head screw), and insert the lead wire core or crimp terminal into the terminal according to the connection procedure and securely fix it with the terminal.
- 4) Tighten the ground nut and fix the cord.

If the heavy-duty cord other than specified ($\varnothing 4.5$ to $\varnothing 7$) is used for wiring, IP65 is not satisfied.

Also, be sure to tighten the ground nut and holding screw within their specified torque ranges.

Changing the entry direction

After separating the terminal block and the housing, the cord entry direction can be changed by attaching the housing at 180 degrees.

*Be careful not to damage the element, etc. with the cord's lead wires.

Caution

- 1) Insert or pull out the connector straight.
- 2) When AC type without DIN terminal connector (DO) is selected, use the DIN connector with surge voltage suppressor.

Exclusive cables

Cord O.D. $\varnothing 4.5$ to $\varnothing 7$ (Reference) JIS C 3306 equivalent 0.5 to 1.5mm^2 2 core or 3 core.

Applicable crimp terminal

O terminal: Up to R1.25-M4 defined by JIS C2805.

Y terminal: Up to 1.25-3Y of Japan Solderless Terminal

Rod terminal: Up to size 1.5

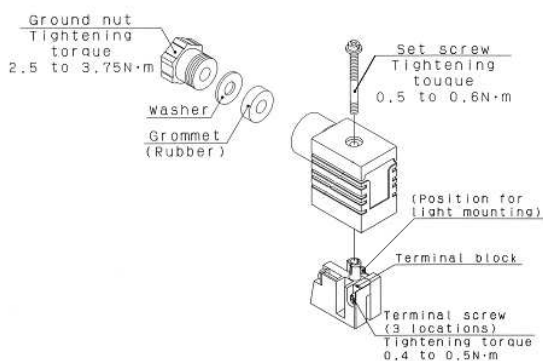



SGC / SGH Series Coolant Valve / Precautions 8

Be sure to read this before handling.

How to Use DIN Terminal

(Pilot Valve: VO307)

⚠ Caution

Disassembly Procedure

- 1) Loosen screw (1) and pull up housing (2) in the direction of screw (1) to remove the connector from the body (solenoid).
- 2) Pull out screw (1) from housing (2).
- 3) On the bottom part of terminal block (3), there is a notch (9). If a small flat head screwdriver is inserted into the gap between housing (2) and terminal block (3), terminal block (3) will be removed from housing (2). (See diagram at the top right of the page.)
- 4) Remove cable gland (4), washer (5) rubber seal (6).

Wiring

- 1) Insert cable gland (4), washer (5) and rubber seal (6) into cable (7) in order, and insert it into housing (2).
- 2) Loosen screws (11) on terminal (3). Insert lead wires (10) and tighten screws (11) again.

Note 1) The tightening torque should be 0.5 N·m +/- 15%.

Note 2) The applicable outside diameter of cable (7) is $\phi 6$ to $\phi 8$ mm.

Note 3) Round or Y-shaped crimped terminal cannot be used.

Reassembly Procedure

- 1) Insert cable gland (4), washer (5) and rubber seal (6) and housing (2) into cable (7) in order. Connect cable (7) to terminal block (3) and fix terminal block (3) to housing (2) in place. Insert the terminal block until it makes a click sound.
 - 2) Insert rubber seal (6) and washer (5) into the cable entry on housing (2) in order, and tighten cable gland (4) securely.
 - 3) Insert gasket (8) into the gap between the bottom of terminal box (3) and plug on the equipment, and insert screw (1) from the top of housing (2) to tighten them.
- Note 1) The tightening torque should be 0.5 N·m +/- 20%.
- Note 2) The orientation of the connector can be changed by 180 degrees depending on the mounting direction of housing (2) and terminal box (3).

DIN terminal connector

Description	Component No.
DIN connector	GM209NJ-B17 (CE compliant product)

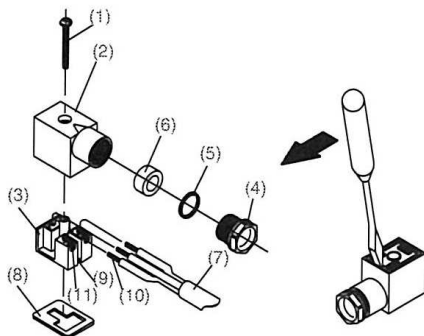

Light/Surge Voltage Suppressor

(Pilot Valve: VO307)

⚠ Caution

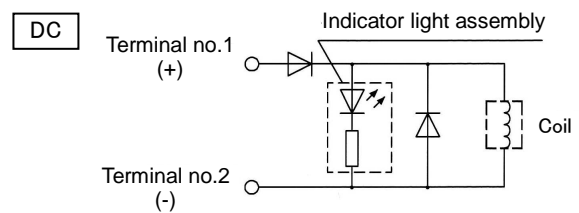
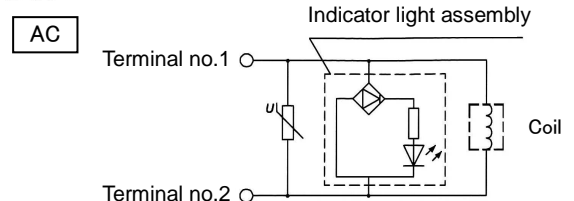

Electrical wiring

(Pilot Valve: VO307)

⚠ Caution

The DIN connector terminal and conduit terminal (with indicator light/surge voltage suppressor) are wired internally as shown below. Connect each terminal to the corresponding wire of the power supply.

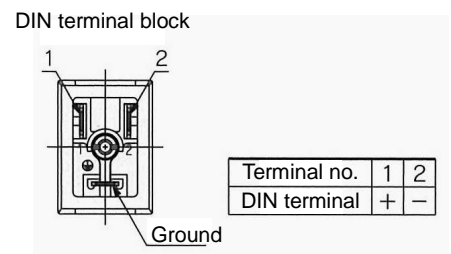

- Applicable cord outside diameter

D type: $\phi 6$ to $\phi 8$ mm

Troubleshooting

⚠ Caution

Troubleshooting

Make sure that the operating voltage, fluid pressure, and environment are within the specification range before starting the equipment.

Check if wires and piping are connected correctly.

The following are possible causes. Take corrective actions referring to these items.

Phenomenon	Cause
The valve does not perform the switching operation when power is supplied. (The pilot valve does not switch)	<ul style="list-style-type: none">- The wiring is not correct.- The connection is not correct.- Fuse is blown.- Wiring is disconnected.- Operating voltage is not within the allowable range.
The pilot valve is operating. Pilot valve operates, but valve does not switch. Switching of the valve is delayed.	<ul style="list-style-type: none">- 1(P), 12 port is not supplied with pressure.- Pressure is not within operating range.
Large amount of coolant leakage to the secondary side (2 port)	<ul style="list-style-type: none">- Inlet (1 port) pressure exceeds the operating pressure range.

If the countermeasures above are not effective, there may be a problem with the valve.
Stop using the valve immediately.

If any of the examples below are applicable, there may be an internal problem with the valve.
Stop using the valve immediately.

- (1) The voltage used was not the rated voltage.
- (2) Severe impact was applied.
- (3) Foreign matter such as condensate or dust entered into the product or a large amount of debris entered the coolant.
- (4) Other than the cases mentioned above, any usage which falls outside the precautions given in this Operation Manual.

Precautions for replacement of the valve

Make sure that the safety measures of equipment and device are taken when the valve is removed from the manifold base.

When any problems are confirmed with the valve, please return the valve as it is.
Do not remove the retaining ring in the cover of NC valve during disassembling for maintenance. Piston or spring will jump out and might cause injury.

Revision history

A	Renewal	oy
B	Safety Instructions	oy
C	Renewal	RP
D	Renewal	RW
E	Renewal	TP
F	Renewal	UX

1st printing: Mo

SMC Corporation

4-14-1, Sotokanda, Chiyoda-ku, Tokyo 101-0021 JAPAN
Tel: + 81 3 5207 8249 Fax: +81 3 5298 5362
URL <http://www.smcworld.com>

Note: Specifications are subject to change without prior notice and any obligation on the part of the manufacturer.
© 2016 SMC Corporation All Rights Reserved