



**MHT2-Z series**  
**Toggle Type Air Gripper. 2 Fingers / Double Acting**

# Improved features and related benefits

**FEATURE:** The new CQ2-Z has been incorporated as the new base cylinder thus improving auto-switch mounting:

- Reduction in number of components
- Fine adjustment of the auto-switch position can be done by just loosening one screw

**CUSTOMER BENEFIT:**

- No loss of components
- Reduction in labour for work
- Reduced assembly and maintenance costs

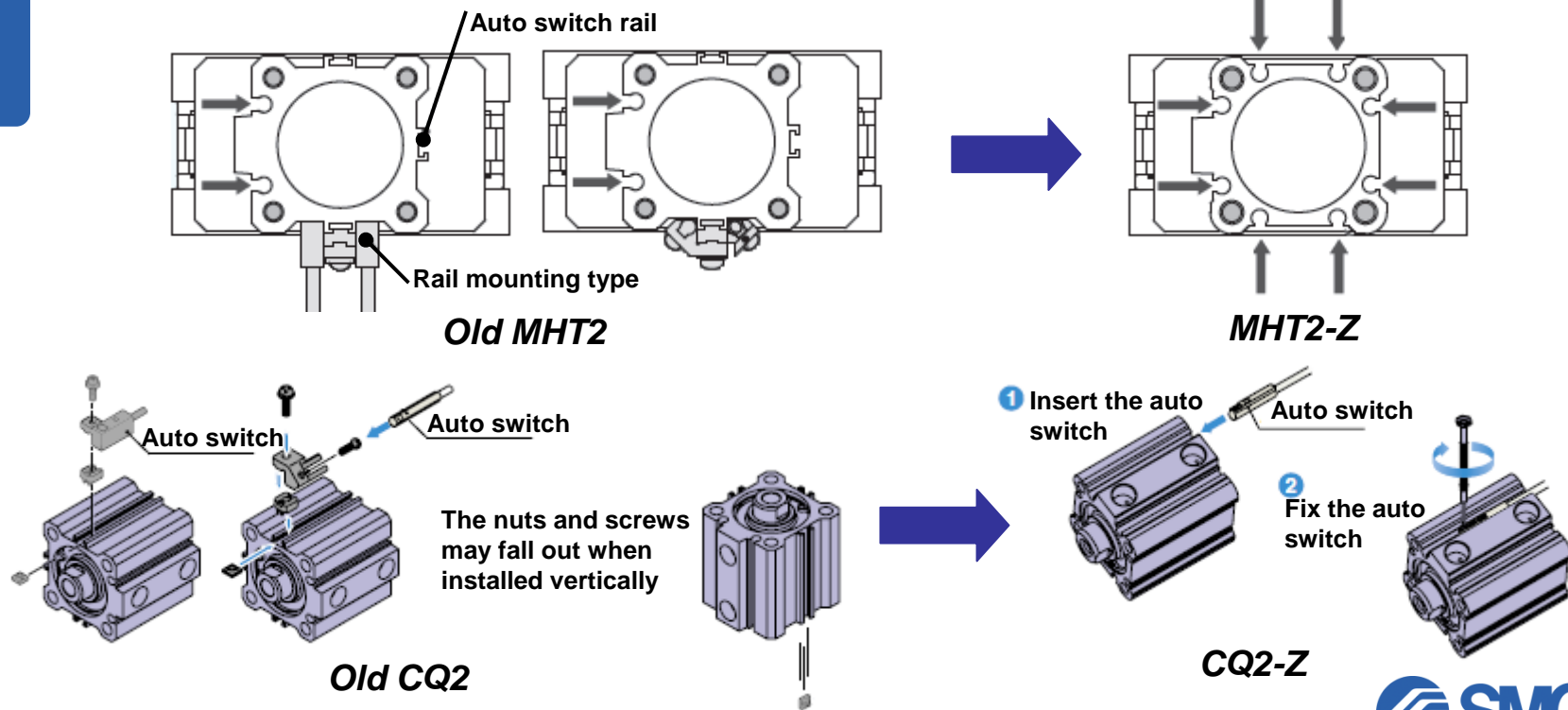

# Improved features and related benefits

**FEATURE:** Weight reduction of up to 80 g by incorporating a new base cylinder

**CUSTOMER BENEFIT:** Cost reduction due to the downsizing of moving parts

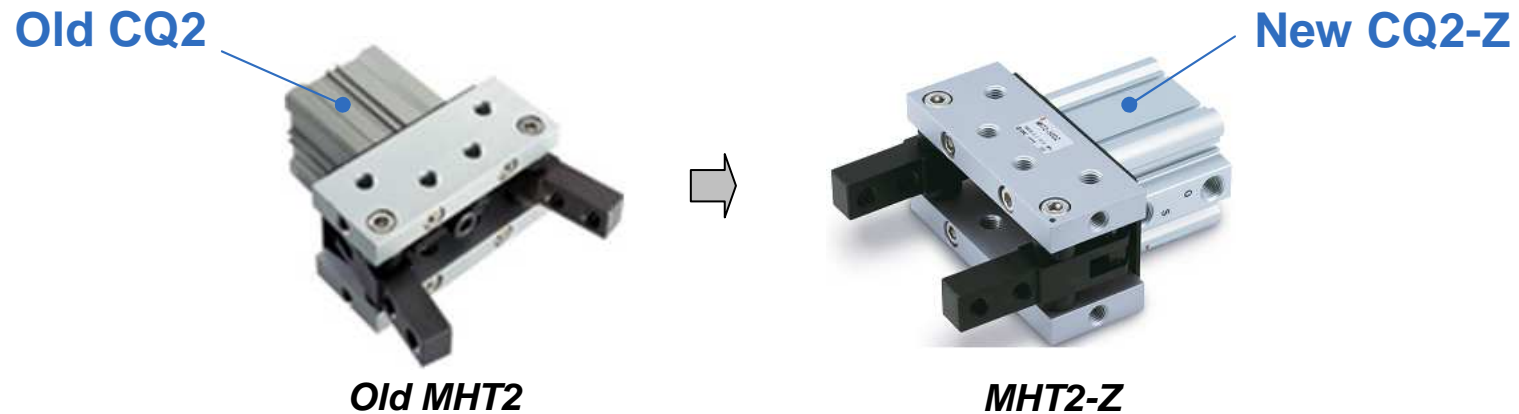

**FEATURE:** Made to orders added:

- Heat resistance: 100 °C (-X4)
- Fluororubber seal (-X5)
- Fluororine grease (-X63)
- Double rod cylinder (-X5060)
- With boss in head side (-X5070)

**CUSTOMER BENEFIT:** Increased flexibility

# Technical details

Differences between MHT2 and MHT2-Z

## ■ Weight changes

Weight		MHT2	MHT2-Z
Model	MHT2-32D(Z)	0.80	0.79
	MHT2-40D(Z)	1.09	1.07
	MHT2-50D(Z)	1.93	1.89
	MHT2-63D(Z)	2.80	2.72

[kg]

## ■ Replacement part changes

Replacement Compact Cylinder		MHT2	MHT2-Z
Model	MHT2-32D(Z)	CDQ2A32-15D	CDQ2A32-15DZ
	MHT2-40D(Z)	CDQ2A40-15D	CDQ2A40-15DZ
	MHT2-50D(Z)	CDQ2A50-20D	CDQ2A50-20DZ
	MHT2-63D(Z)	CDQ2A63-20D	CDQ2A63-20DZ

## ■ Dimensional changes

Dimensions		A [mm]		B [mm]	
		MHT2	MHT2-Z	MHT2	MHT2-Z
Model	MHT2-32D(Z)	30	30.5	7.5	7.5
	MHT2-40D(Z)	35.5	34.5	8	7.5
	MHT2-50D(Z)	39.5	39.5	10.5	10.5
	MHT2-63D(Z)	40.5	40.5	10.5	10.5

