



SWITCHOVER DOCUMENT

MLGP-Z Series

Compact guide cylinder with lock
Ø20, Ø25, Ø32, Ø40, Ø50, Ø63, Ø80 and Ø100

Improved features and related benefits

Feature

- Weight reduction of up to 17% with a new design of the cylinder body, guide rods, front plate, piston rod, collar and head cover.

Customer Benefit

- Cost reduction due to the downsizing of moving parts.

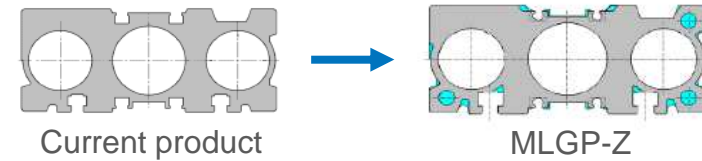

Feature

- Up to 22 mm shorter guide rod protrusion, compared with the current MLGP.

Customer Benefit

- Space saving with same performance.

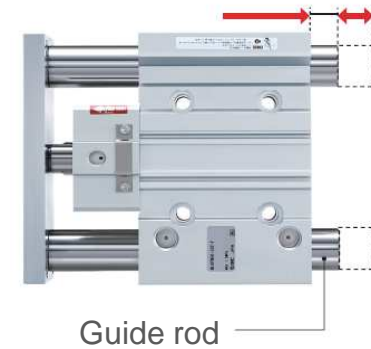

Feature

- The four auto switch mounting grooves are changed from square type to round type for auto switch direct mounting, so compact auto switches or magnetic field-resistant auto switches are allowed to be mounted.

Customer Benefit

- Reduced labour cost for assembly and maintenance and less inventory parts since no brackets are required.



Standard specifications

The specifications and performance are the same as the current product.

Mounting dimensions

Mounting dimensions are the same as the current product.

Applicable auto switches

Auto switch model	MLGP		MLGP-Z	
	Applicability	Mounting bracket	Applicability	Mounting bracket
D-A9*	Ø20-100	BMG2-012	Ø12-100	-
D-Z7*/Z80	Ø20-100	-	-	-
D-M9*	Ø20-100	BMG2-012	Ø12-100	-
D-Y59*/Y69*	Ø20-100	-	-	-
D-Y7*	Ø20-100	-	-	-
D-P3DWA	Ø25-100	BMG2-012	Ø25-100	-
D-P4DW	Ø32-100	-	Ø32-100	BMG7-032